

CAM-M8Q

u-blox M8 Concurrent GNSS Antenna Module Data Sheet

Highlights:

- Concurrent reception of GPS, QZSS, GLONASS and BeiDou
- Industry leading -167 dBm navigation sensitivity
- Embedded wideband and omnidirectional GNSS chip antenna
- Extremely small form factor and low power consumption
- Optional external antenna
- Exceptional jamming immunity
- Form-factor compatible with UC530 and UC530M
- LCC package for reliable and cost effective manufacturing



www.u-blox.com

UBX-13004081 - R04

Document Information

Title	CAM-M8Q		
Subtitle	u-blox M8 Concurrent GNSS Antenna Module		
Document type	Data Sheet		
Document number	UBX-13004081		
Revision and Date	R04	22-May-2014	
Document status	Early Production Information		

Document status explanation

Objective Specification	Document contains target values. Revised and supplementary data will be published later.		
Advance Information	Document contains data based on early testing. Revised and supplementary data will be published later.		
Early Production Information	Document contains data from product verification. Revised and supplementary data may be published later.		
Production Information	Document contains the final product specification.		

This document applies to the following products:

Product name	Type number	ROM/FLASH version	PCN reference
CAM-M8Q	CAM-M8Q-0-00	ROM 2.01	N/A

u-blox reserves all rights to this document and the information contained herein. Products, names, logos and designs described herein may in whole or in part be subject to intellectual property rights. Reproduction, use, modification or disclosure to third parties of this document or any part thereof without the express permission of u-blox is strictly prohibited.

The information contained herein is provided "as is" and u-blox assumes no liability for the use of the information. No warranty, either express or implied, is given, including but not limited, with respect to the accuracy, correctness, reliability and fitness for a particular purpose of the information. This document may be revised by u-blox at any time. For most recent documents, visit www.u-blox.com.

Copyright © 2014, u-blox AG.

u-blox® is a registered trademark of u-blox Holding AG in the EU and other countries. ARM® is the registered trademark of ARM Limited in the EU and other countries.

Contents

Contents.....	3
1 Functional description.....	5
1.1 Overview	5
1.2 Product features.....	5
1.3 GNSS performance.....	6
1.4 Block diagram	7
1.5 GNSS.....	7
1.5.1 GPS	7
1.5.2 GLONASS	7
1.5.3 BeiDou	7
1.5.4 QZSS	8
1.6 Assisted GNSS (A-GNSS)	8
1.6.1 AssistNow™ Online.....	8
1.6.2 AssistNow™ Offline	8
1.6.3 AssistNow™ Autonomous	8
1.7 Augmentation Systems.....	9
1.7.1 Satellite-Based Augmentation System (SBAS)	9
1.7.2 Differential GPS (D-GPS)	9
1.8 Odometer.....	9
1.9 EXTINT: External interrupt	9
1.9.1 Pin Control	9
1.9.2 Aiding	9
1.10 TIMEPULSE	10
1.11 Protocols and interfaces	10
1.12 Interfaces	10
1.12.1 UART.....	10
1.12.2 SPI.....	10
1.12.3 Display Data Channel (DDC).....	10
1.13 Clock generation	11
1.13.1 Oscillators.....	11
1.13.2 Real-Time Clock (RTC)	11
1.14 Power management.....	11
1.14.1 DC/DC converter	11
1.14.2 Operating modes	11
1.15 Antenna.....	12
1.15.1 Embedded Antenna	12
1.15.2 External GPS/GLONASS antenna connectivity	12
1.15.3 Active antenna control (ANTON)	12
1.15.4 Embedded antenna operation.....	12

2	Pin Definition	14
2.1	Pin assignment	14
3	Configuration management	16
3.1	Interface Selection (DSEL)	16
4	Electrical specification	17
4.1	Absolute maximum rating	17
4.2	Operating conditions	18
4.3	Indicative power requirements	18
5	Mechanical specifications	19
6	Reliability tests and approvals	20
6.1	Reliability tests	20
6.2	Approvals	20
7	Product handling & soldering	21
7.1	Packaging	21
7.1.1	Reels	21
7.1.2	Tapes	21
7.2	Shipment, storage and handling	22
7.2.1	Moisture Sensitivity Levels	22
7.2.2	Reflow soldering	22
7.2.3	Antenna ageing	22
7.2.4	ESD handling precautions	22
8	Default messages	23
9	Labeling and ordering information	24
9.1	Product labeling	24
9.2	Explanation of codes	24
9.3	Ordering codes	24
	Related documents	25
	Revision history	25
	Contact	26

1 Functional description

1.1 Overview

The u-blox concurrent CAM-M8Q GNSS chip antenna module has the exceptional performance of the u-blox M8 multi-GNSS (GPS/QZSS, GLONASS and BeiDou) engine in an industry proven form factor. The CAM-M8Q offers high sensitivity and strong signal levels in an ultra-compact form factor.

Incorporating the CAM-M8Q into customer designs is simple and straightforward, thanks to the embedded GNSS chip antenna, a small footprint of 9.6 x 14.0 x 1.95 mm, and sophisticated interference suppression that ensures maximum performance even in GNSS-hostile environments. The low power consumption, and thin design allow end devices to be slimmer and smaller.

Despite of miniature size, the GNSS chip antenna in the CAM-M8Q performs extremely well against traditional patch antennas. The omnidirectional radiation pattern increases flexibility for device installation. Optionally, CAM-M8Q can be connected to an external GNSS antenna. The SMD design keeps manufacturing costs to a minimum and the small mass ensures high reliability.



Because the customer PCB is part of the antenna solution, some PCB layout design rules should be followed in order to maintain optimal performance of the on-board GNSS chip antenna. For more information see the *CAM-M8Q Hardware Integration Manual* [1]

The CAM-M8Q targets industrial and consumer applications that require concurrent GPS and GLONASS or GPS and BeiDou reception. The CAM-M8Q is form-factor compatible to UC530 and UC530M modules, allowing the upgrade of existing designs with minimal effort.

The CAM-M8Q module uses GNSS chips qualified according to AEC-Q100, are manufactured in ISO/TS 16949 certified sites, and fully tested on a system level. Qualification tests are performed as stipulated in the ISO16750 standard: "Road vehicles – Environmental conditions and testing for electrical and electronic equipment". CAM-M8Q complies with green / halogen-free standards.

1.2 Product features

Model	Type	Supply	Interfaces	Features
CAM-M8Q	GPS / QZSS GLONASS Galileo BeiDou Timing Dead Reckoning Precise Point Positioning Raw Data	2.7 V – 3.6 V 3.0 V – 4.2 V Lowest power (DC/DC)	UART USB SPI DDC (I ² C compliant)	Programmable (Flash) Data logger Additional SAW Additional LNA RTC crystal Internal oscillator Active antenna / LNA supply Active antenna / LNA control Antenna short circuit detection / protection pin Antenna open circuit detection pin Timepulse output Frequency output External interrupt / Wakeup
	♦ ♦ ♦	♦ ♦	♦ Sel ♦	♦ ♦ ♦ T ♦ ♦

Sel = Select for either SPI or UART/DDC by HW configuration pin (DSEL)

T = TCXO

1.3 GNSS performance

Parameter	Specification			
Receiver type	72-channel u-blox M8 engine GPS L1C/A SBAS L1C/A QZSS L1C/A GLONASS L1OF BeiDou B1			
		GNSS	GPS & GLONASS	GPS & BeiDou
Time-To-First-Fix ¹	Cold start		26 s	27 s
	Hot start		1 s	1 s
	Aided starts ²		2 s	3 s ³
Sensitivity ⁴	Tracking & Navigation		-167 dBm	-165 dBm
	Reacquisition		-160 dBm	-160 dBm
	Cold start		-148 dBm	-148 dBm
	Hot start		-156 dBm	-156 dBm
		GNSS	GPS & GLONASS	GPS & BeiDou
Max navigation update rate			10 Hz	10 Hz
Velocity accuracy ⁵			0.05 m/s	
Heading accuracy ⁵			0.3 degrees	
Horizontal position accuracy ⁶	Autonomous		2.5 m	
	SBAS		2.0 m	
Accuracy of time pulse signal	RMS		30 ns	
	99%		60 ns	
Frequency of time pulse signal			0.25 Hz... 10 MHz (configurable)	
Operational limits ⁷	Dynamics		≤ 4 g	
	Altitude		50,000 m	
	Velocity		500 m/s	

Table 1: CAM-M8Q performance in different GNSS modes (Default is concurrent reception of GPS and GLONASS)

¹ All satellites at -130 dBm

² Dependent on aiding data connection speed and latency

³ BeiDou assisted acquisitions are not available with ROM 2.01

⁴ Demonstrated with a good external LNA

⁵ 50% @ 30 m/s

⁶ CEP, 50%, 24 hours static, -130 dBm, > 6 SVs

⁷ Assuming Airborne < 4 g platform

1.4 Block diagram

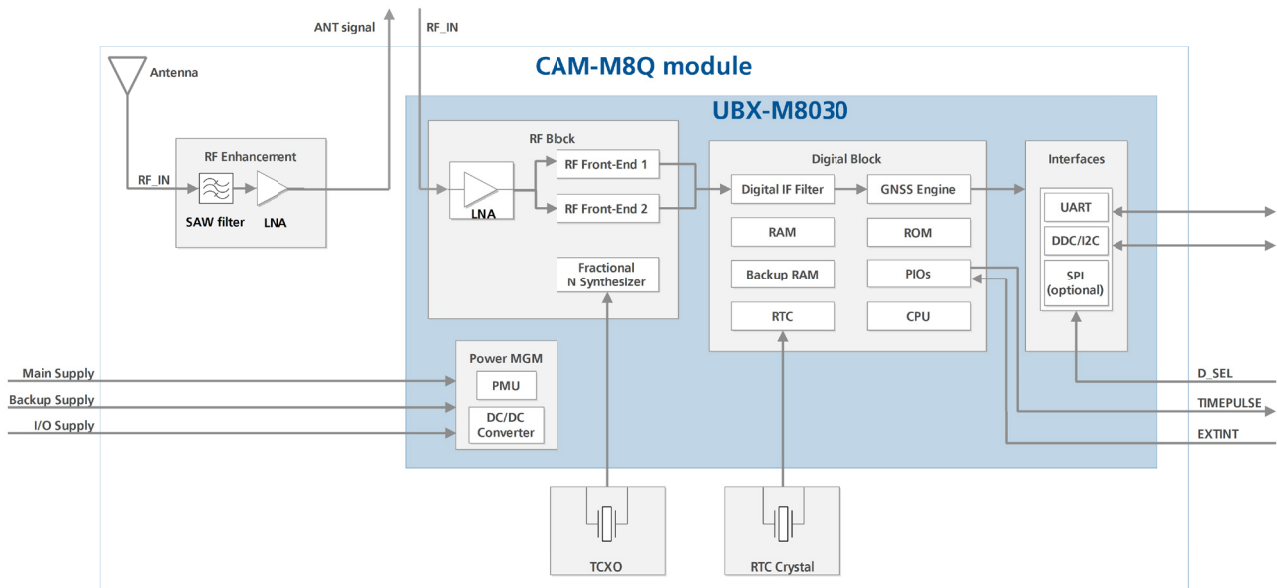

Figure 1: CAM-M8Q block diagram

1.5 GNSS

The CAM-M8Q module is a concurrent GNSS antenna receiver and can receive and track multiple GNSS systems (e.g. GPS, GLONASS, BeiDou and QZSS signals). Because of the dual-frequency RF front-end architecture, two of the three signals (GPS L1C/A, GLONASS L1OF and BeiDou B1) can be received and processed concurrently. By default the CAM-M8Q receiver is configured for concurrent GPS (includes SBAS and QZSS) and GLONASS reception. If power consumption is a key factor, then the receiver should be configured for single GNSS operation using either GPS or GLONASS or BeiDou and disabling QZSS and SBAS.



QZSS and SBAS share the same frequency band as GPS and can always be processed in conjunction with GPS.

1.5.1 GPS

The u-blox CAM-M8Q positioning module is designed to receive and track the L1C/A signals provided at 1575.42 MHz by the Global Positioning System (GPS). GPS can be received and processed concurrently with GLONASS or BeiDou.

1.5.2 GLONASS

The Russian GLONASS satellite system is an alternative system to the US-based Global Positioning System (GPS). The u-blox CAM-M8Q positioning module is designed to receive and track the L1OF signals provided at $1602 \text{ MHz} + k \cdot 562.5 \text{ kHz}$ by GLONASS, where k is the satellite's frequency channel number ($k = -7, -6, \dots, 5, 6$). The ability to receive and track GLONASS L1OF satellite signals allows design of GLONASS receivers where required by regulations. GLONASS can be received and processed concurrently with GPS or BeiDou.

In order to take advantage of GPS and GLONASS, dedicated hardware preparation must be taken during the design-in phase, see the *CAM-M8Q Hardware Integration Manual* [1] for u-blox design recommendations.

1.5.3 BeiDou

The u-blox CAM-M8Q positioning module is designed to receive and track the B1 signals provided at 1561.098 MHz by the BeiDou Navigation Satellite System. The ability to receive and track BeiDou B1 satellite signals in

conjunction with GPS results in higher coverage, improved reliability and better accuracy. BeiDou can be received and processed simultaneously with GPS or GLONASS. By the end of 2013 BeiDou was not fully operational and only provided regional coverage. Global coverage is scheduled for 2020.

1.5.4 QZSS

The Quasi-Zenith Satellite System (QZSS) is a regional navigation satellite system that transmits additional GPS L1C/A signals for the Pacific region covering Japan and Australia. CAM-M8Q concurrent GNSS module is able to receive and track these signals concurrently with GPS, resulting in better availability, especially under bad signal conditions e.g. in urban canyons. Note, that the L1-SAIF signal provided by QZSS is not supported.

1.6 Assisted GNSS (A-GNSS)

Supply of aiding information, such as ephemeris, almanac, rough last position and time, will reduce the time to first fix significantly and improve the acquisition sensitivity. The u-blox CAM-M8Q receiver supports the u-blox AssistNow Online and AssistNow Offline A-GNSS services, support AssistNow Autonomous, and are OMA SUPL compliant.

1.6.1 AssistNow™ Online

With AssistNow Online, an internet-connected GNSS device downloads assistance data from u-blox' AssistNow Online Service at system start-up. AssistNow Online is network operator independent and globally available. u-blox only sends ephemeris data for those satellites currently visible to the device requesting the data, thus minimizing the amount of data transferred.

Supply of aiding information, such as ephemeris, almanac, rough last position and time, will reduce the time to first fix significantly and improve the acquisition sensitivity.

1.6.2 AssistNow™ Offline

With AssistNow Offline, users download u-blox' long-term orbit data from the Internet at their convenience. The orbit data must be stored in the memory of application processor. Therefore, the service requires no connectivity at system start-up and enables a position fix within seconds, even when no network is available. AssistNow Offline data offers augmentation for up to 35 days.

1.6.3 AssistNow™ Autonomous

AssistNow Autonomous provides aiding information without the need for a host or external network connection. It is a free-of-charge embedded feature that accelerates GPS positioning by capitalizing on the periodic nature of GPS satellite orbits (their position in the sky is basically repeated every 24 hours). GPS orbit predictions are directly calculated by the receiver and no external aiding data or connectivity is required. AssistNow Autonomous can be used alone, or together with AssistNow Online or AssistNow Offline for increased positioning speed and accuracy.

u-blox' AssistNow Autonomous benefits are:

- Faster fix in situations where GNSS satellite signals are weak
- No connectivity required
- Compatible with AssistNow Online and Offline services (can work stand-alone, or in tandem with these services)
- No integration effort, calculations are done in the background, transparent to the user.



The u-blox ROM-based CAM-M8Q receiver can use AssistNow Autonomous to calculate GPS-only orbit predictions for up to 6 days (3 days by default). For best AssistNow Autonomous performance, it is recommended to use u-blox M8 flash-based receivers.



For more details see the *u-blox M8 Receiver Description Including Protocol Specification* [2]

1.7 Augmentation Systems

1.7.1 Satellite-Based Augmentation System (SBAS)

The u-blox CAM-M8Q positioning module supports SBAS. These systems supplement GPS data with additional regional or wide area GPS augmentation data. The system broadcasts augmentation data via satellite and this information can be used by GNSS receivers to improve the resulting precision. SBAS satellites can be used as additional satellites for ranging (navigation), further enhancing precision and availability. The following SBAS types are supported with u-blox CAM-M8Q: WAAS, EGNOS and MSAS.



For more details see the *u-blox M8 Receiver Description Including Protocol Specification* [2].

1.7.2 Differential GPS (D-GPS)

The u-blox CAM-M8Q receiver supports Differential-GPS data according RTCM 10402.3: "RECOMMENDED STANDARDS FOR DIFFERENTIAL GNSS". The use of Differential-GPS data improves GPS position accuracy. RTCM cannot be used together with SBAS. The RTCM implementation supports the following RTCM 2.3 messages:

Message Type	Description
1	Differential GPS Corrections
2	Delta Differential GPS Corrections
3	GPS Reference Station Parameters
9	GPS Partial Correction Set

Table 2: Supported RTCM 2.3 messages



For more details see the *u-blox M8 Receiver Description Including Protocol Specification* [2].

1.8 Odometer

The odometer provides information on travelled ground distance (in meters) using solely the position and Doppler-based velocity of the navigation solution. For each computed travelled distance since the last odometer reset, the odometer estimates a 1-sigma accuracy value. The total cumulative ground distance is maintained and saved in the BBR memory.



The odometer feature is disabled by default. For more details see the *u-blox M8 Receiver Description Including Protocol Specification* [2].

1.9 EXTINT: External interrupt

EXTINT is an external interrupt pin with fixed input voltage thresholds with respect to VCC_IO. It can be used for Control of the receiver or for Aiding.

For more information about how to implement and configure these features see the *u-blox M8 Receiver Description including Protocol Specification* [2] and the *CAM-M8Q Hardware Integration Manual* [1].

1.9.1 Pin Control

The pin control feature allows overriding the automatic active/inactive cycle of Power Save Mode. The state of the receiver can be controlled through the EXTINT pin.

The receiver can also be forced OFF using EXTINT when Power Save Mode is not active.

1.9.2 Aiding

The EXTINT pin can be used to supply time or frequency aiding data to the receiver.

For time aiding, hardware time synchronization can be achieved by connecting an accurate time pulse to the EXTINT pin.

Frequency aiding can be implemented by connecting a periodic rectangular signal with a frequency up to 500 kHz and arbitrary duty cycle (low/high phase duration must not be shorter than 50 ns) to the EXTINT pin. Provide the applied frequency value to the receiver using UBX messages.

1.10 TIMEPULSE

A configurable time pulse signal is available with CAM-M8Q module.

The TIMEPULSE output generates pulse trains synchronized with GPS or UTC time grid with intervals configurable over a wide frequency range. Thus it may be used as a low frequency time synchronization pulse or as a high frequency reference signal.

By default the time pulse signal is configured to 1 pulse per second. For more information see the *u-blox M8 Receiver Description including Protocol Specification* [2].

1.11 Protocols and interfaces

Protocol	Type
NMEA	Input/output, ASCII, 0183, version 4.0 (Configurable to 2.3 or 4.1)
UBX	Input/output, binary, u-blox proprietary
RTCM	Input, message 1, 2, 3, 9

Table 3: Available Protocols

All protocols are available on UART, DDC (I²C compliant) and SPI. For specification of the various protocols see the *u-blox M8 Receiver Description Including Protocol Specification* [2].

1.12 Interfaces

A number of interfaces are provided either for data communication or memory access. The embedded firmware uses these interfaces according to their respective protocol specifications.

1.12.1 UART

The CAM-M8Q module supports 1 UART interfaces, which can be used for communication to a host. It supports configurable baud rates. For supported baud rates see the *u-blox M8 Receiver Description Including Protocol Specification* [2].

1.12.2 SPI

The SPI interface is designed to allow communication to a host CPU. The interface can be operated in slave mode only. The maximum transfer rate using SPI is 1 Mb/s and the maximum SPI clock frequency is 5.5 MHz.



SPI is not available in the default configuration, because its pins are shared with the UART and DDC interfaces. The SPI interface can be enabled by connecting DSEL (Pin 20) to ground (see section 3.1).

1.12.3 Display Data Channel (DDC)

An I²C compliant DDC interface is available for communication with an external host CPU. The interface can be operated in slave mode only. The DDC protocol and electrical interface are fully compatible with the Fast-Mode of the I²C industry standard. Since the maximum SCL clock frequency is 400 kHz, the maximum transfer rate is 400 kb/s.

The DDC interface is I²C Fast Mode compliant. For timing parameters consult the I²C standard.



The maximum bit rate is 400 kb/s. The interface stretches the clock when slowed down while serving interrupts, so real bit rates may be slightly lower.

1.13 Clock generation

1.13.1 Oscillators

The CAM-M8Q concurrent GNSS module is available in TCXO version. TCXO option allows accelerated weak signal acquisition, enabling faster start and reacquisition times.

1.13.2 Real-Time Clock (RTC)

The RTC is driven by a 32 kHz oscillator, which makes use of an external RTC crystal. If the main supply voltage fails and a battery is connected to V_BCKP, parts of the receiver switch off, but the RTC still runs providing a timing reference for the receiver. This operating mode is called Hardware Backup Mode, which enables all relevant data to be saved in the backup RAM to allow a hot or warm start later.

The current time is maintained in the RTC and ephemeris and other last known data is kept in the backup RAM. In A-GNSS based systems, the RTC is not required when coarse or fine time information is available from the network.

1.14 Power management

The u-blox CAM-M8Q technology offers a power optimized architecture with built-in autonomous power saving functions to minimize power consumption at any given time. Furthermore, the receiver can be used in two operating modes: Continuous mode for best performance or Power Save Mode for optimized power consumption respectively.

1.14.1 DC/DC converter

The CAM-M8Q module integrates a DC/DC converter, allowing reduced power consumption especially when using a main supply voltage above 2.5 V.



For more information see the *CAM-M8Q Hardware Integration Manual* [1].

1.14.2 Operating modes

The CAM-M8Q module has two operating modes:

- Continuous Mode for best GNSS performance
- Power Save Mode to optimize power consumption

1.14.2.1 Continuous Mode

Continuous Mode uses the acquisition engine at full performance resulting in the shortest possible TTFF and the highest sensitivity. It searches for all possible satellites until the almanac is completely downloaded. The receiver then switches to the tracking engine to lower power consumption.

Thus, a lower tracking current consumption level will be achieved when:

- A valid GNSS position is obtained
- The entire almanac has been downloaded
- The ephemeris for each satellite in view is valid

1.14.2.2 Power Save Mode

For power sensitive applications, u-blox CAM-M8Q receivers provide a Power Save Mode for reduced power consumption.

Power Save Mode uses two dedicated operations called ON/OFF and Cyclic tracking, that reduce average current consumption in different ways to match the needs of the specific application. These operations can be set by using a specific ubx message.



For more information about power management strategies, see the *u-blox M8 Receiver Description Including Protocol Specification* [2].

 Power Save Mode is only available in GPS mode.

1.15 Antenna

The CAM-M8Q concurrent GNSS module is designed with integrated GNSS chip antenna. Optionally, CAM-M8Q can be connected to an external GNSS antenna.

 Because the customer PCB is used as a part of antenna, some important PCB layout design rules should be followed in order to maintain good performance of the on-board GNSS chip antenna. For more information see the *CAM-M8Q Hardware Integration Manual* [1].

1.15.1 Embedded Antenna

The CAM-M8Q module has an embedded GNSS antenna and the signal is further filtered and amplified by internal Low Noise Amplifier (LNA), which is available at ANT output. The antenna signal ANT shall be connected externally to RF_IN Antenna Input signal via a short trace between pads. For more information see the *CAM-M8Q Hardware Integration Manual* [1].

1.15.2 External GPS/GLONASS antenna connectivity

The customer may use an external active GNSS antenna connected via an external RF-switch. It is suggested that the active antenna has a net gain including cable loss in the range from +10 dB to +30 dB. Specified sensitivity is measured with external low noise ($NF \leq 1\text{dB}$, $G \geq 15\text{dB}$) amplifier. The antenna shall provide simultaneous reception of both GPS 1575 MHz and GLONASS bands 1598 to 1606 MHz.

 External passive antenna is not recommended. For more information concerning external antenna option, see the *CAM-M8Q Hardware Integration Manual* [1].

1.15.3 Active antenna control (ANTON)

The ANTON Pin can be used to turn on and off an external LNA or an active antenna. This reduces power consumption in Power Save Mode (Backup mode).

 When ANTON Pin is used externally, an external pull down resistor should be connected at ANTON signal. For more information see the *CAM-M8Q Hardware Integration Manual* [1]

1.15.4 Embedded antenna operation

The embedded GNSS chip antenna provides optimal radiation efficiency 80% typ. with 80x40 mm ground plane. The GNSS chip antenna provides linear polarization with peak gain 1.1 dBi and radiation pattern optimized for portable devices. The chip antenna is insensitive to surroundings and has high tolerance against frequency shifts. Figure 2 shows the typical free space radiation patterns of the embedded GNSS chip antenna at 1575 GHz. However, on small ground plane widths, the antenna gain and radiation efficiency is reduced.

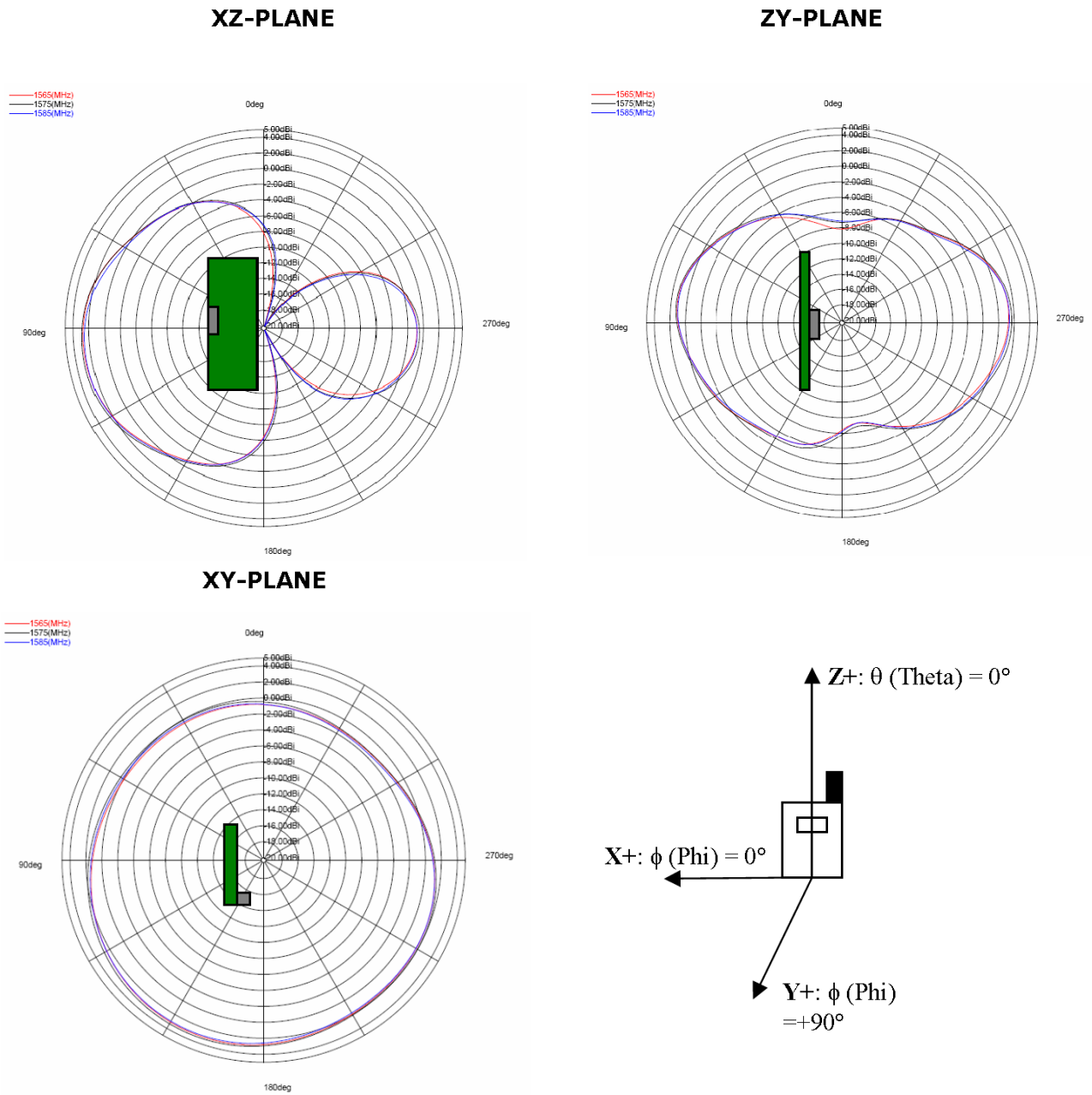

Figure 2: 1.575 GHz typical free space radiation patterns

2 Pin Definition

2.1 Pin assignment

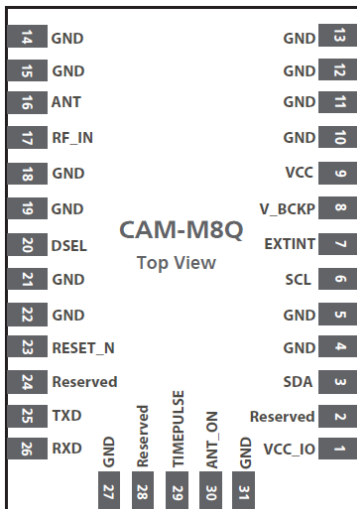

Figure 3: Pin Assignment of CAM-M8Q

No	Name	I/O	Description
1	VCC_IO		IO Supply Voltage
2	Reserved		Reserved
3	SDA SPI CS_N	I/O	DDC Data if D_SEL =1 (or open) SPI Chip Select if D_SEL = 0
4	GND		Ground
5	GND		Ground
6	SCL SPI CLK	I/O	DDC Clock if D_SEL =1(or open) SPI Clock if D_SEL = 0
7	EXTINT		External Interrupt Pin
8	V_BCKP		Backup voltage supply
9	VCC		Supply voltage
10	GND		Ground
11	GND		Ground
12	GND		Ground
13	GND		Ground
14	GND		Ground
15	GND		Ground
16	ANT		Embedded Antenna Output (50 ohm)
17	RF_IN		GPS/GNSS signal input
18	GND		Ground
19	GND		Ground
20	DSEL		Interface select
21	GND		Ground
22	GND		Ground
23	RESET_N		RESET_N

No	Name	I/O	Description
24	Reserved		Reserved for future usage, leave floating
25	TXD SPI MISO	O	Serial Port if D_SEL =1(or open) SPI MISO if D_SEL = 0
26	RXD SPI MOSI	I	Serial Port if D_SEL =1(or open) SPI MOSI if D_SEL = 0
27	GND		Ground
28	Reserved		Reserved
29	TIMEPULSE	O	Time pulse (1 PPS)
30	ANT_ON		Antenna control
31	GND		Ground

Table 4: Pinout for CAM-M8Q

Pins designated Reserved should not be used. For more information about Pinouts see the *CAM-M8Q Hardware Integration Manual* [1].

3 Configuration management

Configuration settings can be modified with UBX configuration messages. The modified settings remain effective until power-down or reset. If these settings have been stored in battery-backup RAM, then the modified configuration will be retained, as long as the backup battery supply is not interrupted.



For more information about configuration management, see the *u-blox M8 Receiver Description including Protocol Specification* [2].

3.1 Interface Selection (DSEL)

At startup, Pin 20 (DSEL) determines which data interfaces are used for communication. If DSEL is set high or left open, UART and DDC become available. If DSEL is set low, i.e. connected to ground, the CAM-M8Q module can communicate to a host via SPI.

PIN #	DSEL = "1" (left open)	DSEL = "0" (connected to GND)
25	TXD	SPI MISO
26	RXD	SPI MOSI
6	SCL	SPI CLK
3	SDA	SPI CS_N

Table 5: Data interface selection by DSEL

4 Electrical specification



The limiting values given are in accordance with the Absolute Maximum Rating System (IEC 134). Stress above one or more of the limiting values may cause permanent damage to the device. These are stress ratings only, and operation of the device at these or at any other conditions above those given in the Characteristics sections of the specification is not implied. Exposure to these limits for extended periods may affect device reliability.



Where application information is given, it is advisory only and does not form part of the specification. For more information see the *CAM-M8Q Hardware Integration Manual* [1].

4.1 Absolute maximum rating

Parameter	Symbol	Condition	Min	Max	Units
Power supply voltage	VCC, VCC_IO		-0.5	3.6	V
Backup battery voltage	V_BCKP		-0.5	3.6	V
Input pin voltage	V _{in}		-0.5	3.6	V
DC current through any digital I/O pin (except supplies)	I _{pin}			10	mA
Input power at RF_IN	P _{rfin}	source impedance = 50 Ω, continuous wave		15	dBm
Storage temperature	T _{stg}		-40	85	°C

Table 6: Absolute maximum ratings of CAM-M8Q



Stressing the device beyond the “Absolute Maximum Ratings” may cause permanent damage. These are stress ratings only. The product is not protected against overvoltage or reversed voltages. If necessary, voltage spikes exceeding the power supply voltage specification, given in table above, must be limited to values within the specified boundaries by using appropriate protection diodes.

4.2 Operating conditions



All specifications are at an ambient temperature of 25°C. Extreme operating temperatures can significantly impact specification values. Applications operating near the temperature limits should be tested to ensure the specification.

Parameter	Symbol	Min	Typ	Max	Units	Condition
Power supply voltage	VCC, VCC_IO	+2.7	+3.0	+3.6	V	
Backup battery voltage	V_BCKP	+1.4		+3.6	V	
Backup battery current	I_BCKP		15		μA	V_BCKP = 3.0 V VCC = 0 V
SW backup current	I_SWBCKP		20		μA	VCC_IO = VCC = 3.0 V
Input pin voltage range	V _{in}	0		VCC_IO	V	
Digital IO Pin Low level input voltage	V _{il}	0		0.2*VCC_IO	V	
Digital IO Pin High level input voltage	V _{ih}	0.7 * VCC_IO		VCC_IO	V	
Digital IO Pin Low level output voltage	V _{ol}			0.4	V	I _{ol} = 4 mA
Digital IO Pin High level output voltage	V _{oh}	VCC_IO - 0.4			V	I _{oh} = 4 mA
Receiver Chain Noise Figure	NF _{tot}		3.5 ⁸		dB	
Operating temperature	Topr	-40		+85	°C	

Table 7: Operating conditions



Operation beyond the specified operating conditions can affect device reliability.

4.3 Indicative power requirements

Table 8 lists examples of the total system supply current for a possible application.



The values in Table 8 are provided for customer information only, as an example of typical power requirements. Values are characterized on samples; actual power requirements can vary depending on FW version used, external circuitry, number of SVs tracked, signal strength, type of start as well as time, duration and conditions of test.

Parameter	Symbol	Typ GPS & GLONASS	Typ GPS / QZSS / SBAS	Max	Units
Max. supply current ⁹	I _{ccp}			71	mA
	I _{cc} Acquisition ¹²	31	25		mA
Average supply current ^{10, 11}	I _{cc} Tracking (Continuous mode)	30	23.5		mA
	I _{cc} Tracking (Power Save mode / 1 Hz)	n.a ¹³	7.0		mA

Table 8: Indicative power requirements at 3.0 V



For more information about power requirements, see the *CAM-M8Q Hardware Integration Manual* [1].



For more information on how to noticeably reduce current consumption, see the *Power Management Application Note* [4].

⁸ On GPS band at RF_IN pin

⁹ Use this figure to dimension maximum current capability of power supply. Measurement of this parameter with 1 Hz bandwidth.

¹⁰ Use this figure to determine required battery capacity.

¹¹ Simulated GNSS constellation using power level of -130 dBm. VCC = 3.0 V

¹² Average current from start-up until the first fix.

¹³ Not applicable

5 Mechanical specifications

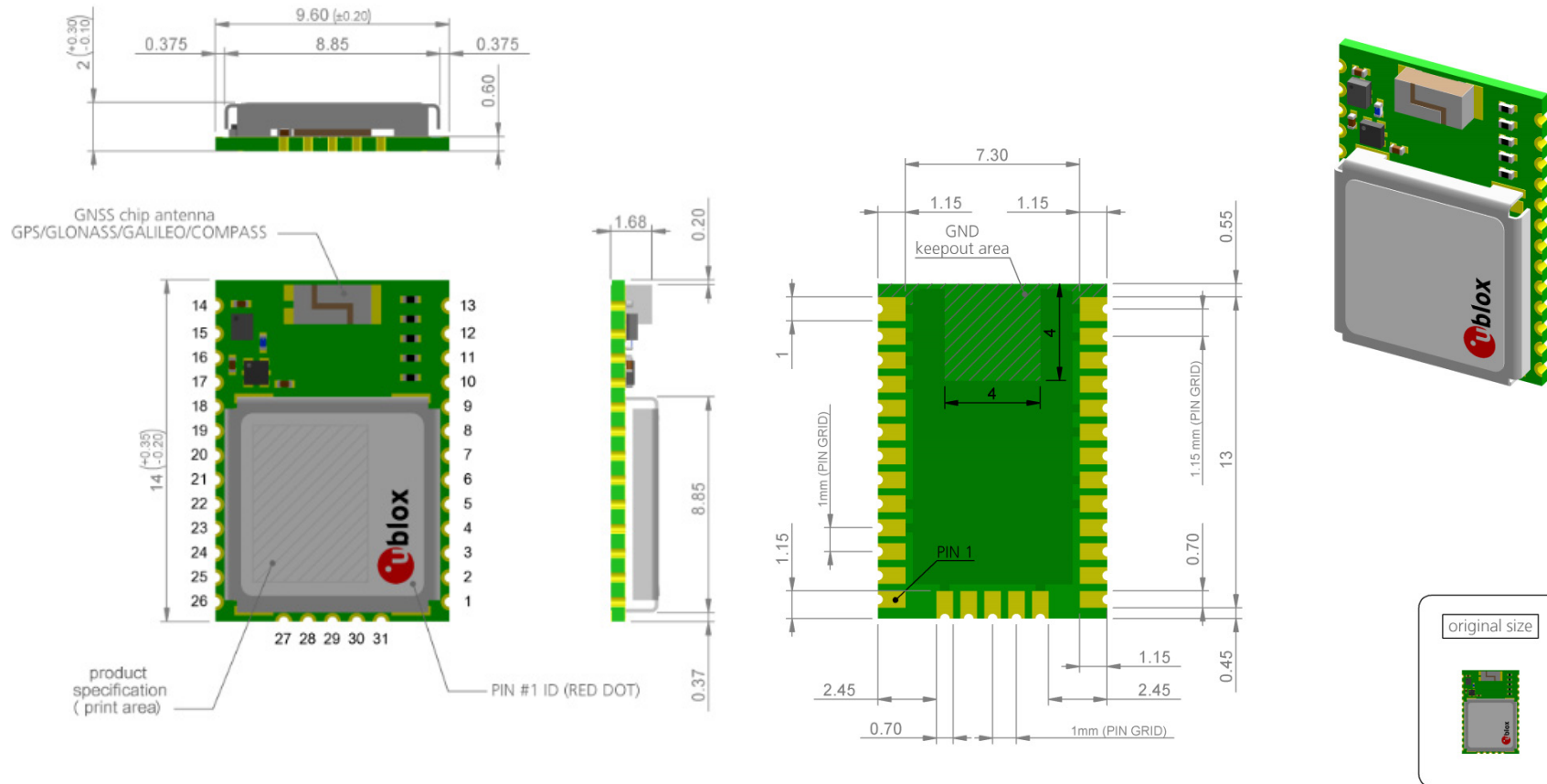

Figure 4: Dimensions (unit: mm)



For information about the paste mask and footprint, see the *CAM-M8Q Hardware Integration Manual* [1].

6 Reliability tests and approvals

6.1 Reliability tests



The CAM-M8Q concurrent GNSS antenna module is based on AEC-Q100 qualified GNSS chips.

Tests for product qualifications are according to ISO 16750 "Road vehicles – Environmental conditions and testing for electrical and electronic equipment", and appropriate standards.

6.2 Approvals



Products marked with this lead-free symbol on the product label comply with the "Directive 2002/95/EC of the European Parliament and the Council on the Restriction of Use of certain Hazardous Substances in Electrical and Electronic Equipment" (RoHS).

u-blox CAM-M8Q concurrent GNSS antenna modules are RoHS compliant.

7 Product handling & soldering

7.1 Packaging

The CAM-M8Q modules are delivered as hermetically sealed, reeled tapes in order to enable efficient production, production lot set-up and tear-down. For more information see the *u-blox Package Information Guide* [3].

7.1.1 Reels

The CAM-M8Q GPS modules are deliverable in quantities of 500 pcs on a reel. The CAM-M8Q modules are shipped on Reel Type B, as specified in the *u-blox Package Information Guide* [3].

7.1.2 Tapes

Figure 5 shows the position and orientation of CAM-M8Q modules as they are delivered on tape. The dimensions of the tape are specified in Figure 6.

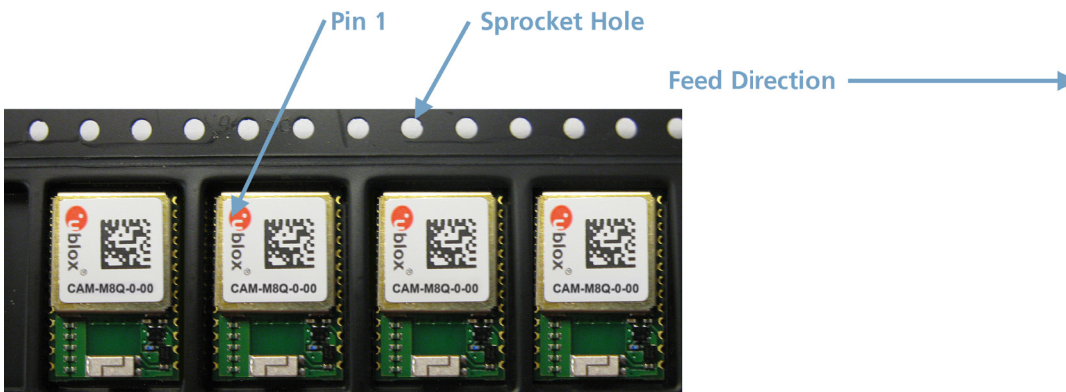

Figure 5: Tape and module orientation

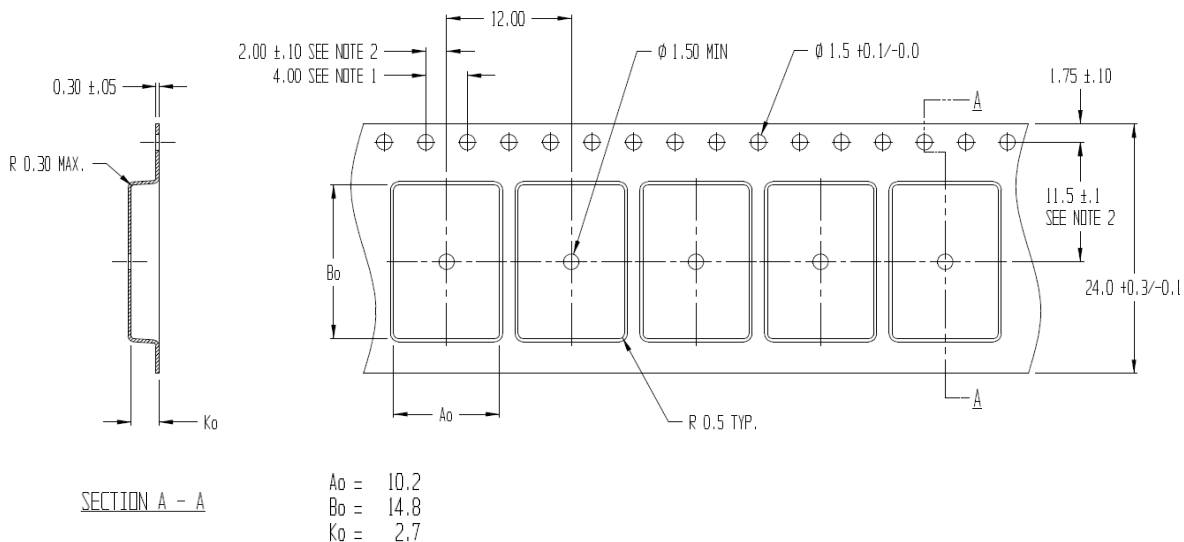

Figure 6: Dimensions and orientation for CAM-M8Q modules on tape

7.2 Shipment, storage and handling

For important information about shipment, storage and handling, see the *u-blox Package Information Guide* [3].

7.2.1 Moisture Sensitivity Levels

The Moisture Sensitivity Level (MSL) relates to the packaging and handling precautions required. CAM-M8Q modules are rated at MSL level 4.



For MSL standard see IPC/JEDEC J-STD-020. Download available at www.jedec.org.



For more information regarding MSL, see the *u-blox Package Information Guide* [3].

7.2.2 Reflow soldering

Reflow profiles are to be selected according u-blox recommendations (see the *CAM-M8Q Hardware Integration Manual* [1]).

7.2.3 Antenna ageing

Antenna electrode metallization is unprotected silver and will tarnish during storage due to sulfuric compounds present in the atmosphere. Elevated temperature and humidity will accelerate this process. Human skin contact, wool etc. will also cause tarnishing. This has no effect on the electrical performance of the antenna. u-blox accepts no warranty claims for tarnished products due to this normal and to be expected process.

7.2.4 ESD handling precautions

 **CAM-M8Q modules are Electrostatic Sensitive Devices (ESD). Observe handling precautions! Failure to observe these precautions can result in severe damage to the GNSS receiver!**

GNSS receivers are Electrostatic Sensitive Devices (ESD) and require special precautions when handling. Exercise care when handling patch antennas, due to the risk of electrostatic charges. In addition to standard ESD safety practices, take the following measures into account whenever handling the receiver:

- Unless there is a galvanic coupling between the local GND (i.e. the work table) and the PCB GND, then the first point of contact when handling the PCB must always be between the local GND and PCB GND.
- Before mounting an antenna patch, connect ground of the device
- When handling the RF pin, do not come into contact with any charged capacitors and be careful when contacting materials that can develop charges (e.g. patch antenna ~10 pF, coax cable ~50-80 pF/m, soldering iron, ...)
- To prevent electrostatic discharge through the RF input, do not touch any exposed antenna area. If there is any risk that such exposed antenna area is touched in non ESD protected work area, implement proper ESD protection measures in the design.
- When soldering RF connectors and patch antennas to the receiver's RF pin, make sure to use an ESD safe soldering iron (tip).



8 Default messages

Interface	Settings
UART Output	9600 Baud, 8 bits, no parity bit, 1 stop bit Configured to transmit both NMEA and UBX protocols, but no UBX messages and only the following NMEA have been activated at start-up: GGA, GLL, GSA, GSV, RMC, TTG, TXT
UART Input	9600 Baud, 8 bits, no parity bit, 1 stop bit, Autobauding disabled Automatically accepts following protocols without need of explicit configuration: UBX, NMEA, RTCM The GPS receiver supports interleaved UBX and NMEA messages.
DDC	Fully compatible with the I ² C industry standard, available for communication with an external host CPU or u-blox cellular modules, operated in slave mode only. NMEA and UBX are enabled as input messages, only NMEA as output messages Maximum bit rate 400 kb/s.
TIMEPULSE (1Hz Nav)	1 pulse per second, synchronized at rising edge, pulse length 100 ms

Table 9: Default messages



Refer to the *u-blox M8 Receiver Description including Protocol Specification* [2] for information about further settings.

9 Labeling and ordering information

9.1 Product labeling

The labeling of u-blox CAM-M8Q GNSS antenna modules includes important product information. The location of the product type number is shown in Figure 7.

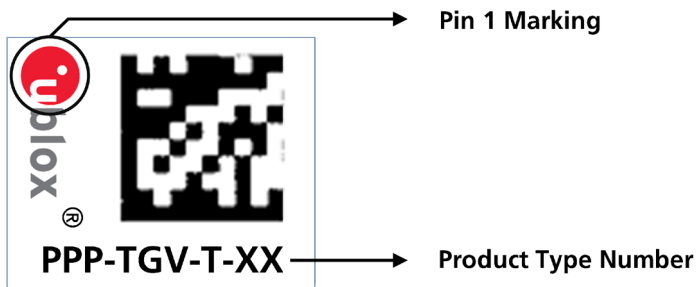

Figure 7: Location of product type number on u-blox CAM-M8Q module label

9.2 Explanation of codes

Three different product code formats are used. The **Product Name** is used in documentation such as this data sheet and identifies all u-blox products, independent of packaging and quality grade. The **Ordering Code** includes options and quality, while the **Type Number** includes the hardware and firmware versions. Table 10 below details these three different formats:

Format	Structure
Product Name	PPP-TGV
Ordering Code	PPP-TGV-T
Type Number	PPP-TGV-T-XX

Table 10: Product code formats

The parts of the product code are explained in Table 11.

Code	Meaning	Example
PPP	Product Family	CAM
TG	Technology & Generation	M8 = u-blox M8
V	Variant	Function set (A-Z), T = Timing, R = DR, etc.
T	Option / Quality Grade	Describes standardized functional element or quality grade 0 = Default variant, A = Automotive
XX	Product Detail	Describes product details or options such as hardware and software revision, cable length, etc.

Table 11: Part identification code

9.3 Ordering codes

Ordering No.	Product
CAM-M8Q-0	u-blox M8 Concurrent GNSS LCC Antenna Module, TCXO, SAW, LNA, ROM, green 9.6 x 14.0 mm, 500 pcs/reel

Table 12: Product ordering codes for standard grade modules



Product changes affecting form, fit or function are documented by u-blox. For a list of Product Change Notifications (PCNs), see our website.

Related documents

- [1] CAM-M8Q Hardware Integration Manual, Docu. No. UBX-14000014
- [2] u-blox M8 Receiver Description including Protocol Specification (Public version), Docu. No. UBX-13003221
- [3] u-blox Package Information Guide, Docu. No. GPS-X-11004
- [4] Power Management Application Note, Docu. No. UBX-13005162



For regular updates to u-blox documentation and to receive product change notifications, register on our homepage.

Revision history

Revision	Date	Name	Status / Comments
R01	05-Feb-2014	julu	Objective Specification
R02	04-Mar-2014	julu	Added VCC_IO specification to Table 6 and Table 7.
R03	14-Mar-2014	julu	Advance Information. Updated Table 1 (added GPS & BeiDou concurrent and GPS only modes) and Table 8 (Indicative power requirements currents); updated product selector table in section 1.2 as alignment; updated section 1.15.2 (passive antenna not recommended). Added SW backup current in Table 7.
R04	22-May-2014	julu	Early Production Information. Added footnote in Table 1 (aided TTFF figure for GPS+BeiDou); updated section 1.15.3. (added instruction for using ANTON Pin externally).

Contact

For complete contact information visit us at www.u-blox.com

u-blox Offices

North, Central and South America

u-blox America, Inc.

Phone: +1 703 483 3180
E-mail: info_us@u-blox.com

Regional Office West Coast:

Phone: +1 408 573 3640
E-mail: info_us@u-blox.com

Technical Support:

Phone: +1 703 483 3185
E-mail: support_us@u-blox.com

Headquarters Europe, Middle East, Africa

u-blox AG

Phone: +41 44 722 74 44
E-mail: info@u-blox.com
Support: support@u-blox.com

Asia, Australia, Pacific

u-blox Singapore Pte. Ltd.

Phone: +65 6734 3811
E-mail: info_ap@u-blox.com
Support: support_ap@u-blox.com

Regional Office Australia:

Phone: +61 2 8448 2016
E-mail: info_anz@u-blox.com
Support: support_ap@u-blox.com

Regional Office China (Beijing):

Phone: +86 10 68 133 545
E-mail: info_cn@u-blox.com
Support: support_cn@u-blox.com

Regional Office China (Shenzhen):

Phone: +86 755 8627 1083
E-mail: info_cn@u-blox.com
Support: support_cn@u-blox.com

Regional Office India:

Phone: +91 959 1302 450
E-mail: info_in@u-blox.com
Support: support_in@u-blox.com

Regional Office Japan:

Phone: +81 3 5775 3850
E-mail: info_jp@u-blox.com
Support: support_jp@u-blox.com

Regional Office Korea:

Phone: +82 2 542 0861
E-mail: info_kr@u-blox.com
Support: support_kr@u-blox.com

Regional Office Taiwan:

Phone: +886 2 2657 1090
E-mail: info_tw@u-blox.com
Support: support_tw@u-blox.com