



PROPRIETARY NOTE

THIS SPECIFICATION IS THE PROPERTY OF BOE OT AND SHALL NOT BE REPRODUCED OR COPIED WITHOUT THE WRITTEN PERMISSION OF BOE OT AND MUST BE RETURNED TO BOE OT UPON ITS REQUEST

TITLE : BP070WS1-500
Product Specification
Rev.0

BEIJING BOE OPTOELECTRONICS TECHNOLOGY

SPEC. NUMBER S1	PRODUCT GROUP TFT-LCD	REV. 0	ISSUE DATE 2013.3.18.	PAGE 1 OF 28
--------------------	--------------------------	-----------	--------------------------	-----------------

Contents

No.	Items	Page
1.0	General Description	4
2.0	Absolute Maximum ratings	6
3.0	Electrical specifications.	7
4.0	Optical specifications.	9
5.0	Interface Connection	13
6.0	Signal Timing Specification	16
7.0	Signal Timing waveforms	18
8.0	Input Signals, Display Colors & Gray Scale of Colors	19
9.0	Power Sequence	20
10.0	Connector description	21
11.0	Mechanical Characteristics	22
12.0	Reliability Test	23
13.0	Handling & Cautions.	23
14.0	Label	24
15.0	Packing information	26
16.0	Mechanical Outline Dimension	27

1.0 GENERAL DESCRIPTION

1.1 Introduction

1.1 Introduction

BP070WS1-500 is a color active matrix TFT LCD module using amorphous silicon TFT's (Thin Film Transistors) as an active switching devices. This module has a 7.0inch diagonally measured active area with WSVGA resolutions (**1024** horizontal by **600** vertical pixel array). Each pixel is divided into RED, GREEN, BLUE dots which are arranged in vertical stripe and this module can display 16.7M colors. The TFT-LCD panel used for this module is adapted for a low reflection and higher color type.

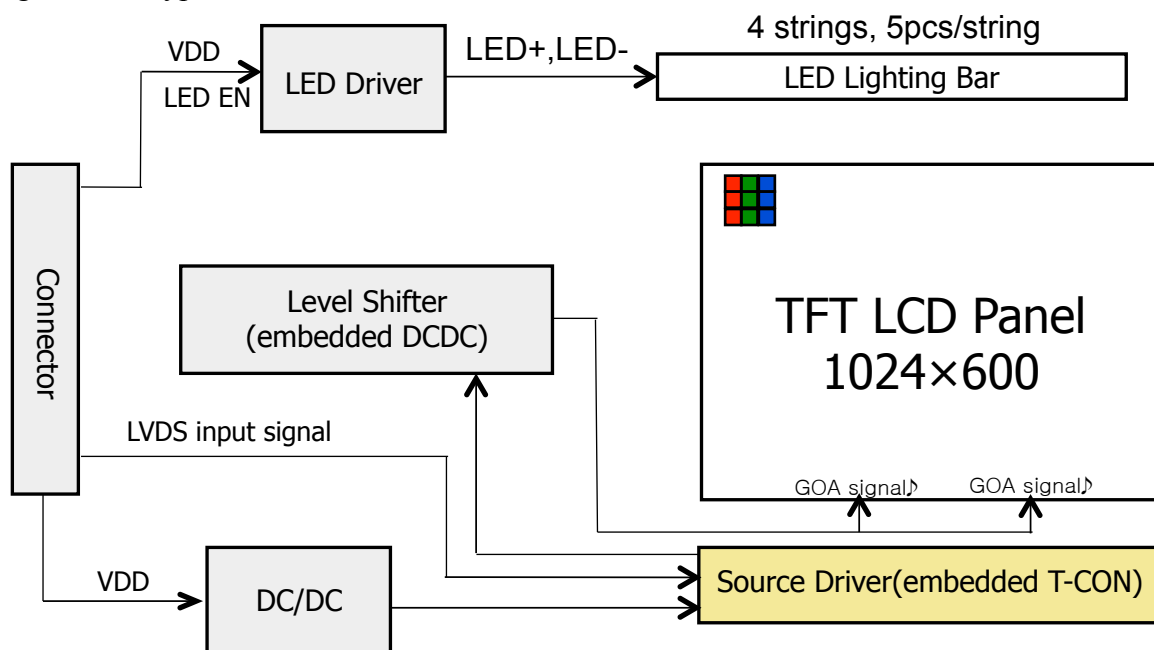

1.2 Features

- **1 Channel LVDS Interface with 1 pixel/clock**
- Thin and light weight
- Data enable signal mode
- Display 16.7M colors (Hi FRC)
- Low driving voltage and low power consumption
- RoHS Compliant

1.3 Application

- AV application Products

1.4 General Specification

The followings are general specifications at the model BA070WS1-500. (listed in Table 1.)

< Table 1. General Specifications >

Parameter	Specification	Unit	Remarks
Active area	153.6(H) x 90(V)♪	mm	
Number of pixels	1024(H) × 600(V)	pixels	
Pixel pitch	50(H) × RGB × 150(V)	μm	
Pixel arrangement	Pixels RGB stripe arrangement		
Display colors	16.7M(8bits)	colors	
Display mode	Normally Black		
Outline Dimension	164.05(H) × 100.86(V) × 2.35 (body) (typ.)	mm	Tolerance:±0.15 mm
Weight	90g (max.)	gram	
Power Consumption	P_D : 0.65(max.)	Watt	@R/G/B pattern♪
	P_{BL} : 1.55(max.)		
	P_{total} : 2.2(max.)		
Surface Treatment	3H HC + LR		

2.0 ABSOLUTE MAXIMUM RATINGS

The followings are maximum values which, if exceed, may cause faulty operation or damage to the unit. The operational and non-operational maximum voltage and current values are listed in Table 2.

< Table 2. Absolute Maximum Ratings >

[VSS=GND=0V]

Parameter	Symbol	Min.	Max.	Unit	Remarks
Power Supply Voltage	V_{DD}	-0.3	4.2	V	
Power Supply For LED	V_{LED}	-0.3	40	V	
Operating Temperature	T_{OP}	-20	+65	°C	
Storage Temperature	T_{ST}	-40	+85	°C	

Note : 1) Temperature and relative humidity range are shown in the figure below.
Wet bulb temperature should be 39 °C max. and no condensation of water.

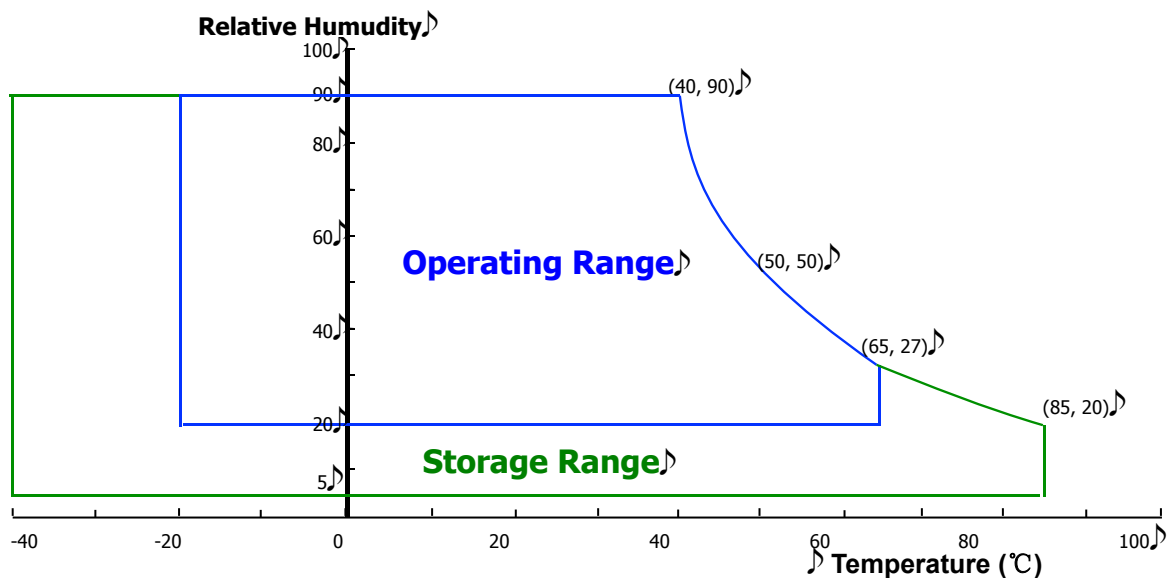

3.0 ELECTRICAL SPECIFICATIONS

3.1 Electrical Specifications

< Table 3. Electrical specifications >

[Ta = 25±2 °C]

Parameter	Symbol	Values			Unit	Notes
		Min	Typ	Max		
Power Supply Input Voltage	V _{DD}	3.2	3.7	4.2	V	Note 1
Power Supply Current	I _{DD}	-	151	-	mA	
LED Driver Power Supply Voltage	H _{VDD}	3	3.7	18	V	Note 2
LED Driver Power Supply Current	I _{HVDD}	-	405	-	mA	
LED Driver Efficiency	η	-	84	-	%	
Positive-going Input Threshold Voltage	V _{IT+}	-	-	+100	mV	V _{com} = 1.2V typ.
Negative-going Input Threshold Voltage	V _{IT-}	-100	-	-	mV	
Differential input common mode voltage	V _{com}	-	1.2	-	V	V _{IH} =100mV, V _{IL} =-100mV
Power Consumption	P _D	-	0.56	0.65	W	@ White pattern
	P _{BL}	-♪	1.50	1.55	W	
	P _{Total}	-♪	2.06	2.2	W	

Notes : 1. The supply voltage is measured and specified at the interface connector of LCM.

The current draw and power consumption specified is for 3.7V at 25 °C

2. Calculated value for reference (VLED X ILED)

3. CTF of Power Supply Current: PD /PBL

3.2 Recommended Driving Condition for Backlight

< Table 4. Electrical specifications for Backlight >

ITEM	Symbol	Min	Typ	Max	Unit	Note
Current for each LED	I_{LED}	-		20	mA	
Voltage for each LED	V_{LED}		3	3.3	V	
Input Current	I_B	-		80	mA	Total 20 LEDs, 4 Springs, 5 EA each spring)
Input Voltage	V_B		15	16.5	V	
Power Consumption for Backlight	P_B		1.50	1.55	W	

3.3 LED Driver

- With LED Driver on Customer System , We only have one connector on FPC .

4.0 OPTICAL SPECIFICATION

4.1 Overview

The test of view angle range shall be measured in a dark room (ambient luminance ≤ 11 ux and temperature = $25 \pm 2^\circ\text{C}$) with the equipment of Luminance meter system (Goniometer system and TOPCON BM-5A) and test unit shall be located at an approximate distance 50cm from the LCD surface at a viewing angle of θ and Φ equal to 0° . We refer to $\theta\Phi=0$ ($=\theta_3$) as the 3 o'clock direction (the "right"), $\theta\Phi=90$ ($=\theta_{12}$) as the 12 o'clock direction ("upward"), $\theta\Phi=180$ ($=\theta_9$) as the 9 o'clock direction ("left") and $\theta\Phi=270$ ($=\theta_6$) as the 6 o'clock direction ("bottom"). While scanning θ and/or Φ , the center of the measuring spot on the Display surface shall stay fixed. The luminance, color and uniformity should be tested by CA210. The backlight should be operating for 30 minutes prior to measurement. VDD shall be $3.7 \pm 0.5\text{V}$ at 25°C . Optimum viewing angle direction is 6 o'clock.

4.2 Optical Specifications

<Table 5. Optical Specifications>

Parameter		Symbol	Condition	Min	Typ	Max	Unit	Remark
Viewing Angle	Horizontal	θ_3	CR > 10	-	80	-	Deg.	Note 1
		θ_9		-	80	-	Deg.	
	Vertical	θ_{12}		-	80	-	Deg.	
		θ_6		-	80	-	Deg.	
Color Gamut				-	50	-	%	NTSC
Contrast ratio		CR		700:1	900:1	-		Note 2
Luminance of White		Y_w		340	400	-	cd/m ²	Note 3
White luminance uniformity		ΔY_9		80	90		%	Note 4
Reproduction of color	White	W_x	$\theta = 0^\circ$ (Center) Normal Viewing Angle	TYP. - 0.03	0.297	TYP. + 0.03		CF + C light
		W_y			0.337			
	Red	R_x			0.618			
		R_y			0.328			
	Green	G_x			0.282			
		G_y			0.538			
	Blue	B_x			0.142			
		B_y			0.168			
Response Time		T_g		-	30	-	ms	Note 6
Gamma Scale				2.0	2.2	2.4		



Notes : 1. Viewing angle is the angle at which the contrast ratio is greater than 10. The viewing angles are determined for the horizontal or 3, 9 o'clock direction and the vertical or 6, 12 o'clock direction with respect to the optical axis which is normal to the LCD surface (see FIGURE 1).

2. Contrast measurements shall be made at viewing angle of $\Theta = 0$ and at the center of the LCD surface. Luminance shall be measured with all pixels in the view field set first to white, then to the dark (black) state. (see FIGURE 1) Luminance Contrast Ratio (CR) is defined mathematically.

$$CR = \frac{\text{Luminance when displaying a white raster}}{\text{Luminance when displaying a black raster}}$$

3. Center Luminance of white is defined as luminance values of 5point average across the LCD surface. Luminance shall be measured with all pixels in the view field set first to white. This measurement shall be taken at the locations shown in FIGURE 2 for a total of the measurements per display.

The luminance is measured by CA210 when the LED current is set at 18.8m.

4. The White luminance uniformity on LCD surface is then expressed as : $\Delta Y = \text{Minimum Luminance of 5 points} / \text{Maximum Luminance of 5 points}$ (see FIGURE 2).

5. The color chromaticity coordinates specified in Table 5 shall be calculated from the spectral data measured with all pixels first in red, green, blue and white. Measurements shall be made at the center of the panel.

6. The electro-optical response time measurements shall be made as FIGURE 3 by switching the "data" input signal ON and OFF. The times needed for the luminance to change from 10% to 90% is T_r , and 90% to 10% is T_d .

7. Cross-Talk of one area of the LCD surface by another shall be measured by comparing the luminance (YA) of a 25mm diameter area, with all display pixels set to a gray level, to the luminance (YB) of that same area when any adjacent area is driven dark. (See FIGURE 4).

4.3 Optical measurements

Figure 1. Measurement Set Up

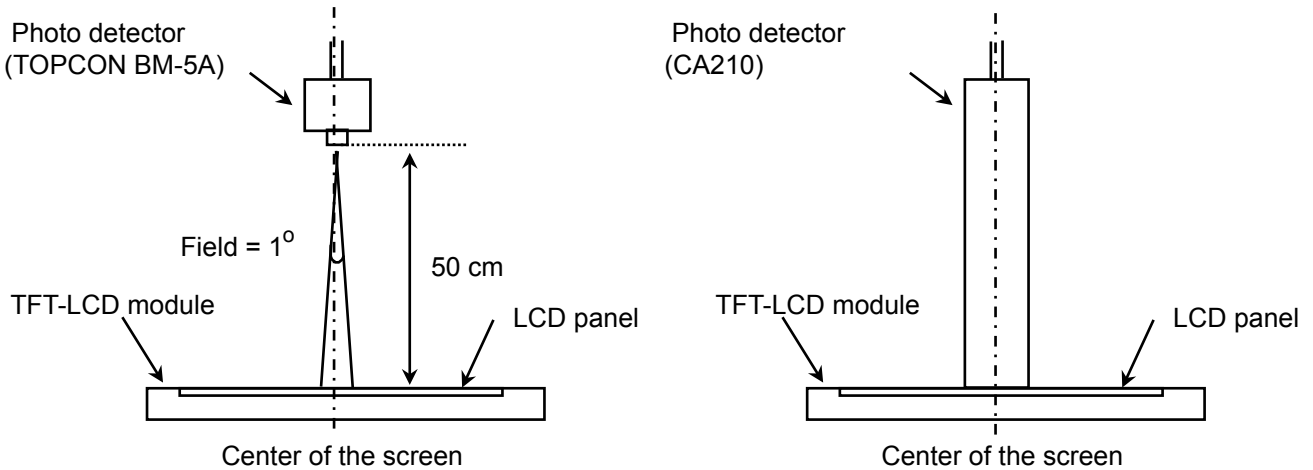

View angle range measurement setup Luminance , uniformity and color measurement setup

Figure 2. White Luminance and Uniformity Measurement Locations (9 points)

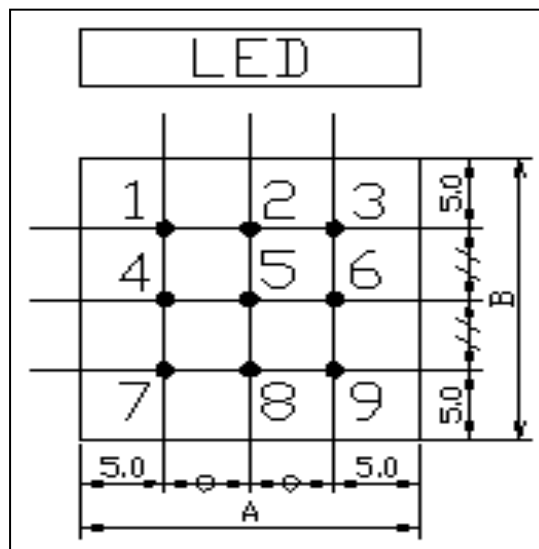

The White luminance uniformity on LCD surface is then expressed as : $\Delta Y9 = \text{Minimum Luminance of nine points} / \text{Maximum Luminance of nine points}$ (see FIGURE 3)

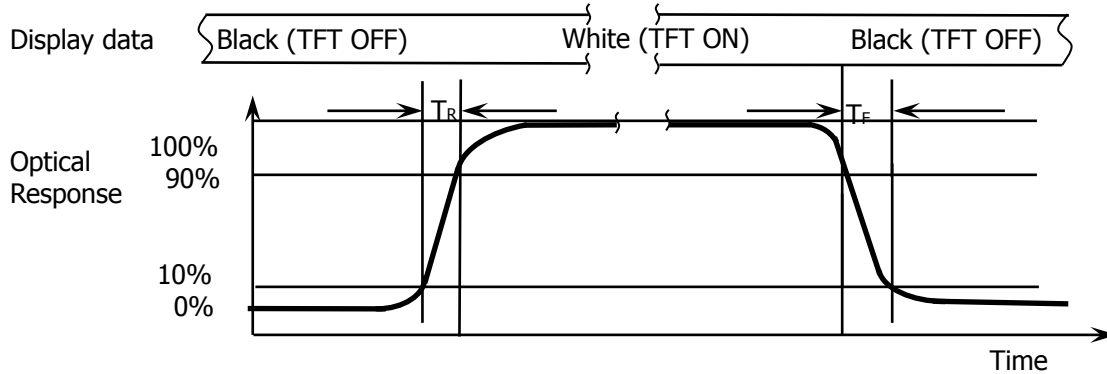
Figure 3. Response Time Testing

The electro-optical response time measurements shall be made as shown in FIGURE 3 by switching the “data” input signal ON and OFF. The times needed for the luminance to change from 10% to 90% is T_r and 90% to 10% is T_d .

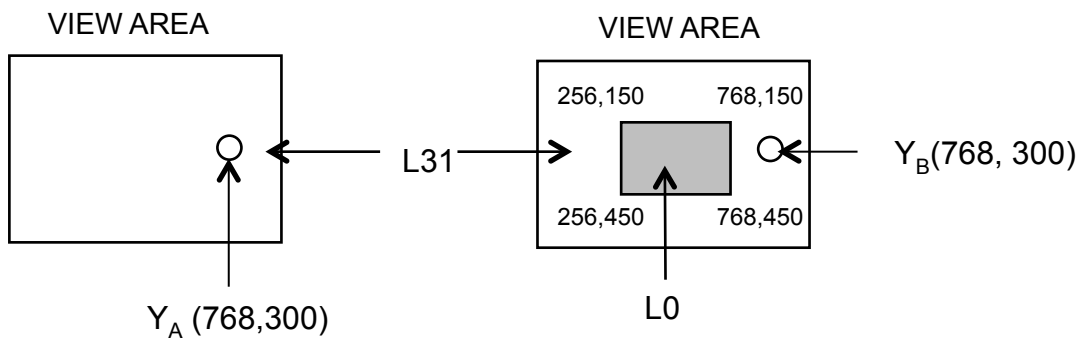
Figure 4. Cross Modulation Test Description

$$\text{Cross-Talk (\%)} = \left| \frac{Y_B - Y_A}{Y_A} \right| \times 100$$

Where:

Y_A = Initial luminance of measured area (cd/m^2)

Y_B = Subsequent luminance of measured area (cd/m^2)

The location measured will be exactly the same in both patterns

Cross-Talk of one area of the LCD surface by another shall be measured by comparing the luminance (Y_A) of a 25mm diameter area, with all display pixels set to a gray level, to the luminance (Y_B) of that same area when any adjacent area is driven dark (Refer to FIGURE 4).

5.0 INTERFACE CONNECTION.

5.1 Electrical Interface Connection

The electronics interface connector is PF030-B31B-N09.

The connector interface pin assignments are listed in Table 6.

<Table 6. Pin Assignments for the Interface Connector>

Terminal	Symbol	Functions
Pin No.	Symbol	Description
1	VDDIN	Power supply VDDIN=3.7V (Typ.)
2	VDDIN	
3	VDDIN	
4	VDDIN	
5	VDDIN	
6	VDDIN	
7	VDDIN	
8	NC	Non Connection
9	NC [Ⓝ]	Non Connection
10	NC [Ⓝ]	Non Connection
11	GND	GROUND
12	GND [Ⓝ]	GROUND [Ⓝ]
13	RIN0-	LVDS Negative data signal (-)
14	RIN0+	LVDS Positive data signal (+)
15	GND [Ⓝ]	GROUND [Ⓝ]
16	RIN1-	LVDS Negative data signal (-)
17	RIN1+	LVDS Positive data signal (+)
18	GND [Ⓝ]	GROUND [Ⓝ]
19	RIN2-	LVDS Negative data signal (-)
20	RIN2+	LVDS Positive data signal (+)
21	GND [Ⓝ]	GROUND
22	LVDS_CLK-	LVDS Negative CLK signal (-)
23	LVDS_CLK+	LVDS Positive CLK signal (+)
24	GND [Ⓝ]	GROUND
25	RIN3-	LVDS Negative data signal (-)
26	RIN3+	LVDS Positive data signal (+)
27	GND [Ⓝ]	GROUND [Ⓝ]
28	LED_EN [Ⓝ]	LED enable
29	GND	GROUND
30	DVDDT [Ⓝ]	Only for SEC test. Other customers NC [Ⓝ]
31	GND [Ⓝ]	GROUND

5-2. LVDS Interface

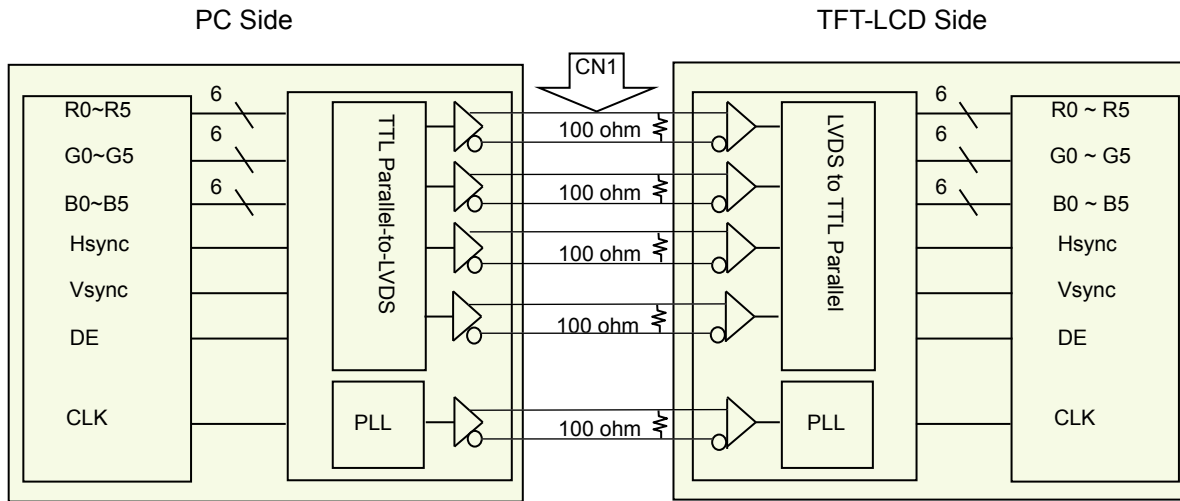

5.3.LVDS Input signal

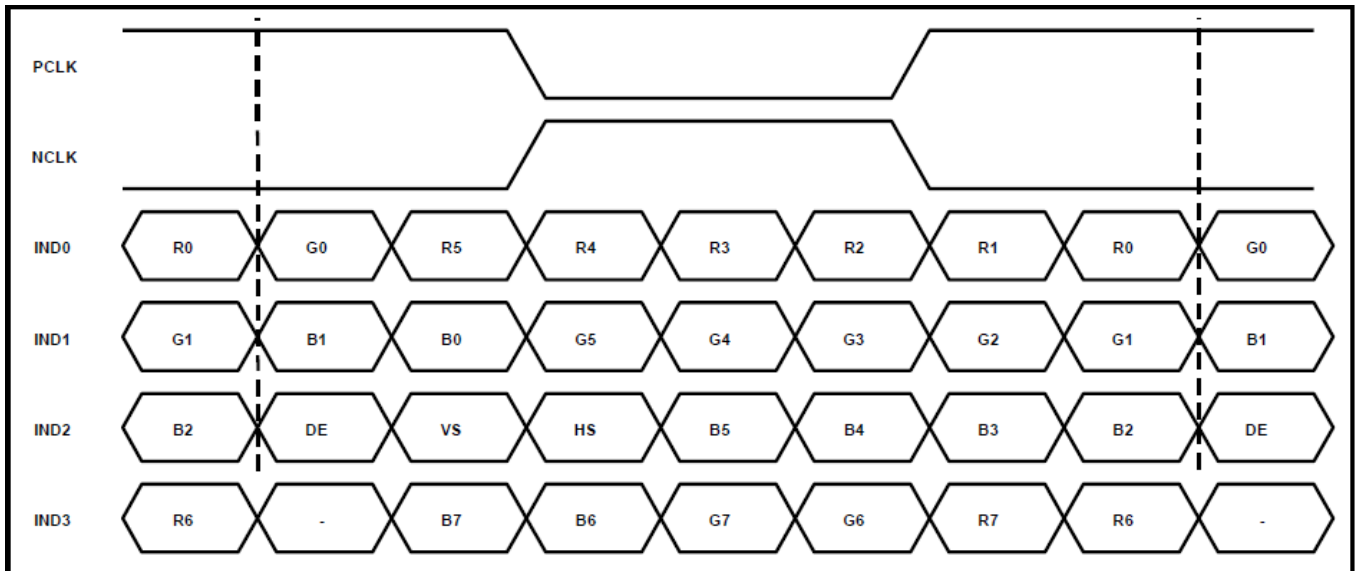

5.4 Data Input Format

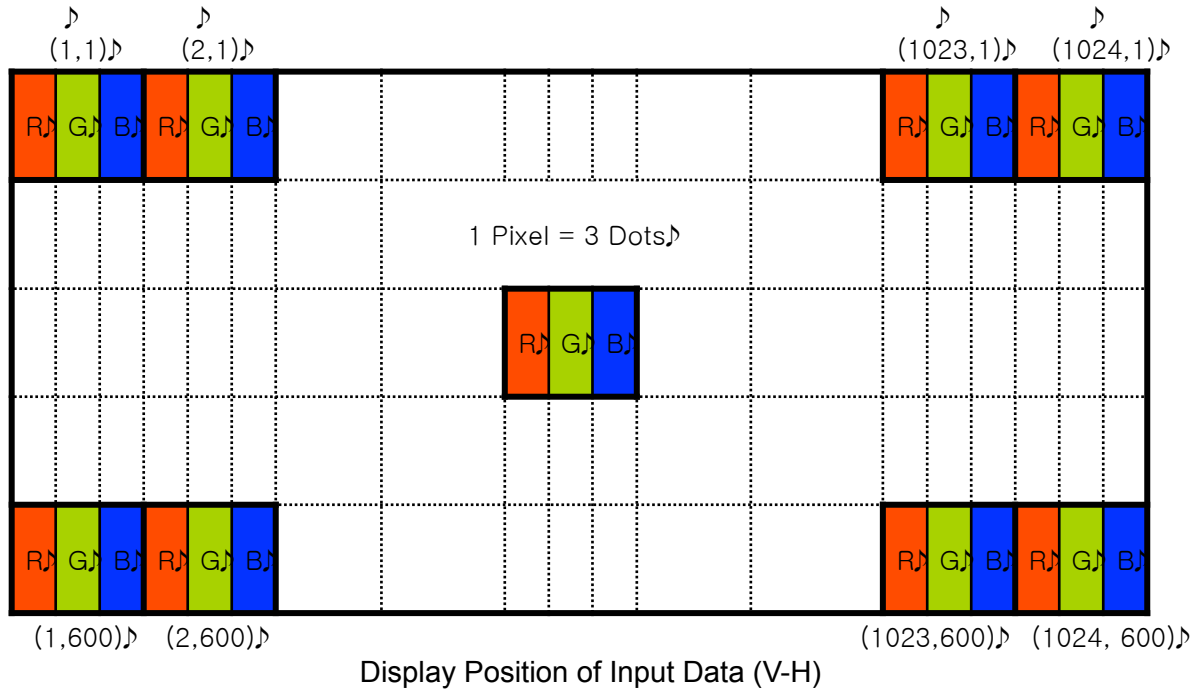

6.0 SIGNAL TIMING SPECIFICATION

6.1 The BP070WS1-500 is operated by the DE only.

Item		Symbols	Min	Typ	Max	Unit
Clock	Frequency	1/Tc	40.8	51.2	67.2	MHz
	High Time	Tch	40%	50%	60%	Tc
	Low Time	Tcl	60%	50%	40%	Tc
Frame Period		Tv	610	635	800	lines
			60	60	60	Hz
			16.6	16.6	16.6	ms
Vertical Display Period		Tvd	600	600	600	lines
One line Scanning Period		Th	1114	1344	1400	clocks
Horizontal Display Period		Thd	1024	1024	1024	clocks

6.2 LVDS Rx Interface Timing Parameter

The specification of the LVDS Rx interface timing parameter is shown in Table 8.

<Table 8. LVDS Rx Interface Timing Specification>

Item	Symbol	Min	Typ	Max	Unit	Remark
CLKIN Period	tRCIP	14.88	19.53	24.51	nsec	
Input Data 0	tRIP1	-0.4	0.0	+0.4	nsec	
Input Data 1	tRIP0	tRCIP/7-0.4	tRCIP/7	tRCIP/7+0.4	nsec	
Input Data 2	tRIP7	2 × tRCIP/7-0.4	2 × tRCIP/7	2 × tRCIP/7+0.4	nsec	
Input Data 3	tRIP6	3 × tRCIP/7-0.4	3 × tRCIP/7	3 × tRCIP/7+0.4	nsec	
Input Data 4	tRIP5	4 × tRCIP/7-0.4	4 × tRCIP/7	4 × tRCIP/7+0.4	nsec	
Input Data 5	tRIP4	5 × tRCIP/7-0.4	5 × tRCIP/7	5 × tRCIP/7+0.4	nsec	
Input Data 6	tRIP3	6 × tRCIP/7-0.4	6 × tRCIP/7	6 × tRCIP/7+0.4	nsec	
Input Data 7	tRIP2	7 × tRCIP/7-0.4	7 × tRCIP/7	7 × tRCIP/7+0.4	nsec	

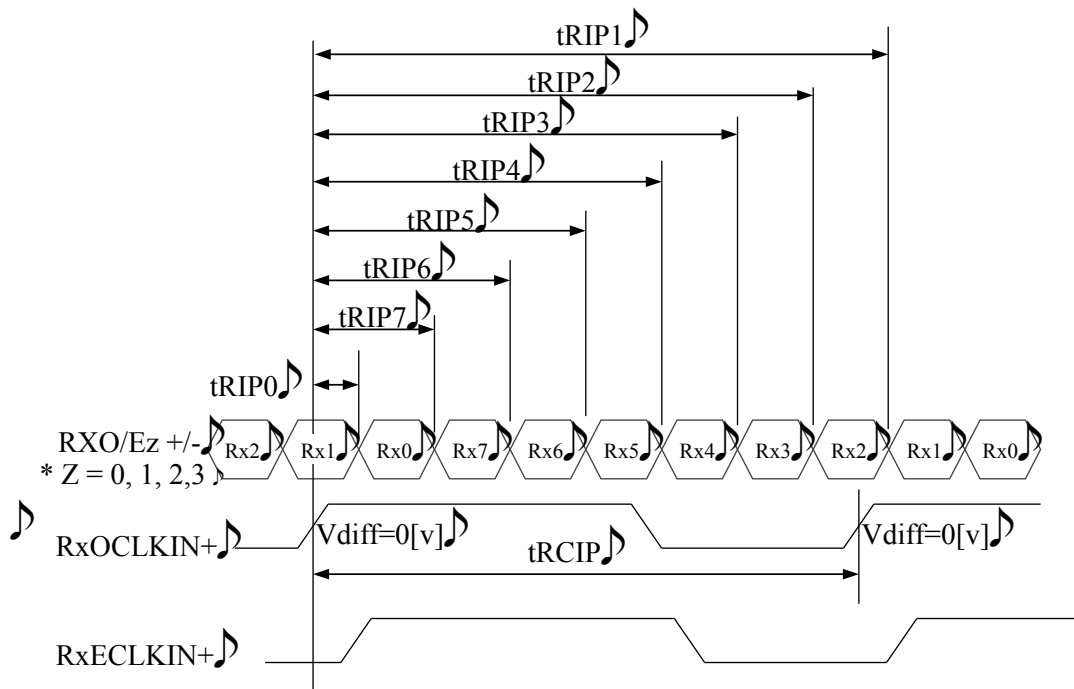

$$* V_{diff} = (RXO/Ez+) - (RXO/Ez-), \dots, (RXO/ECLK+) - (RXO/ECLK-)$$

7.0 SIGNAL TIMING WAVEFORMS OF INTERFACE SIGNAL

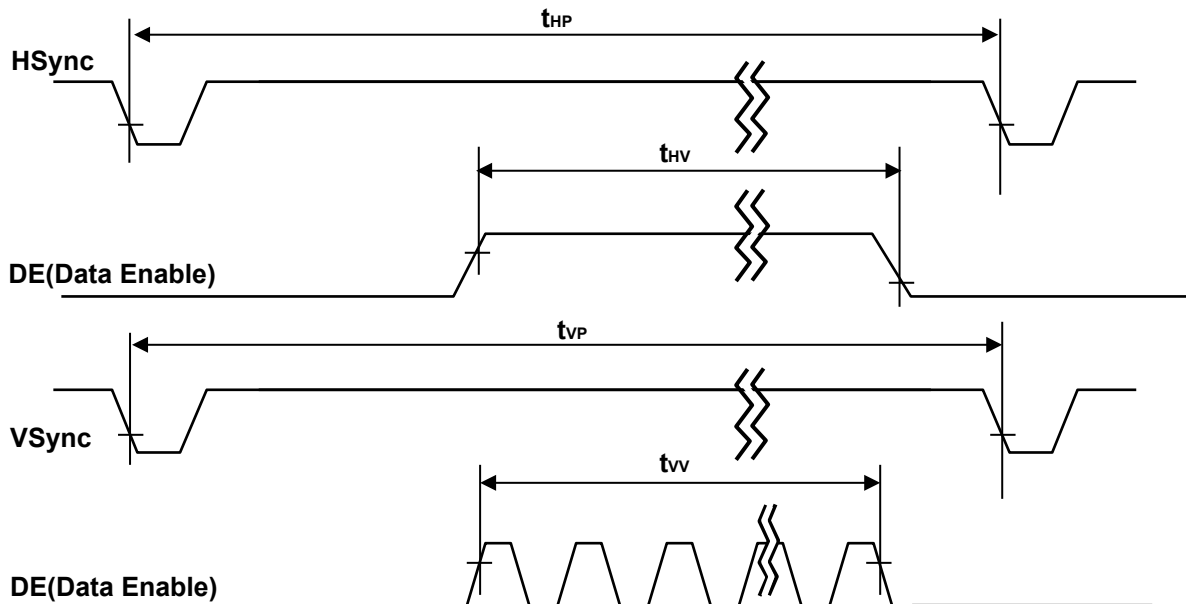
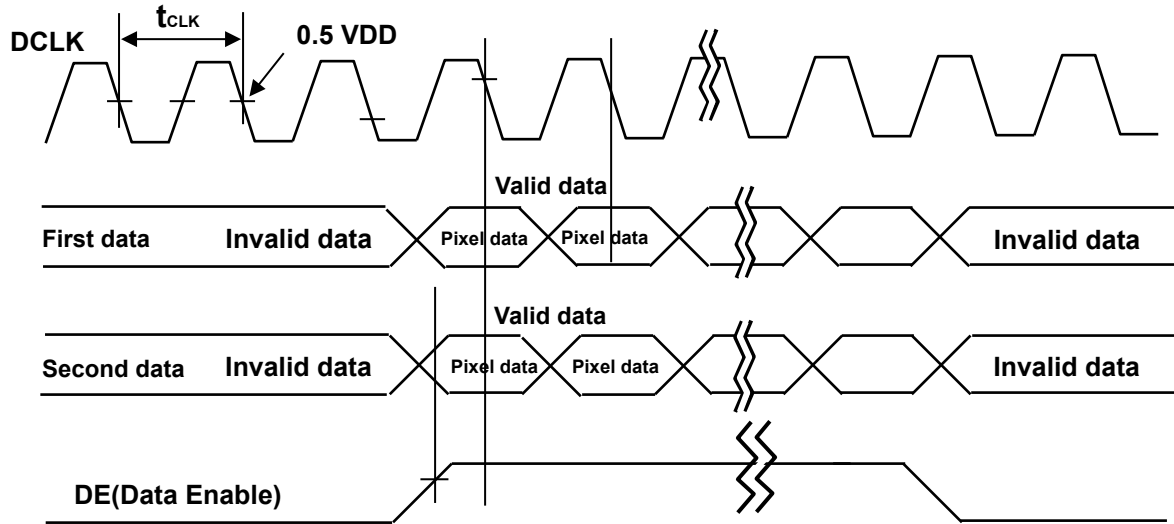



PRODUCT GROUP

REV

ISSUE DATE

TFT LCD PRODUCT

0

2013.3.18.

8.0 INPUT SIGNALS, BASIC DISPLAY COLORS & GRAY SCALE OF COLORS

Color & Gray Scale		Input Data Signal																							
		Red Data								Green Data				Blue Data											
		R7	R6	R5	R4	R3	R2	R1	R0	G7	G6	G5	G4	G3	G2	G1	G0	B7	B6	B5	B4	B3	B2	B1	B0
Basic Colors	Black	0	0	0	0	0	0	0	0	0	0	0	0	0	0	0	0	0	0	0	0	0	0	0	
	Blue	0	0	0	0	0	0	0	0	0	0	0	0	0	0	0	0	1	1	1	1	1	1	1	1
	Green	0	0	0	0	0	0	0	0	1	1	1	1	1	1	1	1	0	0	0	0	0	0	0	0
	Cyan	0	0	0	0	0	0	0	0	1	1	1	1	1	1	1	1	1	1	1	1	1	1	1	1
	Red	1	1	1	1	1	1	1	1	0	0	0	0	0	0	0	0	0	0	0	0	0	0	0	0
	Magenta	1	1	1	1	1	1	1	1	0	0	0	0	0	0	0	0	1	1	1	1	1	1	1	1
	Yellow	1	1	1	1	1	1	1	1	1	1	1	1	1	1	1	1	0	0	0	0	0	0	0	0
	White	1	1	1	1	1	1	1	1	1	1	1	1	1	1	1	1	1	1	1	1	1	1	1	1
Gray Scale of Red	Black	0	0	0	0	0	0	0	0	0	0	0	0	0	0	0	0	0	0	0	0	0	0	0	
	△	0	0	0	0	0	0	0	1	0	0	0	0	0	0	0	0	0	0	0	0	0	0	0	
	Darker	0	0	0	0	0	0	1	0	0	0	0	0	0	0	0	0	0	0	0	0	0	0	0	
	△	↑								↑				↑											
	▽	↓								↓				↓											
	Brighter	1	1	1	1	1	1	0	1	0	0	0	0	0	0	0	0	0	0	0	0	0	0	0	0
	▽	1	1	1	1	1	1	1	0	0	0	0	0	0	0	0	0	0	0	0	0	0	0	0	0
	Red	1	1	1	1	1	1	1	1	0	0	0	0	0	0	0	0	0	0	0	0	0	0	0	0
Gray Scale of Green	Black	0	0	0	0	0	0	0	0	0	0	0	0	0	0	0	0	0	0	0	0	0	0	0	
	△	0	0	0	0	0	0	0	0	0	0	0	0	0	0	0	1	0	0	0	0	0	0	0	
	Darker	0	0	0	0	0	0	0	0	0	0	0	0	0	0	1	0	0	0	0	0	0	0	0	
	△	↑								↑				↑											
	▽	↓								↓				↓											
	Brighter	0	0	0	0	0	0	0	0	1	1	1	1	1	1	0	1	0	0	0	0	0	0	0	0
	▽	0	0	0	0	0	0	0	0	1	1	1	1	1	1	1	0	0	0	0	0	0	0	0	0
	Green	0	0	0	0	0	0	0	0	1	1	1	1	1	1	1	1	0	0	0	0	0	0	0	0
Gray Scale of Blue	Black	0	0	0	0	0	0	0	0	0	0	0	0	0	0	0	0	0	0	0	0	0	0	0	
	△	0	0	0	0	0	0	0	0	0	0	0	0	0	0	0	0	0	0	0	0	0	0	1	
	Darker	0	0	0	0	0	0	0	0	0	0	0	0	0	0	0	0	0	0	0	0	0	0	1	0
	△	↑								↑				↑											
	▽	↓								↓				↓											
	Brighter	0	0	0	0	0	0	0	0	0	0	0	0	0	0	0	1	1	1	1	1	1	1	0	1
	▽	0	0	0	0	0	0	0	0	0	0	0	0	0	0	0	1	1	1	1	1	1	1	1	0
	Blue	0	0	0	0	0	0	0	0	0	0	0	0	0	0	0	1	1	1	1	1	1	1	1	1
Gray Scale of White	Black	0	0	0	0	0	0	0	0	0	0	0	0	0	0	0	0	0	0	0	0	0	0	0	
	△	0	0	0	0	0	0	0	1	0	0	0	0	0	0	0	1	0	0	0	0	0	0	1	
	Darker	0	0	0	0	0	0	1	0	0	0	0	0	0	0	1	0	0	0	0	0	0	0	1	0
	△	↑								↑				↑											
	▽	↓								↓				↓											
	Brighter	1	1	1	1	1	1	0	1	1	1	1	1	1	1	0	1	1	1	1	1	1	1	0	1
	▽	1	1	1	1	1	1	1	0	1	1	1	1	1	1	1	0	1	1	1	1	1	1	1	0
	White	1	1	1	1	1	1	1	1	1	1	1	1	1	1	1	1	1	1	1	1	1	1	1	1

SPEC. NUMBER
S)

SPEC TITLE
BP070WS1-500 Product Specification

PAGE
19 OF 28

9.0 POWER SEQUENCE

To prevent a latch-up or DC operation of the LCD module, the power on/off sequence shall be as shown in below

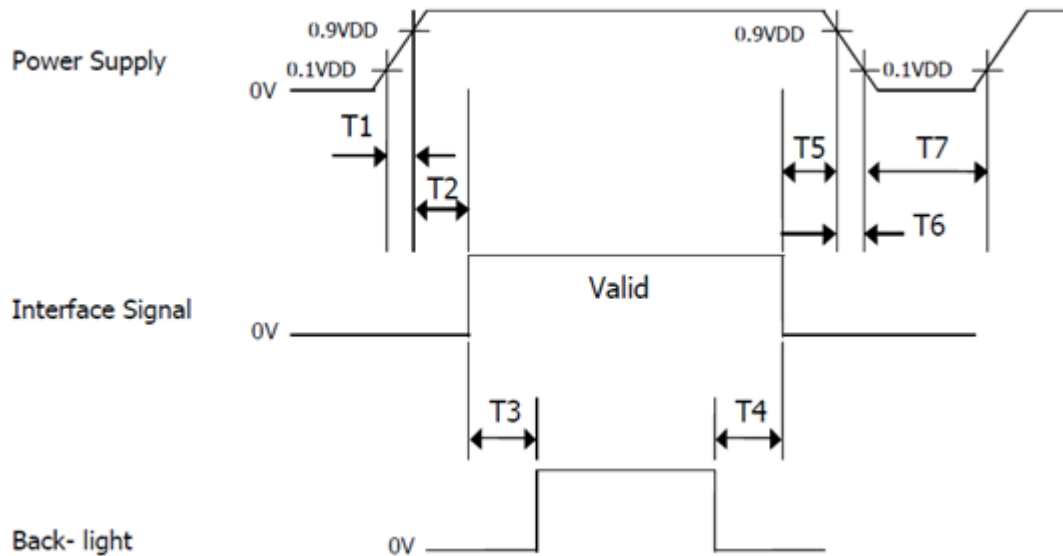

Parameter	Values			Units
	Min	Typ	Max	
T1	0.5	-	10	ms
T2	0	-	50	ms
T3	200	-	-	ms
T4	200	-	-	ms
T5	0.5	-	50	ms
T6	0	-	10	ms
T7	500	-	-	ms

Notes:

1. When the power supply VDD is 0V, keep the level of input signals on the low or keep high impedance.
2. Do not keep the interface signal high impedance when power is on. Back Light must be turn on after power for logic and interface signal are valid.



10.0 Connector Description

Physical interface is described as for the connector on LCM.

These connectors are capable of accommodating the following signals and will be following components.

10.1 TFT LCD Module

Connector Name /Description	For Signal Connector
Manufacturer	UJU or Compatible
Type/ Part Number	PF030-B31B-N09 or Compatible

10.2 LED Connector

Pin No.	Symbol	For Signal Connector
1	VLEDP	LED Anode Power Supply
2	VLEDN1	LED Cathode Power Supply
3	VLEDN2	
4	VLEDN3	
5	VLEDN4	



11.0 MECHANICAL CHARACTERISTICS

11.1 Dimensional Requirements

FIGURE 5 shows mechanical outlines for the model BP070WS1-500.
Other parameters are shown in Table 9.

<Table 9. Dimensional Parameters>

Parameter	Specification	Unit
Active Area	153.6 (H) ×90 (V)	
Number of pixels	1024(H) X600 (V) (1 pixel = R + G + B dots)	
Pixel pitch	0.150 (H) X 0.150 (V)	
Pixel arrangement	RGB Vertical stripe	
Display colors	16.7M	
Display mode	Normally Black	
Dimensional outline	164.05*100.86*2.35 (Typ.)	mm
Weight	90 (Max)	gram
Back-light	LED, Horizontal-LED Array type	

11.2 Mounting

See FIGURE 6.

11.3 Glare and Polarizer Hardness.

The surface of the LCD has an low reflection coating and hard coating to reduce scratching.

11.4 Light Leakage

There shall not be visible light from the back-lighting system around the edges of the screen as seen from a distance 50cm from the screen with an overhead light level of 150lux.

12.0 RELIABILITY TEST

The Reliability test items and its conditions are shown in below.

<Table 10. Reliability test>

No	Test Items	Conditions
1	High temperature storage test	Ta = 85 °C, 24 hrs
2	Low temperature storage test	Ta = -40 °C, 24 hrs
3	High temperature & high humidity operation test	Ta = 60 °C, 90%RH, 96 hrs
4	High temperature operation test	Ta = 60 °C, 24 hrs
5	Low temperature operation test	Ta = -20 °C, 24 hrs
6	Thermal shock	Ta = -40 °C ↔ 85 °C (2 hr), 30 cycle

13.0 HANDLING & CAUTIONS

(1) Cautions when taking out the module

- Pick the pouch only, when taking out module from a shipping package.

(2) Cautions for handling the module

- As the electrostatic discharges may break the LCD module, handle the LCD module with care. Peel a protection sheet off from the LCD panel surface as slowly as possible.
- As the LCD panel and back - light element are made from fragile glass material, impulse and pressure to the LCD module should be avoided.
- As the surface of the polarizer is very soft and easily scratched, use a soft dry cloth without chemicals for cleaning.
- Do not pull the interface connector in or out while the LCD module is operating.
- Put the module display side down on a flat horizontal plane.
- Handle connectors and cables with care.

(3) Cautions for the operation

- When the module is operating, do not lose CLK, ENAB signals. If any one of these signals is lost, the LCD panel would be damaged.
- Obey the supply voltage sequence. If wrong sequence is applied, the module would be damaged.



PRODUCT GROUP

REV

ISSUE DATE

TFT LCD PRODUCT

0

2013.3.18.

(4) Cautions for the atmosphere

- Dew drop atmosphere should be avoided.
- Do not store and/or operate the LCD module in a high temperature and/or humidity atmosphere. Storage in an electro-conductive polymer packing pouch and under relatively low temperature atmosphere is recommended.

(5) Cautions for the module characteristics

- Do not apply fixed pattern data signal to the LCD module at product aging.
- Applying fixed pattern for a long time may cause image sticking.

(6) Other cautions

- Do not disassemble and/or re-assemble LCD module.
- Do not re-adjust variable resistor or switch etc.
- When returning the module for repair or etc., Please pack the module not to be broken. We recommend to use the original shipping packages.

14.0 LABEL

(1) Product label



1 2 3 4 5 6 7

X	X	X	X	X	X	1	0	0	X	X	X	X	X	X	X
---	---	---	---	---	---	---	---	---	---	---	---	---	---	---	---

Type designation

No 5. Month (1, 2, 3, ..., 9, X, Y, Z)

No 1. Control Number

No 6. Product Identification (FG)

No 2. Rank / Grade

No 7. Serial Number

No 3. Line classification (BOE OT:A/BC)

No 4. Year (10 : 2010, 11: 2011, ...)

SPEC. NUMBER
S

SPEC TITLE
BP070WS1-500 Product Specification

PAGE
24 OF 28



PRODUCT GROUP

REV

ISSUE DATE

TFT LCD PRODUCT

0

2013.3.18.

(2) High voltage caution label

	<p>HIGH VOLTAGE CAUTION</p>	<p>COLD CATHODE FLUORESCENT LAMP IN LCD PANEL CONTAINS A SMALL AMOUNT OF MERCURY. PLEASE FOLLOW LOCAL OR- DINANCES OR REGULATIONS FOR DISPOSAL.</p>
	<p>RISK OF ELECTRIC SHOCK, DISCONNECT THE ELECTRIC POWER BEFORE SERVICING</p>	

(3) Box label

Label Size: 110 mm (L) × 56 mm (W)

Contents

Model: BP070WS1-500

Q`ty: Module Q`ty in one box

Serial No.: Box Serial No. See next figure for detail description.

Date: Packing Date

Internal use of Product



<u>00</u>	<u>0</u>	<u>0</u>	<u>00</u>	<u>0</u>	<u>0000</u>	<u>000000</u>
Type	Grade	Line	Year	Month	Internal use	Serial No

SPEC. NUMBER
S)

SPEC TITLE
BP070WS1-500 Product Specification

PAGE
25 OF 28

15.0 PACKING INFORMATION

15.1 Packing order

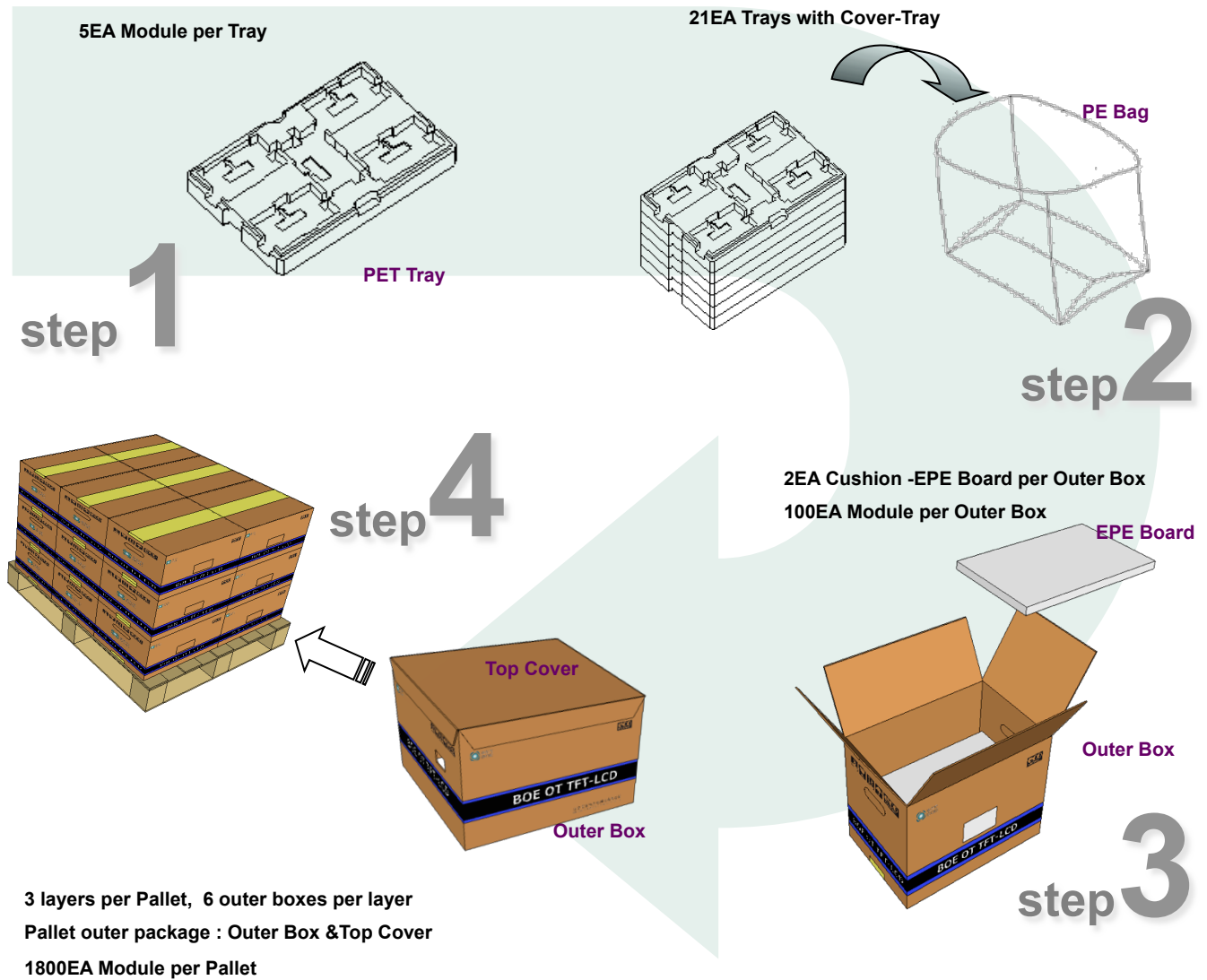

15.2 Notes

- Box Dimension: 515mm(W) x 350mm(D) x 265mm(H)
- Package Quantity in one Box: 100pcs
- Total Weight: **9.66** kg

16.0 MECHANICAL OUTLINE DIMENSION

Figure 6. TFT-LCD Module Outline Dimension (Front View)

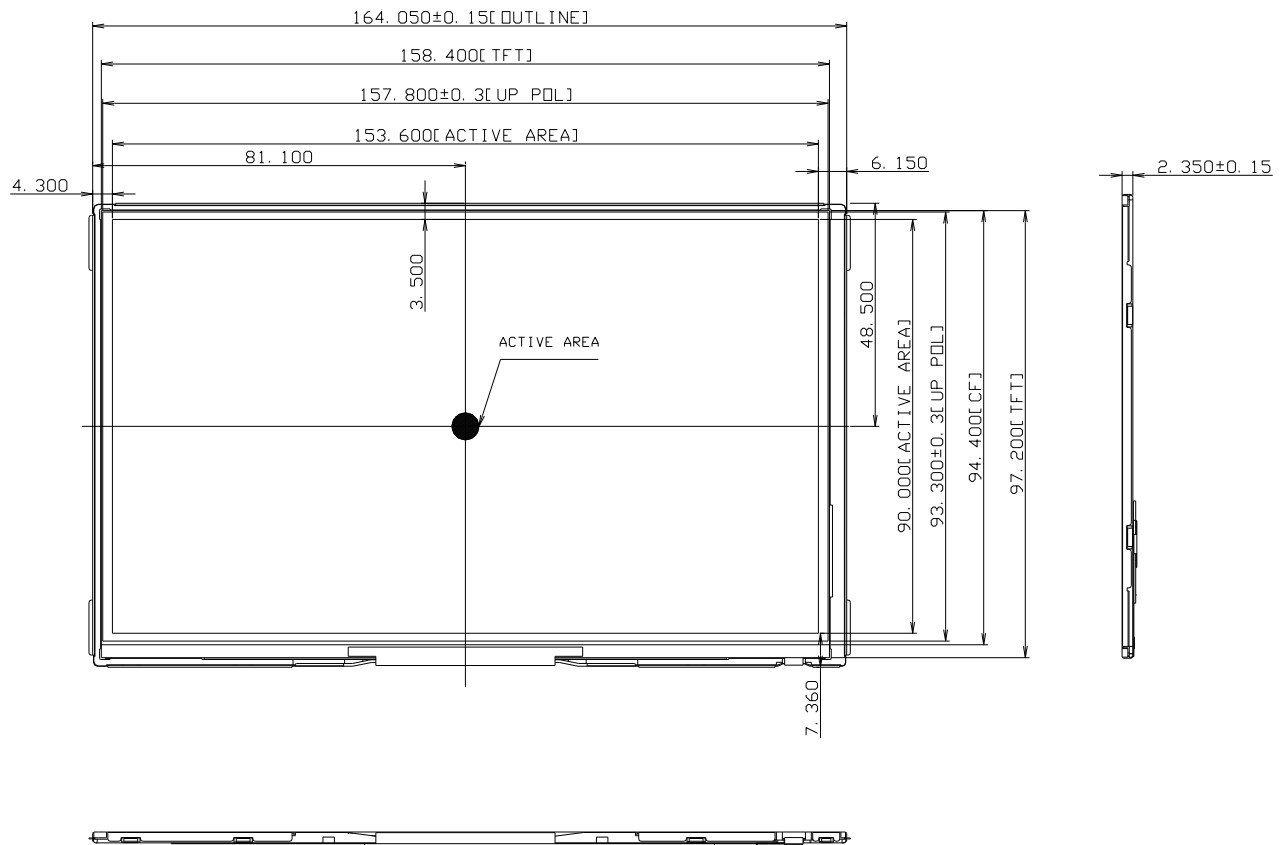

Figure 7. TFT-LCD Module Outline Dimensions (Rear view)

