

ProLight PACJ-7FxL-xC1N
7W COB Light-Engine LEDs
Technical Datasheet
Version: 1.1

ProLight Opto ® ProEngine Series

Features

- High flux density of lighting source
- Good color uniformity
- RoHS compliant
- Energy Star binning structure, neutral white and warm white with 2 steps guarantee.
- More energy efficient than incandescent and most halogen lamps
- No UV
- Long lifetime
- 5 year warranty

Main Applications

- Par lighting
- LED Bulb
- Ceiling lighting
- Spot lighting
- Down lighting

Introduction

·The input power is 7 Watt, the multi-chip ultra high power ProEngine Series delivers never before seen luminous flux output from a single emitter. The superficial illuminating nature of ProEngine makes them the preference in Par lighting, typical applications include commercial down lighting, LED bulb, accent lighting, ceiling lighting and spot lighting.

Emitter Mechanical Dimensions

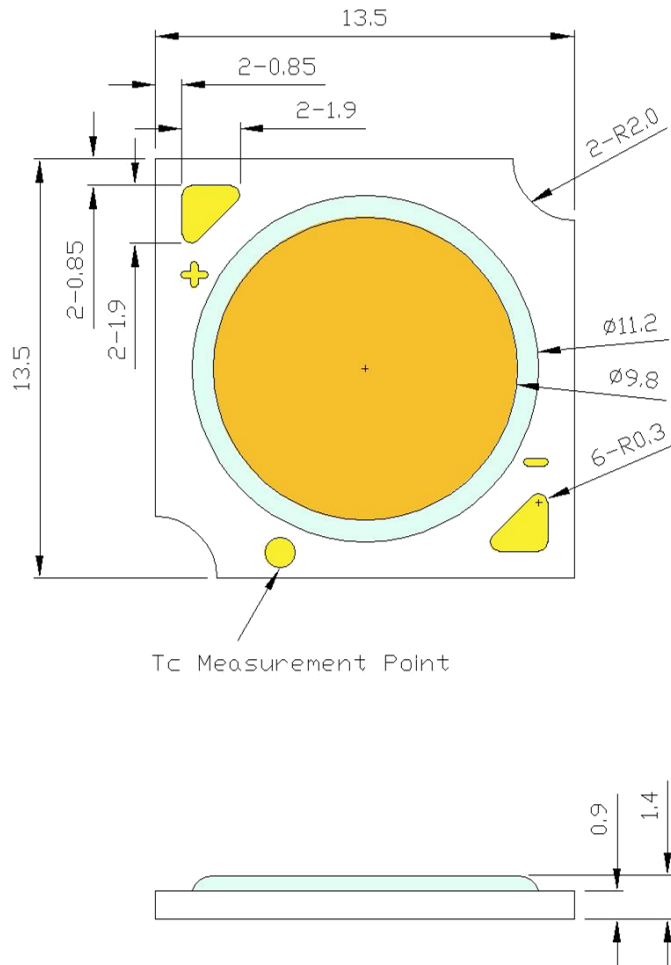

Notes:

1. Slots in aluminum-core PCB for M3 mounting screw.
2. Solder pads are labeled "+" and "-" to denote positive and negative, respectively.
3. Drawing not to scale.
4. All dimensions are in millimeters.
5. Unless otherwise indicated, tolerances are ± 0.30 mm.
6. **Please do not use a force of over 0.3kgf impact or pressure on the lens of the LED, otherwise it will cause a catastrophic failure.**

*The appearance and specifications of the product may be modified for improvement without notice.

Flux Characteristics, $T_c = 25^\circ\text{C}$

Radiation Pattern	Color	Part Number COB	DC Forward Current (mA)	Luminous Flux Φ_v (lm)		CRI Minimum
				Minimum	Typical	
Lambertian	White	PACJ-7FWL-AC1N	90*	460	525	70
			180	815	930	
	Neutral White	PACJ-7FNL-AC1N	90*	450	515	70
			180	800	910	
	Warm White	PACJ-7FVL-AC1N	90*	430	495	70
			180	760	875	
	White	PACJ-7FWL-BC1N	90*	450	515	80
			180	800	910	
	Neutral White	PACJ-7FNL-BC1N	90*	440	505	80
			180	780	895	
	Warm White	PACJ-7FVL-BC1N	90*	420	485	80
			180	740	860	
	White	PACJ-7FWL-DC1N	90*	395	455	90
			180	700	805	
	Neutral White	PACJ-7FNL-DC1N	90*	385	445	90
			180	680	790	
Warm White	PACJ-7FVL-DC1N	90*	370	430	90	
		180	655	760		
Neutral White	PACJ-7FNL-EC1N	90*	340	390	95	
		180	600	685		
Warm White	PACJ-7FVL-EC1N	90*	325	380	95	
		180	570	670		

- The mark "*" indicated product is tested and binned at the specified drive current.
- ProLight maintains a tolerance of $\pm 7\%$ on flux and power measurements.
- ProLight maintains a tolerance of ± 2 on CRI measurements.
- Please do not drive at rated current more than 1 second without proper heat sink.

Electrical Characteristics at 90mA, $T_c = 25^\circ\text{C}$

Color	Forward Voltage V_F (V)			Thermal Resistance Junction to Board ($^\circ\text{C}/\text{W}$)
	Min.	Typ.	Max.	
White	33.7	36.0	38.3	4.2
Neutral White	33.7	36.0	38.3	4.2
Warm White	33.7	36.0	38.3	4.2

- ProLight maintains a tolerance of $\pm 1\text{V}$ for Voltage measurements.

Optical Characteristics at 90mA, $T_c = 25^\circ\text{C}$

Color	Bin Code	Color Temperature CCT			Total included Angle (degrees) $\theta_{0.90\text{V}}$	Viewing Angle (degrees) $2\theta_{1/2}$
		Min.	Typ.	Max.		
White	V0	4740 K	5000 K	5310 K	160	120
	W0	5310 K	5700 K	6010 K	160	120
	X0	6020 K	6500 K	7030 K	160	120
Neutral White	S0	3900 K	4000 K	4070 K	160	120
	M0	2670 K	2700 K	2770 K	160	120
Warm White	N0	2990 K	3000 K	3090 K	160	120
	Q0	3380 K	3500 K	3550 K	160	120

- ProLight maintains a tolerance of $\pm 5\%$ for CCT measurements.

Supply Specifications

Part Number	CIR	Color Bin Code						
		V0	W0	X0	S0	M0	N0	Q0
PACJ-7F _x L-AC1N	70	V			V	V		
PACJ-7F _x L-BC1N	80	V	V	V	V	V	V	V
PACJ-7F _x L-DC1N	90	V			V	V	V	V
PACJ-7F _x L-EC1N	95				V	V	V	

Electro-Optical Characteristics, $T_c = 25^\circ\text{C}$

I_F (mA)	V_F (V)	Power (W)	PACJ-7FWL-AC1N		PACJ-7FNL-AC1N		PACJ-7FVL-AC1N	
			Flux (lm)	lm/W	Flux (lm)	lm/W	Flux (lm)	lm/W
60	34.63	2.08	390	187.5	383	184.3	368	177.1
90*	36.00	3.24	525	162.0	515	159.0	495	152.8
120	37.23	4.47	660	147.7	647	144.7	622	139.1
150	38.42	5.76	795	138.0	778	135.1	748	129.9
180	39.53	7.11	930	130.8	910	128.0	875	123.1
I_F (mA)	V_F (V)	Power (W)	PACJ-7FWL-BC1N		PACJ-7FNL-BC1N		PACJ-7FVL-BC1N	
			Flux (lm)	lm/W	Flux (lm)	lm/W	Flux (lm)	lm/W
60	34.63	2.08	383	184.3	375	180.3	360	173.1
90*	36.00	3.24	515	159.0	505	155.9	485	149.7
120	37.23	4.47	647	144.7	635	142.1	610	136.5
150	38.42	5.76	778	135.1	765	132.8	735	127.6
180	39.53	7.11	910	128.0	895	125.9	860	121.0
I_F (mA)	V_F (V)	Power (W)	PACJ-7FWL-DC1N		PACJ-7FNL-DC1N		PACJ-7FVL-DC1N	
			Flux (lm)	lm/W	Flux (lm)	lm/W	Flux (lm)	lm/W
60	34.63	2.08	338	162.7	330	158.7	320	153.8
90*	36.00	3.24	455	140.4	445	137.3	430	132.7
120	37.23	4.47	572	127.9	560	125.3	540	120.8
150	38.42	5.76	688	119.5	675	117.2	650	112.8
180	39.53	7.11	805	113.2	790	111.1	760	106.9
I_F (mA)	V_F (V)	Power (W)	PACJ-7FNL-EC1N		PACJ-7FVL-EC1N			
			Flux (lm)	lm/W	Flux (lm)	lm/W		
60	34.63	2.08	292	140.2	283	136.2		
90*	36.00	3.24	390	120.4	380	117.3		
120	37.23	4.47	488	109.2	477	106.6		
150	38.42	5.76	587	101.9	573	99.5		
180	39.53	7.11	685	96.3	670	94.2		

● All values are reference only.

Absolute Maximum Ratings

Parameter	White/Neutral White/Warm White
Max DC Forward Current (mA)	180
Max Voltage at 180mA	42
Peak Pulsed Forward Current (mA)	270 (less than 1/10 duty cycle@1KHz)
ESD Sensitivity (HBM per MIL-STD-883E Method 3015.7)	±2000V
LED Junction Temperature	120°C
Operating Board Temperature at Maximum DC Forward Current	-40°C - 90°C
Storage Temperature	-40°C - 120°C
Reverse Voltage	Not designed to be driven in reverse bias

Color Bin

White Binning Structure Graphical Representation

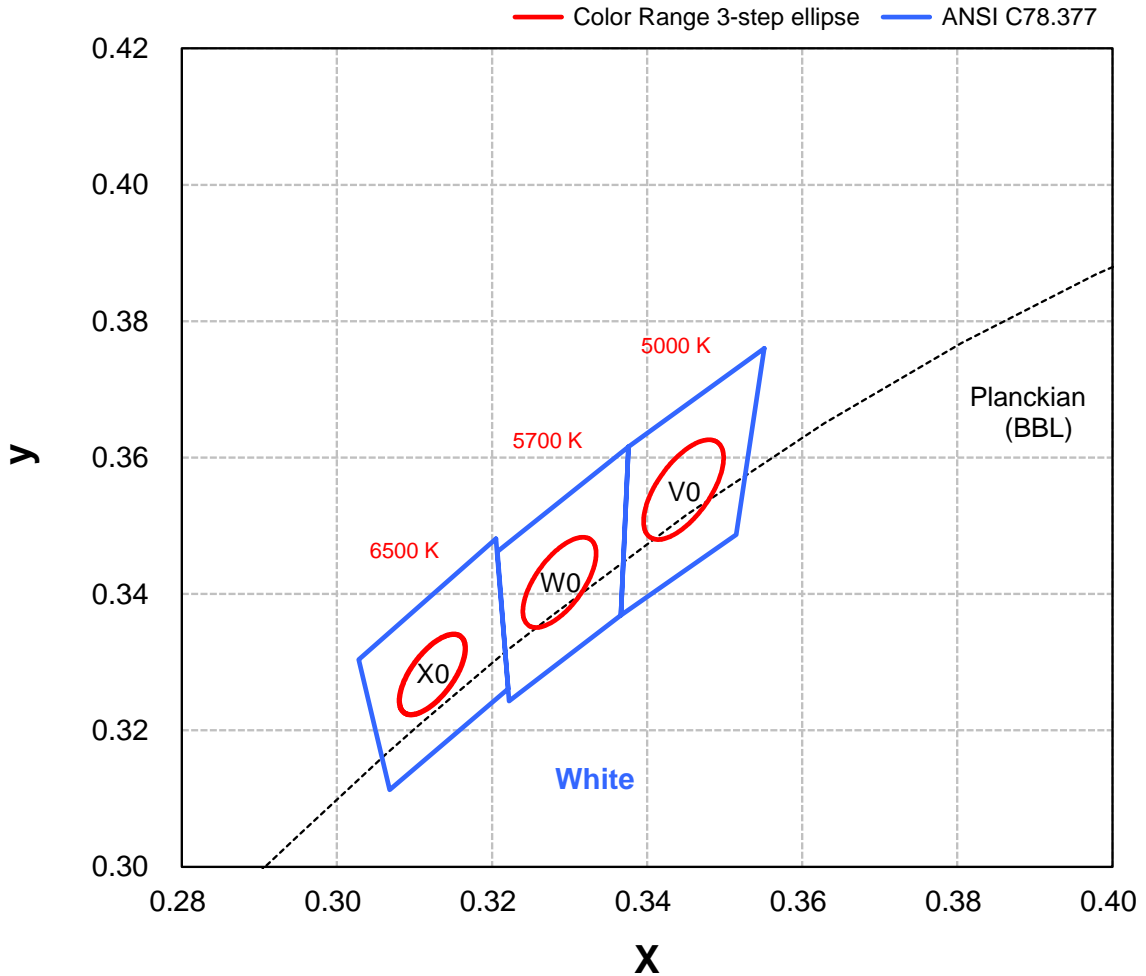

White Bin Structure

Bin Code	Center	Oval parameter	Typ. CCT (K)	Bin Code	Center	Oval parameter	Typ. CCT (K)
V0	x	a	5000	X0	x	a	6500
	y	b			y	B	
		e°				e°	
W0	x	a	5700				
	y	B					
		e°					

- Color range stay within MacAdam “3-step” ellipse from the chromaticity center.
- The chromaticity center refers to ANSI C78.377.
- Tolerance on each color bin (x , y) is ± 0.005

Color Bin

Neutral White Binning Structure Graphical Representation

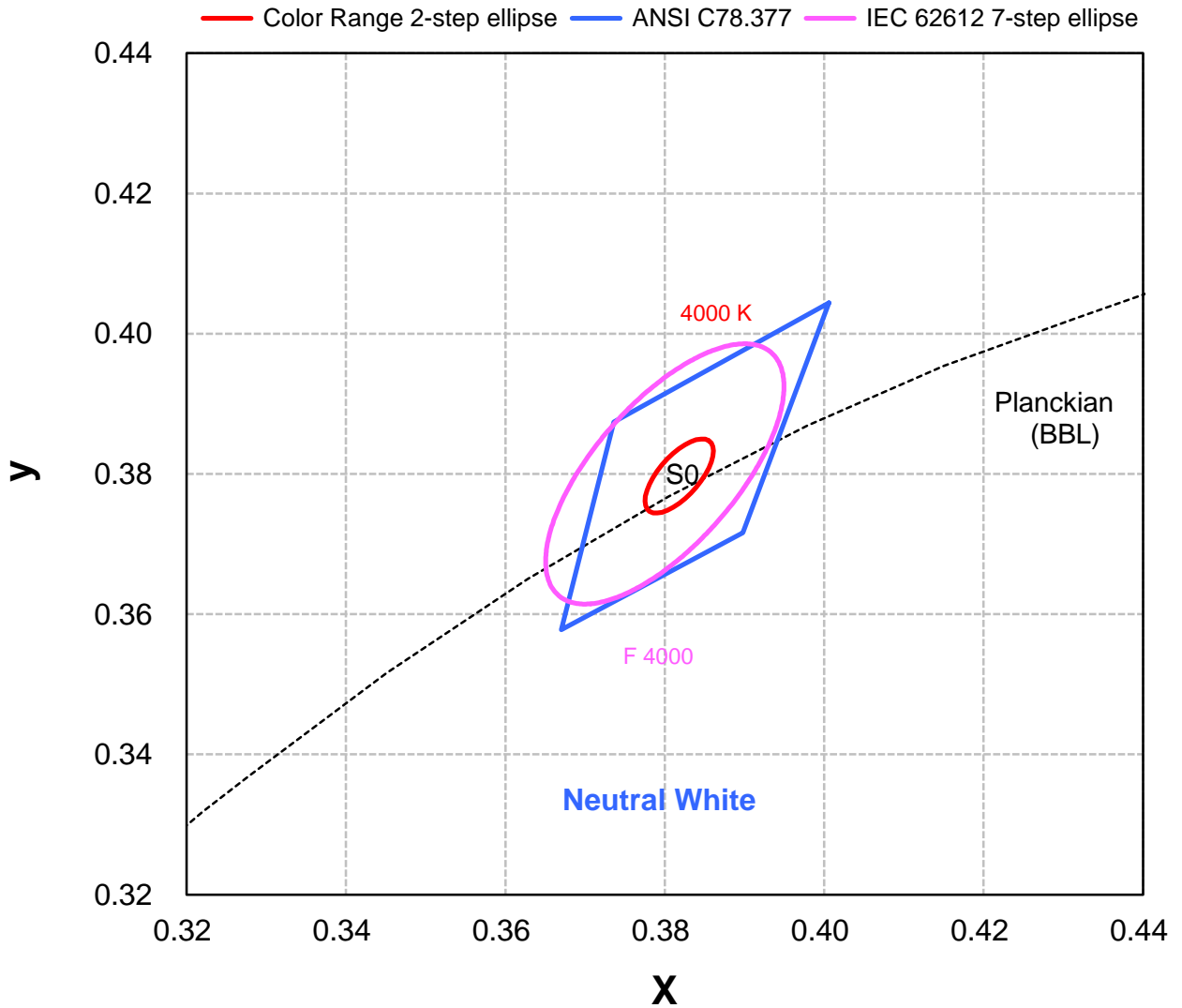

Neutral White Bin Structure

Bin Code	Center	Oval parameter	Typ. CCT (K)
S0	x	0.3818	4000
	y	0.3797	
	a	0.00626	
	b	0.00268	
		e°	53.72

- Color range stay within MacAdam "2-step" ellipse from the chromaticity center.
- The chromaticity center refers to ANSI C78.377.
- Tolerance on each color bin (x , y) is ± 0.005

Color Bin

Warm White Binning Structure Graphical Representation

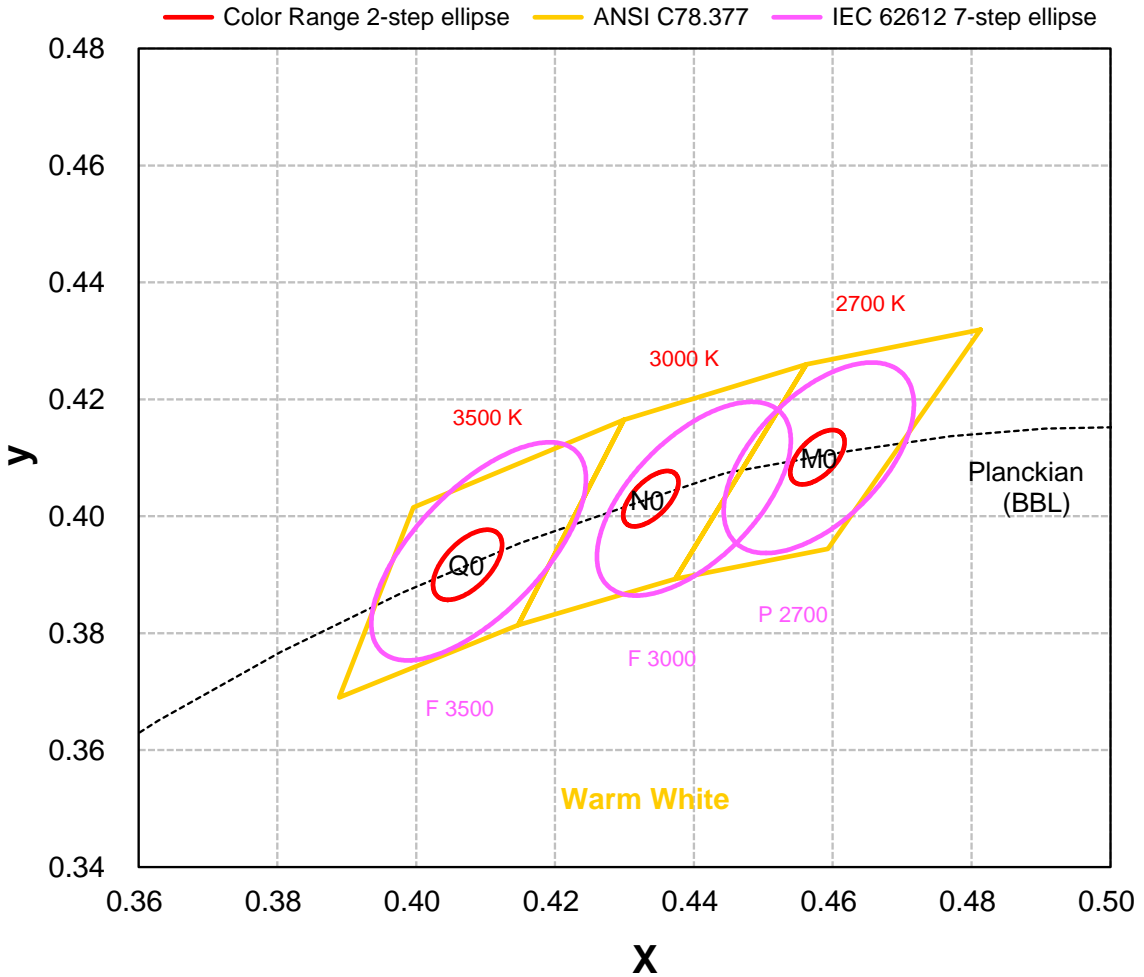

Warm White Bin Structure

Bin Code	Center	Oval parameter	Typ. CCT (K)	Bin Code	Center	Oval parameter	Typ. CCT (K)
M0	x	0.4578	2700	Q0	x	0.4074	3500
	y	0.4101			y	0.3917	
	a	0.0054			a	0.00695	
N0	x	0.4338	3000	Q0	x	0.4074	3500
	y	0.4030			y	0.3917	
	a	0.00556			a	0.00695	
Q0	x	0.4074	3500	M0	x	0.4578	2700
	y	0.3917			y	0.4101	
	b	0.00352			b	0.0028	
		e°	53.70			e°	54.09
		a	0.00556			a	0.0054
		b	0.00272			b	0.0028
		e°	53.22			e°	53.70

- Color range stay within MacAdam “2-step” ellipse from the chromaticity center.
- The chromaticity center refers to ANSI C78.377.
- Tolerance on each color bin (x , y) is ± 0.005

Color Spectrum, $T_c = 25^\circ\text{C}$

1. PACJ-7FWL-AC1N 、 PACJ-7FNL-AC1N 、 PACJ-7FVL-AC1N

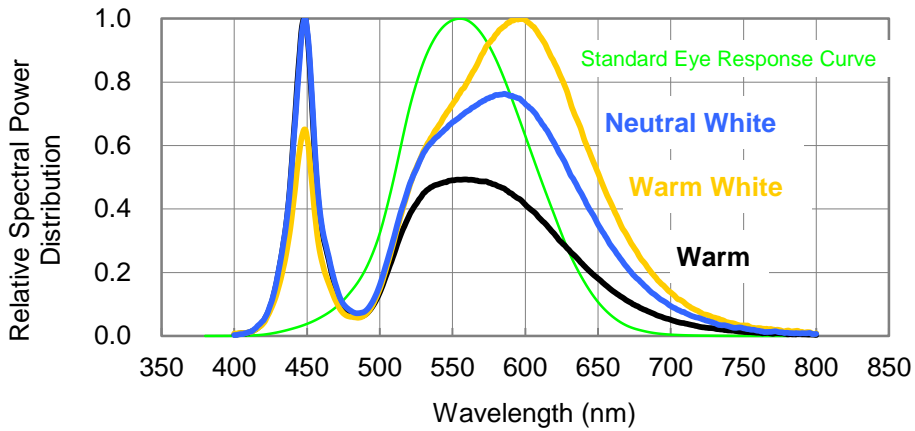

2. PACJ-7FWL-BC1N 、 PACJ-7FNL-BC1N 、 PACJ-7FVL-BC1N

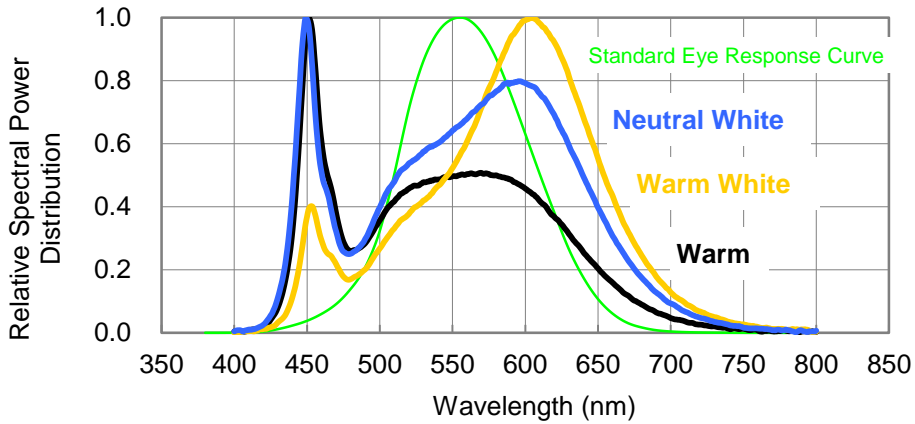

Color Spectrum, $T_c = 25^\circ\text{C}$

3. PACJ-7FWL-DC1N 、 PACJ-7FNL-DC1N 、 PACJ-7FVL-DC1N

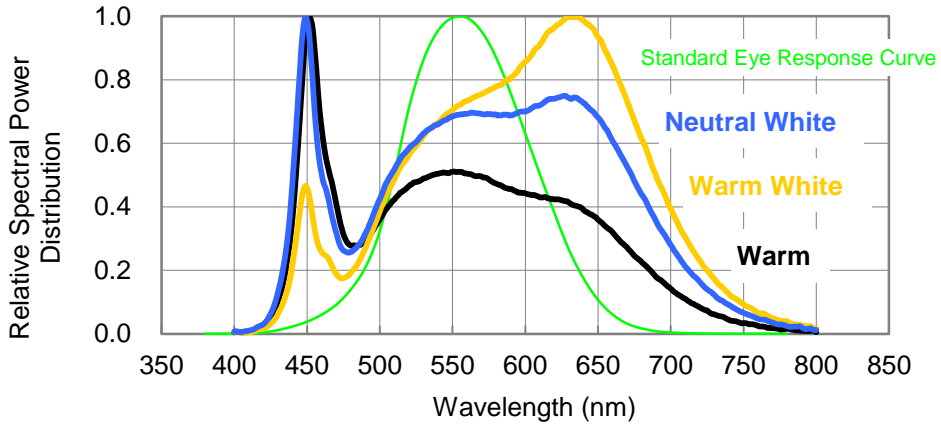

4. PACJ-7FNL-EC1N 、 PACJ-7FVL-EC1N

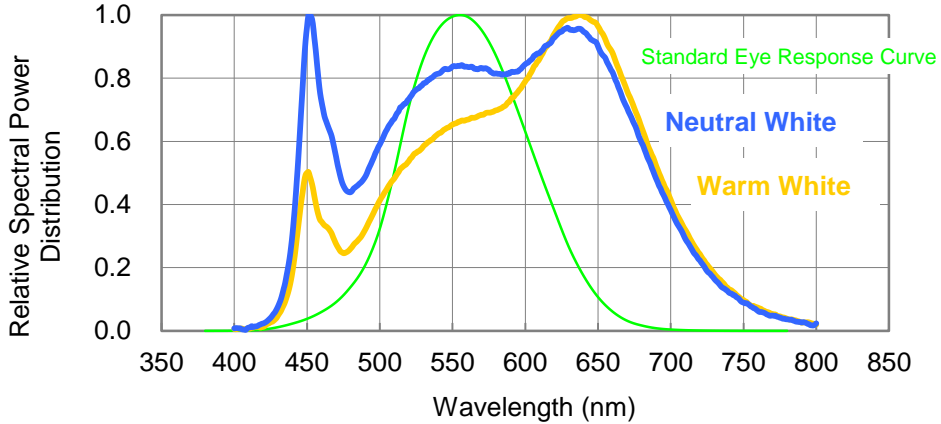

Case Temperature Relative Characteristics

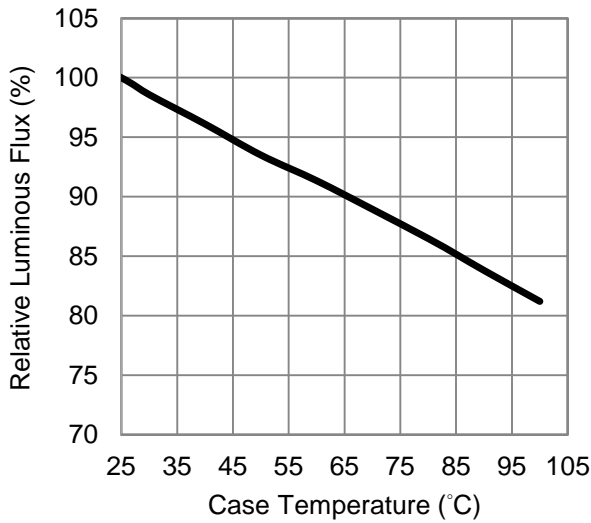

Fig 1. Case Temperature vs. Relative Luminous Flux at 90mA.

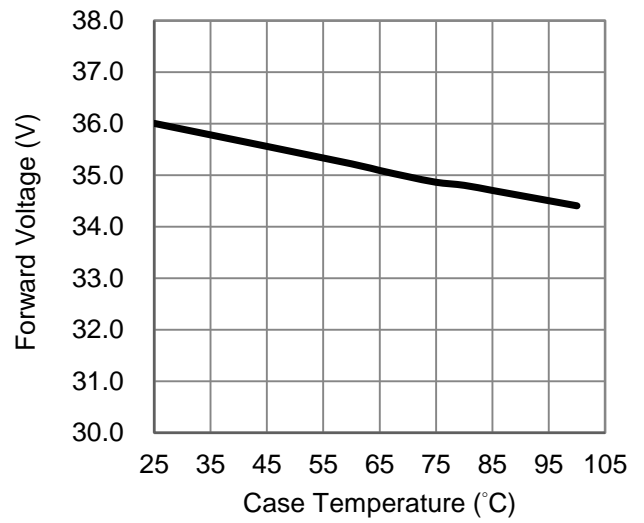

Fig 2. Case Temperature vs. Forward Voltage at 90mA.

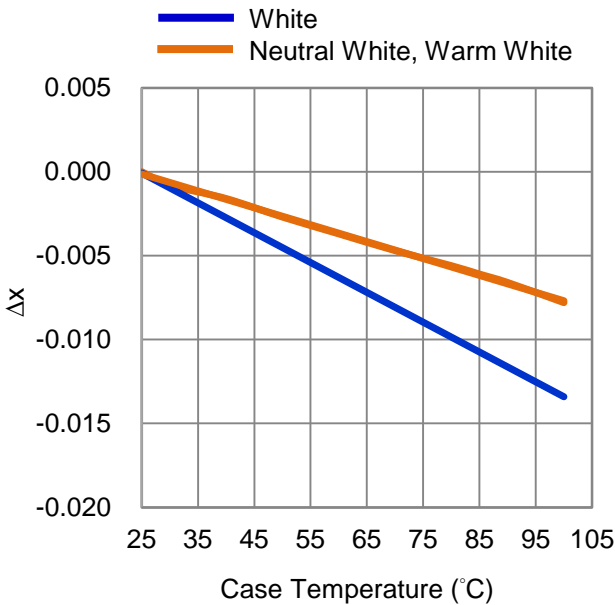

Fig 3. Case Temperature vs. Chromaticity Coordinate Δx at 90mA.

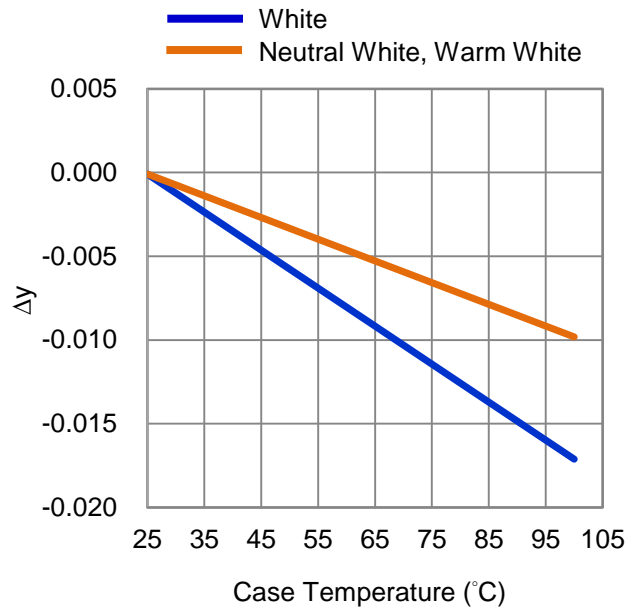

Fig 4. Case Temperature vs. Chromaticity Coordinate Δy at 90mA.

Forward Current Relative Characteristics

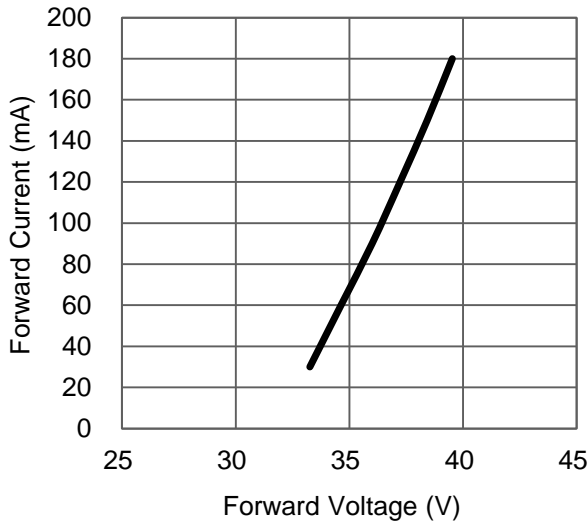

Fig 5. Forward Current vs. Forward Voltage at $T_C=25^\circ\text{C}$.

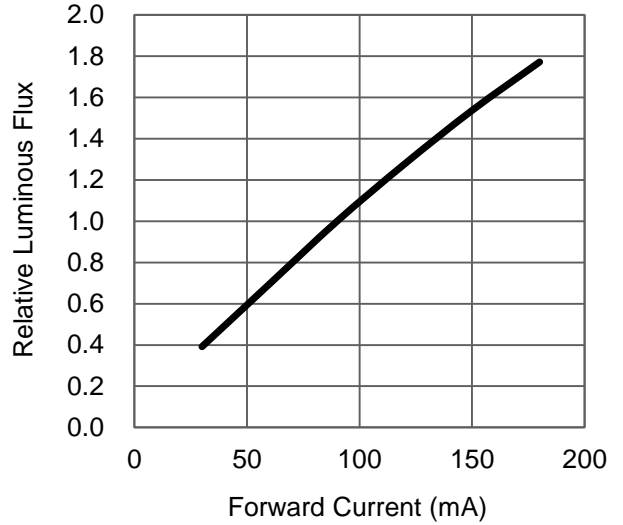

Fig 6. Forward Current vs. Relative Luminous Flux at $T_C=25^\circ\text{C}$.

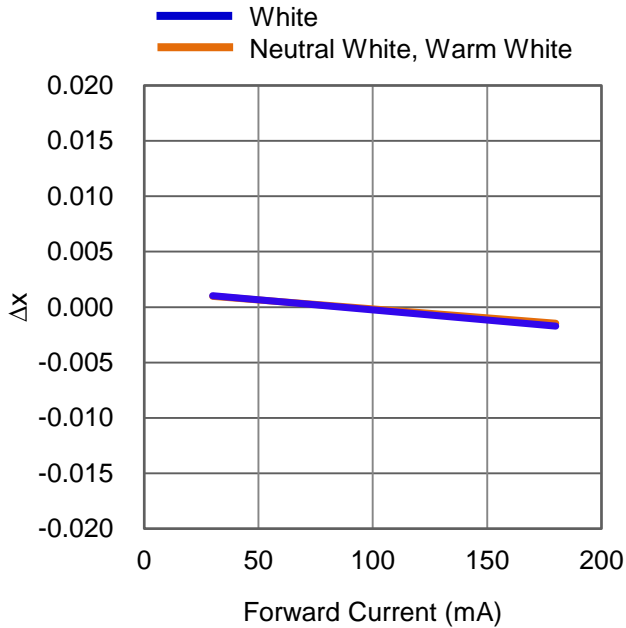

Fig 7. Forward Current vs. Chromaticity Coordinate Δx at $T_C=25^\circ\text{C}$.

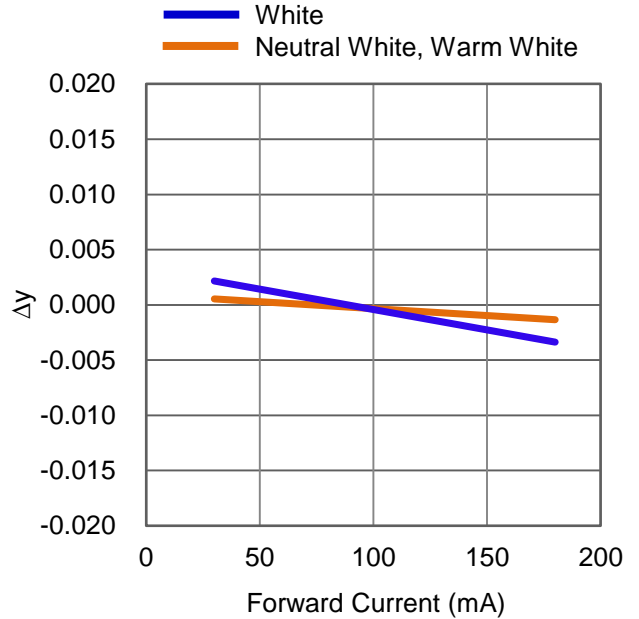

Fig 8. Forward Current vs. Chromaticity Coordinate Δy at $T_C=25^\circ\text{C}$.

Case Temperature vs. Junction Temperature Characteristics

T _c (°C)	T _j (°C)	
	90 (mA)	180 (mA)
0	14	30
5	19	35
10	24	40
15	29	45
20	34	50
25	39	55
30	44	60
35	49	65
40	54	70
45	59	75
50	64	80
55	69	85
60	74	90
65	79	95
70	84	100
75	89	105
80	94	110
85	99	115
90	104	120

Fig 9. Case Temperature vs. Junction Temperature at 90、180mA.

Color Coordinate vs. Forward Current, $T_c = 25^\circ\text{C}$

White Binning Graphical Representation

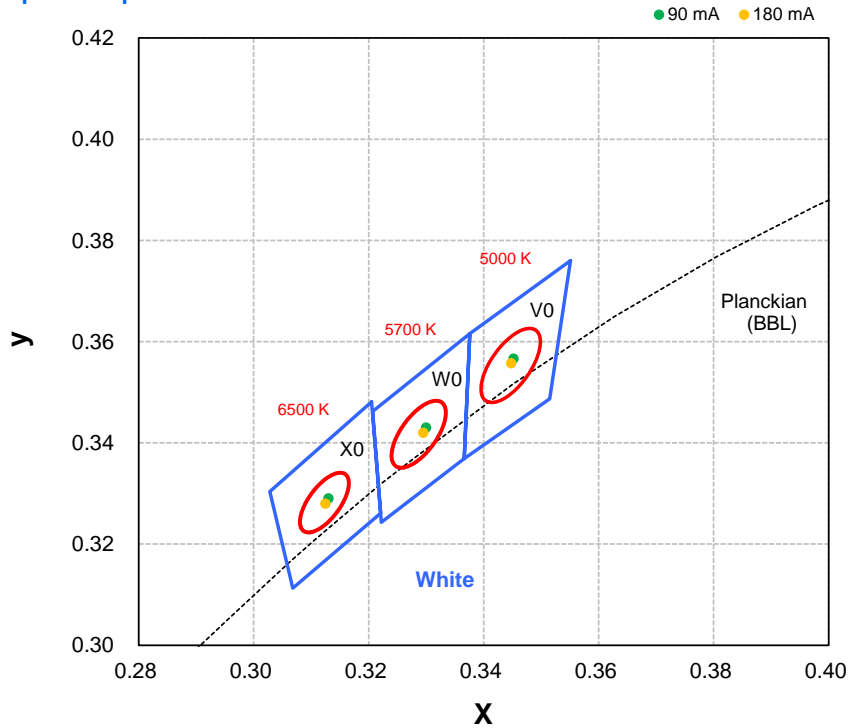

Neutral White Binning Graphical Representation

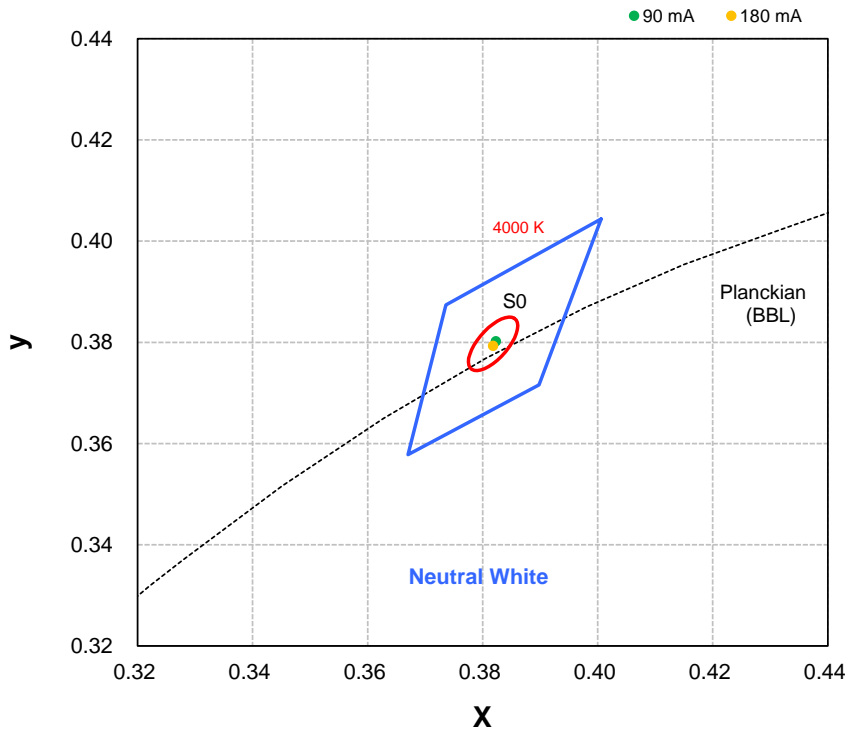

Color Coordinate vs. Forward Current, $T_c = 25^\circ\text{C}$

Warm White Binning Graphical Representation

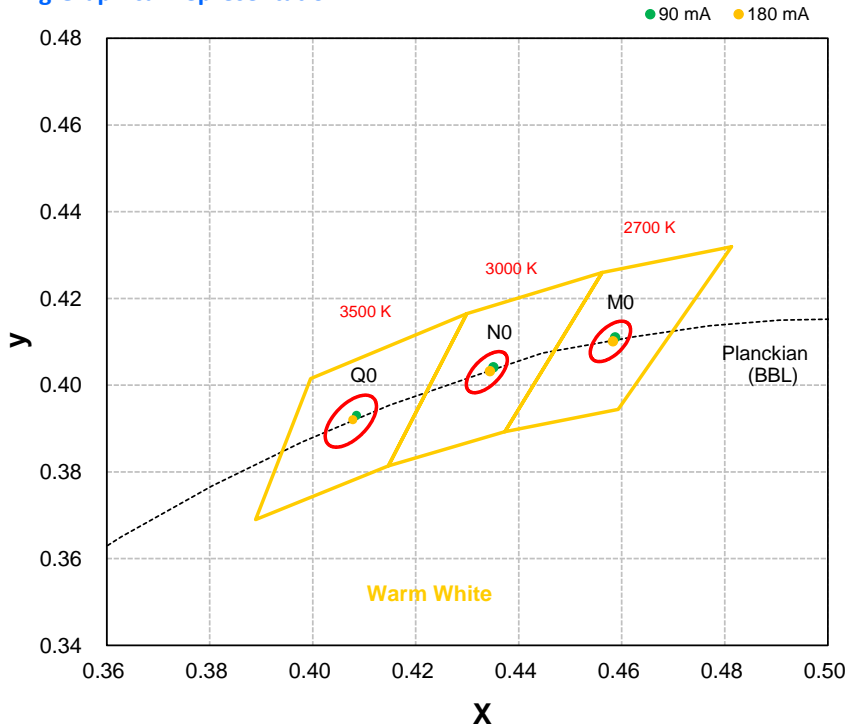

Typical Representative Spatial Radiation Pattern

Lambertian Radiation Pattern

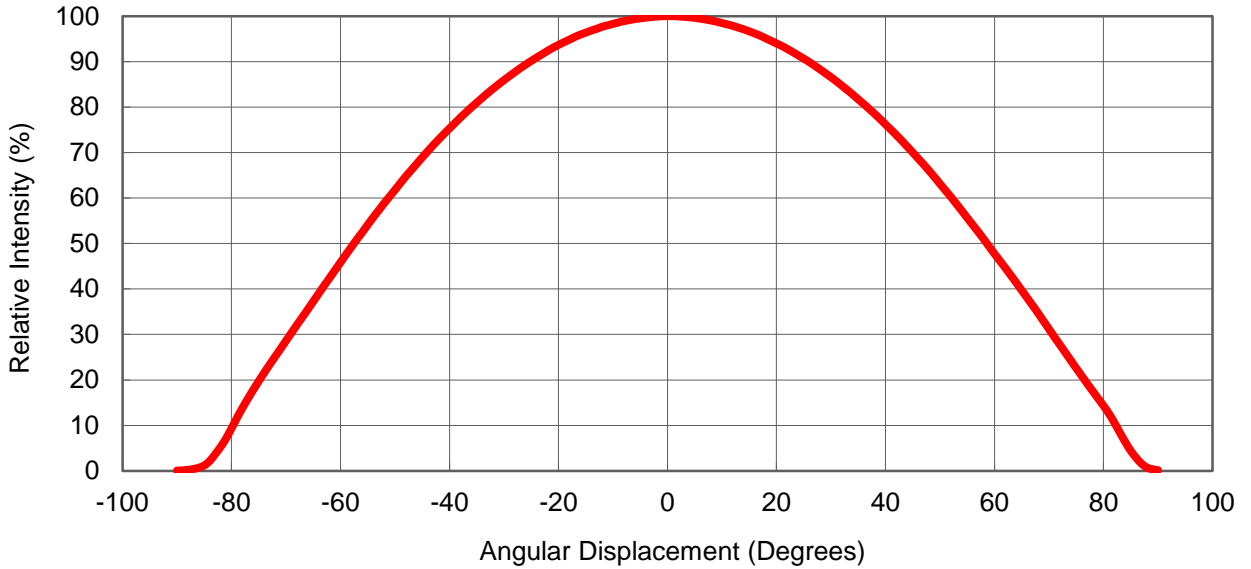

Polar Radiation Pattern

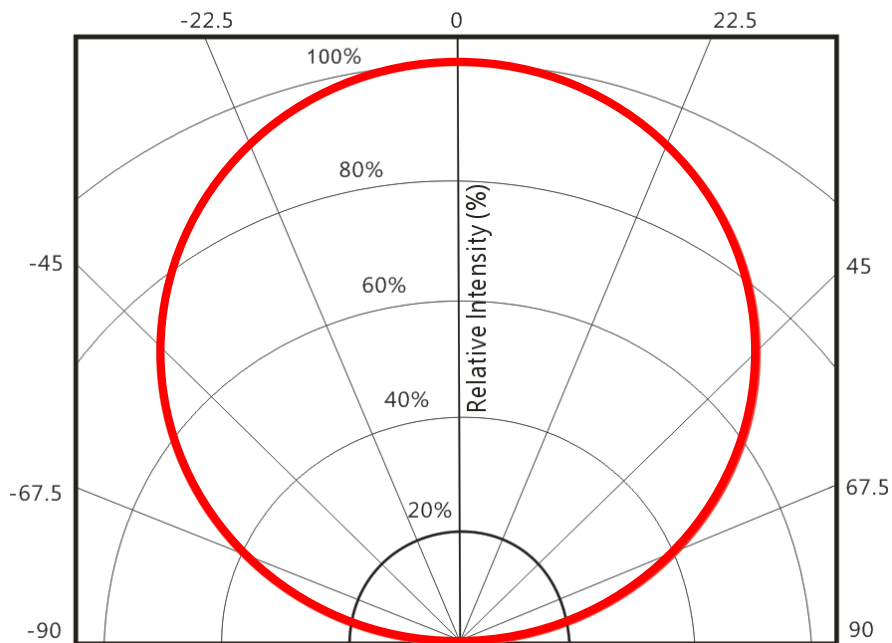

Packing Specifications

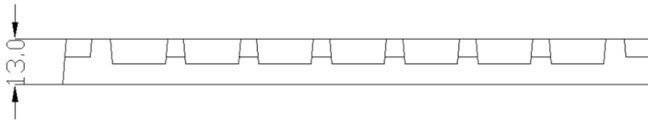
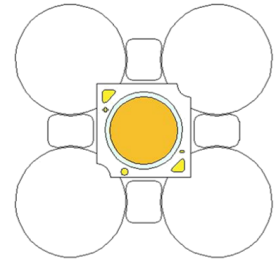
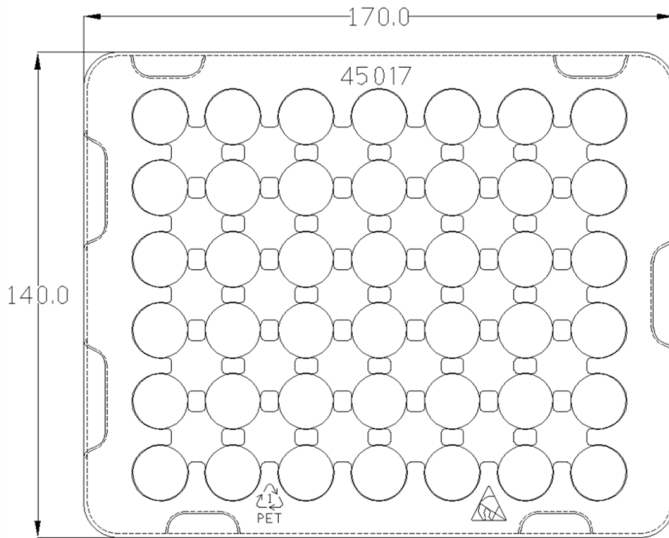

Product 30 pcs/tray

Notes:

1. Drawing not to scale.
2. All dimensions are in millimeters.
3. Unless otherwise indicated, tolerances are $\pm 0.20\text{mm}$.

Assembly note

Regarding the high power density of LED Array, it is strongly recommend to use thermal grease and screws.

In order to reduce thermal resistance at assembly, it is necessary to use TIM (thermal interface Material) uniformly and tighten screws on heatsink, otherwise the bad thermal resistance may cause the packages **burned out**.

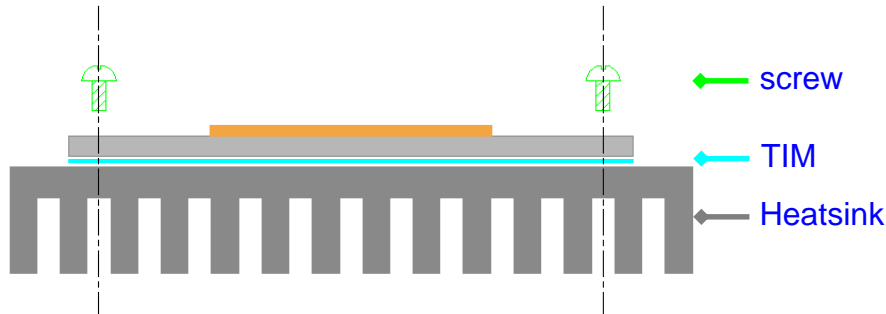

Fig 10. Reference assembly as fixing with screws

Limited Warranty : COB Light Engine Series

This limited warranty is provided by ProLight Opto described below (“Seller”) to you as the original purchaser of the LED lighting product that is identified on Seller’s invoice reflecting its original purchase (the “Product”). We warrant the identification as such on the invoice, will be free of defects in material and workmanship for a period of five (5) YEARS from the date of original purchase. This limited warranty excludes field labor and service charges related to the repair or replacement of the Product. Seller’s aggregate liability with respect to a defective product shall in any event be limited to the monies paid to seller for that defective product. The determination of whether the Product is defective shall be made by Seller in its sole discretion with consideration given to the overall performance of the Product. This limited warranty cannot be transferred to subsequent purchasers of the Product, provided that such Product is resold in new condition and in its original packaging. This limited warranty is void if the product is not used for the purpose for which it is designed.

Recommended Soldering Condition

- Please use lead free and “no clean ” solders.
- Soldering shall be implemented using a soldering tip at a temperature lower than 350 °C, and shall be finished within 3.5 seconds for each pad.
- During the soldering process, put the LEDs on materials whose conductivity is poor enough not to radiate heat of soldering.
- Properly solder tin wires before soldering them to LEDs.
- Avoid touching the silicone lens with the soldering iron.
- Please prevent flux from touching to the silicone lens.
- Please solder evenly on each pad.
- Contacts number of a soldering tip should be within twice for each pad.
- Next process of soldering should be carried out after the LEDs have return to ambient temperature.

*ProLight cannot guarantee if usage exceeds these recommended conditions.

Please use it after sufficient verification is carried out on your own risk if absolutely necessary.

Precaution for Use

- The modules light output are intense enough to cause injury to human eyes if viewed directly. Precautions must be taken to avoid looking directly at the modules with unprotected eyes.
- The modules are sensitive to electrostatic discharge. Appropriate ESD protection measures must be taken when working with the modules. Non-compliance with ESD protection measures may lead to damage or destruction of the product.
- Chemical solvents or cleaning agents must not be used to clean the modules. Mechanical stress on the Emitters must be avoided. It is best to use a soft brush, damp cloth or low-pressure compressed air.
- The products should be stored away from direct light in dry location.
- The appearance, specifications and flux bin of the product may be modified for improvement without notice. Please refer to the below website for the latest datasheets.
<http://www.prolightopto.com/>

Handling of Silicone Lens LEDs

Notes for handling of silicone lens LEDs

- Please do not use a force of over 0.3kgf impact or pressure on the silicone lens, otherwise it will cause a catastrophic failure.
- Avoid touching the silicone lens and the optical area of the COB Array especially by sharp tools such as Tweezers
- Avoid touching the silicone lens especially by sharp tools such as Tweezers.
- Avoid leaving fingerprints on the silicone lens.
- Please store the LEDs away from dusty areas or seal the product against dust.
- Please do not mold over the silicone lens with another resin. (epoxy, urethane, etc)

