

2.4GHZ TRANSMIT / RECEIVE ZIGBEE RFEIC WITH DIVERSITY SWITCH

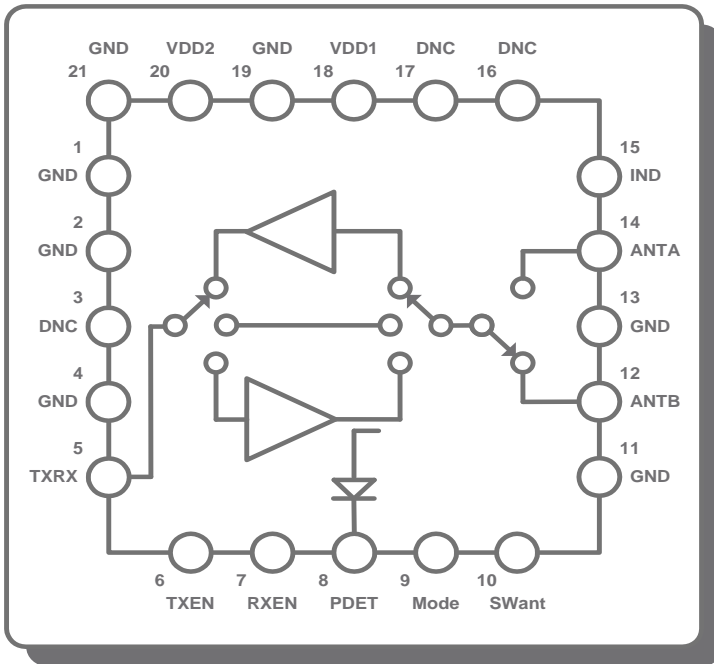

DESCRIPTION

The RFX2411 is a fully integrated, single-chip, single-die RFEIC (RF Front-end Integrated Circuit) which incorporates all the RF functionality needed for wireless ZigBee / smart energy applications. The RFX2411 architecture integrates the PA, LNA, Transmit and Receive switching circuitry, the associated matching network, a harmonic filter and a diversity switch all in a CMOS single-chip device. It also includes a bypass mode to provide maximal level of flexibility for system implementations.

This RFEIC is designed for use in 2.4GHz ISM band and supports the 802.15.4 and ZigBee standard. Typical high power applications include home and industrial automation, smart power, and RF4CE among others. Combining superior performance, high sensitivity and efficiency, low noise, small form factor, and low cost, RFX2411 is the perfect solution for applications requiring extended range and bandwidth. RFX2411 has simple and low-voltage CMOS control logic, and requires minimal external components for system implementation. The PA power detect circuit is also integrated.

FEATURES

- ▶ 2.4GHz ZigBee High Power Single-Chip, Single-Die RF Front-End IC
- ▶ Antenna Diversity Switch
- ▶ 2.4GHz Transmit High Power Amplifier with Low-Pass Harmonic Filter
- ▶ Low Noise Amplifier
- ▶ Transmit/Receive Switch Circuitry
- ▶ High Transmit Signal Linearity Meeting Standards for OQPSK Modulation
- ▶ Integrated Power Detector for Transmit Power Monitor and Control
- ▶ Low Voltage (1.2V) CMOS Control Logic
- ▶ ESD Protection Circuitry on All Ports
- ▶ DC Decoupled RF Ports
- ▶ Internal RF Decoupling on All VDD Bias Pins
- ▶ Low Noise Figure for the Receive Channel

- ▶ Very Low DC Power Consumption
- ▶ Full On-chip Matching and Decoupling Circuitry
- ▶ Minimal External Components Required
- ▶ 50-Ohm Input / Output Matching
- ▶ Market Proven CMOS Technology
- ▶ 3 x 3 x 0.55mm Small Outline QFN-20 Package with Exposed Ground Pad

APPLICATIONS

- ▶ ZigBee Extended Range Devices
- ▶ ZigBee Smart Power
- ▶ RF4CE Remote Control
- ▶ Home and Industrial Automation
- ▶ Custom 2.4GHz Radio Systems
- ▶ Mobile and Battery ZigBee Systems

PIN ASSIGNMENTS:

Pin Number	Pin Name	Description
5	TXRX	RF signal to/from the Transceiver: DC shorted to GND
6	TXEN	CMOS Input to Control TX Enable
7	RXEN	CMOS Input to Control RX Enable
8	PDET	Analog Voltage Proportional to the PA Power Output
9	MODE	CMOS Input to control mode of operation
10	SWant	CMOS Input to select antenna for diversity
12	ANTB	RF Signal from the PA or RF Signal Applied to the LNA; DC Shorted to GND
14	ANTA	RF Signal from the PA or RF Signal Applied to the LNA; DC Shorted to GND
15	IND	Inductor to GND
1, 2, 4, 11, 13, 19	GND	Ground – Must be connected to Ground in the Application Circuit
3, 16, 17	DNC	Reserved – Do Not Connect in the Application Circuit
18	VDD1	Voltage Supply Connection
20	VDD2	Voltage Supply Connection

PIN-OUT DIAGRAM:

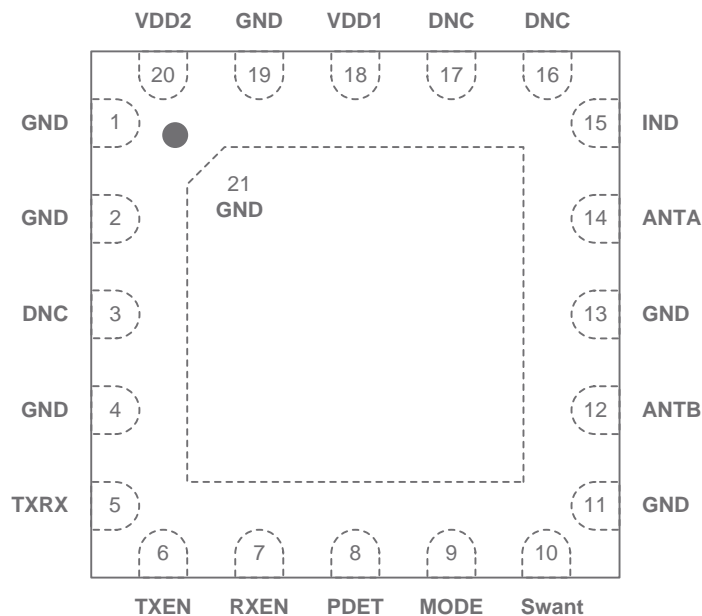

(Top “See-Through” View)

ABSOLUTE MAXIMUM RATINGS:

Parameters	Units	Min	Max	Conditions
DC VDD Voltage Supply	V	0	4.5	All VDD Pins
DC Control Pin Voltage	V	0	4.5	
DC VDD Current Consumption	mA		350	Through VDD Pins when TX is "ON"
TX RF Input Power	dBm		+5	
ANT RF RX Input Power	dBm		+5	
Storage Ambient Temperature	°C	-50	+125	No RF and DC Voltages Applied Appropriate care required according to JEDEC Standards

Note: Sustained operation at or above the Absolute Maximum Ratings for any one or combinations of the above parameters may result in permanent damage to the device and is not recommended.

All Maximum RF Input Power Ratings assume 50-Ohm terminal impedance.

RECOMENDED OPERATING CONDITIONS:

Parameters	Units	Min	Typ	Max	Conditions
DC VDD Voltage Supply (Note 1)	V	2.4	3.3	3.6	All VDD Pins
Control Voltage "High"	V	1.2		VDD	
Control Voltage "Low"	V	0		0.3	
DC Control Pin Current Consumption	µA		1		
DC Shutdown Current	µA		0.1		
PA Turn On/Off Time	µsec			1	
LNA Turn On/Off Time	µsec			1	
Antenna Switch Time	µsec			1	
Operating Ambient Temperature	°C	-40		+85	

Note 1 – For normal operation of the RFX2411, VDD must be continuously applied to all VDD supply pins.

TRANSMIT TECHNICAL PARAMETERS (VDD=3.3V; T=+25 °C)

Parameters	Units	Min	Typ	Max	Conditions
Operating Frequency Band	GHz	2.4		2.5	All RF Pins Terminated by 50 Ohm
Saturated Output Power	dBm		+21		
Output P1dB	dBm		19		Linear Power Mode, CW Input
Small-Signal Gain	dB		24		
Second Harmonic	dBc			-35	P _{OUT} ≤ +20dBm, CW at ANT Pin
Third Harmonic	dBc			-35	P _{OUT} ≤ +20dBm, CW at ANT Pin
Total Supply Current	mA		110		P _{OUT} = +20dBm, Low Current Mode
			115		P _{out} =+20dBm, Linear Power Mode
TX Quiescent Current	mA		17		Low Current Mode
			20		Linear Power Mode
Input Return Loss	dB		-10		
Output Return Loss	dB		-10		
Power Detector Voltage in All Modes	mV	100		800	P _{out} = +5 to +20dBm, 10kΩ load
Input / Output Impedance Single-Ended	Ohm		50		
Load VSWR for Stability (P _{out} =20dBm)	N/A		6:1		All Non-Harmonically Related Spurs Less than -43dBm/MHz
Load VSWR for Ruggedness (P _{out} =20dBm)	N/A		10:1		No Damage

RECEIVE TECHNICAL PARAMETERS (VDD=3.3V; T=+25 °C)

Parameters	Units	Min	Typ	Max	Conditions
Operating Frequency Band	GHz	2.4		2.5	All RF Pins Terminated by 50 Ohm
Gain	dB		12		Low Noise Mode
			10		Low Current Mode
Noise Figure	dB		2.5		Low Noise Mode
			3.5		Low Current Mode
Input P _{1dB}	dBm		-8		Low Noise Mode
			-7		Low Current Mode
RX Quiescent Current	mA		8		Low Noise Mode
			5		Low Current Mode
RF Port Impedance	Ohm		50		At TXRX and ANT Pins
Input Return Loss	dB		-10		At ANT Pin
Output Return Loss	dB		-10		At TXRX Pin

BYPASS MODE TECHNICAL PARAMETERS (VDD=3.3V; T=+25 °C):

Parameters	Units	Min	Typ	Max	Conditions
Operating Frequency	GHz	2.4		2.5	
Insertion Loss	dB		4		
Input P _{1dB}	dBm		10		At ANTA or ANTB pin
Total Current Consumption	mA		0.6		

CONTROL LOGIC TRUTH TABLE

TXEN	RXEN	MODE	Mode of Operation
0	0	0	Shutdown Mode
0	0	1	Bypass Mode
1	X	0	Low Current Transmit Mode
1	X	1	Linear Power Transmit Mode
0	1	0	Low Noise Figure Receive Mode
0	1	1	Low Current Receive Mode

SWant	Mode of Operation
1	ANTA port enabled
0	ANTB port enabled

Note: "1" denotes high voltage state (> 1.2V)
 "0" denotes low voltage stage (<0.3V) at Control Pins
 "X" denotes do not care: either "1" or "0" can be applied

PCB LAND PATTERN

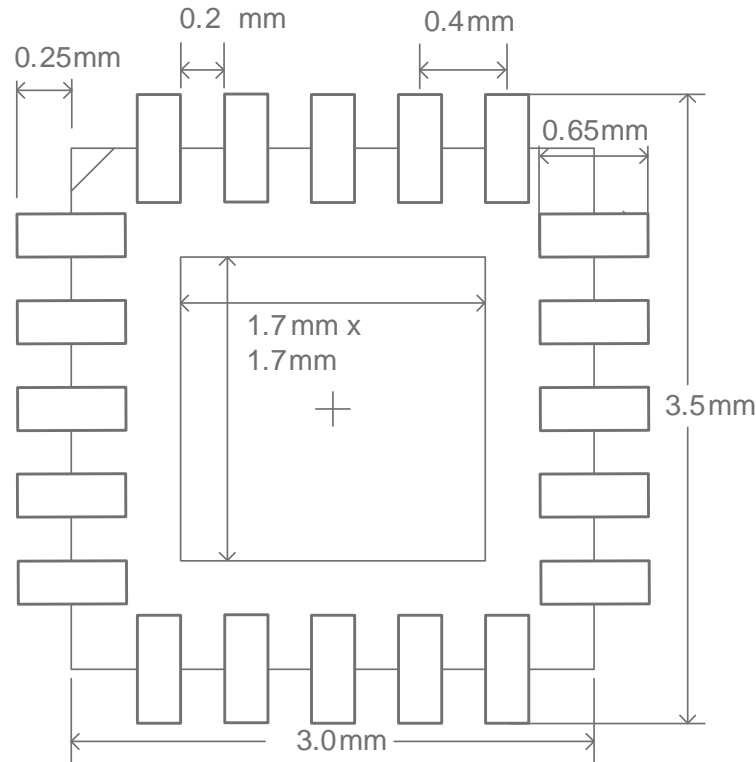

PACKAGE MARKING:

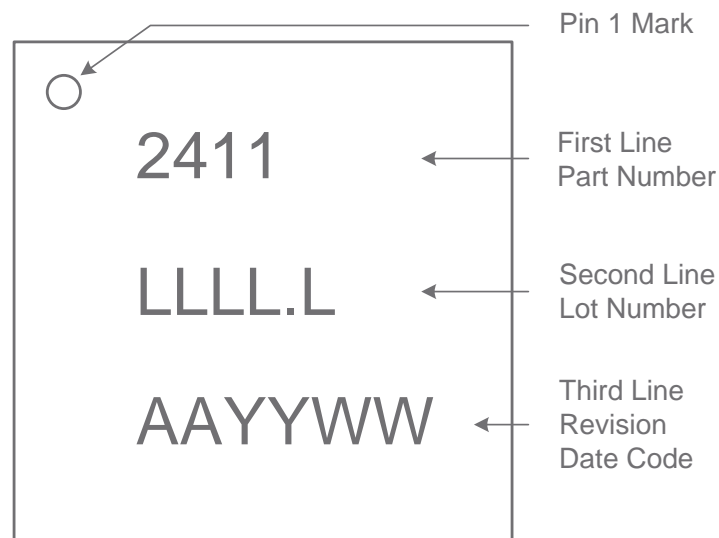

PACKAGE DIMENSIONS:

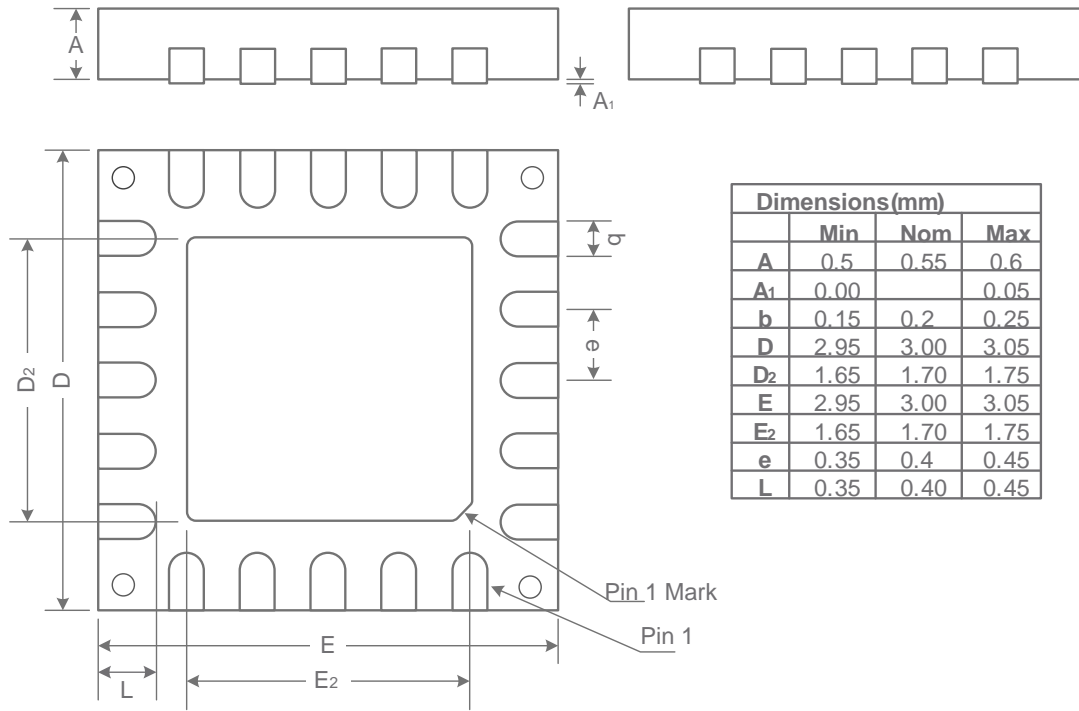

TAPE AND REEL INFORMATION:

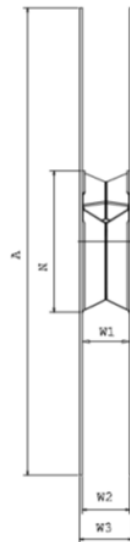
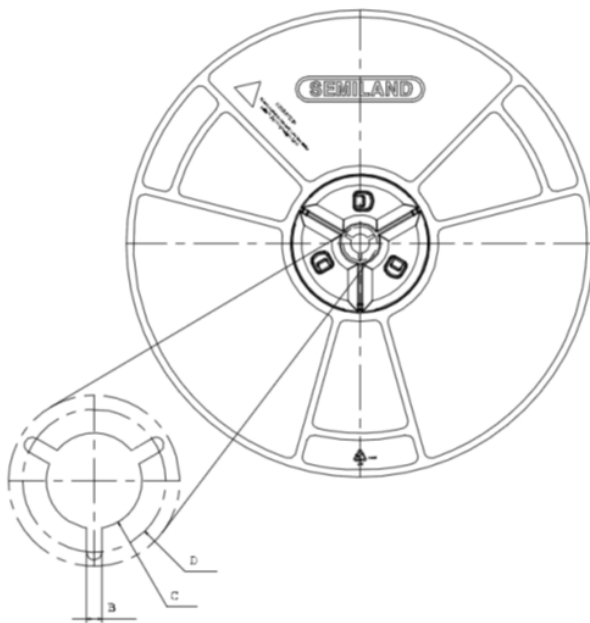
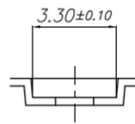
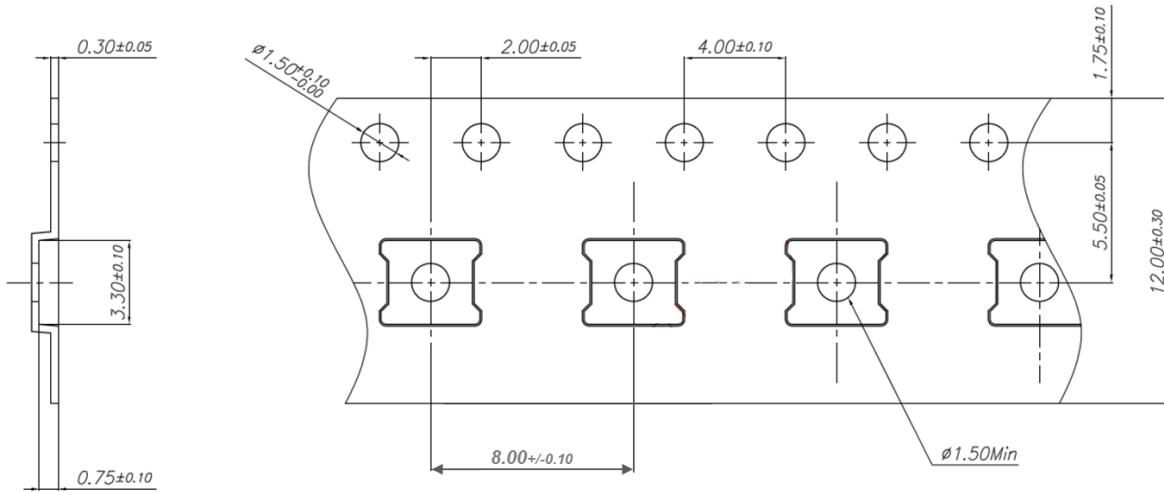

Size	12mm
A	330 ^{+0.2} _{-2.0}
B	1.5min
C	13.0 ^{+0.5} _{-0.2}
D	20.2min
N	100 ^{+2.0} _{-0.0}
W1	12.4 ^{+3.0} _{-0.0}
W2	12.4 ^{+3.0} _{-0.0}
W3	16.4 ^{+2.0} _{-2.0}
PART#	SRL-12134H

RECOMMENDED SOLDER REFLOW PROFILE

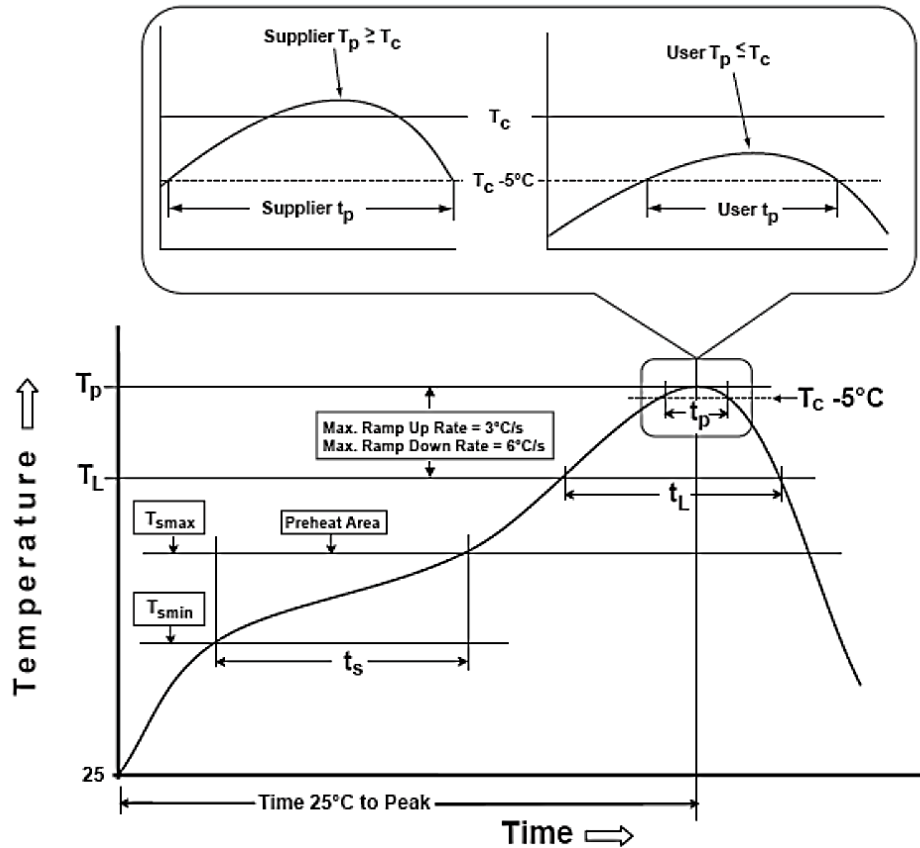

Profile Feature	Sn-Pb Eutectic Assembly	Pb-Free Assembly
Preheat/Soak		
Temperature Min (T_{smin})	100 °C	150 °C
Temperature Max (T_{smax})	150 °C	200 °C
Time (t_s) from (T_{smin} to T_{smax})	60-120 seconds	60-120 seconds
Ramp-up rate (T_L to T_p)	3 °C/second max.	3 °C/second max.
Liquidous temperature (T_L)	183 °C	217 °C
Time (t_L) maintained above T_L	60-150 seconds	60-150 seconds
Peak package body temperature (T_p)	For users T_p must not exceed the Classification temp in Table 4-1. For suppliers T_p must equal or exceed the Classification temp in Table 4-1.	For users T_p must not exceed the Classification temp in Table 4-2. For suppliers T_p must equal or exceed the Classification temp in Table 4-2.
Time (t_p)* within 5 °C of the specified classification temperature (T_c), see Figure 5-1.	20* seconds	30* seconds
Ramp-down rate (T_p to T_L)	6 °C/second max.	6 °C/second max.
Time 25 °C to peak temperature	6 minutes max.	8 minutes max.

* Tolerance for peak profile temperature (T_p) is defined as a supplier minimum and a user maximum.

SnPb Eutectic Process - Classification Temperatures (T_c)

Package Thickness	Volume mm ³ <350	Volume mm ³ ≥350
<2.5 mm	235 °C	220 °C
≥2.5 mm	220 °C	220 °C

Pb-Free Process - Classification Temperatures (T_c)

Package Thickness	Volume mm ³ <350	Volume mm ³ 350 - 2000	Volume mm ³ >2000
<1.6 mm	260 °C	260 °C	260 °C
1.6 mm - 2.5 mm	260 °C	250 °C	245 °C
>2.5 mm	250 °C	245 °C	245 °C