



<b>SPEC NO.</b>	<b>SP03AB15923-0030</b>	<b>ISSUED DATE</b>	<b>2011.08.01</b>	<b>PUBLISHED BY</b>
<b>PRODUCT NAME</b>	<b>PA025AQ0000</b>	<b>VERSION</b>	<b>d01</b>	
		<b>PAGE</b>	<b>2/9</b>	

***CIROCOMM TECHNOLOGY CORP.***

**PART NUMBER : 03A61B600011220**

**1 SCOPE**

This specification covers the dielectric antenna for GPS+GLONASS.

**2 Name of the product**

This product is named "Dielectric Antenna" .

**3 Electrical characteristics**

3-1 Electrical characteristics of antenna

The antenna has the electrical characteristics given in Table 1 under the cirocomm standard installation conditions shown in the figure.

Table 1

No	Parameter	Specification	Notes
1	Range Of Receiving Frequency	GPS : 1575342 ±1.023 MHz GLONASS : 1602±5MHz	
2	Center Frequency	1593MHz ± 3MHz	with 50×50mm GND Plane
3	Bandwidth	34 MHz min	Return Loss ≤ -10dB
4	VSWR	1.5 max	Center Frequency
5	Gain at Zenith	+2.0 dBi typ.	
6	Gain at 10° Elevation	— —	
7	Axial Ratio	— —	
8	Polarization	RHCP	Right Hand Circular Polarization
9	Impedance	50 Ohm	
10	Frequency Temperature Coefficient (τf)	0 ± 20ppm / °C	-40°C to +105°C
11	Operating Temperature		-40°C to +105°C

**4 Environmental conditions**

4-1 Operating conditions

The antenna has the electrical characteristics given in Tables 1 in the temperature range of -40°C to +105°C and under the environmental conditions of +40°C and 0-95% r.h.



<b>SPEC NO.</b>	<b>SP03AB15923-0030</b>	<b>ISSUED DATE</b>	<b>2011.08.01</b>	<b>PUBLISHED BY</b>
<b>PRODUCT NAME</b>	<b>PA025AQ0000</b>	<b>VERSION</b>	<b>d01</b>	
		<b>PAGE</b>	<b>3/9</b>	

#### 4-2 Storage temperature range

The storage temperature range of product is -40°C to +105°C

#### 4-3 Feed pin temperature range

Maximum temperature for soldering of feed pin is +290°C for 3 second.

### 5 Reliability tests

#### 5-1. Low-temperature test

Expose the specimen to -40 °C for 400 hours and then to normal temperature/humidity for 24 hours or more. After this test, examine its appearance and functions.

#### 5-2 High-temperature test

Expose the specimen to +105 °C for 400 hours and then to normal temperature/humidity for 24 hours or more. After this test, examine its appearance and functions.

#### 5-3 High-temperature/high-humidity test

Subject the object to the environmental conditions of +60°C and 90-95% r.h. for 96 hours, then expose to normal temperature/humidity for 24 hours or more. After this test, examine its appearance and functions.

#### 5-4 Thermal shock test

Subject the object to cyclic temperature change (-40°C, 2 hours ↔ +85 °C , 2 hours ) for 100 cycles, the expose to normal temperature/humidity for 24 hours or more.

#### 5-5 Vibration test

##### 5-5-1 Sinusoidal vibration test

Subject the object to vibrations of 5 to 200 to 5Hz swept in 10 minutes, 4.5G at maximum (2mm amplitude), in X and Y directions for two hours each and in Z direction for four hours. After this test, examine its appearance and functions.

##### 5-5-2 Vibration test in packaged condition

Subject the object, which is packaged as illustrated, to vibrations of 15 to 60 to 15Hz swept in 6 minutes, 4G at maximum (2mm amplitude at maximum), applied in X, Y and Z directions for two hours each, i.e. six hours in total. After this test, examine its appearance and functions.

#### 5-6 Free fall test in packaged condition

Drop the object, which is packaged as illustrated, to a concrete surface from the height of 90 cm, on one comer, three edges and six faces once each, i.e. 10 times in total. After this test, examine its appearance and functions.



<b>SPEC NO.</b>	<b>SP03AB15923-0030</b>	<b>ISSUED DATE</b>	<b>2011.08.01</b>	<b>PUBLISHED BY</b>
<b>PRODUCT NAME</b>	<b>PA025AQ0000</b>	<b>VERSION</b>	<b>d01</b>	
		<b>PAGE</b>	<b>4/9</b>	

#### 5-7 Soldering heat resistance test

The lead pins of the unit are soaked in solder bath at  $260 \pm 5^{\circ}\text{C}$  for 10 seconds. After this test, examine its appearance and functions.

#### 5-8 Adhesion test

The device is subjected to be soldered on test PCB. Then apply 0.5Kg (5N) of force for  $5 \pm 1$  seconds in the direction parallel to the substrate. (The soldering should be done by reflow and be conducted with care so that the soldering is uniform and free of defect by stress such as heat shock).

### 6 Inspection

As for the examination during mass production, we place the antenna in the production fixture individually, using the network analyzer to compare its central frequency, bandwidth, and return loss with that of the golden sample.

### 7 Test Record

A Copy of test record filled with following contents shall be provided at time of delivery.

#### 7-1 Quantity of delivery

#### 7-2 Measurement of electrical characteristics :

Following data at normal temperature obtained by the method described in section 18.

#### 7-3 Temperature and humidity of test

Quantity for sampling inspection shall be  $n=5$  for any lot. In case quantity per lot is less than 5, the whole lot shall be inspected.

### 8 Warranty

If any defect occurs from the product during proper use within a year after delivery, it will be repaired or replaced free of charge.

### 9 Other

Any question arising from this specification manual shall be solved by arrangement made by both parties.

### 10 Precautions for use

- Antenna pattern use a silver electrode.
- Please don't use the corrosion gas (sulfur gas, chlorine gas) in the atmosphere.
- Please don't direct solder onto the silver electrode of Antenna pattern.



SPEC NO.	SP03AB15923-0030	ISSUED DATE	2011.08.01	PUBLISHED BY
PRODUCT NAME	PA025AQ0000	VERSION	d01	
		PAGE	5/9	

### 11. Shape and Dimension

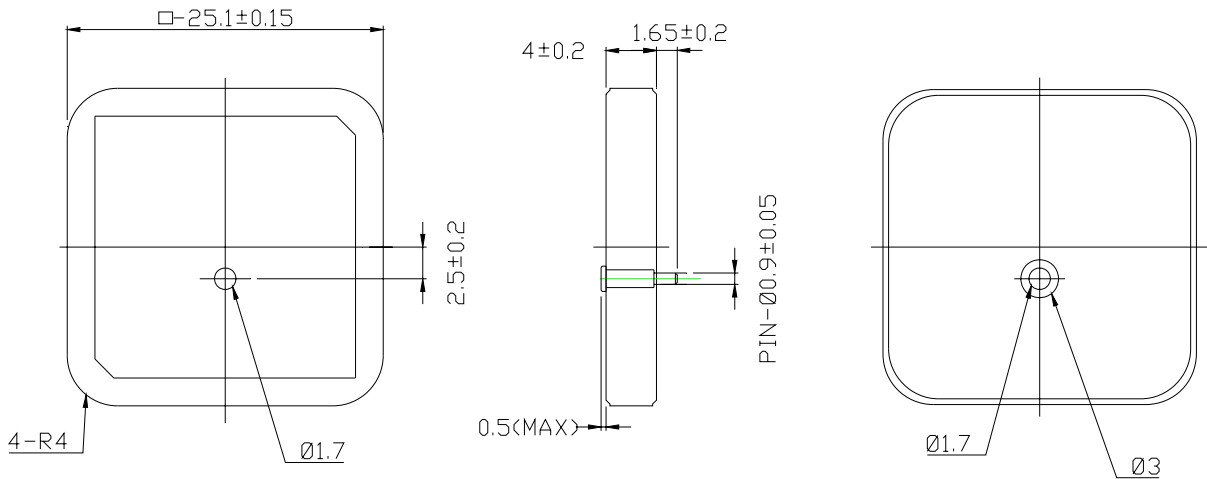

### 12. Typical Electrical Characteristics (T=25°C)

1575.42MHz Typical Return Loss, SWR, Impedance, measured on the test fixture.

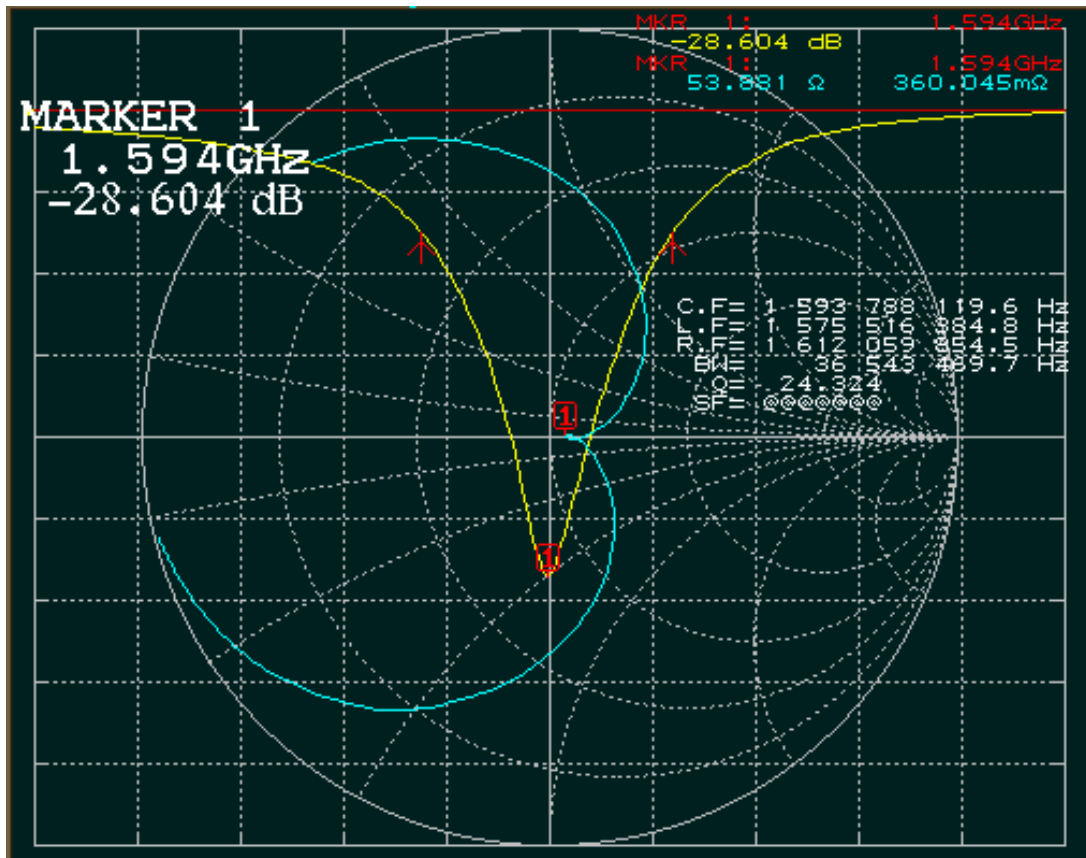

<b>SPEC NO.</b>	<b>SP03AB15923-0030</b>	<b>ISSUED DATE</b>	<b>2011.08.01</b>	<b>PUBLISHED BY</b>
<b>PRODUCT NAME</b>	<b>PA025AQ0000</b>	<b>VERSION</b>	<b>d01</b>	
		<b>PAGE</b>	<b>6/9</b>	

### 13. 2D Radiation Pattern

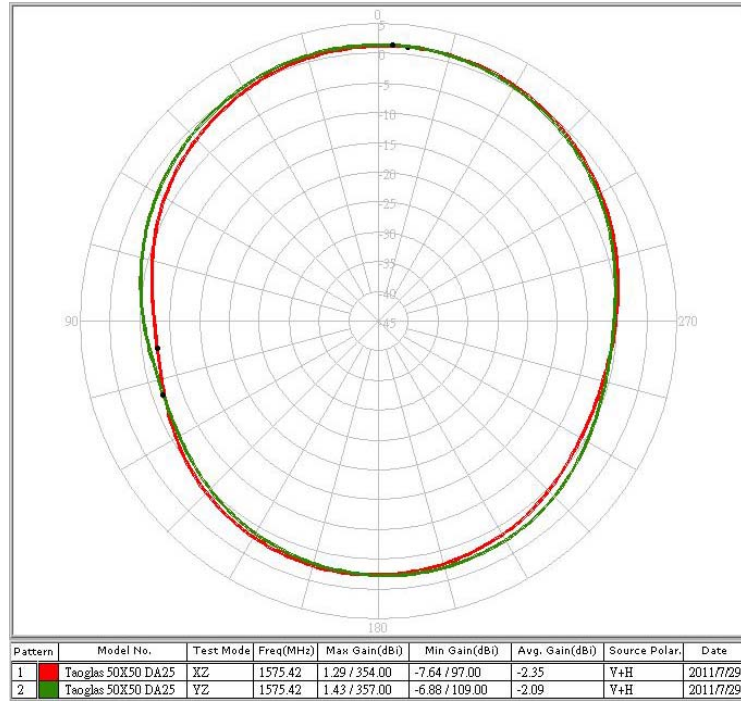

1575.4 MHz XZ+YZ-Plane

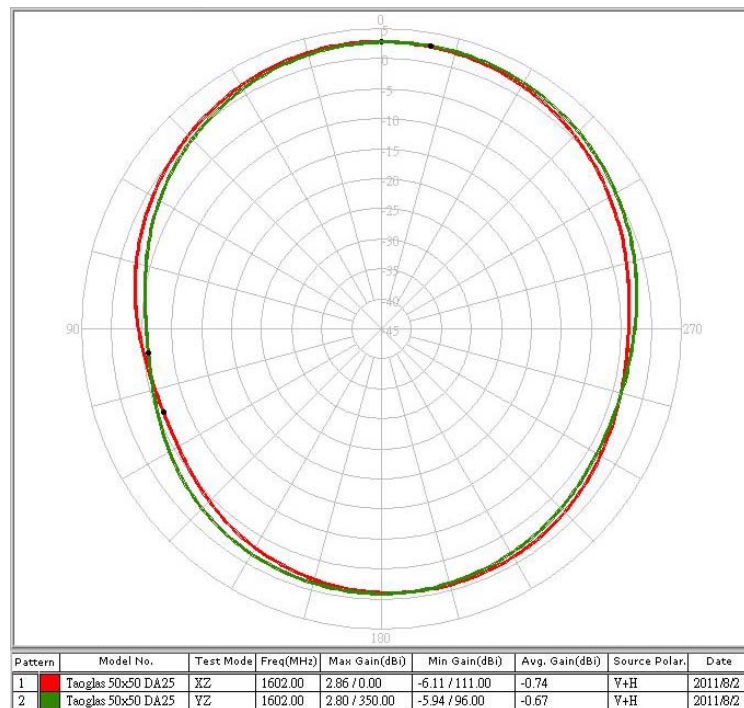

1602.0 MHz XZ+YZ-Plane



<b>SPEC NO.</b>	<b>SP03AB15923-0030</b>	<b>ISSUED DATE</b>	<b>2011.08.01</b>	<b>PUBLISHED BY</b>
<b>PRODUCT NAME</b>	<b>PA025AQ0000</b>	<b>VERSION</b>	<b>d01</b>	
		<b>PAGE</b>	<b>7/9</b>	

### 14. Layout Dimension

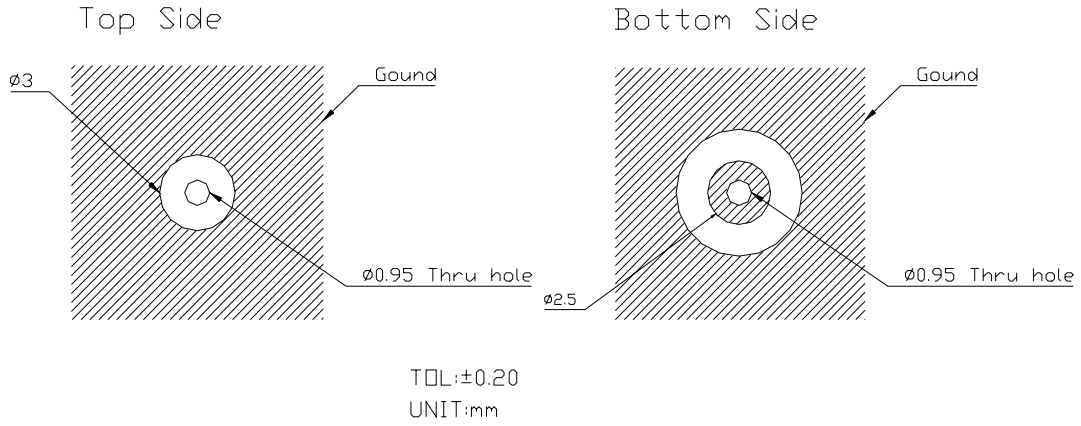

### 15. Tape Dimension

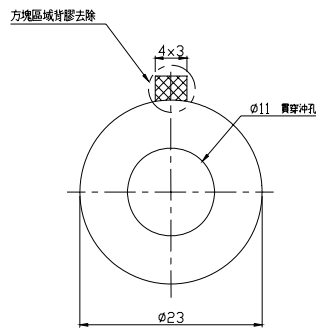

備註: 1. NITTO: NO.5015  
2. Double-coated adhesive tape for industrial use  
3. Thickness: 0.12mm

### 16. Mark

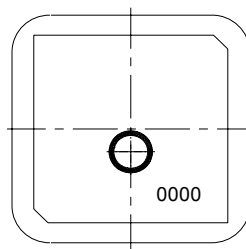

<b>SPEC NO.</b>	<b>SP03AB15923-0030</b>	<b>ISSUED DATE</b>	<b>2011.08.01</b>	<b>PUBLISHED BY</b>
<b>PRODUCT NAME</b>	<b>PA025AQ0000</b>	<b>VERSION</b>	<b>d01</b>	
		<b>PAGE</b>	<b>8/9</b>	

### 17. DA package disassembly

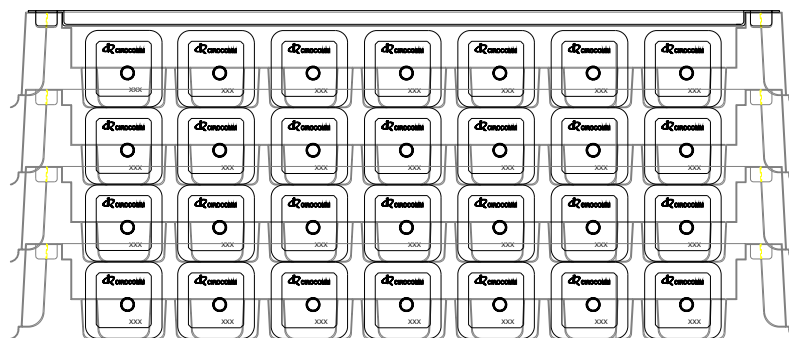
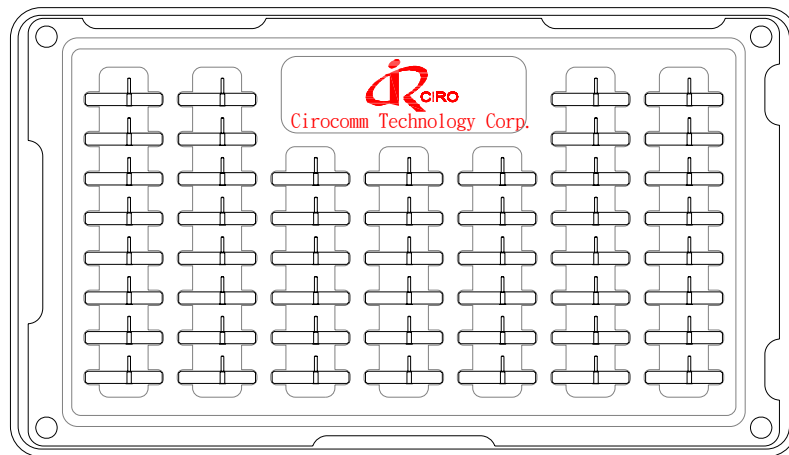



SPEC NO.	SP03AB15923-0030	ISSUED DATE	2011.08.01	PUBLISHED BY
PRODUCT NAME	PA025AQ0000	VERSION	d01	
		PAGE	9/9	

### 18. Packing

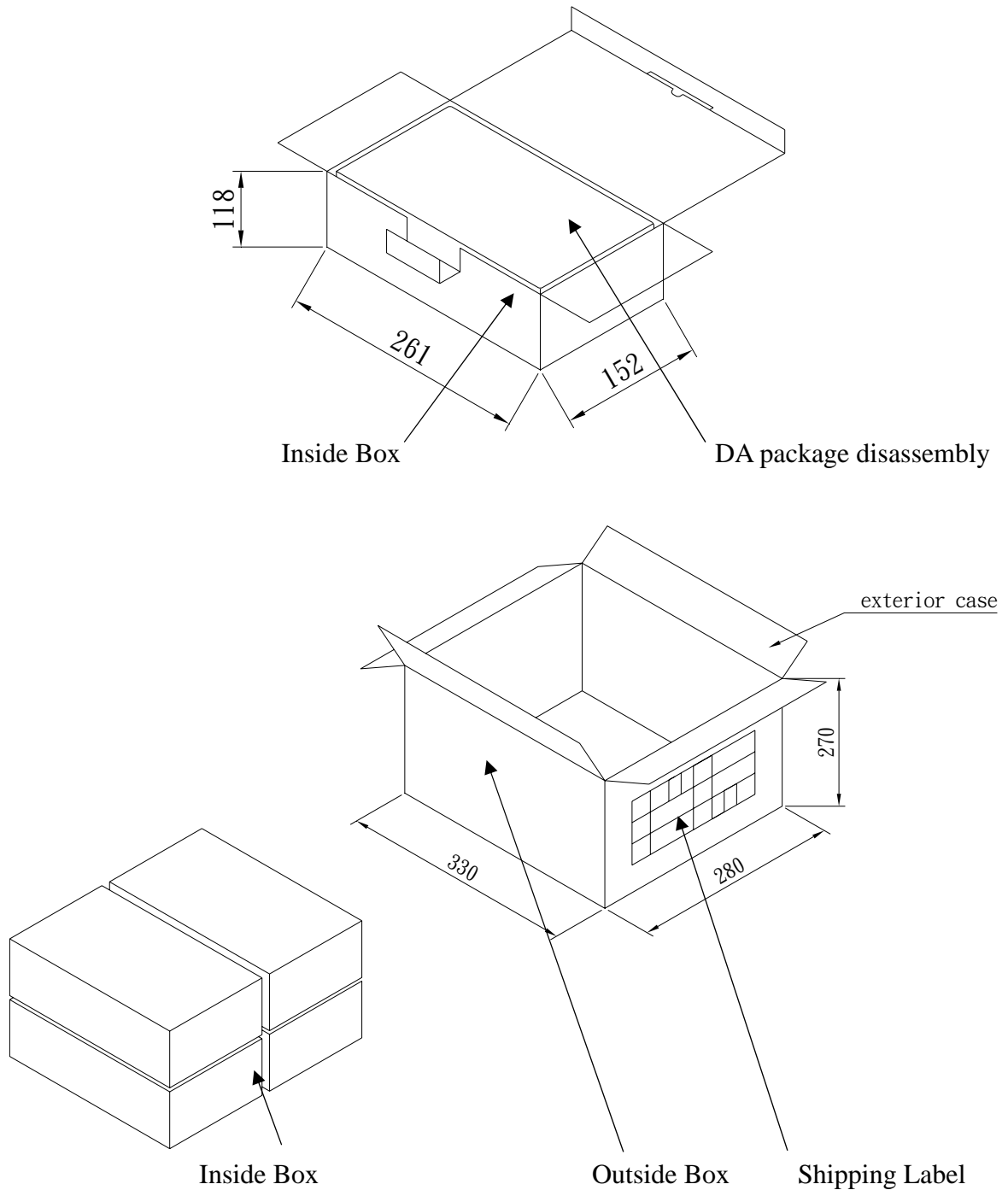

客戶訂單 Cust P/O#	客戶 Cust	太盟料號 CIROCOMM P/N#	批號 LOT#
客戶料號 Cust Item#		品名規格 Item SPEC	
廠商名稱 MANUFACTURER	太盟光電科技股份有限公司 CIROCOMM TECH. CORP.	出貨日期 DELIVERY DATE	數量 QTY.

