



| | | | | |
|--------------|------------------|-------------|------------|---|
| SPEC NO. | SP03AF07005-0010 | ISSUED DATE | 2013.10.30 | P |
| PRODUCT NAME | DPAN0S07 | VERSION | 01 | |
| | | PAGE | 2/13 | |

CIROCOMM TECHNOLOGY .

PART NUMBER: 03A3AE0300J0110

1 SCOPE

This specification covers the dielectric antenna for **700~960MHz, 1710~2170 MHz , 2500~2700 MHz** application.

2 Name of the product

This product is named "Dielectric Antenna".

3 Electrical characteristics

3-1 Electrical characteristics of antenna

The antenna has the electrical characteristics given in Table 1 under the *cirocomm* standard installation conditions shown in the figure of Evaluation Board.

Table 1

| No | Parameter | Specification | |
|----|-----------------------|--|----|
| 1 | Working Frequency | 700~960 MHz,1710~2170 MHz,2500~2700 MHz | |
| 2 | Dimension | 37x5x5 mm | |
| 3 | VSWR | 4.5 max (depends on the special environment) | |
| 4 | Polarization | Linear | |
| 5 | Impedance | 50 Ω | |
| 6 | Operating Temperature | -40~85°C | |
| 7 | Termination | Ag (Environmentally-Friendly Pb Free) | |
| 8 | Efficiency(%) | 700~960 MHz | 55 |
| | | 1710~2170 MHz | 70 |
| | | 2500~2700 MHz | 50 |

* Evaluation board size 45X120 mm

* Actual Electrical value will depend on customer ground plane size





| | | | | |
|--------------|------------------|-------------|------------|---|
| SPEC NO. | SP03AF07005-0010 | ISSUED DATE | 2013.10.30 | P |
| PRODUCT NAME | DPAN0S07 | VERSION | 01 | |
| | | PAGE | 3/13 | |

S11 Response curve

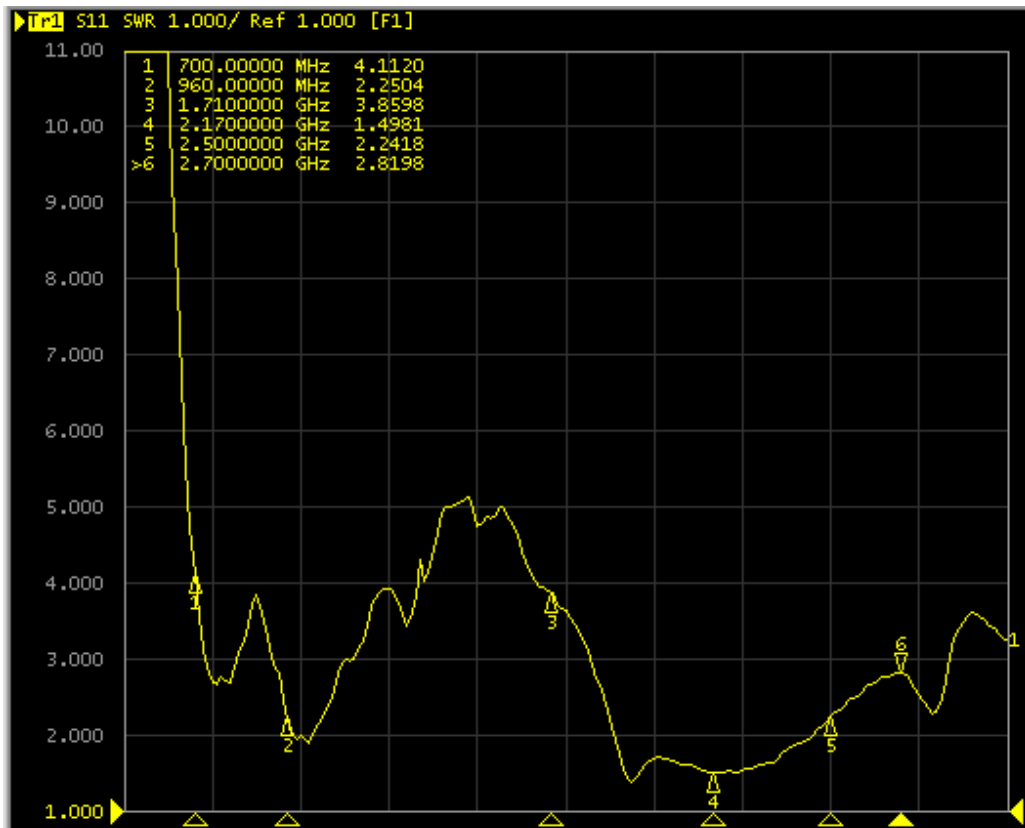
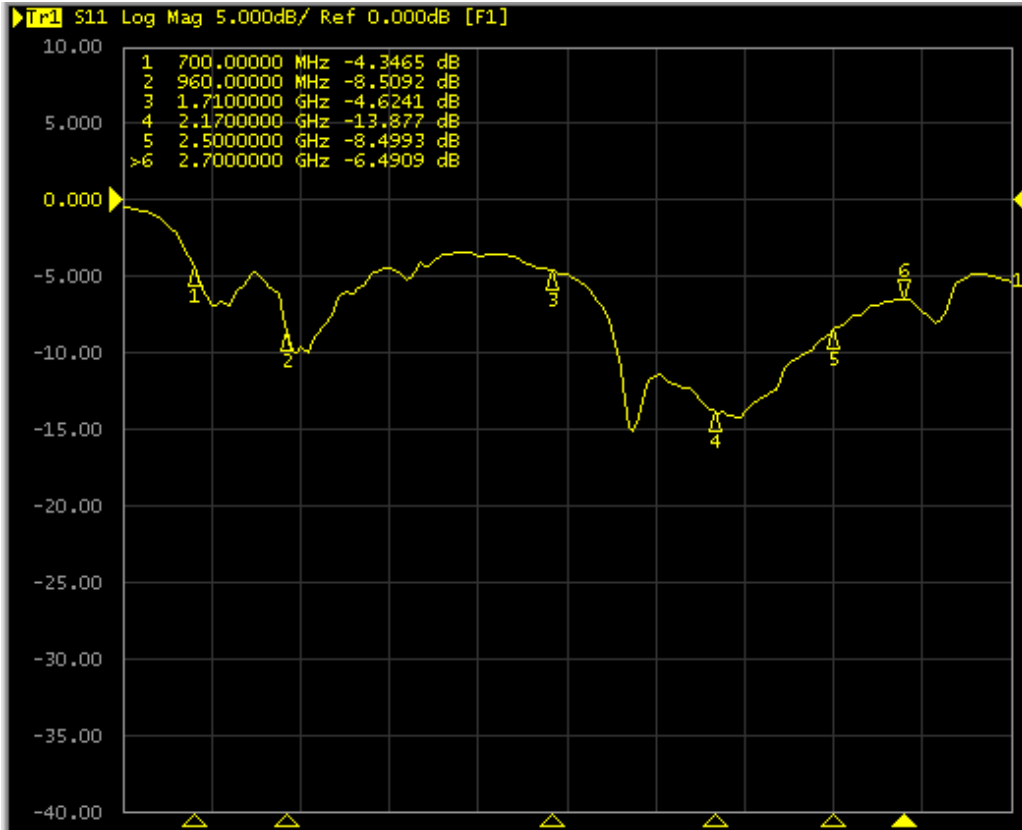



| | | | | |
|--------------|------------------|-------------|------------|---|
| SPEC NO. | SP03AF07005-0010 | ISSUED DATE | 2013.10.30 | P |
| PRODUCT NAME | DPAN0S07 | VERSION | 01 | |
| | | PAGE | 4/13 | |

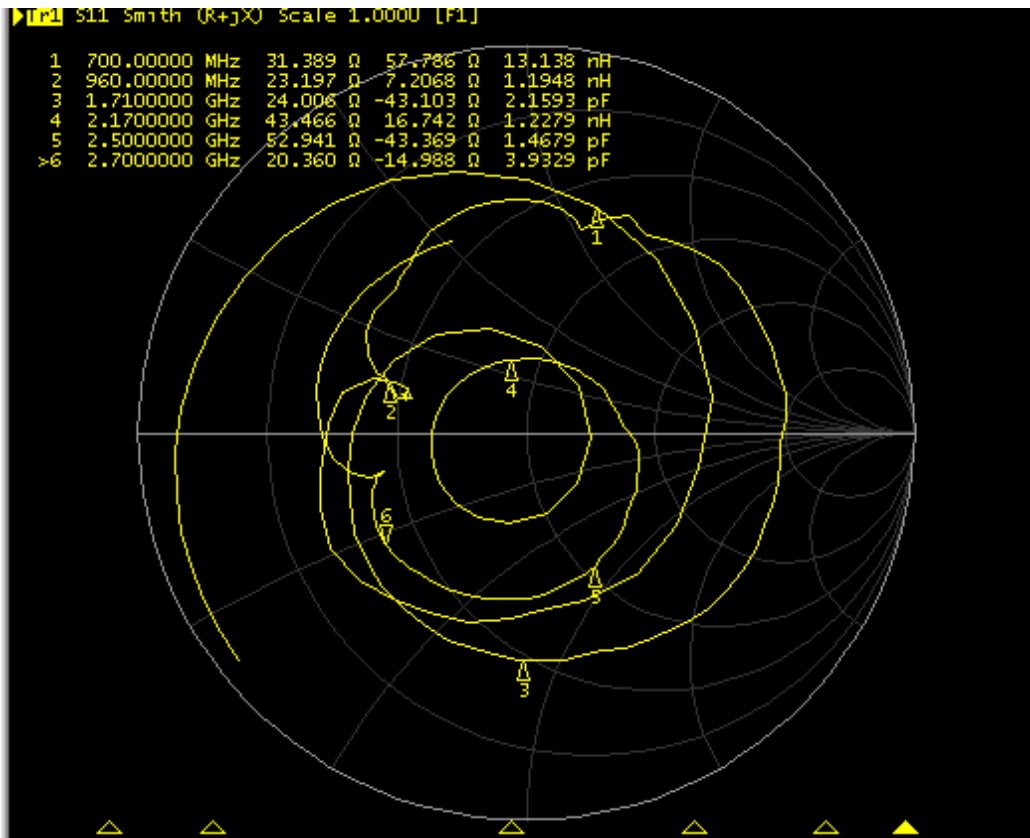



| | | | | |
|---------------------|-------------------------|--------------------|-------------------|----------|
| SPEC NO. | SP03AF07005-0010 | ISSUED DATE | 2013.10.30 | P |
| PRODUCT NAME | DPAN0S07 | VERSION | 01 | |
| | | PAGE | 5/13 | |

Gain and Efficiency

(Ground length: 107mm)

| GSM Antenna parameter Summary | | | | | | | | |
|--------------------------------------|------------|------------|-------------|-------------|-------------|-------------|-------------|-------------|
| Band | 824 | 960 | 1710 | 1850 | 1990 | 2170 | 2500 | 2700 |
| Efficiency (%) | 54.50 | 51.26 | 45.07 | 57.30 | 67.94 | 77.00 | 56.66 | 41.89 |
| Average Gain(dBi) | -2.47 | -2.49 | -3.46 | -2.42 | -1.67 | -1.13 | -2.46 | -3.77 |

Reference efficiency data with different ground plane length:

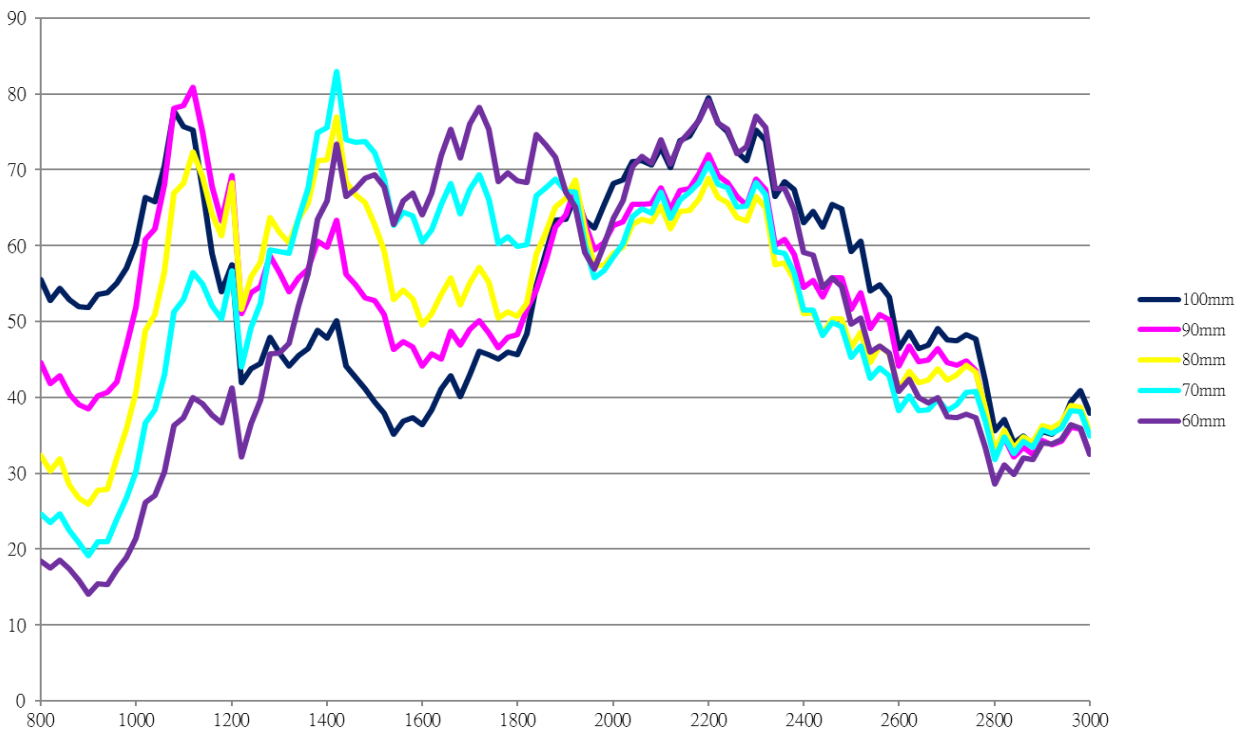

3D Radiation Pattern (measure on CIROCOMM EVB)

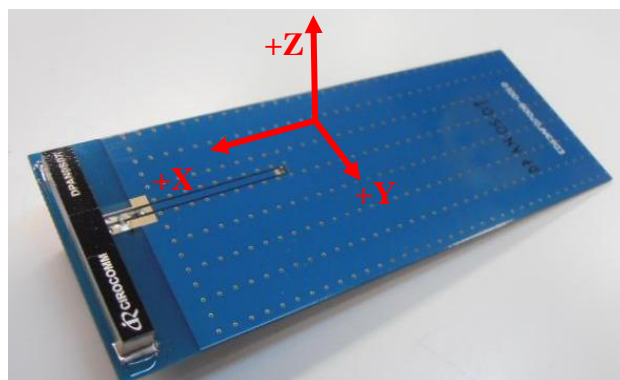



| | | | | |
|--------------|------------------|-------------|------------|---|
| SPEC NO. | SP03AF07005-0010 | ISSUED DATE | 2013.10.30 | P |
| PRODUCT NAME | DPAN0S07 | VERSION | 01 | |
| | | PAGE | 6/13 | |

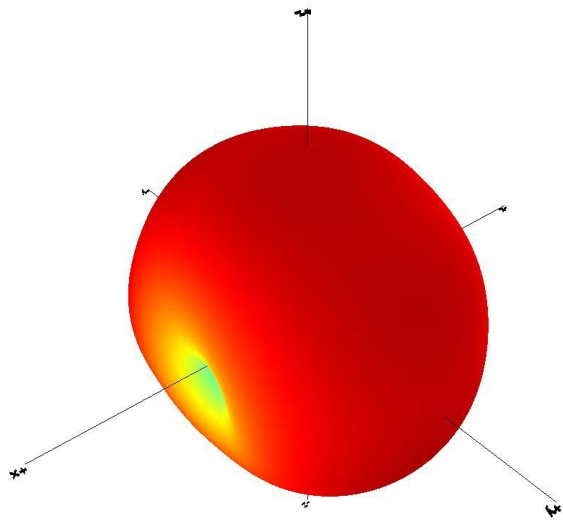

824MHz

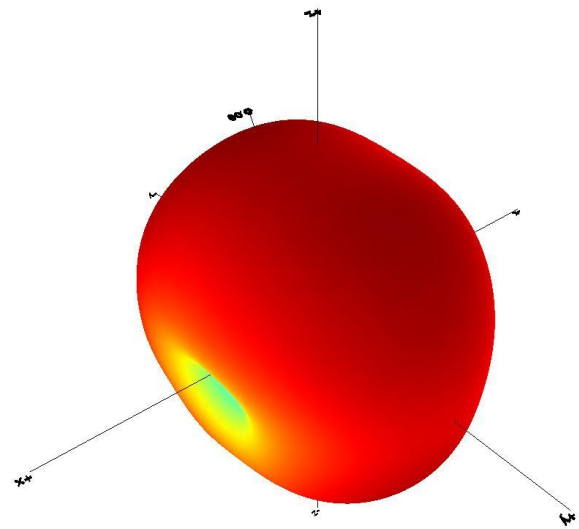

960MHz

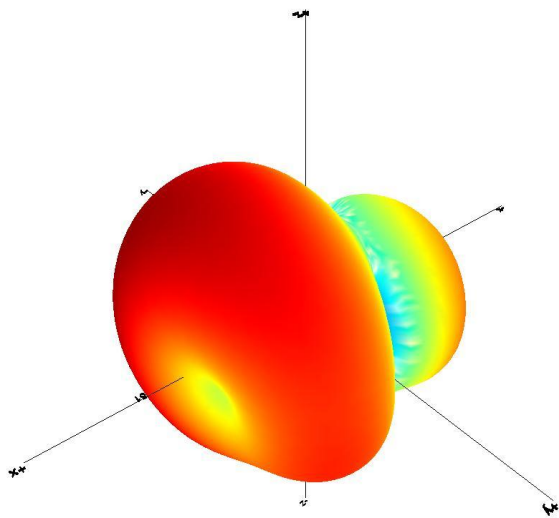

1710MHz

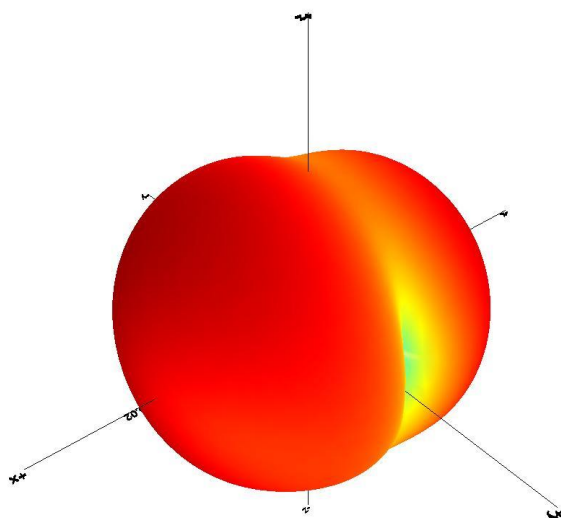

1850MHz

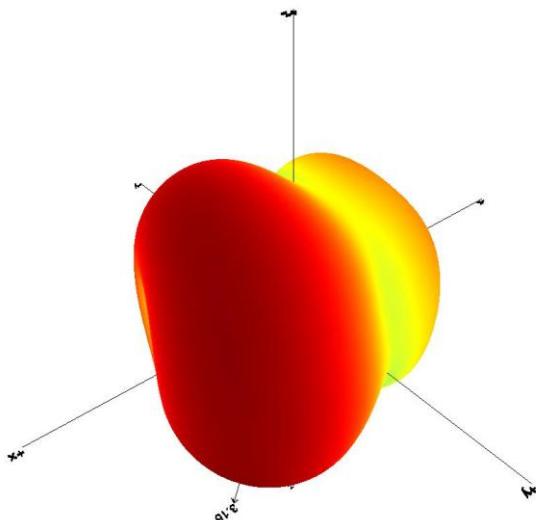

1990MHz

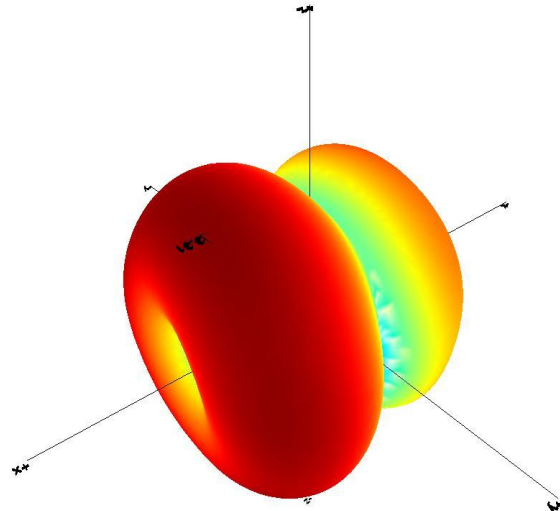

2170MHz





| | | | | |
|--------------|------------------|-------------|------------|---|
| SPEC NO. | SP03AF07005-0010 | ISSUED DATE | 2013.10.30 | P |
| PRODUCT NAME | DPAN0S07 | VERSION | 01 | |
| | | PAGE | 7/13 | |

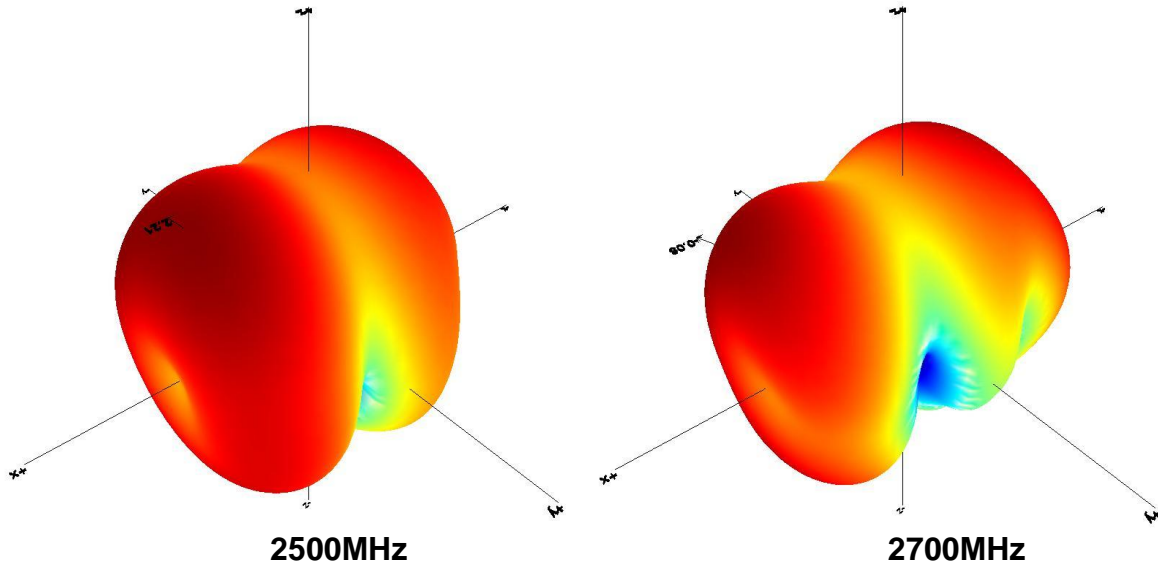

4 Environmental conditions

4-1 Operating conditions

The antenna has the electrical characteristics given in Tables 1 in the temperature range of -40°C to $+85^{\circ}\text{C}$ and under the environmental conditions of $+40^{\circ}\text{C}$ and 0-95% r.h..

4-2 Storage temperature range

The storage temperature range of product is -40°C to $+85^{\circ}\text{C}$

5 Reliability tests

5-1. Low-temperature test

Expose the specimen to -30°C for 500 hours and then to normal temperature/humidity for 24 hours or more. After this test, examine its appearance and functions.

5-2 High-temperature test

Expose the specimen to $+85^{\circ}\text{C}$ for 500 hours and then to normal temperature/humidity for 24 hours or more. After this test, examine its appearance and functions.

5-3 High-temperature/high-humidity test

Subject the object to the environmental conditions of $+85^{\circ}\text{C}$ and 90-95% r.h. for 96 hours, then expose to normal temperature/humidity for 24 hours or more. After this test, examine its appearance and functions.

5-4 Thermal shock test

Subject the object to cyclic temperature change (-30°C , 30 minutes \leftrightarrow $+85^{\circ}\text{C}$, 30 minutes) for 5 cycles, then expose to normal temperature/humidity for 24 hours or more.

5-5 Vibration test

5-5-1 Sinusoidal vibration test

Subject the object to vibrations of 5 to 200 to 5Hz swept in 10 minutes, 4.5G at maximum (2mm amplitude), in X and Y directions for two hours each and in





| | | | | |
|---------------------|-------------------------|--------------------|-------------------|---------------------|
| SPEC NO. | SP03AF07005-0010 | ISSUED DATE | 2013.10.30 | P |
| PRODUCT NAME | DPAN0S07 | VERSION | 01 | 2013.11.01 文件管制章 |
| | | PAGE | 8/13 | |

Z direction for four hours. After this test, examine its appearance functions.

5-5-2 Vibration test in packaged condition

Subject the object, which is packaged as illustrated, to vibrations of 15 to 60 to 15Hz swept in 6 minutes, 4G at maximum (2mm amplitude at maximum), applied in X, Y and Z directions for two hours each, i.e. six hours in total. After this test, examine its appearance and functions.

5-6 Free fall test in packaged condition

Drop the object, which is packaged as illustrated, to a concrete surface from the height of 90 cm, on one corner, three edges and six faces once each, i.e. 10 times in total. After this, check the appearance and functions.

5-7. Soldering Heat Resistance Test:

After the lead pins of the unit are soaked in solder bath at $270 \pm 5^{\circ}\text{C}$ for 10 ± 0.5 seconds and then be left for more than 1 hour at $25 \pm 5^{\circ}\text{C}$ in less than 65% relative humidity.

5-8. Adhesion Test:

The device is subjected to be soldered on test PCB. Then apply 0.5Kg (5N) of force for 10 ± 1 seconds in the direction of parallel to the substrate. (the soldering should be done by reflow and be conducted with care so that the soldering is uniform and free of defect by stress such as heat shock) .

6 Inspection

As for the examination in the mass production, the receiving character of the ratio wave sent in a shield box from the standard antenna and VSWR are confirmed in the picking out examination.

7 Warranty

If any defect occurs from the product during proper use within a year after delivery, it will be repaired or replaced free of charge.

8 Other

Any question arising from this specification manual shall be solved by arrangement made by both parties.

9 Precautions for use

- Antenna pattern use a Ag electrode.
- Please don't use the corrosion gas (sulfur gas, chlorine gas) in the atmosphere.
- Please don't direct solder onto the gold electrode of Antenna pattern.





| | | | | |
|--------------|------------------|-------------|------------|---|
| SPEC NO. | SP03AF07005-0010 | ISSUED DATE | 2013.10.30 | P |
| PRODUCT NAME | DPAN0S07 | VERSION | 01 | |
| | | PAGE | 9/13 | |

10 Drawings

Shape and Dimension

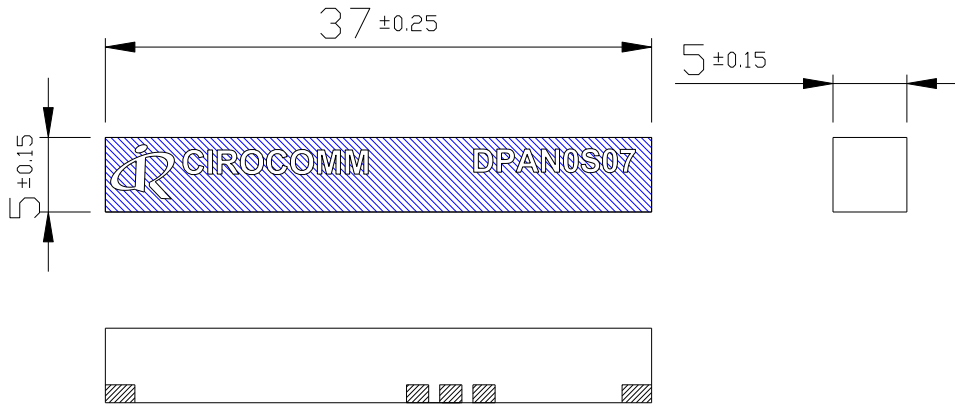

Unit:mm

Customer's Requirement Layout Dimension

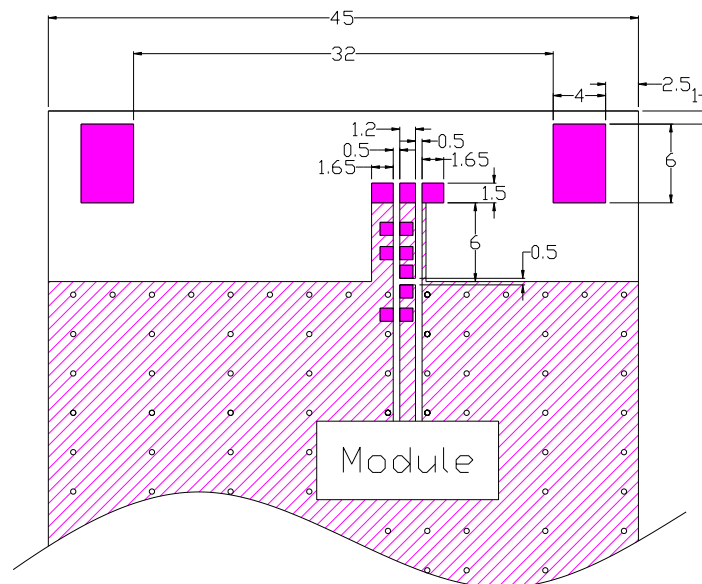

■ Matching circuit





| | | | | |
|--------------|------------------|-------------|------------|---|
| SPEC NO. | SP03AF07005-0010 | ISSUED DATE | 2013.10.30 | P |
| PRODUCT NAME | DPAN0S07 | VERSION | 01 | |
| | | PAGE | 10/13 | |

Recommend foot print for Evaluation Board

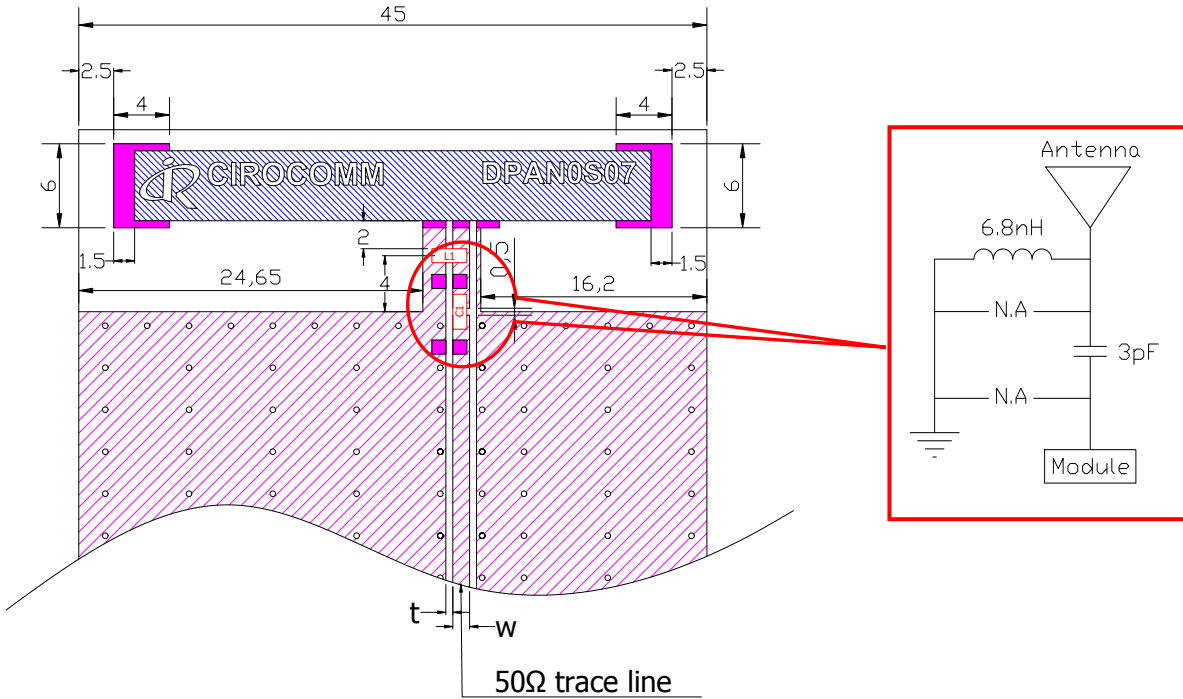

t,w=Unique dimensioning according to your PCB.

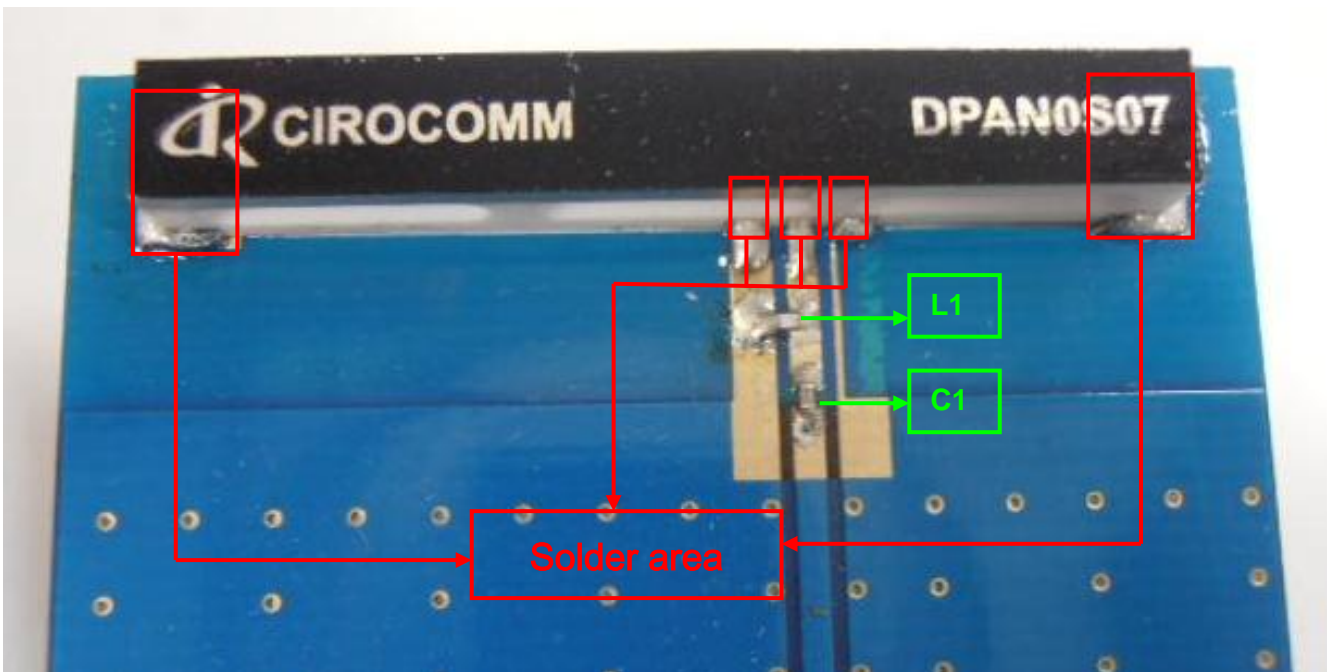

| Circuit Symbol | Size | Description |
|----------------|------|---------------------------------|
| L1 | 0402 | 6.8nH Inductor (MLK1005S15NIT) |
| C1 | 0402 | 3pF Capacitor (C1005C0G1H030CT) |





| | | | | |
|--------------|------------------|-------------|------------|---|
| SPEC NO. | SP03AF07005-0010 | ISSUED DATE | 2013.10.30 | P |
| PRODUCT NAME | DPAN0S07 | VERSION | 01 | |
| | | PAGE | 11/13 | |

Test board dimensions

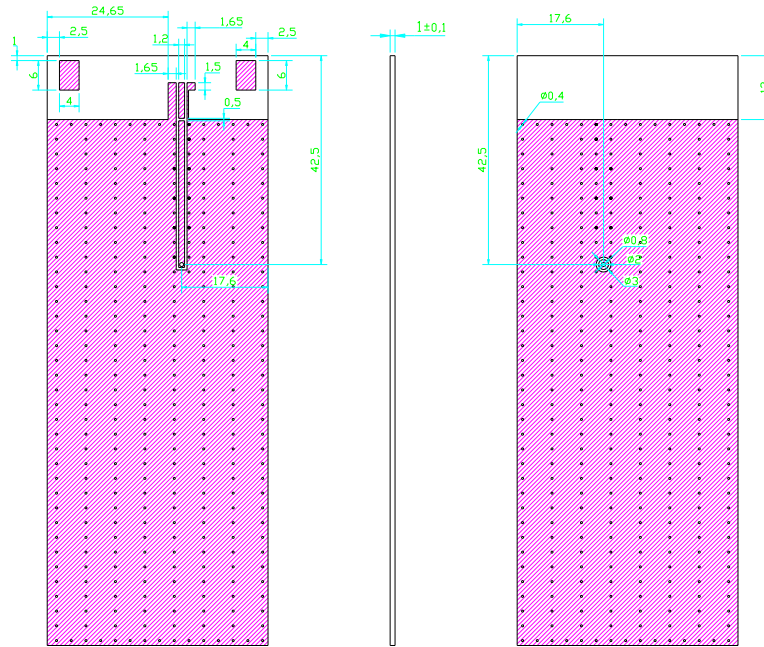

The test board is designed for evaluation purposes

Delivery mode

- 1 Blister tape to IEC 286-3 , polyester ◦
- 2 Pieces/tape : 450

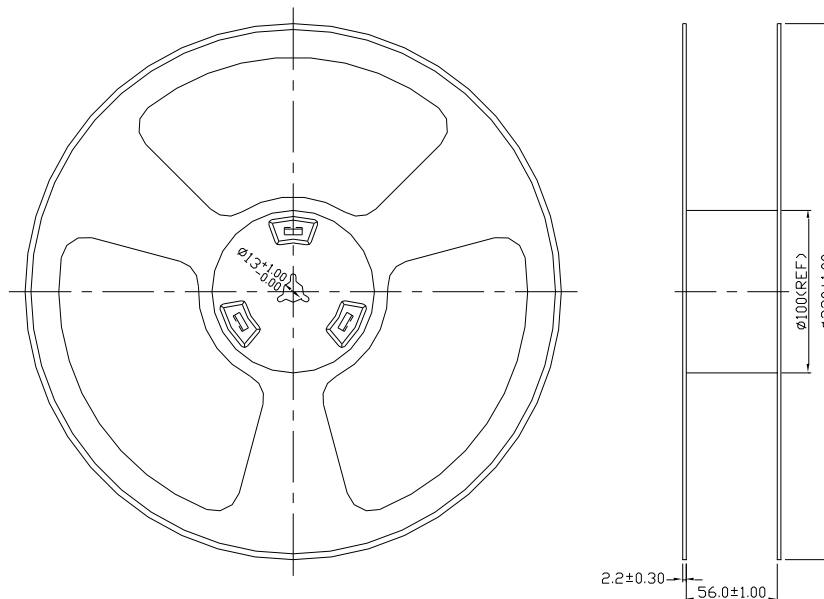



| | | | | |
|--------------|------------------|-------------|------------|---------------------|
| SPEC NO. | SP03AF07005-0010 | ISSUED DATE | 2013.10.30 | P |
| PRODUCT NAME | DPAN0S07 | VERSION | 01 | 2013.11.01 文件管制章 |
| | | PAGE | 13/13 | |

11 Recommended Reflow Temperature Profile

CIROCOMM's DPAN0S07 Planer Inverted-F antenna can be assembled following either Sn-Pb or Pb-free assembly. According to the Standard **IPC/JEDEC J-STD-020C**, the temperature profile suggested is as follow:

| Phase | Profile features | Sn-Pb Assembly | Pb-Free Assembly (SnAgCu) |
|------------------------------------|---|----------------------------------|----------------------------------|
| RAMP-UP | Avg. Ramp-up Rate (T _{smax} to TP) | 3°C/second (max) | 3°C/second(max) |
| PREHEAT | -Temperature Min(T _{Smin}) -Temperature Max(T _{Smin}) -Time(tsmin to tsmax) | 100°C 150°C 60-120 seconds | 100°C 150°C 60-120 seconds |
| REFLOW | -Temperature(TL) -Total Time above TL (t L) | 183°C 60-150 seconds | 217°C 60-150 seconds |
| PEAK | -Temperature(TP) -Time(tp) | 235°C 10-30 second | 260°C 20-40 second |
| RAMP-DOWN | Rate | 6°C / second max. | 6°C / second max. |
| Time from 25°C to Peak Temperature | | 6 minutes max. | 8 minutes max. |

Next graphic shows temperature profile(gray zone)for the antenna assembly process in reflow ovens.

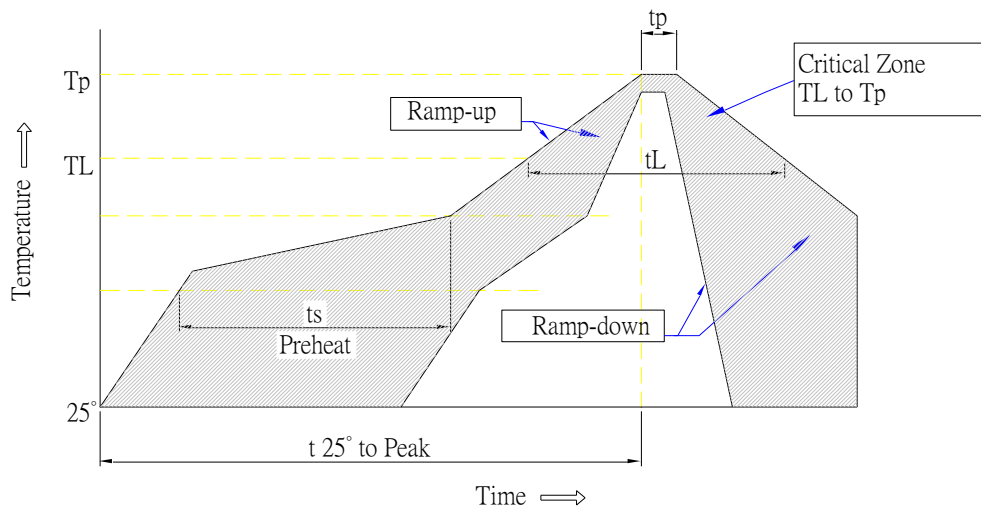

Temperatures profile

