

Specifications for

TFT-LCD Monitor

(2.0" QVGA 240 x RGB x 320 Portrait)

Version 1.0

(Please be sure to check the specifications latest version.)

MODEL COM20T2P98ILC

Customer's Approval

Signature :

Name :

Section :

Title :

Date :

ORTUSTECH

TOPPAN INC.
Electronics Division
Technological Development Department III

Approved by

S. Euchi



Checked by

J. Matsuzaki

Prepared by

M. Tojo

Version History

Ver.	Date	Page	Description	
0.0	Oct.12,2022	-	-	Tentative issue
0.1  ×16	May.24,2023	P.1		Cover
			Chenge	Department name
		P.5	Correct	2.1 Features of the Product
				Signal input method
			Correct	2.2 Display Method
				Signal input method
		P.11	Correct	6. Absolute Maximum Rating
				Condition,Rating
			Correct	7. Recommended Operating Conditions
				Rating
		P.13	Correct	8.2.1 CPU I/F timing Characteristics
				Error correct
		P.17	Correct	9.1 Parallel Interface
				Error correct
		P.19	Correct	9.3.1 Data Coding
				Error correct
P.21,22	Correct	10.1.1 Power ON Sequence		
		Remarks		
P.23,24	Correct	10.1.2 Refresh Sequence		
		Remarks		
P.26,27	Correct	10.2.1 Power ON Sequence		
		Remarks		
P.28,29	Correct	10.2.2 Refresh Sequence		
		Remarks		
1.0  ×2	Aug.25,2023	-	-	First issue
		P.33		12.1 Defective Display and Screen Quality
		Add		Signal condition
		P.35	Add	13. Reliability Test
			Add	number of failures /number of examinations

Contents

1. Application	4
2. Outline Specifications		
2.1 Features of the Product	5
2.2 Display Method	5
3. Dimensions and Shape		
3.1 Dimensions	6
3.2 Outward Form	7
3.3 Serial № print (S-print)	8
4. Pin Assignment	9
5. Block Diagram	10
6. Absolute Maximum Rating	11
7. Recommended Operating Conditions	11
8. Electrical Characteristics		
8.1 DC Characteristics	12
8.2 AC Characteristics	13
9. Interface		
9.1 Parallel Interface	17
9.2 Serial Interface	18
9.3 RGB Interface	19
10. Sequence		
10.1 CPU Interface	21
10.2 RGB Interface	26
11. Characteristics		
11.1 Optical Characteristics	31
11.2 Temperature Characteristics	32
12. Criteria of Judgment		
12.1 Defective Display and Screen Quality	33
12.2 Screen and Other Appearance	34
13. Reliability Test	35
14. Packing Specifications	37
15. Handling Instruction		
15.1 Cautions for Handling LCD panels	38
15.2 Precautions for Handling	39
15.3 Precautions for Operation	39
15.4 Storage Condition for Shipping Cartons	40
15.5 Precautions for Peeling off the Protective film	41
15.6 Warranty	41
APPENDIX	42

1. Application

This Specification is applicable to 51.0 mm (2.0 inch) TFT-LCD monitor for non-military use.

- ◎ TOPPAN makes no warranty or assume no liability that use of this Product and/or any information including drawings in this Specification by Purchaser is not infringing any patent or other intellectual property rights owned by third parties, and TOPPAN shall not grant to Purchaser any right to use any patent or other intellectual property rights owned by third parties. Since this Specification contains TOPPAN's confidential information and copy right, Purchaser shall use them with high degree of care to prevent any unauthorized use, disclosure, duplication, publication or dissemination of TOPPAN's confidential information and copy right.
- ◎ If Purchaser intends to use this Products for an application which requires higher level of reliability and/or safety in functionality and/or accuracy such as transport equipment (aircraft, train, automobile, etc.), disaster-prevention/security equipment or various safety equipment, Purchaser shall consult TOPPAN on such use in advance.
- ◎ This Product shall not be used for application which requires extremely higher level of reliability and/or safety such as aerospace equipment, telecommunication equipment for trunk lines, control equipment for nuclear facilities or life-support medical equipment.
- ◎ It must be noted as an mechanical design manner, especial attention in housing design to prevent arcuation/flexure caused by stress to the LCD module shall be considered.
- ◎ TOPPAN assumes no liability for any damage resulting from misuse, abuse, and/or miss-operation of the Product deviating from the operating conditions and precautions described in the Specification.
- ◎ It shall be mutually conferred if nonconforming defect which result from unspecified cause in this specification arises.
- ◎ If any issue arises as to information provided in this Specification or any other information, TOPPAN and Purchaser shall discuss them in good faith and seek solution.
- ◎ TOPPAN assumes no liability for defects such as electrostatic discharge failure occurred during peeling off the protective film or Purchaser's assembly process.
- ◎ This Product is compatible for RoHS(2.0) directive.

Object substance	Maximum content [ppm]
Cadmium and its compound	100
Hexavalent Chromium Compound	1000
Lead & Lead compound	1000
Mercury & Mercury compound	1000
Polybrominated biphenyl series (PBB series)	1000
Polybrominated biphenyl ether series (PBDE series)	1000
Bis(2-ethylhexyl)phthalate series(DEHP series)	1000
Butyl benzyl phthalate series(BBP series)	1000
Dibutyl phthalate series(DBP series)	1000
Diisobutyl phthalate series(DIBP series)	1000

3. Dimensions and Shape

3.1 Dimensions

Items	Specifications	Unit	Remarks
Outline dimensions	35.50[H] × 50.55[V] × 2.38[D]	mm	Exclude FPC cable
Active area	30.60[H] × 40.80[V]	mm	51 mm diagonal
Number of dots	240 × RGB [H] × 320[V]	dot	
Dot pitch	42.5[H] × 127.5[V]	um	
Surface hardness of the polarizer	3	H	Load:2.0N
Weight	10.7	g	Include FPC cable

EC No.	REV. No.	REVISE	DATE (Y-M-D)	APPROVED	CHECKED	PREPARED
####			##:##:##	##	##	##

(7/43)
22TLM069
Issue:Aug.25,2023

3.2 Outward Form

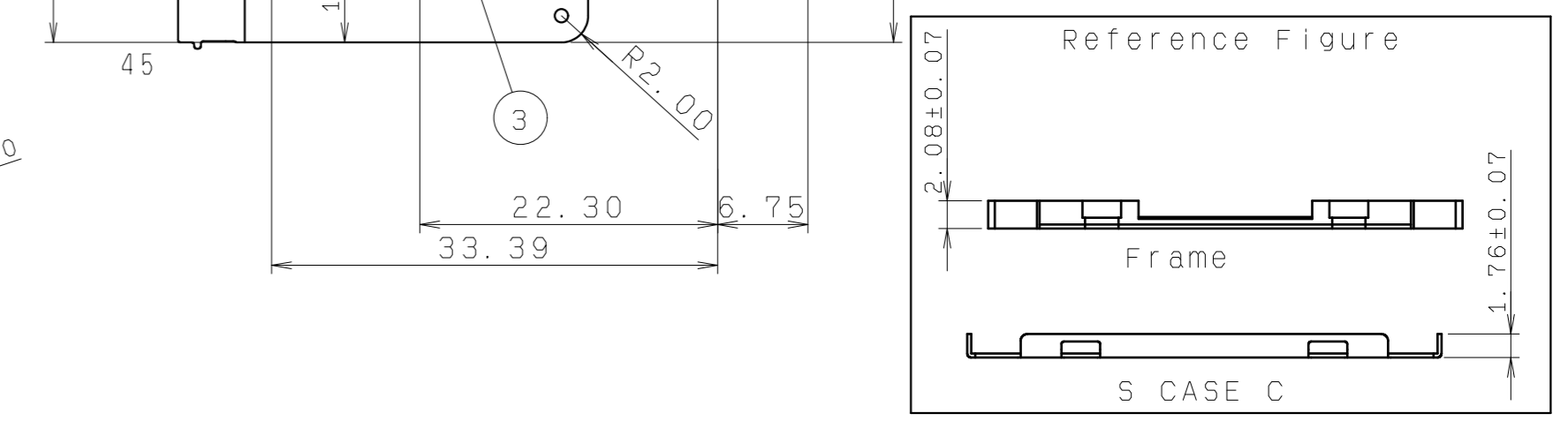
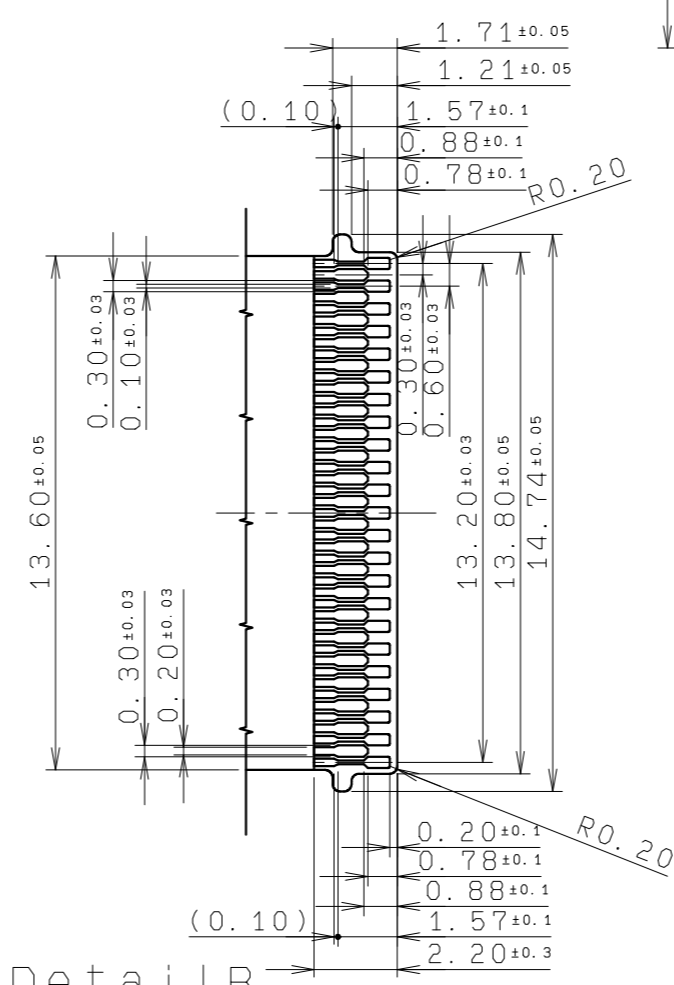
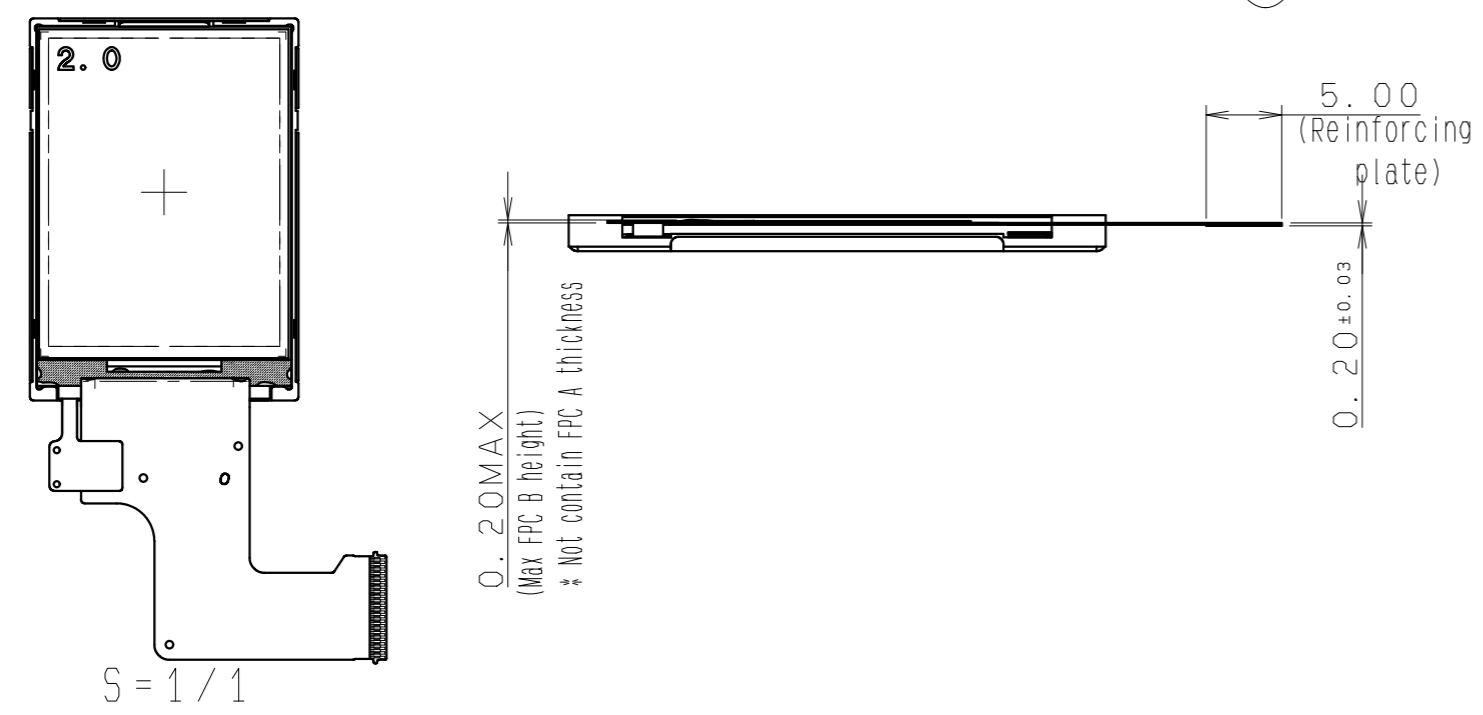
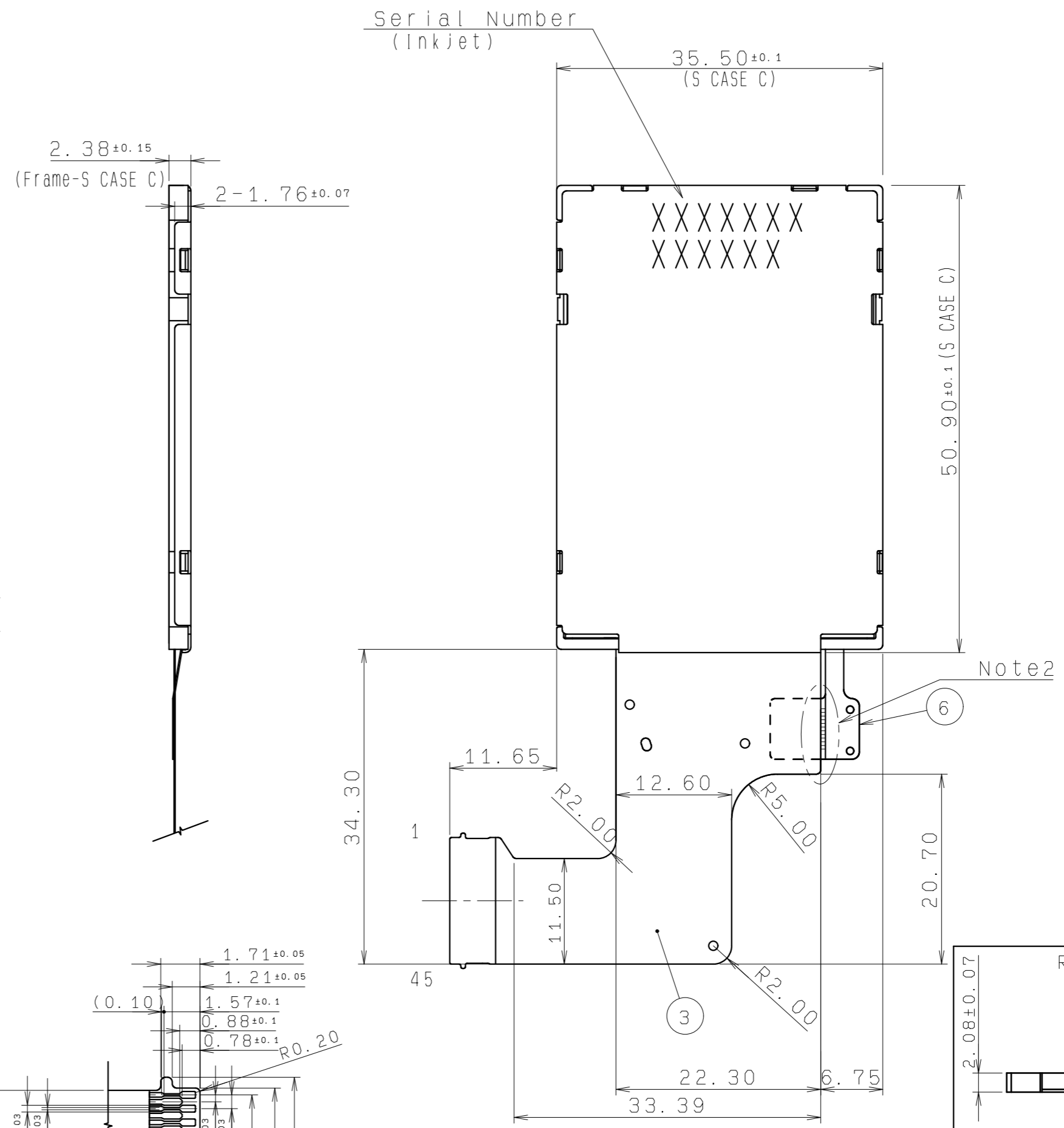
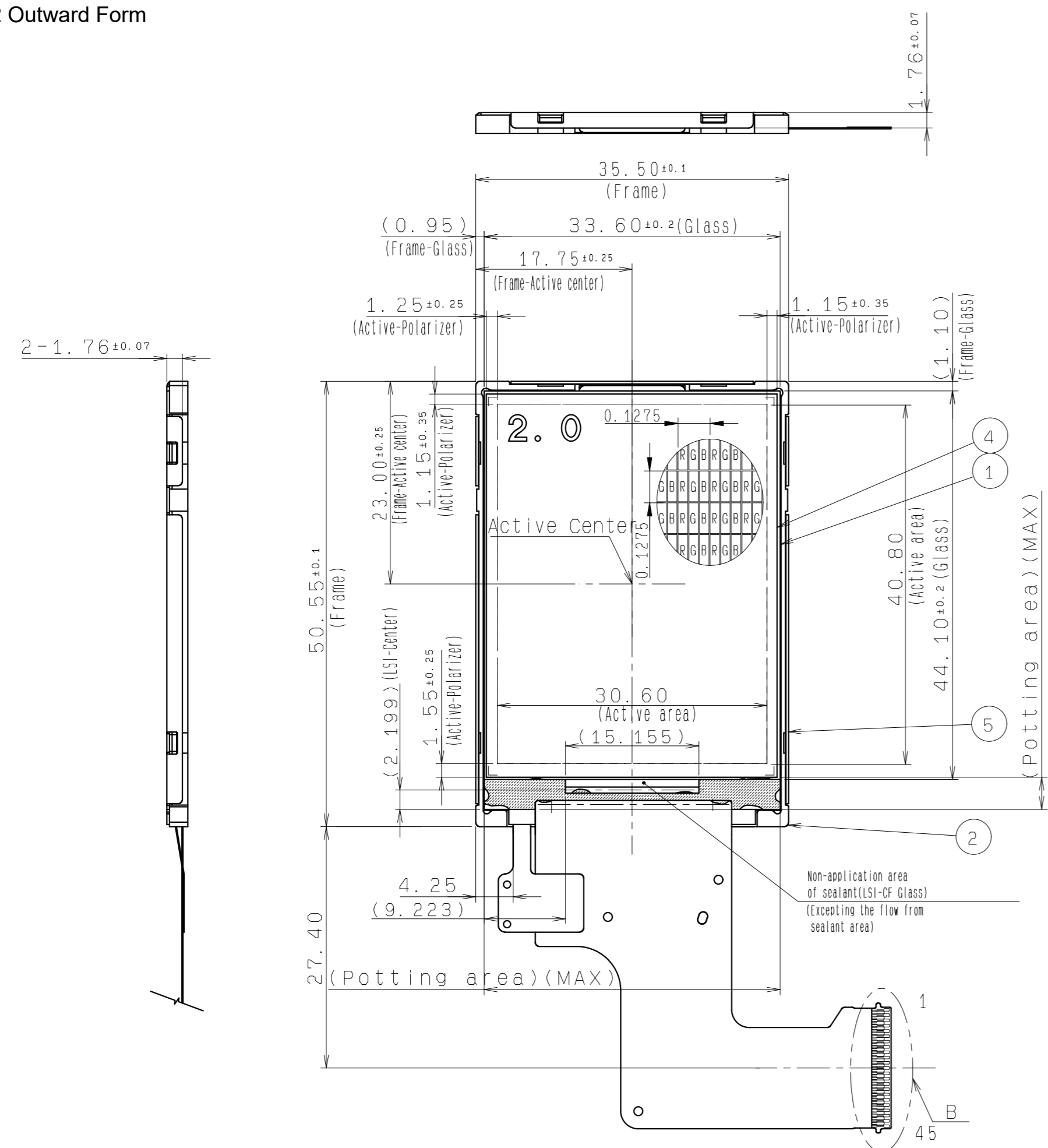

Note1. Constant-current circuit is required for the LED drive circuit. Note2. to make full use of original visual quality of the display. When other driving method is used for the LED driving circuit, original visual quality of the display is not guaranteed.

Note2. As shown in diagram, LED-FPC are opening. Their facing contact surface must be covered by solder resist.

FPC B	7			
S CASE C	6			Use of LED
Polarizer	5		SUS304 (t=0.3)	with protection sheet
FPC A	4			Use of LCD
Frame	3		PC	
TFT-LCD	2		Total thickness=1.0t	
PART NAME	ITEM	PART CODE	MODEL NUMBER	REMARK
APPROVED	木下大輔	GENERAL TOLERANCE ±0.5	SCALE 2/1(1/1.5/1)	UNIT mm
CHECKED	加藤真一	ISSUE (Y/M/D) 23:08:03	MODEL COM20T2P981**	
CHECKED	NAME			
DESIGN	雷田恵太			
DRAW	雷田恵太			

TOPPAN
TOPPAN INC.
DO NOT DUPLICATE, CONFIDENTIAL AND PROPRIETARY

DRAWING No. RJD603293D201 # /

REV. SHEET DIV. # /

OUTLINE-D2P98

3.3 Serial № print (S-print)

3.3.1 Display Items

S-print indicates the least significant digit of manufacture year (1digit), manufacture month with below alphabet (1letter), model code (5characters), serial number (6digits).

* Contents of Display

*	*	*****	*****
-	-	-----	-----
a	b	c	d

Contents of display				
a	The least significant digit of manufacture year			
b	Manufacture month	Jan-A Feb-B Mar-C Apr-D	May-E Jun-F Jul-G Aug-H	Sep-I Oct-J Nov-K Dec-L
c	Model code	20GXC (Made in Japan) 20GYC (Made in Malaysia)		
d	Serial number			

* Example of indication of Serial № print (S-print)

- Made in Japan

2L20GXC000125

means "manufactured in December 2022, 2.0" GX type, C specifications, serial number 000125"

- Made in Malaysia

2L20GYC000125

means "manufactured in December 2022, 2.0" GY type, C specifications, serial number 000125"

3.3.2 Location of Serial № print (S-print)

Refer to 3.2 "Outward Form".

3.3.3 Others

Please note that it is likely to disappear with an organic solvent about the Serial print.

4. Pin Assignment

No.	Symbol	Function	Remark	if not used
1	GND	Ground		
2	IM0	Select the MPU system I/F mode	18bit parallel: IM[3:0]=1010	
3	IM1	Select the MPU system I/F mode	16bit parallel: IM[3:0]=0010	
4	IM2	Select the MPU system I/F mode	4-line serial: IM[3:0]=1100	
5	IM3	Select the MPU system I/F mode	3-line serial: IM[3:0]=0101	
6	RESX	System reset signal input.(Lo: active)		
7	VSYNC	Vertical sync signal input for RGB I/F.		GND
8	HSYNC	Horizontal sync signal input for RGB I/F.		GND
9	DCLK	Dot clock signal input for RGB I/F.		GND
10	DE	Data Enable signal for RGB I/F.		GND
11	DB17	Bi-directional data bus		GND
12	DB16	Bi-directional data bus		GND
13	DB15	Bi-directional data bus		GND
14	DB14	Bi-directional data bus		GND
15	DB13	Bi-directional data bus		GND
16	DB12	Bi-directional data bus		GND
17	DB11	Bi-directional data bus		GND
18	DB10	Bi-directional data bus		GND
19	DB9	Bi-directional data bus		GND
20	DB8	Bi-directional data bus		GND
21	DB7	Bi-directional data bus		GND
22	DB6	Bi-directional data bus		GND
23	DB5	Bi-directional data bus		GND
24	DB4	Bi-directional data bus		GND
25	DB3	Bi-directional data bus		GND
26	DB2	Bi-directional data bus		GND
27	DB1	Bi-directional data bus		GND
28	DB0	Bi-directional data bus		GND
29	NC	Non connection		OPEN
30	SDA	SPI interface input /output.		GND
31	RDX	Read strobe signal.		IOVCC
32	WRX	Write strobe signal. (parallel)		GND
		Register select signal(4-line serial)		
33	DCX	Register select signal. (parallel)		
		Serial clock(RGB, serial)		
34	CSX	Chip select signal.		
35	GND	Ground		
36	TE	Output a frame head pulse.		OPEN
37	IOVCC	Logic Interface Power supply input.		
38	GND	Ground		
39	VDD	Power supply input.		
40	VDD	Power supply input.		
41	VLED	LED drive power source. (Anode side)		
42	VLED	LED drive power source. (Anode side)		
43	LEDK 3	LED drive power source. (Cathode side 3)		
44	LEDK 2	LED drive power source. (Cathode side 2)		
45	LEDK 1	LED drive power source. (Cathode side 1)		

- Recommended connector: JAE FB10S045JT1 or Molex 503566-4502
- Please make sure to check a consistency between pin assignment in "3.2 Outward Form" and your connector pin assignment when designing your circuit.
Inconsistency in input signal assignment may cause a malfunction.
- Since FPC cable has gold plated terminals, gilt finish contact shoe connector is recommended.

5. Block Diagram

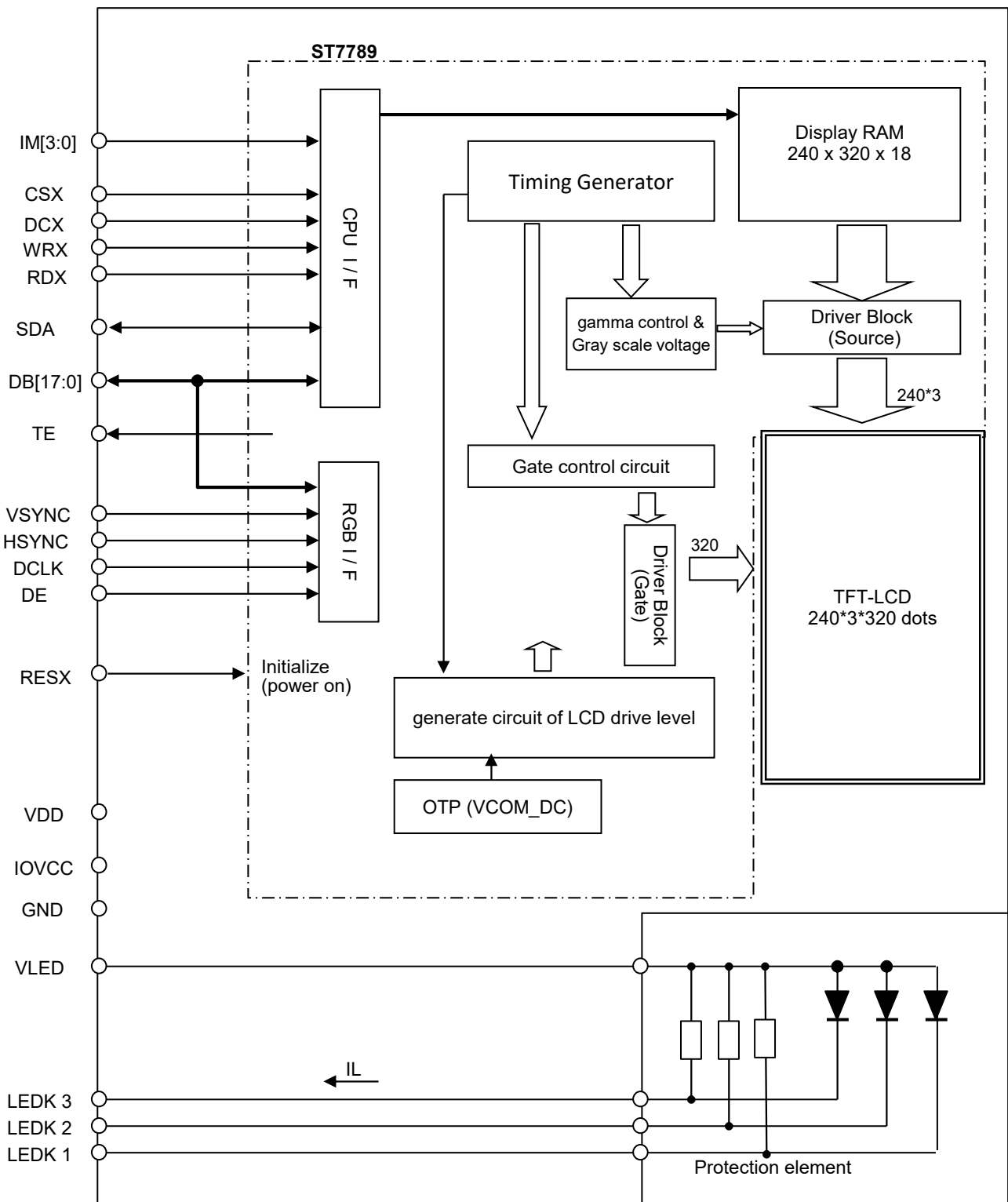

6. Absolute Maximum Rating

(GND=0V)

Item	Symbol	Condition	Rating		Unit	Applicable terminal
			MIN	MAX		
Supply voltage	VDD		-0.3	4.6	V	VDD
Logic interface voltage	IOVCC		-0.3	VDD	V	IOVCC
Input voltage for logic	VI		-0.3	IOVCC + 0.3	V	RESX,CSX,DCX,WRX, RDX,IM[3:0],DB[17:0],DE, VSYNC,HSYNC,DCLK,SDA
LED Forward current (Note)	IL	Ta=25°C	—	35	mA	VLED - LEDK1 VLED - LEDK2 VLED - LEDK3
		Ta=70°C	—	15		
Storage temperature range	Tstg		-30	80	°C	
Storage humidity range	Hstg	Non condensing in an environmental moisture at or less than 40 °C 90%RH.				

Note: Do not exceed Allowable Forward Current shown on the chart below.

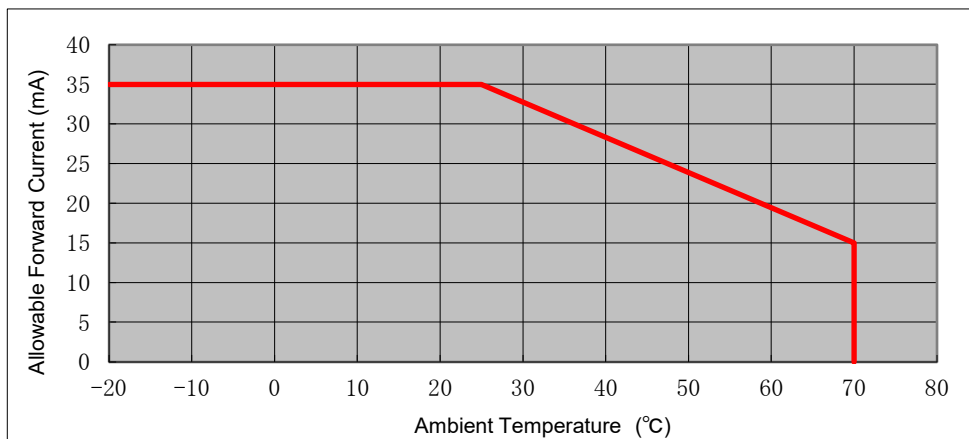

7. Recommended Operating Conditions

(GND=0V)

Item	Symbol	Condition	Rating			Unit	Applicable terminal
			MIN	TYP	MAX		
Supply voltage	VDD		2.8	3.0	3.3	V	VDD
Logic interface voltage	IOVCC	Ta=-20~70°C	2.8	VDD	VDD	V	IOVCC
Input voltage for logic	VI		0	—	IOVCC	V	RESX,CSX,DCX,WRX, RDX,IM[3:0],DB[17:0],DE, VSYNC,HSYNC,DCLK,SDA
Operational temperature range	Top	Note1	-20	25	70	°C	Panel surface temperature
Operating humidity range	Hop	Ta ≤ 40°C	20	—	85	%	
		Ta > 40°C	Non condensing in an environmental moisture at or less than 40 °C 85%RH.				

Note1: This monitor is operatable in this temperature range. With regard to optical characteristics, refer to Item 11 ."CHARACTERISTICS".

8. Electrical Characteristics

8.1 DC Characteristics

8.1.1 Display section

(Unless otherwise noted, Ta=25 °C, VDD=IOVCC=3.0V, GND=0V)

Item	Symbol	Condition	Rating			Unit	Applicable terminal
			MIN	TYP	MAX		
Input Signal Voltage 1	VIH	IOVCC=2.8-3.3V	0.7×IOVCC	—	IOVCC	V	RESX,CSX,DCX,WRX, RDX,IM[3:0],DB[17:0], DE,VSYNC,HSYNC, DCLK,SDA
	VIL		0	—	0.3×IOVCC	V	
Output Signal Voltage	VOH	IOH = -0.1mA	0.8×IOVCC	—	IOVCC	V	DB[17:0],TE,SDA
	VOL	IOL = 0.1mA	0	—	0.2×IOVCC	V	
Operating Current	IDD	Color bar display	—	6.5	13.0	mA	VDD + IOVCC
Stand-by Current	IDDS	Other input with constant voltage	—	-	40.0	µA	VDD + IOVCC

Note: Still image display status (color bar display) when CPU is not accessing the display RAM

8.1.2 Backlight section

項目	記号	条件	定格			単位	適用端子
			MIN	TYP	MAX		
LED current	IL	Ta=-20~70°C	-	10.0	15.0	mA	VLED - LEDK1 VLED - LEDK2 VLED - LEDK3
Forward voltage *Reference value	VL	Ta=25°C IL=10.0mA	-	2.75	3.05	V	
Estimated Life of LED , Note	LL	Ta=25°C IL=10.0mA	-	20,000	-	hrs	

Note:

- The lifetime of the LED is defined as a period till the brightness of the LED decreases to the half of its initial value.
- This figure is given as a reference purpose only, and not as a guarantee.
- This figure is estimated for an LED operating alone.
As the performance of an LED may differ when assembled as a monitor.
- Estimated lifetime could vary on a different temperature and usually higher temperature could reduce the life significantly.

8.2 AC Characteristics

8.2.1 CPU I/F timing Characteristics

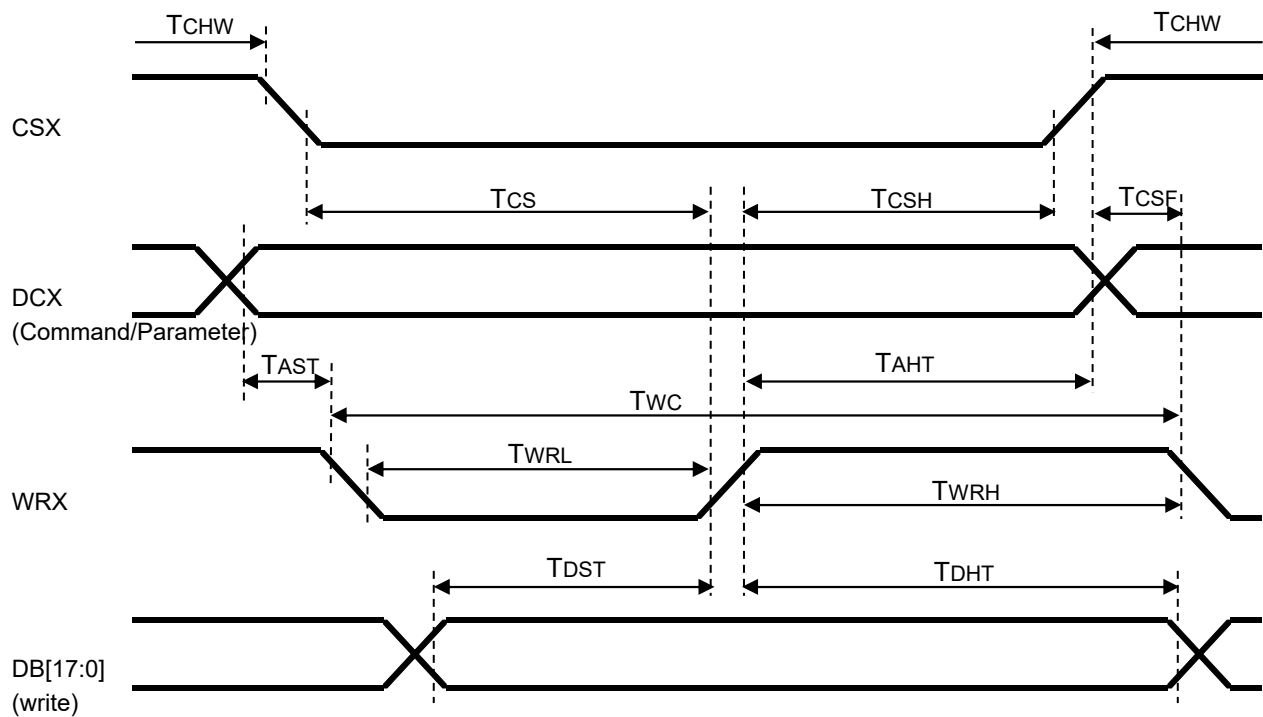
(Unless otherwise noted, $T_a=25\text{ }^\circ\text{C}$, $V_{DD}=I_{OVCC}=3.0\text{V}$, $GND=0\text{V}$)

Item	Symbol	Rating		Unit	
		MIN	MAX		
Address setup time	TAST	0		ns	DCX
Address hold time	TAHT	10		ns	
Chip select "H" pulse width	TCHW	0		ns	CSX
Chip select setup time	TCS	15		ns	
Chip select wait time	TCSF	10		ns	
Chip select hold time	TCSH	10		ns	
Write cycle	TWC	66		ns	WRX
WRX pulse "H" duration	TWRH	15		ns	
WRX pulse "L" duration	TWRL	15		ns	
Data setup time	TDST	10		ns	DB[17:0]
Data hold time	TDHT	10		ns	
Rising time	TR		15	ns	DCX,CSX,WRX, DB[17:0]
Falling time	TF		15	ns	

8.2.2 Serial I/F timing Characteristics

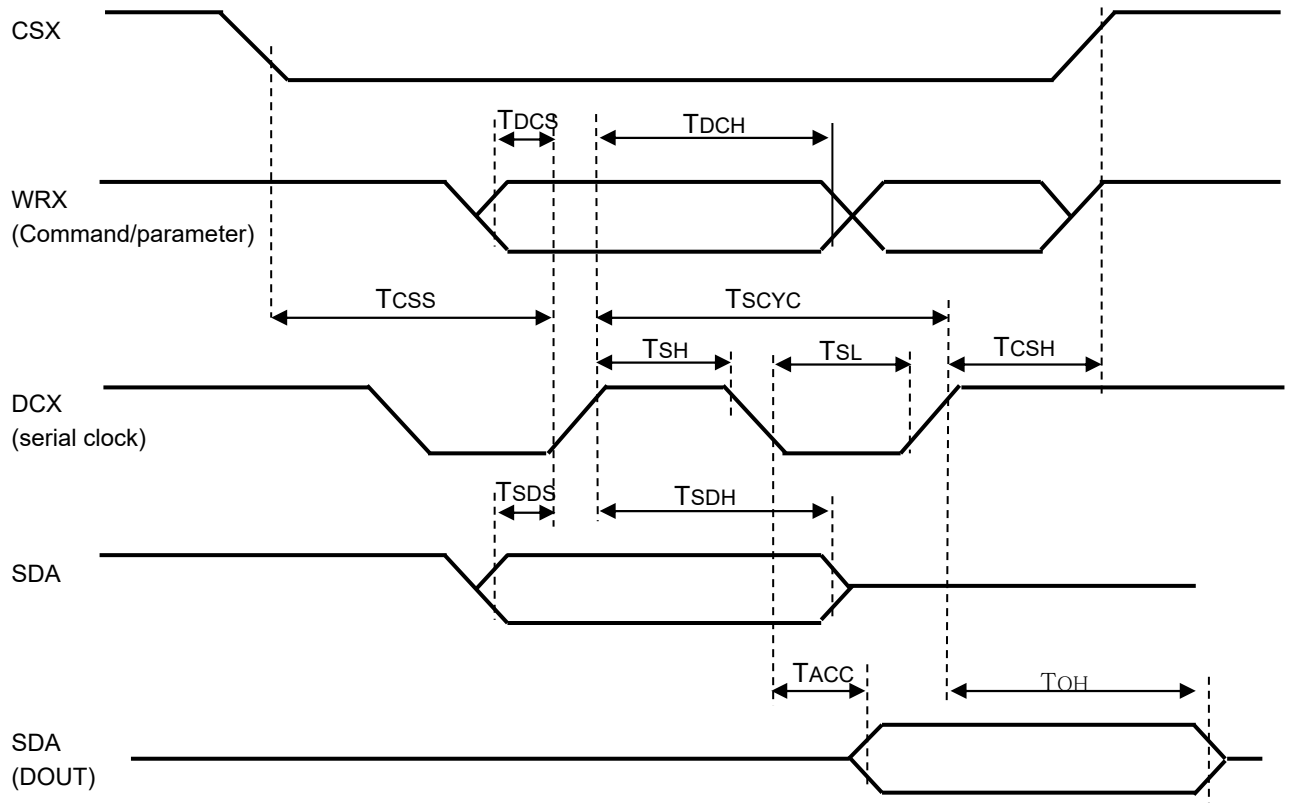
(Unless otherwise noted, $T_a=25\text{ }^\circ\text{C}$, $V_{DD}=I_{OVCC}=3.0\text{V}$, $GND=0\text{V}$)

Item	Symbol	Rating		Unit	
		MIN	MAX		
Chip Select Setup Time (Write)	TCSS	15		ns	CSX
Chip Select Hold Time (Write)	TCSH	15		ns	
Chip Select "H" Pulse Width (Write)	TCHW	40		ns	
Serial Clock Cycle (Write)	TSCYC	16		ns	DCX
Serial Clock "H" Pulse Width (Write)	TSHW	7		ns	
Serial Clock "L" Pulse Width (Write)	TSLW	7		ns	
D/CX Setup Time	TDCS	10		ns	WRX
D/CX Hold Time	TDCH	10		ns	
Data Setup Time	TSDS	7		ns	SDA
Data Hold Time	TSDH	7		ns	
Access Time	TACC	10	50	ns	SDA(DOUT)
Output disable Time	ToH	15	50	ns	

8.2.3 RGB I/F timing Characteristics

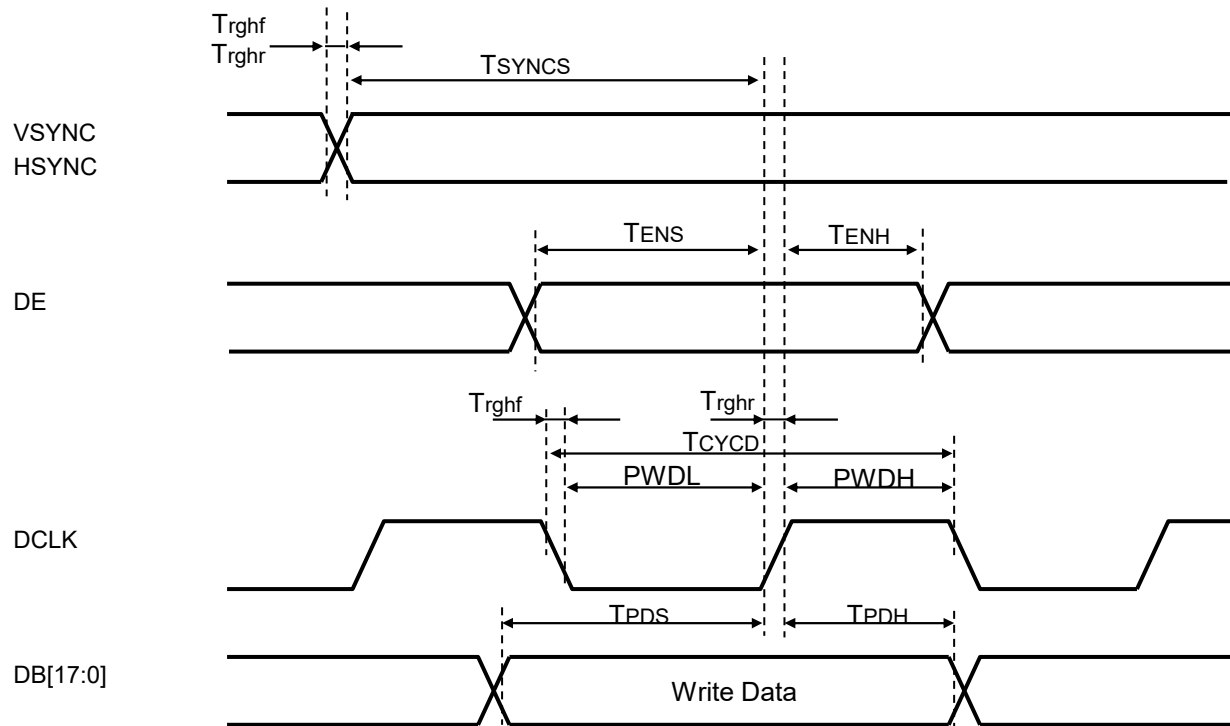
(Unless otherwise noted, $T_a=25\text{ }^\circ\text{C}$, $V_{DD}=I_{OVCC}=3.0\text{V}$, $GND=0\text{V}$)

Item	Symbol	Rating		Unit	
		MIN	MAX		
VSYNC,HSYNC Setup Time	TSYNCS	30		ns	HSYNC,VSYNC
ENABLE Setup Time	TENS	25		ns	DE
ENABLE Hold Time	TENH	25		ns	
DCLK High-level Pulse Width	PWDH	60		ns	DCLK
DCLK Low-level Pulse Width	PWDL	60		ns	
DCLK Cycle Time	TCYCD	120		ns	
Data Setup Time	TPDS	50		ns	DB[17:0]
Data Hold Time	TPDH	50		ns	
Signal Rise Time	Trghr		20	ns	HSYNC,VSYNC, DCLK,DE, DB[17:0]
Signal Fall Time	Trghf		20	ns	

8.2.4 RESET Timing

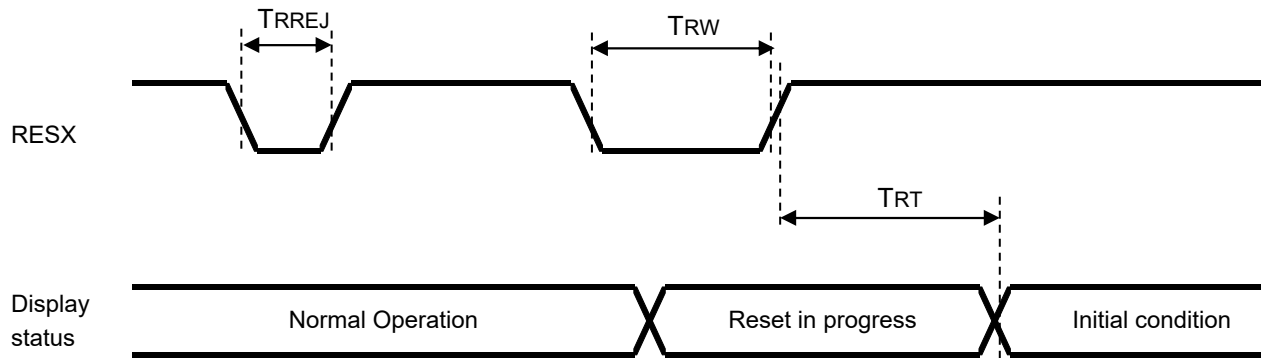
(Unless otherwise noted, $T_a=25\text{ }^\circ\text{C}$, $V_{DD}=IOVCC=3.0\text{V}$, $GND=0\text{V}$)

Item	Symbol	Rating		Unit	Remark
		MIN	MAX		
Reset rejected pulse width	TRREJ	-	5	us	
Reset pulse duration	TRW	10	-	us	
Reset time	TRT	-	5	ms	during in Sleep-in mode
		-	120	ms	during in Sleep-out mode

9. Interface

9.1 Parallel Interface

	Command	parameter	Display Data	
			CPU IF	
			18bit IF	16bit IF
IM3	*	*	1	0
IM2	0	0	0	0
IM1	1	1	1	1
IM0	0	0	0	0
		R B0h 1st IB4	RM	0
		R B0h 1st IB[1:0]	DM	00b
		R 3Ah 1st IB[6:4]	COLR	0h
		R 3Ah 1st IB[2:0]	CORM	6h 5h
		R B1h 1st IB[6:5]	RCM	00b
DCX	0	1	1	
DB17	0	0	R5	R5
DB16	0	0	R4	R4
DB15	0	0	R3	R3
DB14	0	0	R2	R2
DB13	0	0	R1	R1
DB12	0	0	R0	G5
DB11	0	0	G5	G4
DB10	0	0	G4	G3
DB9	0	0	G3	0
DB8	IB7	IB7	G2	G2
DB7	IB6	IB6	G1	G1
DB6	IB5	IB5	G0	G0
DB5	IB4	IB4	B5	B5
DB4	IB3	IB3	B4	B4
DB3	IB2	IB2	B3	B3
DB2	IB1	IB1	B2	B2
DB1	IB0	IB0	B1	B1
DB0	0	0	B0	0

9.2 Serial Interface

3-line serial interface protocol (IM[3:0] = 0101b)

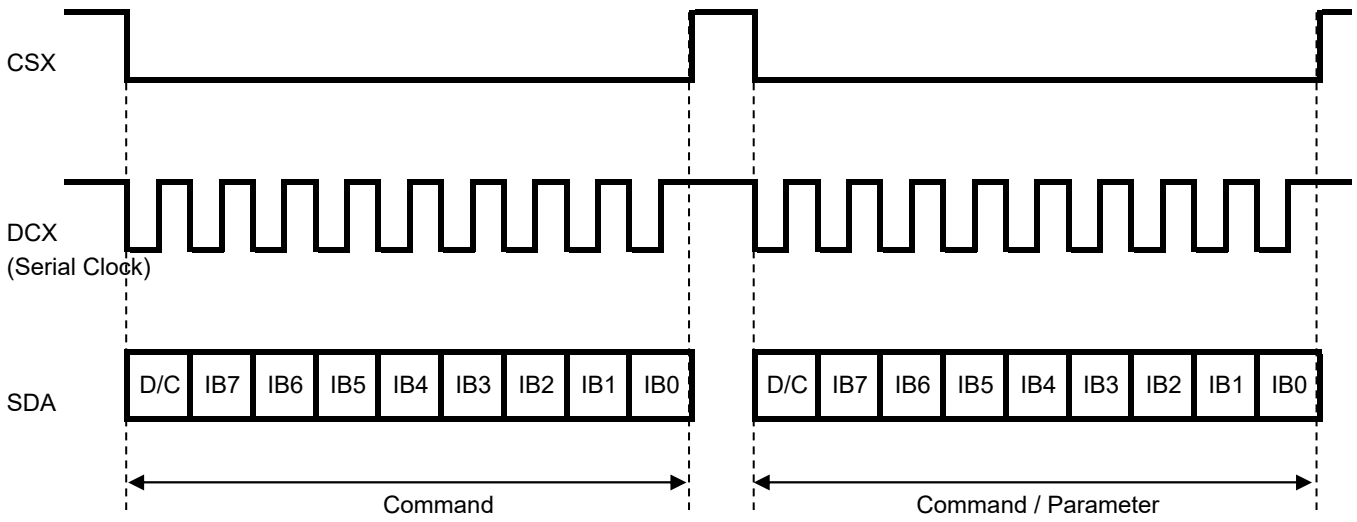

4-line serial interface protocol (IM[3:0] = 1100b)

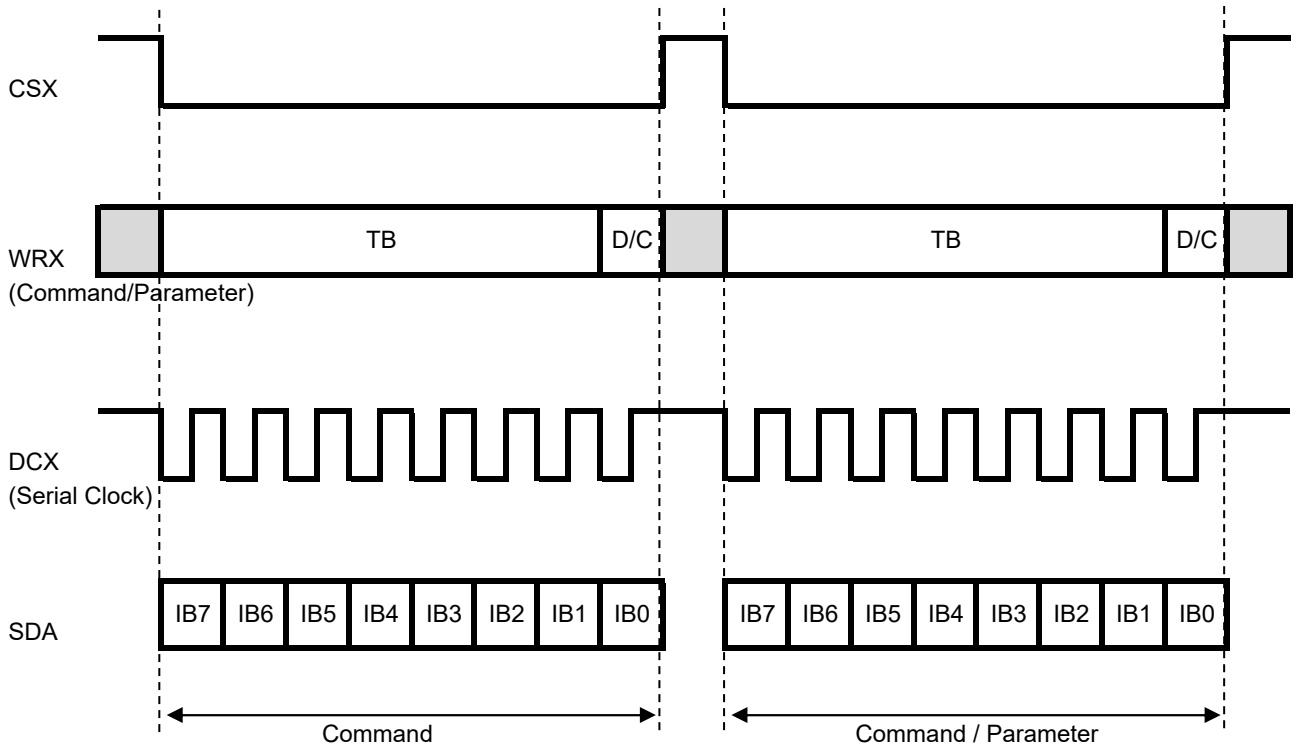

9.3 RGB Interface

9.3.1 Data Coding

Display Data		
RGB IF		
	18bit IF	16bit IF
IM3	0	
IM2	1	
IM1	0	
IM0	1	
R B0h 1st IB4	RM	1
R B0h 1st IB[1:0]	DM	01b
R 3Ah 1st IB[6:4]	COLR	6h 5h
R 3Ah 1st IB[2:0]	CORM	6h 5h
R B1h 1st IB[6:5]	RCM	01b

DB17	R5	R5
DB16	R4	R4
DB15	R3	R3
DB14	R2	R2
DB13	R1	R1
DB12	R0	0
DB11	G5	G5
DB10	G4	G4
DB9	G3	G3
DB8	G2	G2
DB7	G1	G1
DB6	G0	G0
DB5	B5	B5
DB4	B4	B4
DB3	B3	B3
DB2	B2	B2
DB1	B1	B1
DB0	B0	0

VSYNC	Valid ("L"active *)
HSYNC	Valid ("L"active *)
DCLK	Valid (rising edge *)
DE	Valid ("H"active *)

9.3.2 RGB Interface timing

Item	Symbol	MIN	TYP	MAX	Unit
VSYNC Cycle	VP	326	336		Line
VSYNC Low Width	VS	2	4	VS+VBP=127	Line
Vertical Back Porch	VBP	2	4		Line
Vertical Front Porch	VFP	2	8		Line
Vertical Display Period	VDISP	320	320	320	Line
Vertical Refresh Rate	VRR		60		Hz
HSYNC Cycle	HP	262	298		DCLK
HSYNC Low Width	HS	2	10	HS+HBP=31	DCLK
Horizontal Back Porch	HBP	4	10		DCLK
HS + HBP	HS+HBP	20	20	31	DCLK
Horizontal Front Porch	HFP	2	38	-	DCLK
Horizontal Display Period	HDISP	240	240	240	DCLK
Pixel CLK Frequency	PCLK		6	8.3	MHz

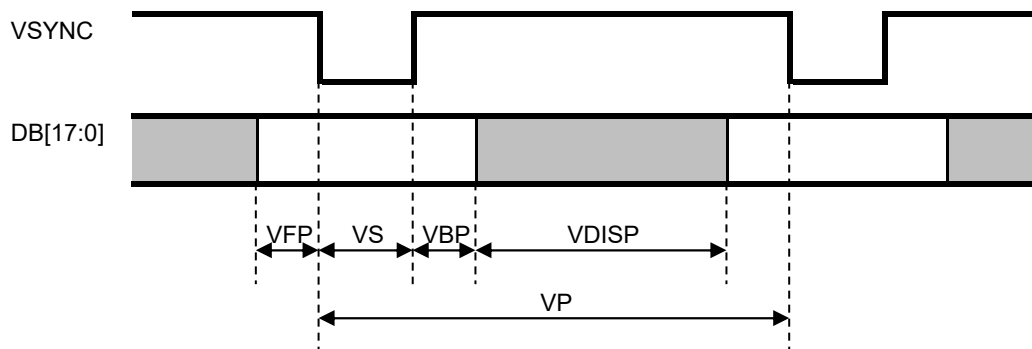
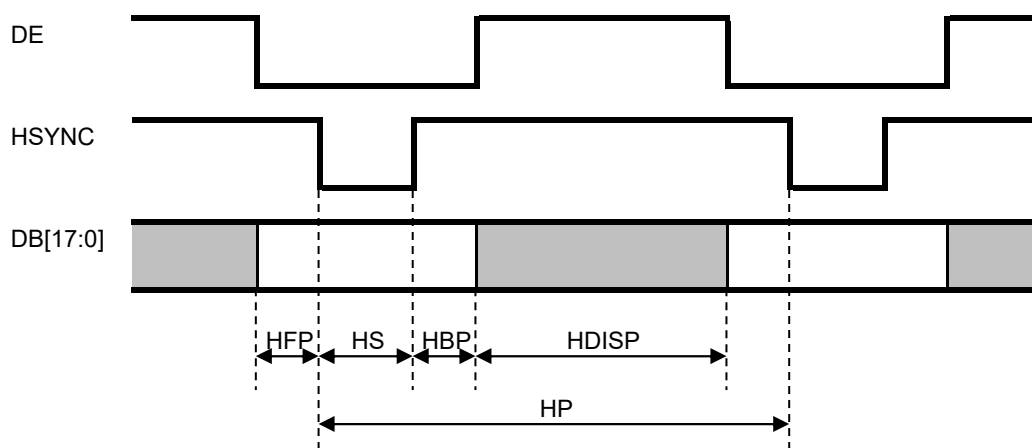
Vertical Timing**Horizontal Timing**

10. Sequence

10.1 CPU Interface

10.1.1 Power ON Sequence

(1/2)

No.		DCX	IB[7:0]	Remarks
	VDD/IOVCC ON			
	RESX High			(RESX High) can be omitted
	RESX High → Low			
	RESX Low			
	Wait 5 msec or more			
	RESX Low → High			
	Wait 120 msec or more			
1	Sleep Out	0	11 h	
	Wait 120 msec or more			
2	Memory access control	0	36 h	
	para 1	1	00 h	MX=MY=0
3	LCM Control	0	C0 h	
	para 1	1	3C h	XINV=XMV=XM=XBGR=1
4	Pixel format	0	3A h	
	para 1	1	05 h	5h:65k,6h:262k
5	CMD2EN	0	DF h	
	para 1	1	5A h	
	para 2	1	69 h	
	para 3	1	02 h	
	para 4	1	01 h	Command2 enable
6	GATECTRL 1	0	E4 h	
	para 1	1	27 h	NL=320
	para 2	1	00 h	SCN=G0
	para 3	1	10 h	TMG=1,SM=GS=0
7	GATECTRL 2	0	B7 h	
	para 1	1	75 h	VGH=14.9,VGL=-10.4
8	VCOMS setting	0	BB h	
	para 1	1	15 h	$\Delta v=0.625\text{typ}$
9	VAP/VAN signal	0	D2 h	
	para 1	1	00 h	
10	VRH set	0	C3 h	
	para 1	1	17 h	VAP=4.7+
11	Frame rate	0	C6 h	
	para 1	1	EF h	Column inversion,60Hz
12	Power control 1	0	D0 h	
	para 1	1	A4 h	
	para 2	1	A1 h	
13	Positive gamma	0	E0 h	
	para 1	1	F0 h	
	para 2	1	04 h	
	para 3	1	0B h	
	para 4	1	11 h	
	para 5	1	10 h	
	para 6	1	1B h	
	para 7	1	2F h	
	para 8	1	33 h	
	para 9	1	40 h	
	para 10	1	27 h	
	para 11	1	17 h	

(2/2)

No.		DCX	IB[7:0]	Remarks
	para 12	1	14 h	
	para 13	1	19 h	
	para 14	1	23 h	
	Wait 10 msec or more			
14	Negative gamma	0	E1 h	
	para 1	1	F0 h	
	para 2	1	04 h	
	para 3	1	0B h	
	para 4	1	11 h	
	para 5	1	10 h	
	para 6	1	1B h	
	para 7	1	2F h	
	para 8	1	33 h	
	para 9	1	40 h	
	para 10	1	27 h	
	para 11	1	17 h	
	para 12	1	14 h	
	para 13	1	19 h	
	para 14	1	23 h	
	Wait 10 msec or more			
15	Equalize control	0	E9 h	
	para 1	1	08 h	
	para 2	1	08 h	
	para 3	1	08 h	
16	RGB interface control	0	B1 h	
	para 1	1	00 h	
	para 2	1	04 h	
	para 3	1	14 h	
17	RAM Control	0	B0 h	
	para 1	1	00 h	CPU interface
	para 2	1	E0 h	
18	CA SET	0	2A h	
	para 1	1	00 h	XS[15:8]
	para 2	1	00 h	XS[7:0]
	para 3	1	00 h	XE[15:8]
	para 4	1	EF h	XE[7:0]
19	RA SET	0	2B h	
	para 1	1	00 h	YS[15:8]
	para 2	1	00 h	YS[7:0]
	para 3	1	01 h	YE[15:8]
	para 4	1	3F h	YE[7:0]
20	Tearing Effect On	0	35 h	
	para 1	1	00 h	TEM=0
21	RAMWR	0	2C h	
	data 1	1	**** h	write data
	data 2	1	**** h	write data
 h	
	data n	1	**** h	write data
	wait 10 msec or more			
22	Display ON	0	29 h	
	wait 10 msec or more			

10.1.2 Refresh Sequence

To prevent false operation by static electricity and such, please refresh register setting as follows regularly.

(1/2)

No.		DCX	IB[7:0]	Remarks
1	Sleep Out	0	11 h	
	Wait 120 msec or more			
2	Memory access control	0	36 h	
	para 1	1	00 h	MX=MY=0
3	LCM Control	0	C0 h	
	para 1	1	3C h	XINV=XMV=XXM=XBGR=1
4	Pixel format	0	3A h	
	para 1	1	05 h	5h:65k,6h:262k
5	CMD2EN	0	DF h	
	para 1	1	5A h	
	para 2	1	69 h	
	para 3	1	02 h	
	para 4	1	01 h	Command2 enable
6	GATECTRL 1	0	E4 h	
	para 1	1	27 h	NL=320
	para 2	1	00 h	SCN=G0
	para 3	1	10 h	TMG=1,SM=GS=0
7	GATECTRL 2	0	B7 h	
	para 1	1	75 h	VGH=14.9,VGL=-10.4
8	VCOMS setting	0	BB h	
	para 1	1	15 h	$\Delta v=0.625\text{typ}$
9	VAP/VAN signal	0	D2 h	
	para 1	1	00 h	
10	VRH set	0	C3 h	
	para 1	1	17 h	VAP=4.7+
11	Frame rate	0	C6 h	
	para 1	1	EF h	Column inversion,60Hz
12	Power control 1	0	D0 h	
	para 1	1	A4 h	
	para 2	1	A1 h	
13	Positive gamma	0	E0 h	
	para 1	1	F0 h	
	para 2	1	04 h	
	para 3	1	0B h	
	para 4	1	11 h	
	para 5	1	10 h	
	para 6	1	1B h	
	para 7	1	2F h	
	para 8	1	33 h	
	para 9	1	40 h	
	para 10	1	27 h	
para 11	1	17 h		

(2/2)

No.		DCX	IB[7:0]	Remarks
	para 12	1	14 h	
	para 13	1	19 h	
	para 14	1	23 h	
	Wait 10 msec or more			
14	Negative gamma	0	E1 h	
	para 1	1	F0 h	
	para 2	1	04 h	
	para 3	1	0B h	
	para 4	1	11 h	
	para 5	1	10 h	
	para 6	1	1B h	
	para 7	1	2F h	
	para 8	1	33 h	
	para 9	1	40 h	
	para 10	1	27 h	
	para 11	1	17 h	
	para 12	1	14 h	
	para 13	1	19 h	
	para 14	1	23 h	
	Wait 10 msec or more			
15	Equalize control	0	E9 h	
	para 1	1	08 h	
	para 2	1	08 h	
	para 3	1	08 h	
16	RGB interface control	0	B1 h	
	para 1	1	00 h	
	para 2	1	04 h	
	para 3	1	14 h	
17	RAM Control	0	B0 h	
	para 1	1	00 h	CPU interface
	para 2	1	E0 h	
18	CA SET	0	2A h	
	para 1	1	00 h	XS[15:8]
	para 2	1	00 h	XS[7:0]
	para 3	1	00 h	XE[15:8]
	para 4	1	EF h	XE[7:0]
19	RA SET	0	2B h	
	para 1	1	00 h	YS[15:8]
	para 2	1	00 h	YS[7:0]
	para 3	1	01 h	YE[15:8]
	para 4	1	3F h	YE[7:0]
20	Tearing Effect On	0	35 h	
	para 1	1	00 h	TEM=0
21	RAMWR	0	2C h	
	data 1	1	**** h	write data
	data 2	1	**** h	write data
 h	
	data n	1	**** h	write data
	wait 10 msec or more			
22	Display ON	0	29 h	
	wait 10 msec or more			

10.1.3 Sleep IN Sequence

No.		DCX	IB[7:0]	Remarks
1	Display OFF	0	28 h	
	Wait 10 msec or more			
2	Sleep In	0	10 h	

10.1.4 Sleep OUT Sequence

No.		DCX	IB[7:0]	Remarks
1	Sleep Out	0	11 h	
	Wait 120 msec or more			
2	Display ON	0	29 h	

10.1.5 Power OFF Sequence

No.		DCX	IB[7:0]	Remarks
1	Display OFF	0	28 h	
	Wait 10 msec or more			
2	Sleep In	0	10 h	
	Wait 120 msec or more			
3	RESX High → Low			
4	VDD/IOVCC OFF			

10.2 RGB Interface

10.2.1 Power ON Sequence

(1/2)

No.		DCX	IB[7:0]	Remarks
	VDD/IOVCC ON			
	RESX High	RESX Low		(RESX High) can be omitted
	RESX High → Low			
	Wait 5 msec or more			
	RESX Low → High			
	Wait 120 msec or more			
1	Sleep Out	0	11 h	
	Wait 120 msec or more			
2	Memory access control	0	36 h	
	para 1	1	00 h	MX=MY=0
3	LCM Control	0	C0 h	
	para 1	1	3C h	XINV=XMV=XM=XBGR=1
4	Pixel format	0	3A h	
	para 1	1	66 h	55h:65k,66h:262k
5	CMD2EN	0	DF h	
	para 1	1	5A h	
	para 2	1	69 h	
	para 3	1	02 h	
	para 4	1	01 h	Command2 enable
6	GATECTRL 1	0	E4 h	
	para 1	1	27 h	NL=320
	para 2	1	00 h	SCN=G0
	para 3	1	10 h	TMG=1,SM=GS=0
7	GATECTRL 2	0	B7 h	
	para 1	1	75 h	VGH=14.9,VGL=-10.4
8	VCOMS setting	0	BB h	
	para 1	1	15 h	$\Delta v=0.625\text{typ}$
9	VAP/VAN signal	0	D2 h	
	para 1	1	00 h	
10	VRH set	0	C3 h	
	para 1	1	17 h	VAP=4.7+
11	Frame rate	0	C6 h	
	para 1	1	EF h	Column inversion,60Hz
12	Power control 1	0	D0 h	
	para 1	1	A4 h	
	para 2	1	A1 h	
13	Positive gamma	0	E0 h	
	para 1	1	F0 h	
	para 2	1	04 h	
	para 3	1	0B h	
	para 4	1	11 h	
	para 5	1	10 h	
	para 6	1	1B h	
	para 7	1	2F h	
	para 8	1	33 h	
	para 9	1	40 h	
	para 10	1	27 h	
	para 11	1	17 h	

(2/2)

No.		DCX	IB[7:0]	Remarks
	para 12	1	14 h	
	para 13	1	19 h	
	para 14	1	23 h	
	Wait 10 msec or more			
14	Negative gamma	0	E1 h	
	para 1	1	F0 h	
	para 2	1	04 h	
	para 3	1	0B h	
	para 4	1	11 h	
	para 5	1	10 h	
	para 6	1	1B h	
	para 7	1	2F h	
	para 8	1	33 h	
	para 9	1	40 h	
	para 10	1	27 h	
	para 11	1	17 h	
	para 12	1	14 h	
	para 13	1	19 h	
	para 14	1	23 h	
	Wait 10 msec or more			
15	Equalize control	0	E9 h	
	para 1	1	08 h	
	para 2	1	08 h	
	para 3	1	05 h	
16	RGB interface control	0	B1 h	
	para 1	1	C0 h	
	para 2	1	08 h	
	para 3	1	14 h	
17	RAM Control	0	B0 h	
	para 1	1	11 h	RGB interface
	para 2	1	E0 h	
18	CA SET	0	2A h	
	para 1	1	00 h	XS[15:8]
	para 2	1	00 h	XS[7:0]
	para 3	1	00 h	XE[15:8]
	para 4	1	EF h	XE[7:0]
19	RA SET	0	2B h	
	para 1	1	00 h	YS[15:8]
	para 2	1	00 h	YS[7:0]
	para 3	1	01 h	YE[15:8]
	para 4	1	3F h	YE[7:0]
20	Gate On Timing Adjustment	0	B8 h	
	para 1	1	2A h	
	para 2	1	2B h	
	para 3	1	16 h	
	para 4	1	15 h	
21	RGB interface signal (HSYNC. VSYNC. DCLK DE) Input Start			
	wait 10 msec or more			
22	Display ON	0	29 h	
	wait 10 msec or more			

10.2.2 Refresh Sequence

To prevent false operation by static electricity and such, please refresh register setting as follows regularly.

(1/2)

No.		DCX	IB[7:0]	Remarks
1	Sleep Out	0	11 h	
	Wait 120 msec or more			
2	Memory access control	0	36 h	
	para 1	1	00 h	MX=MY=0
3	LCM Control	0	C0 h	
	para 1	1	3C h	XINV=XMV=XXM=XBGR=1
4	Pixel format	0	3A h	
	para 1	1	66 h	55h:65k,66h:262k
5	CMD2EN	0	DF h	
	para 1	1	5A h	
	para 2	1	69 h	
	para 3	1	02 h	
	para 4	1	01 h	Command2 enable
6	GATECTRL 1	0	E4 h	
	para 1	1	27 h	NL=320
	para 2	1	00 h	SCN=G0
	para 3	1	10 h	TMG=1,SM=GS=0
7	GATECTRL 2	0	B7 h	
	para 1	1	75 h	VGH=14.9,VGL=-10.4
8	VCOMS setting	0	BB h	
	para 1	1	15 h	$\Delta v=0.625\text{typ}$
9	VAP/VAN signal	0	D2 h	
	para 1	1	00 h	
10	VRH set	0	C3 h	
	para 1	1	17 h	VAP=4.7+
11	Frame rate	0	C6 h	
	para 1	1	EF h	Column inversion,60Hz
12	Power control 1	0	D0 h	
	para 1	1	A4 h	
	para 2	1	A1 h	
13	Positive gamma	0	E0 h	
	para 1	1	F0 h	
	para 2	1	04 h	
	para 3	1	0B h	
	para 4	1	11 h	
	para 5	1	10 h	
	para 6	1	1B h	
	para 7	1	2F h	
	para 8	1	33 h	
	para 9	1	40 h	
	para 10	1	27 h	
para 11	1	17 h		

(2/2)

No.		DCX	IB[7:0]	Remarks
	para 12	1	14 h	
	para 13	1	19 h	
	para 14	1	23 h	
	Wait 10 msec or more			
14	Negative gamma	0	E1 h	
	para 1	1	F0 h	
	para 2	1	04 h	
	para 3	1	0B h	
	para 4	1	11 h	
	para 5	1	10 h	
	para 6	1	1B h	
	para 7	1	2F h	
	para 8	1	33 h	
	para 9	1	40 h	
	para 10	1	27 h	
	para 11	1	17 h	
	para 12	1	14 h	
	para 13	1	19 h	
	para 14	1	23 h	
	Wait 10 msec or more			
15	Equalize control	0	E9 h	
	para 1	1	08 h	
	para 2	1	08 h	
	para 3	1	05 h	
16	RGB interface control	0	B1 h	
	para 1	1	C0 h	
	para 2	1	08 h	
	para 3	1	14 h	
17	RAM Control	0	B0 h	
	para 1	1	11 h	RGB interface
	para 2	1	E0 h	
18	CA SET	0	2A h	
	para 1	1	00 h	XS[15:8]
	para 2	1	00 h	XS[7:0]
	para 3	1	00 h	XE[15:8]
	para 4	1	EF h	XE[7:0]
19	RA SET	0	2B h	
	para 1	1	00 h	YS[15:8]
	para 2	1	00 h	YS[7:0]
	para 3	1	01 h	YE[15:8]
	para 4	1	3F h	YE[7:0]
20	Gate On Timing Adjustment	0	B8 h	
	para 1	1	2A h	
	para 2	1	2B h	
	para 3	1	16 h	
	para 4	1	15 h	
21	RGB interface signal (HSYNC. VSYNC. DCLK DE) Input Start			
	wait 10 msec or more			
22	Display ON	0	29 h	
	wait 10 msec or more			

10.2.3 Sleep IN Sequence

No.		DCX	IB[7:0]	Remarks
1	Display OFF	0	28 h	
	Wait 10 msec or more			
	Stop inputting RGB interface signals (VSYNC, HSYNC, DCLK, DE)			
2	Sleep In	0	10 h	

10.2.4 Sleep OUT Sequence

No.		DCX	IB[7:0]	Remarks
1	Sleep Out	0	11 h	
	Start inputting RGB interface signals (VSYNC, HSYNC, DCLK, DE)			
	Wait 120 msec or more			
2	Display ON	0	29 h	

10.2.5 Power OFF Sequence

No.		DCX	IB[7:0]	Remarks
1	Display OFF	0	28 h	
	Wait 10 msec or more			
	Stop inputting RGB interface signals (VSYNC, HSYNC, DCLK, DE)			
2	Sleep In	0	10 h	
	Wait 120 msec or more			
3	RESX High → Low			
4	VDD/IOVCC OFF			

11. Characteristics

11.1 Optical Characteristics

(Measurement Condition)

Measuring instruments: CS2000 (KONICA MINOLTA), LCD7200 (OTSUKA ELECTRONICS), EZcontrastXL88 (ELDIM)

Driving condition: VDD=IOVCC=3.0V, GND=0V, Optimized VCOMDC

Backlight: IL=10.0 mA

Measured temperature: Ta = 25°C

Item		Symbol	Condition	MIN	TYP	MAX	Unit	Note №	Remark
Response time	Rise time	TON	[Data]= 00h← → 3Fh	-	-	100	ms	1	
	+ Fall time	TOFF							
Contrast ratio		CR	[Data]= 3Fh / 00h	400	800	-		2	
Viewing angle	Left	θL	[Data]= 3Fh / 00h CR ≥ 10	-	80	-	deg	3	
	Right	θR		-	80	-	deg		
	Up	φU		-	80	-	deg		
	Down	φD		-	80	-	deg		
White Chromaticity		x y	[Data]= 3Fh	White chromaticity range				4	
Center Brightness			[Data]= 3Fh	310	450	-	cd/m ²	5	
Brightness distribution			[Data]= 3Fh	70	-	-	%	6	
Burn-in				No noticeable burn-in image shall be observed after 2 hours of window pattern display.				7	

* Note number 1 to 7: Refer to the APPENDIX of "Reference Method for Measuring Optical Characteristics and Performance".

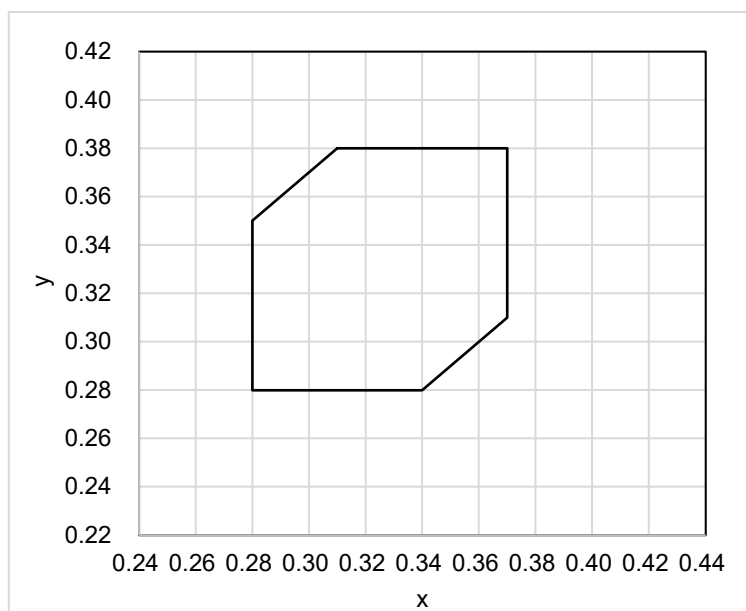

(White Chromaticity Range)

x	y
0.31	0.38
0.28	0.35
0.28	0.28
0.34	0.28
0.37	0.31
0.37	0.38

White Chromaticity Range

11.2 Temperature Characteristics

(Measurement Condition)

Measuring instruments: CS2000 (KONICA MINOLTA), LCD7200 (OTSUKA ELECTRONICS)

Driving condition: VDD=IOVCC=3.0V, GND=0V, Optimized VCOMDC

Backlight: IL=10.0 mA

Item		Symbol	Specification		Remark
			Ta = -20 °C	Ta = 70 °C	
Response time	Rise time + Fall time	TON + TOFF	500 msec or less	80 msec or less	
Contrast ratio		CR	40 or more	40 or more	
Display Quality			No noticeable display defect or ununiformity should be observed.		

12. Criteria of Judgment

12.1 Defective Display and Screen Quality

-  Test Condition: Observed TFT-LCD monitor from front during operation with the following conditions
 Driving Signal: Raster Patter (RGB, white, black)
 Signal condition: [Data]:00h, 25h, 3Fh (3steps)
 Observation distance: 30 cm
 Illuminance: 200 to 350 lx
 Backlight: IL=10.0mA

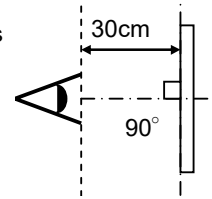

Defect item	Defect content	Criteria		
Display Quality	Line defect	Black, white or color line, 3 or more neighboring defective dots	Not exists	
	Dot defect	Uneven brightness on dot-by-dot base due to defective TFT or CF, or dust is counted as dot defect (brighter dot, darker dot)	Refer to table 1	
		High bright dot: Visible through 2% ND filter at [Data]=00h		
		Low bright dot: Visible through 5% ND filter at [Data]=00h Dark dot: Appear dark through white display at [Data]=25h Invisible through 5% ND filter at [Data]=00h	Acceptable	
Screen Quality	Stain	Uneven brightness (white stain, black stain etc)	Invisible through 5% ND filter at Black screen. Invisible through 1% ND filter at other screen.	
	Foreign particle	Point-like	$0.25\text{mm} < \varphi$	N=0
			$0.20\text{mm} < \varphi \leq 0.25\text{mm}$	$N \leq 2$
			$\varphi \leq 0.20\text{mm}$	Acceptable
	Liner	$3.0\text{mm} < \text{length and } 0.08\text{mm} < \text{width}$	N=0	
$\text{length} \leq 3.0\text{mm}$ or $\text{width} \leq 0.08\text{mm}$		Acceptable		
Others		Use boundary sample for judgment when necessary		

φ (mm): Average diameter = (major axis + minor axis)/2
 Permissible number: N

Table1

Area	High bright dot	Low bright dot	Dark dot	Total	Criteria
A	0	2	2	3	Permissible distance between same color bright dots (includes neighboring dots): 3 mm or more Permissible distance between same color high bright dots (includes neighboring dots): 5 mm or more
B	2	4	4	5	
Total	2	4	4	5	

<Portrait model>

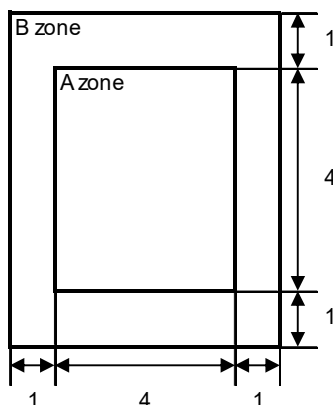

Division of A and B areas

B area: Active area

Dimensional ratio between A and B areas: 1: 4: 1

(Refer to the left figure)

12.2 Screen and Other Appearance

Testing conditions

Observation distance : 30 cm

Illuminance : 1200 ~ 2000 lx

Item	Criteria	Remark
Polarizer Flaw Stain Dirt Bubble Dust Dent	Ignore invisible defect when the backlight is on.	Applicable area: Active area only (Refer to the section 3.2 Outward Form)
S case	No functional defect occurs	
FPC	No functional defect occurs	

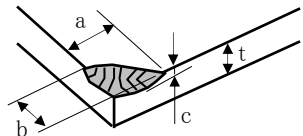
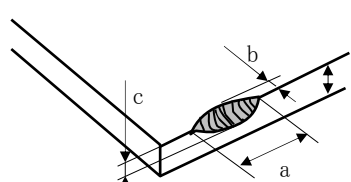
Item	Appearance	Criteria
Glass chipping	Corner area 	Unit : mm $a \leq 3$ $b \leq 3$ $c \leq t$ (t: glass thickness) $a, b \leq 0.5$ is acceptable $n \leq 2$
	Others 	Unit : mm $a \leq 5$ $b \leq 1$ $c \leq t$ (t: glass thickness) $a, b \leq 0.5$ is acceptable Maximum permissible number of chipping off on a side is 5.
	Progressive crack	None

13. Reliability Test

Test item		Test condition		number of failures / number of examinations
Durability test	High temperature storage	Ta = 80°C	240hrs	0 / 3
	Low temperature storage	Ta = -30°C	240hrs	0 / 3
	High temperature & high humidity storage	Ta = 60°C, RH = 90%, non condensing	240hrs	0 / 3
	High temperature operation	Tp = 70°C	240hrs	0 / 3
	Low temperature operation	Tp = -20°C	240hrs	0 / 3
	High temperature & high humidity operation	Tp = 40°C, RH = 90%, non condensing	240hrs	0 / 3
	Thermal shock storage	-30°C ↔ 80°C (30min / 30min)	100cycles	0 / 3
Mechanical environmental test	Electrostatic discharge test (Non operation)	Confirms to EIAJ ED-4701/300, C=200pF,R=0Ω,V=±200V Each 3 times of discharge on and power supply and other terminals.		0 / 3
	Surface discharge test (Non operation)	C=250pF, R=100Ω, V=±6.0kV Each 5 times of discharge in both polarities on the center of screen with the case grounded.		0 / 3
	Vibration test	Total amplitude 1.5mm, f=10~55Hz, X,Y,Z directions for each 2 hours		0 / 3
	Impact test	Use TOPPAN original jig (see next page) and make an impact with peak acceleration of 1000m/s ² for 6 msec with half sine-curve at 3 times to each X, Y, Z directions in conformance with JIS C 60068-2-27-2011.		0 / 3
Packing test	Packing vibration-proof test	Acceleration of 19.6m/s ² with frequency of 10→55→10Hz, X,Y, Zdirection for each 30 minutes.		0 / 1 packing
	Packing drop test	Drop from 75cm high. 1 time to each 6 surfaces, 3 edges, 1 corner		0 / 1 packing

Note: Ta=ambient temperature Tp=Panel temperature

※ The profile of high temperature/humidity storage and High Temperature/humidity operation (Pure water of over 10MΩ·cm shall be used.)

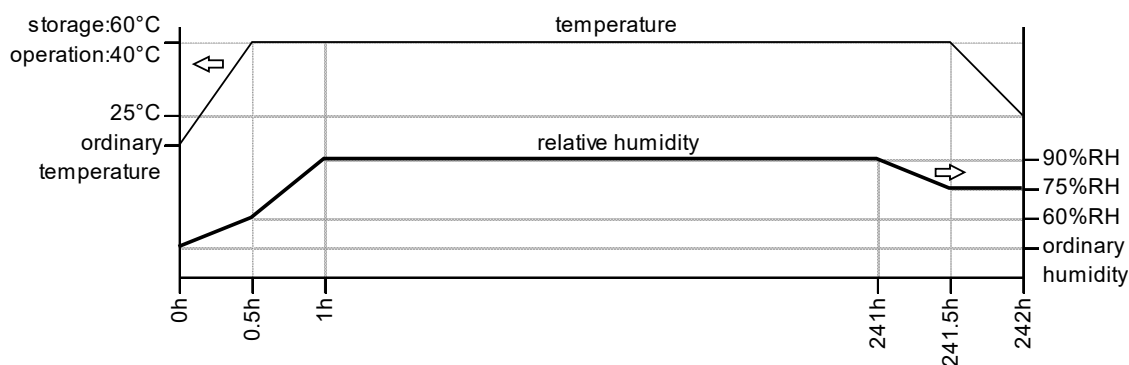
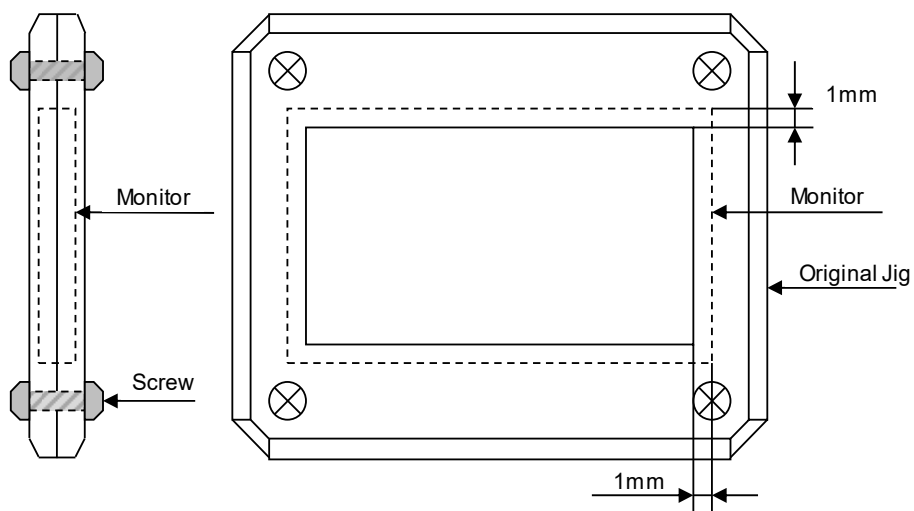

Table2. Reliability Criteria

The parameters should be measured after leaving the monitor at the ordinary temperature for 24 hours or more after the test completion.

Item	Standard	Remark
Display quality	No visible abnormality shall be seen. (Except for unevenness by Pol deterioration.)	
Contrast ratio	40 or more	Backlight ON

TOPPAN Original Jig



14. Packing Specifications

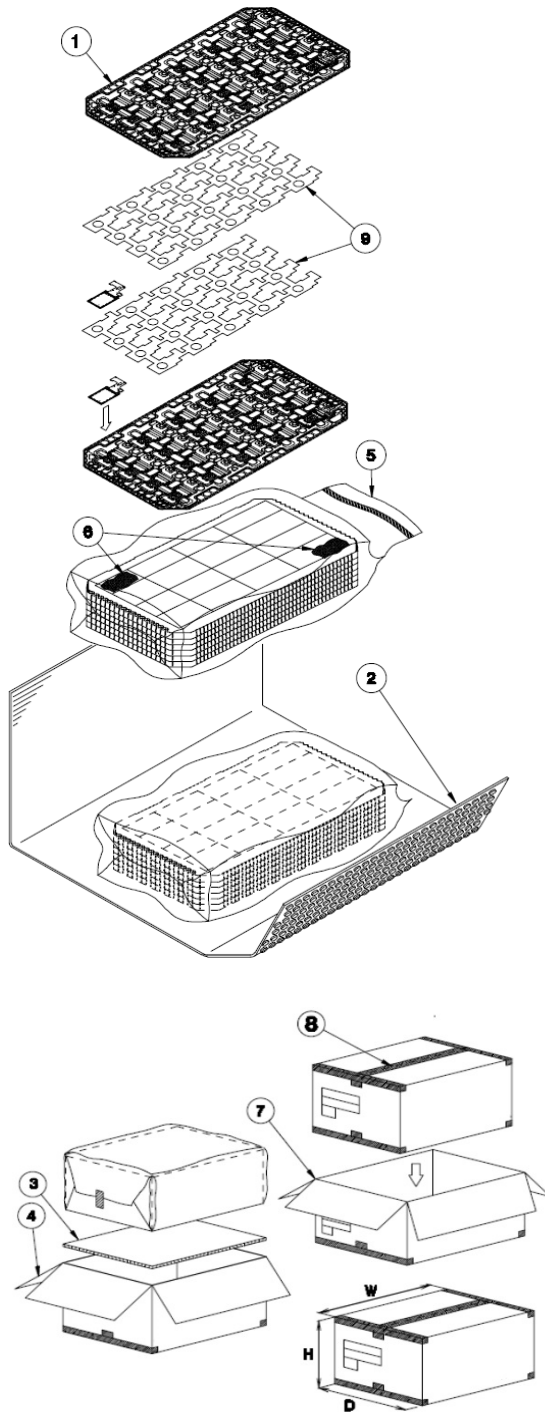

- Step 1. Each product is to be placed in one of the cut-outs of the tray with its the display surface facing upward, and FOAM SHEET is put on products.(20 products / 1 step)
Each product is to be placed on the FOAM SHEET with the LCD display surface facing upward, and FOAM SHEET is put on products.(40 products / tray)
- Step 2. Each tray filled with products is to be piled up in stack of 5. One empty tray is to be put on the top of stack of 5 trays.
- Step 3. 2 packs of moisture absorbers are to be placed on the top tray as shown in the drawing.
Put piled trays into a sealing bag.
- Step 4. Vacuum and seal the sealing bag with the vacuum sealing machine.
- Step 5. The piled trays are to be wrapped with a bubble cushioning sheet, and to be fixed with adhesive tape.
- Step 6. A corrugated board is to be placed in the bottom of an outer carton. The wrapped trays are to be put on the corrugated board in the outer carton.
- Step 7. The outer carton needs to sealed with packing tape as shown in the drawing.
The model number, quantity of products, and shipping date are to be printed on the outer carton.
If necessary, shipping labels or impression markings are to be put on the outer carton.
- Step 8. The outer carton is to be inserted into a extra outer carton with same direction.
The extra outer carton needs to sealed with packing tape as shown in the drawing.
- Step 9. The model number, quantity of products, and shipping date are to be printed on the extra outer carton.
If necessary, shipping labels or impression markings are to be put on the extra outer carton.

Packing item name	Specs, Material
① Tray	A-PET
② B SHEET A	Antistatic air bubble sheet
③ Inner board	Corrugated cardboard
④ Outer carton	Corrugated cardboard
⑤ Selling bag	
⑥ Drier	Moisture absorber
⑦ Extra outer carton	Corrugated cardboard
⑧ Packing tape	
⑨ FOAM SHEET	Antistatic Polyethylene

Dimension of extra outer carton	
D: Approx.	(337mm)
W: Approx.	(618mm)
H: Approx.	(179mm)
Quantity of products packed in one carton:	200
Gross weight : Approx.	5.0 kg

15. Handling Instruction

15.1 Cautions for Handling LCD panels



Caution

- (1) Do not make an impact on the LCD panel glass because it may break and you may get injured from it.
- (2) If the glass breaks, do not touch it with bare hands.
(Fragment of broken glass may stick you or you cut yourself on it.)
- (3) If you get injured, receive adequate first aid and consult a medial doctor.
- (4) Do not let liquid crystal get into your mouth.
(If the LCD panel glass breaks, try not let liquid crystal get into your mouth even toxic property of liquid crystal has not been confirmed.)
- (5) If liquid crystal adheres, rinse it out thoroughly.
(If liquid crystal adheres to your cloth or skin, wipe it off with rubbing alcohol or wash it thoroughly with soap.
If liquid crystal gets into eyes, rinse it with clean water for at least 15 minutes and consult an eye doctor.)
- (6) If you scrap this products, follow a disposal standard of industrial waste that is legally valid in the community, country or territory where you reside.
- (7) Do not connect or disconnect this product while its application products is powered on.
- (8) Do not attempt to disassemble or modify this product as it is precision component.
- (9) If a part of soldering part has been exposed, and avoid contact (short-circuit) with a metallic part of the case etc. about FPC of this model, please.
Please insulate it with the insulating tape etc. if necessary.
The defective operation is caused, and there is a possibility to generation of heat and the ignition.
- (10) Since excess current protection circuit is not built in this TFT module, there is the possibility that LCD module or peripheral circuit become feverish and burned in case abnormal operation is generated.
We recommend you to add excess current protection circuit to power supply.



Caution

This mark is used to indicate a precaution or an instruction which, if not correctly observed, may result in bodily injury, or material damages alone.

15.2 Precautions for Handling

- 1) Wear finger tips at incoming inspection and for handling the TFT monitors to keep display quality and keep the working area clean.
Do not touch the surface of the monitor as it is easily scratched.
- 2) Wear grounded wrist-straps and use electrostatic neutralization blowers to prevent static charge and discharge when handling the TFT monitors as the LED in this TFT monitors is damageable to electrostatic discharge.
Designate an appropriate operating area, and set equipment, tools, and machines properly when handling this product.
- 3) Avoid strong mechanical shock including knocking, hitting or dropping to the TFT monitors for protecting their glass parts.
Do not use the TFT monitors that have been experienced dropping or strong mechanical shock.
- 4) Do not use or storage the TFT monitors at high temperature and high humidity environment.
Particularly, never use or storage the TFT monitors at a location where condensation builds up.
- 5) Avoid using and storing TFT monitors at a location where they are exposed to direct sunlight or ultraviolet rays to prevent the LCD panels from deterioration by ultraviolet rays.
- 6) Do not stain or damage the contacts of the FPC cable .
FPC cable needs to be inserted until it can reach to the end of connector slot.
During insertion, make sure to keep the cable in a horizontal position to avoid an oblique insertion.
Otherwise, it may cause poor contact or deteriorate reliability of the FPC cable.
- 7) Do not bend or pull the FPC cable or carry the TFT monitor by holding the FPC cable.
Especially, it will cause mechanical damage or critical defect if FPC is pull up or bent up to short of display.

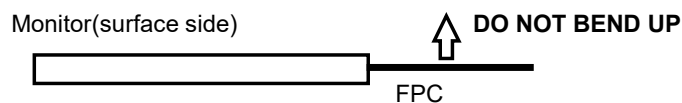

- 8) Peel off the protective film on the TFT monitors during mounting process.
Refer to the section 15.5 on how to peel off the protective film.
We are not responsible for electrostatic discharge failures or other defects occur when peeling off the protective film.
- 9) It is recommended to employ the structure of which polarizer peripheral area of LCD panel being pressed by cushioning materials, in order to prevent a cause of display brightness unevenness.

15.3 Precautions for Operation

- 1) Since this TFT monitors are not equipped with light shielding for the driver IC, do not expose the driver IC to strong lights during operation as it may cause functional failures.
- 2) In case of powering up or powering off this LCD module, be sure to comply the sequence as instructed in this specification.
- 3) Do not plug in or out the FPC cable while power supply is switch on.
Plug the FPC cable in and out while power supply is switched off.
- 4) Do not operate the TFT monitors in the strong magnetic field. It may break the TFT monitors.
- 5) Do not display a fixed image on the screen for a long time.
Use a screen-saver or other measures to avoid a fixed image displayed on the screen for a long time.
Otherwise, it may cause burn-in image on the screen due the characteristics of liquid crystal.

15.4 Storage Condition for Shipping Cartons

(Storage environment)

- Temperature 0 to 40° C
- Humidity 60%RH or less
No-condensing occurs under low temperature with high humidity condition.
- Atmosphere No poisonous gas that can erode electronic components and/or wiring materials should be detected.
- Time period 1 year
- Unpacking To prevent damages caused by static electricity, anti-static precautionary measures (e.g. earthing, anti-static mat) should be implemented.
After unpack, keep product in the appropriate condition, otherwise bubble seal of Protective film may be printed on Polarizer.
- Maximum piling up 8 cartons (excluding the bottom)

*Conditions to storage after unpacking

(Storage environment)

- Temperature 0 to 40° C
- Humidity 60%RH or less
No-condensing occurs under low temperature with high humidity condition.
- Atmosphere No poisonous gas that can erode electronic components and/or wiring materials should be detected.
- Time period 1 year (Shelf life)
- Others Keep/ store away from direct sunlight
Storage goods on original tray made by TOPPAN.

15.5 Precautions for Peeling off the Protective film

The followings work environment and work method are recommended to prevent the TFT monitors from static damage or adhesion of dust when peeling off the protective films.

A) Work Environment

- a) Humidity: 50 to 70 %RH, Temperature 15 to 27 ° C
- b) Operators should wear conductive shoes, conductive clothes, conductive finger tips and grounded wrist-straps.
Use an electrostatic neutralization blower.
- c) Anti-static treatment should be implemented to work area's floor.
Use a room shielded against outside dust with sticky floor mat laid at the entrance to eliminate dirt.

B) Work Method

The following procedures should taken to prevent the driver ICs from charging and discharging.

- a) Use an electrostatic neutralization blower to blow air on the TFT monitors to its lower right when FPC is placed at the bottom.
Optimize direction of the blowing air and the distance between the TFT monitors and the electrostatic neutralization blower.
- b) Put an adhesive tape (Scotch tape, etc) at the lower right corner area of the protective film to prevent scratch on surface of TFT monitors.
- c) Peel off the adhesive tape slowly (spending more than 2 secs to complete) by pulling it to opposite direction.

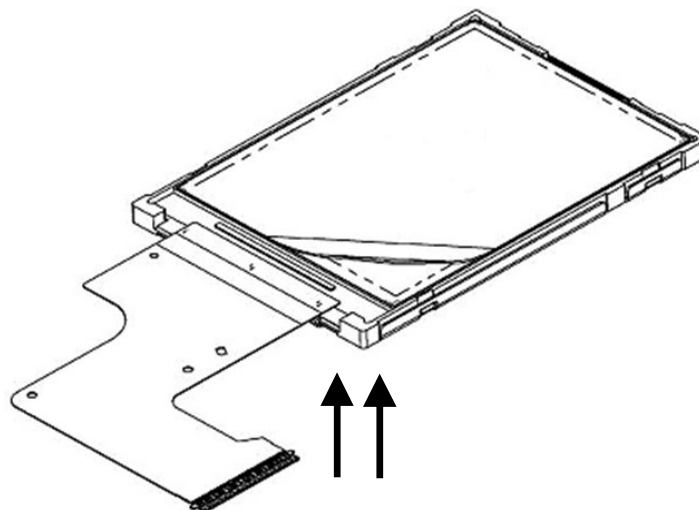

Blower wind direction
(Set an ion blower with its adequate conditions.)

15.6 Warranty

TOPPAN is only liable to defective goods which is stored and used under the condition complying with this specifications and returned within 1 (one) year.

Warranty caused by manufacturing defect shall be conducted by replacement of goods or refundment at unit price.

APPENDIX

Reference Method for Measuring Optical Characteristics and Performance

1. Measurement Condition

Measuring instruments: CS2000 (KONICA MINOLTA), LCD7200 (OTSUKA ELECTRONICS), EZcontrastXL88 (ELDIM)

Driving condition: Refer to the section "Optical Characteristics"

Measured temperature: 25°C unless specified

Measurement system: See the chart below. The luminance meter is placed on the normal line of measurement system.

Measurement point: At the center of the screen unless otherwise specified

Dark box at constant temperature

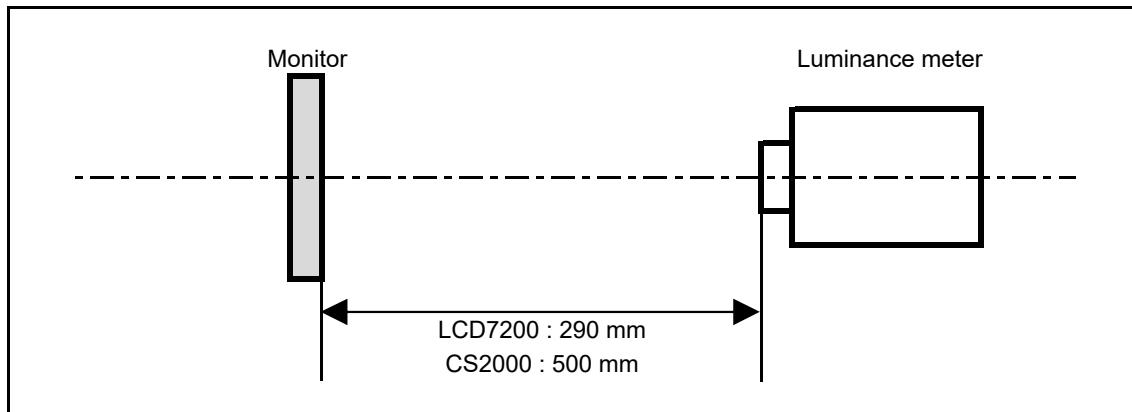

*Measurement is made after 30 minutes of lighting of the backlight.

Measurement point: At the center point of the screen

Brightness distribution: 9 points shown in the following drawing.

<Portrait model>

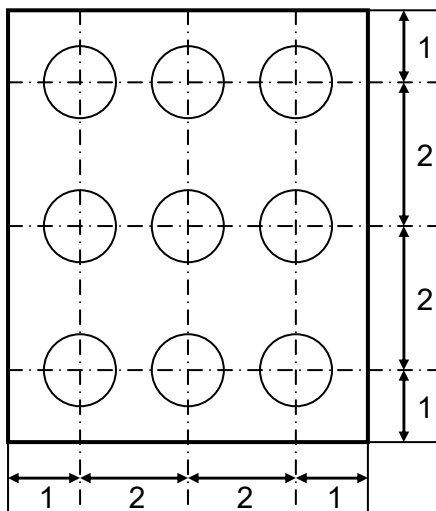

Dimensional ratio of active area

Backlight IL=10.0mA

2. Test Method

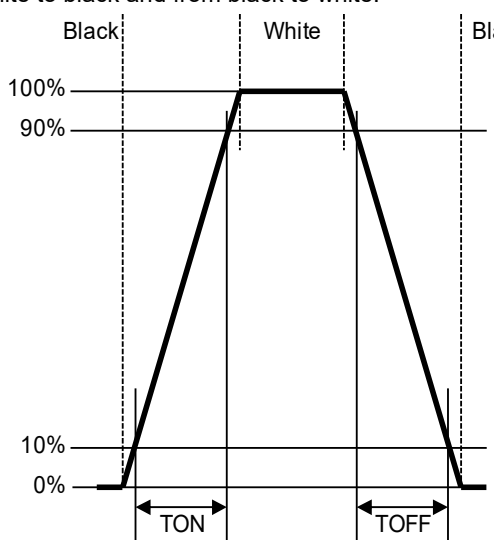
Notice	Item	Test method	Measuring instrument	Remark
1	Response time	<p>Measure output signal waveform by the luminance meter when raster of window pattern is changed from white to black and from black to white.</p> 	LCD7200	Black display [Data]=00h White display [Data]=3Fh TON Rise time TOFF Fall time
2	Contrast ratio	<p>Measure maximum luminance Y1([Data]=3Fh) and minimum luminance Y2([Data]=00h) at the center of the screen by displaying raster or window pattern. Then calculate the ratio between these two values.</p> <p>Contrast ratio = $Y1/Y2$</p> <p>Diameter of measuring point: 7.8mmφ(CS2000)</p>	CS2000	
3	Viewing angle Horizontalθ Verticalφ	Move the luminance meter from right to left and up and down and determine the angles where contrast ratio is 10.	EZcontrastXL88	
4	White chromaticity	<p>Measure chromaticity coordinates x and y of CIE1931 colorimetric system at [Data] = 3Fh</p> <p>Color matching function: 2°view measurement angle: 1°</p>	CS2000	
5	Center brightness	Measure the brightness at the center of the screen.	CS2000	
6	Brightness distribution	<p>(Brightness distribution) = $100 \times B/A \%$</p> <p>A : max. brightness of the 9 points B : min. brightness of the 9 points</p>	CS2000	
7	Burn-in	Visually check burn-in image on the screen after 2 hours of "window display" ([Data]=00h/3Fh).		At optimized VCOMDC