

# SPECIFICATION

<b>CUSTOMER</b>	
<b>PRODUCT P/N</b>	<b>UDDD-S020280-AHRSBW</b>
<b>TYPE</b>	<b>0.28" Two Digits SMD Display Hyper Red Common Anode Black Face / White Segment</b>

## ■ RECORD OF REVISION

<b>Version</b>	<b>Date</b>	<b>Page</b>	<b>Description</b>
0.0	2016/02/17	All	New document

## ■ FEATURES

Connecting Form: Common Anode  
Lighting Color: Hyper Red

## ■ ELECTRICAL OPTICAL CHARACTERISTICS (Ta = 25°C):

Parameter	Symbol	Min	Type	Max	Unt	Test Condition
Luminous Intensity	IV	10	20		mcd	IF=20mA
Peak Wavelength	$\lambda_p$		632		nm	IF=20mA
Dominant Wavelength	$\lambda_d$		624		nm	IF=20mA
Spectrum Line Half-Width	$\Delta\lambda$		20		nm	IF=20mA
Forward Voltage	Vf	1.9		2.5	V	IF=20mA
Reverse Current	IR			100	uA	V <sub>R</sub> =5V
Suggestion Forward Current	IF	3	5-10	20	mA	IF=20mA

## ■ ABSOLUTE MAXIMUM RATINGS (Ta=25°C)

Parameter	Rating	Unit
Reverse Voltage	5	V
Power Dissipation Per Dice	60	mW/chip
Operating Temperature Ranger	-40~+80	°C
Storage Humidity	45%~85%	RH
Storage Temperature Ranger	-40~+85	°C
Soldering Temperature	260±5°C	For 3 Seconds
Peak IF(ma) (1/10Duty Cycle 0.1ms Pulse Width)	100	mA/chip
Continuous Forward Current	25	mA/chip

## ■ SUGGESTED WAY OF USAGE

When using LED it's circuit adopts current limiting with DC current about 5~10mA, not more than 25mA at maximum

■ FRONT VIEW



■ PACKAGE DIMENSION

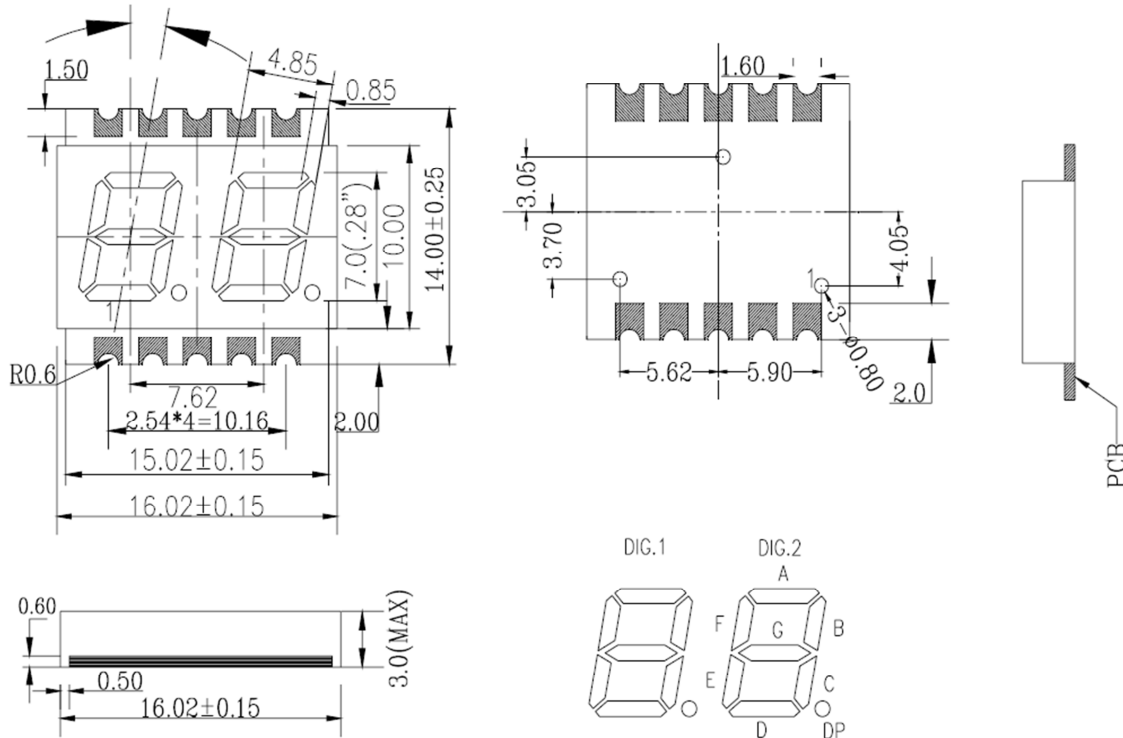

■ INTERNAL CIRCUIT DIAGRAM AND SEGMENT POSITION

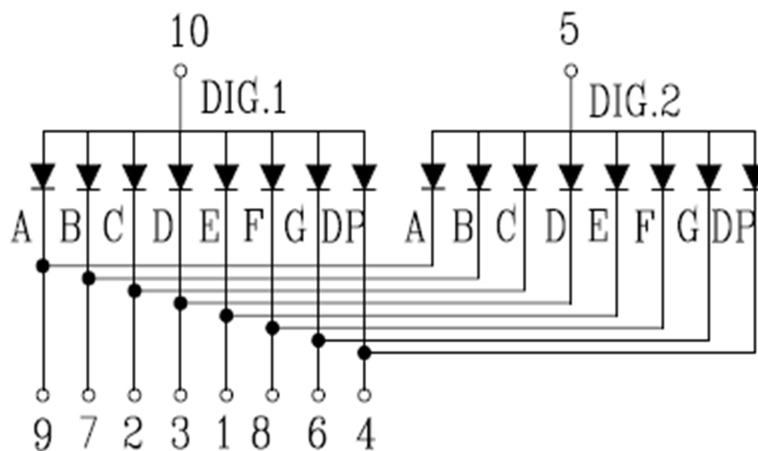

Notes:

- a. All dimensions are in millimeters
- b. Tolerance are  $\pm 0.25\text{mm}$  unless otherwise noted

■ PRECAUTIONS FOR USE

1) Recommended Soldering conditions Wave Soldering

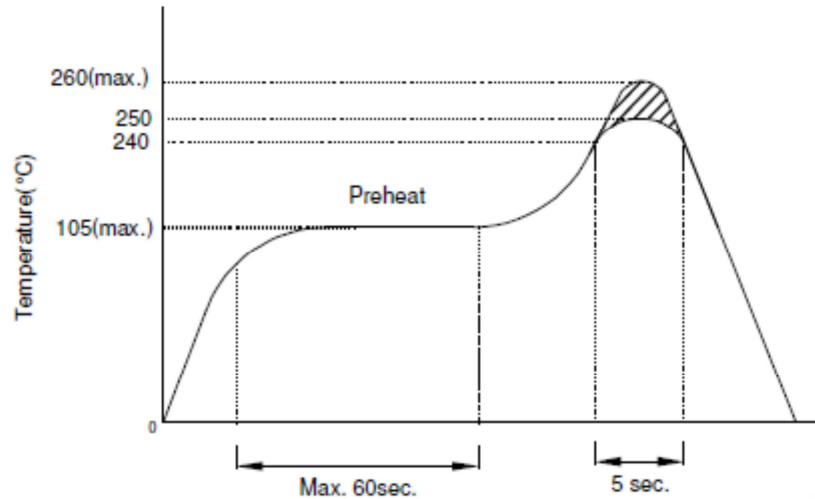

2) Soldering Iron

Basic SPEC. Is ≤ 5sec. When 260°C. If temperature is higher, time should be shorter (+10 °C → 1 sec.)

Power dissipation of iron should be smaller than 15W, and temperature should be controllable.

Surface temperature of the device should be under 230°C

3) Rework :

1. Customer must finish rework within 5 sec under 260°C
2. The head of iron cannot touch copper foil.

■ Soldering Pad Size

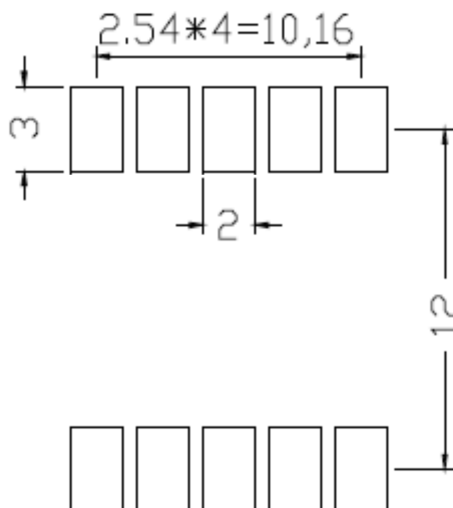

**■ TYPICAL OPTICAL/ELECTRICAL CHARACTERISTICS CURVES**  
 (Ta=25°C Unless Otherwise Noted)

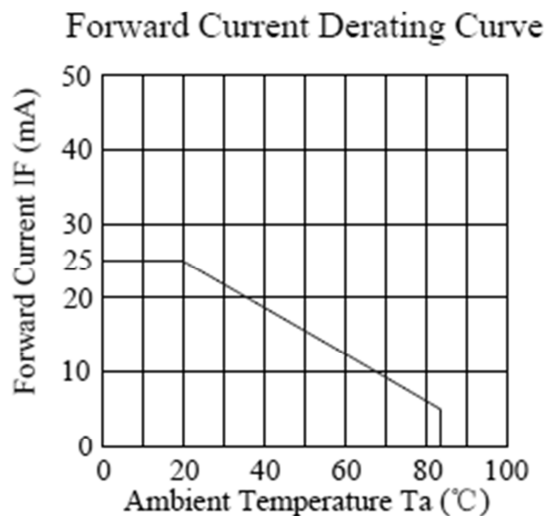
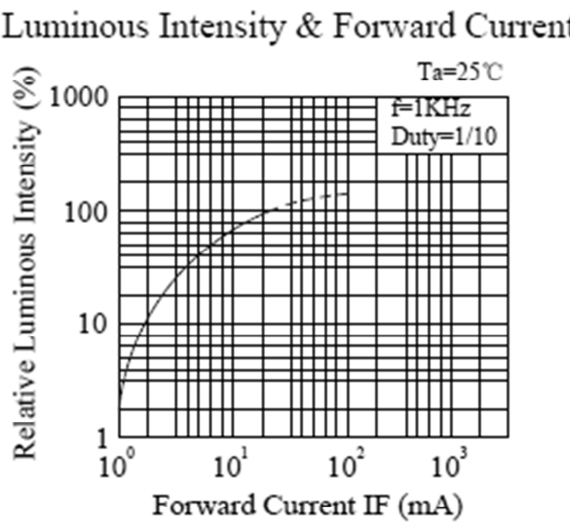
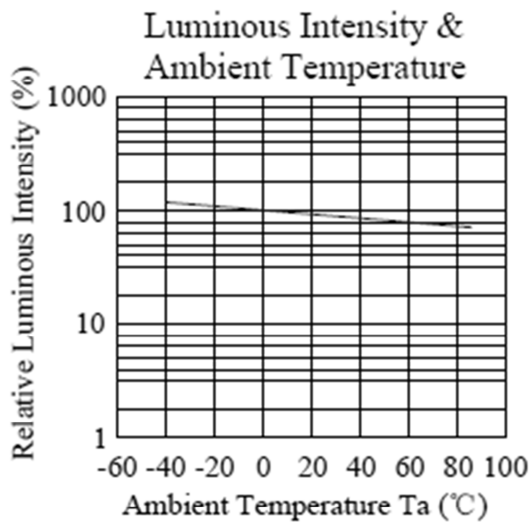
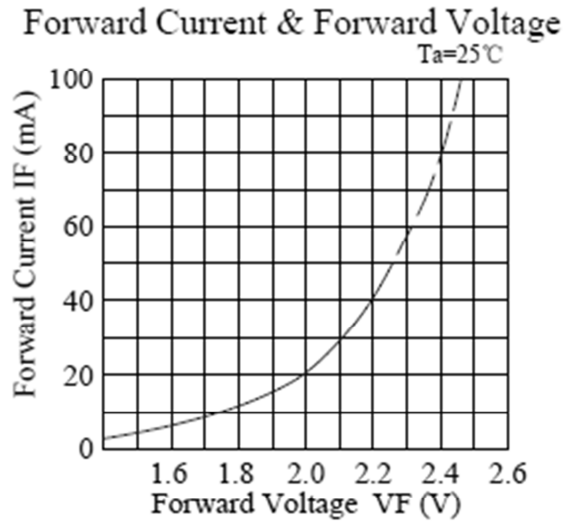
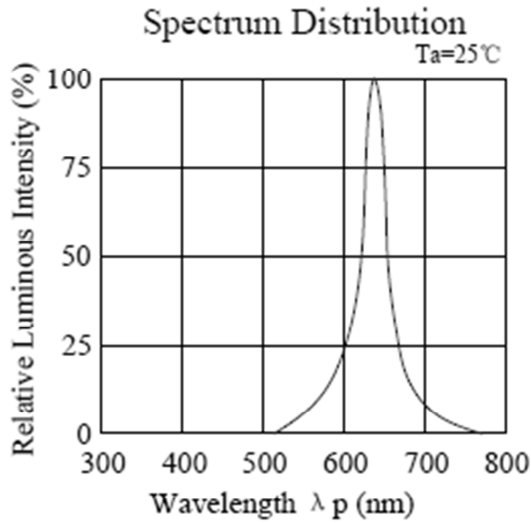

■ PACKAGE INFORMATION

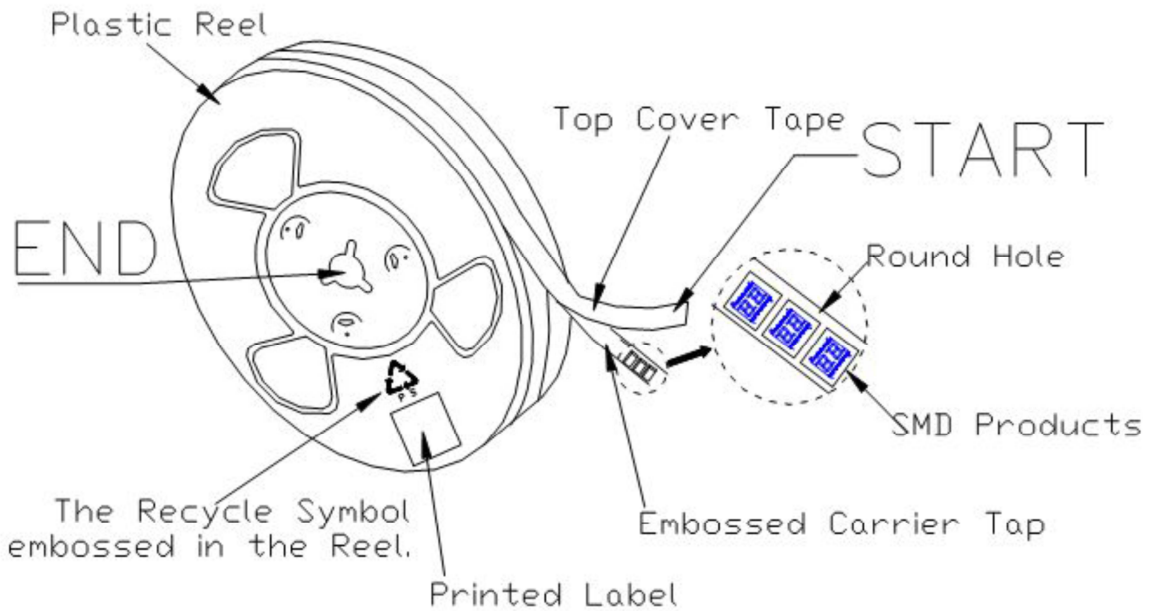

Tape Dimensions:  
Total unit per reel is 700PCS.

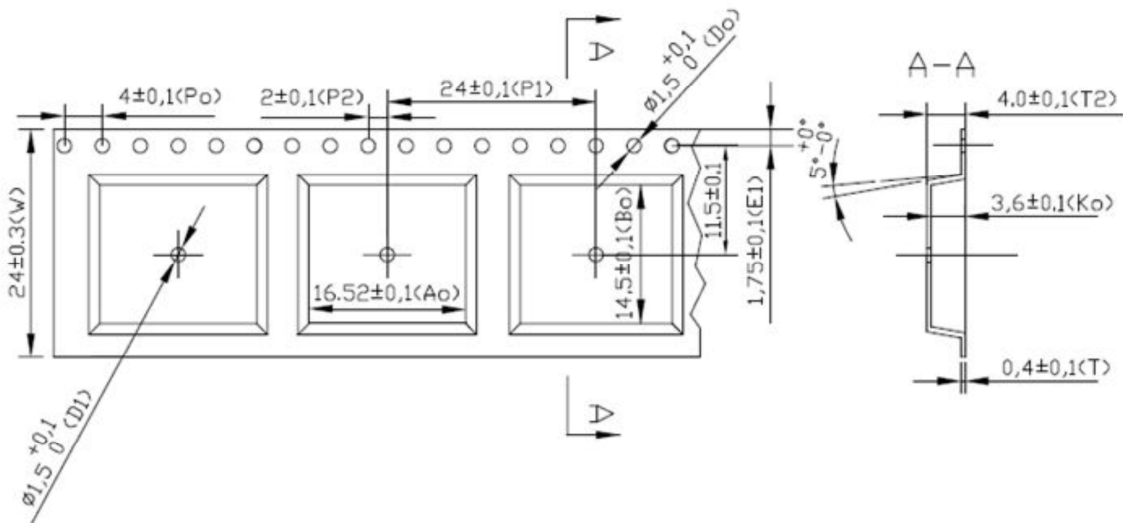

**■ PLEASE READ THE FOLLOWING NOTES BEFORE USING THE PRODUCT:**

1. Over-current-proof

Customer must apply resistors for protection, otherwise slight voltage shift will cause big current change (Burn out will happen).

2. Storage

2.1 Do not open moisture proof bag before the products are ready to use.

2.2 Before opening the package, the LEDs should be kept at 30°C or less and 80%RH or less.

2.3 The LEDs should be used within a year.

2.4 After opening the package, the LEDs should be kept at 30°C or less and 60%RH or less.

2.5 The LEDs should be used within 168 hours (7 days) after opening the package.

3. Soldering Iron

Each terminal is to go to the tip of soldering iron temperature less than 260°C for 5 seconds within once in less than the soldering iron capacity 25W. Leave two seconds and more intervals, and do soldering of each terminal. Be careful because the damage of the product is often started at the time of the hand solder.

4. Soldering

When soldering, for Lamp without stopper type and must be leave a minimum of 3mm clearance from the base of the lens to the soldering point.

To avoided the Epoxy climb up on lead frame and was impact to non-soldering problem, dipping the lens into the solder must be avoided.

Do not apply any external stress to the lead frame during soldering while the LED is at high temperature.

Recommended soldering conditions:

Soldering Iron		Wave Soldering	
Temperature	300°C Max.	Pre-heat	100°C Max.
Soldering Time	3 sec. Max. (one time only)	Pre-heat Time	60 sec. Max.
		Solder Wave	260°C Max.
		Soldering Time	5 sec. Max.

\*Note: Excessive soldering temperature and / or time might result in deformation of the LED lens or catastrophic failure of the LED.

5. Repairing

Repair should not be done after the LEDs have been soldered. When repairing is unavoidable, a double-head soldering iron should be used. It should be confirmed beforehand whether the characteristics of the LEDs will or will not be damaged by repairing.

6. Caution in ESD

Static Electricity and surge damages the LED. It is recommended to use a wrist band or anti-electrostatic glove when