

Dept	Qty
DC	1
ED	1
IE	1
ISO	1
PD	1
R&D	1
SD	1
QA	1
QC	1
QF	1

The information provided herein is from CONNELY Electronic Co., Ltd. and is confidential. Any disclosure to a party other than the recipient is prohibited. The intellectual properties and its rights contained herein, including but not limited to, trademarks, patents, copyrights, trade secrets, and technical know-how, are owned exclusively by CONNELY or its affiliates. Unauthorized use or reproduction of any part of this document is strictly prohibited. CONNELY may enforce its intellectual property rights at its own discretion, failures or delays to exercise such rights does not constitute a waiver of such rights.

Dimension

Position	A±0.2	B±0.2	C±0.3
9	17.90	24.99	30.80
15	26.50	33.32	39.14
25	40.00	47.04	53.04
37	56.50	63.50	69.32

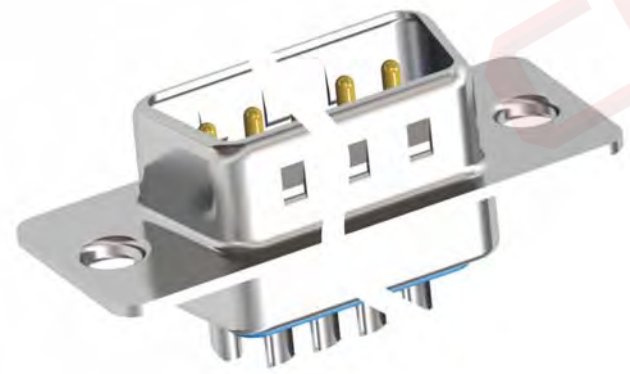
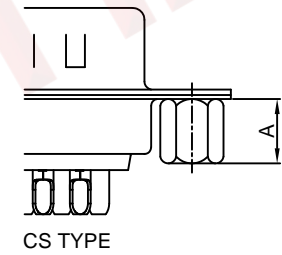
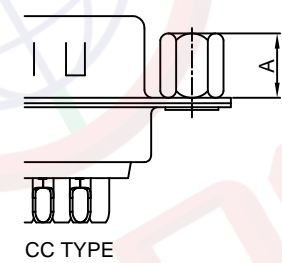
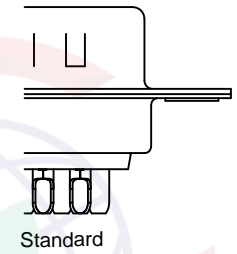
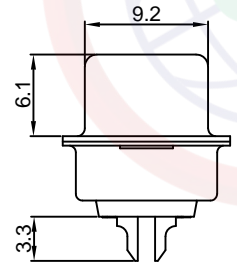
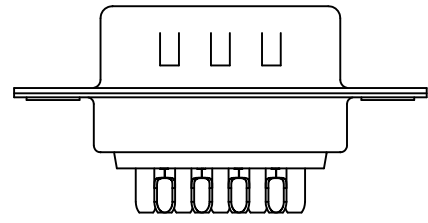
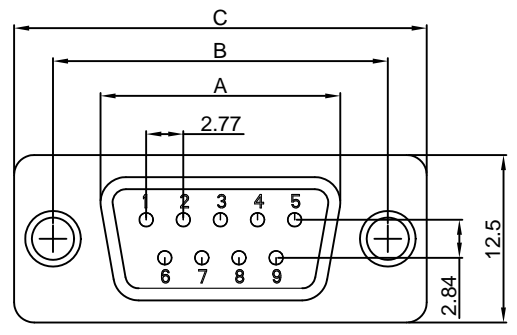

(Series Image-Reference Only)

REV.	DESCRIPTION	DRAWN	CHECKED	APPROVED
A	NEW RELEASE	YCH 08/27/10'		LJC 08/27/10'
B	DRAWING UPDATE	JLZ 08/31/20'		

NOTES:

- Electrical characteristics:
 - Contact resistance: 20mΩ Max. Initial.
 - Dielectric withstanding voltage: 500V AC(rms) for 1 minute.
 - Insulation resistance: 1000MΩ Min.
- Environment characteristics:
 - Temperature range: -40°C~+105°C.
- Materials:
 - Insulator:PBT+Glass fiber
 - Shell:Steel
 - Contact:Copper alloy

4. Product number code:

DS1033-10- X X X X X X X

- Screw DIM. A
 - S: Standard(W/O nut)
 - 1: 5.00 2: 3.00
 - 3: 5.20 4: 4.80
 - 5: 5.80 6: 4.00
- Screw type
 - S: Standard(W/O nut)
 - 1: CC type
 - 2: CS type
- Contact plating
 - 6: Full tin 8: Full gold flash
 - 0: Selective gold flash
 - J: Selective 5u" gold
- Shell plating
 - T: Front & Back Tin
 - N: Front Nickel,Back Tin
- Housing color
 - B: Black W: White
 - U: Blue
- Connector type
 - M: Male
- No.of contacts
 - 09,15,25,37

GENERAL TOLERANCE		ANGLE TOLERANCE	
X.	±0.60	X.	±5°
.X	±0.38	.X	±3°
.XX	±0.25	.XX	±2°
DRAWING TYPE		CUSTOMER	
SCALE	1:1	SHEET	1 OF 1
DRAWING NO.	C-DS1033-10-XXXXXX-B		

PROJECTION		TITLE	D-SUB MALE SOLDER TYPE
UNITS	mm	2 INSULATOR TYPE	
SHEET SIZE	A4	SERIES	DS1033-10 SERIES

晨翔电子有限公司
CONNFLY CONNELY ELECTRONIC CO. LTD