



**RAYSTAR**

# 曜凌光電股份有限公司

住址: 42878 台中市大雅区科雅路 25 號 5F WEB: <http://www.Raystar-Optronics.com>  
5F., No.25, Keya Rd., Daya Dist., Taichung E-mail: [sales@raystar-optronics.com](mailto:sales@raystar-optronics.com)  
City 428, Taiwan Tel:886-4-2565-0761 Fax : 886-4-2565-0760

## RFP620A-6XW-DNN

---

---

### SPECIFICATION

CUSTOMER:

APPROVED BY	
PCB VERSION	
DATE	

FOR CUSTOMER USE ONLY

SALES BY	APPROVED BY	CHECKED BY	PREPARED BY

Release DATE:

## Revision History

VERSION	DATE	REVISED PAGE NO.	Note
0	2015/10/14		First issue
A	2016/01/21		Modify Static electricity test

RAYSTAR OPTRONICS

# Contents

- 1.Module Classification Information
- 2.Summary
- 3.General Specification
- 4.Interface
- 5.Contour Drawing
- 6.Block Diagram
- 7.Absolute Maximum Ratings
- 8.Electrical Characteristics
- 9.DC Characteristics
- 10.AC Characteristics
- 11.Optical Characteristics
- 12.Reliability
- 13.Package Specification
- 14.Initial Code For Reference
- 15.Other

# 1.Module Classification Information

<b>R</b>	<b>F</b>	<b>P</b>	<b>62</b>	<b>0A</b>	<b>-</b>	<b>6</b>	<b>X</b>	<b>W</b>	<b>-</b>	<b>D</b>	<b>N</b>	<b>N</b>
1	2	3	4	5	-	6	7	8	-	9	10	11

<b>Item</b>	<b>Description</b>	
1	R : Raystar Optronics Inc.	
2	Display Type : F→TFT Type, J→ Custom TFT	
3	Solution: A: 128x160    B:320x234    C:320x240    D:480x234    E:480x272 F:800x480    G:640x480    H:1024x600    I:320x480    J:240x320 K:1280x800    L:240x400    M:1024x768    N:128x128    O:480x800 P:640x320    Q:800x600    S:480x128    T:800x320	
4	Display Size : 6.2" TFT	
5	Version Code.	
6	Model Type: A : TFT LCD E : TFT+FR+CONTROL BOARD J : TFT+FR+A/D BOARD N : TFT+FR+A/D BOARD+CONTROL BOARD S : TFT+FR+POWER BOARD (DC TO DC) 1 : TFT+CONTROL BOARD	6 : TFT+FR H : TFT+D/V BOARD I : TFT+FR+D/V BOARD B : TFT+POWER BD
7	Polarizer Type, Temperature range, View direction	I→Transmissive, W. T, 6:00 ; C→Transmissive, N. T, 6:00 L→Transmissive, W.T,12:00 ; F→Transmissive, N.T,12:00 Y→Transmissive,W.T, IPS TFT ; A→Transmissive, N.T, IPS TFT Z→Transmissive, W.T, O-TFT R→Transmissive, Super W.T, O-TFT N→Transmissive, Super W.T, 6:00; Q→Transmissive, Super W.T, 12:00 V→Transmissive, Super W.T, VA TFT
8	Backlight	W : LED, White    H : LED, High Light White F : CCFL, White
9	Driver Method	D: Digital    A: Analog    L : LVDS    M:MIPI
10	Interface	N : without control board    A : 8Bit    B : 16Bit S:SPI Interface    R: RS232    U:USB    I: I2C
11	TS	N : Without TS    S : resistive touch panel C : capacitive touch panel capacitive touch panel (G-F-F) G : capacitive touch panel(G-G)

## 2.Summary

This technical specification applies to 6.2' Mono TFT-LCD panel. The 6.2' Mono TFT-LCD panel is designed for camcorder, digital camera application and other electronic products which require high quality flat panel displays. This module follows RoHS.

RAYSTAR OPTRONICS

---

### 3.General Specifications

- Size: 6.2 inch
- Dot Matrix: 640 x 320 dots
- Module dimension: 170.32 x 88.3 x 5.3 mm
- Active area: 140 x 70 mm
- Dot pitch: 0.21875 x 0.21875 mm
- LCD type: TFT, Normally Black, Transmissive
- View Direction: Wide View
- Gray Scale: 16 Gray scale (4BPP)/ 4 Gray scale (2BPP)/ 2 Gray scale (1BPP)
- Controller IC: ST7511U
- Backlight Type: LED, Normally White
- With /Without TP: Without TP
- Surface: Glare

\* Mono tone slight changed by temperature and driving voltage.

## 4.Interface

### 4.1. LCM PIN Definition

Pin	Symbol	Function	Remark
1	GND	System ground	
2	VDD	Power Supply : +3.3V	
3	NC	No connect	
4	A0	Data/Command select	
5	/WR(R/W)	Write strobe signal	
6	/RD(E)	Read strobe signal	
7	DB0	Data bus	
8	DB1	Data bus	
9	DB2	Data bus	
10	DB3	Data bus	
11	DB4	Data bus	
12	DB5	Data bus	
13	DB6	Data bus	
14	DB7	Data bus	
15	/CS	Chip select	
16	/RESET(RSTB)	Hardware reset	
17	IF0	Mode select	Note1
18	IF1		
19	NC	No connect	
20	NC	No connect	
21	NC	No connect	
22	NC	No connect	

Note1:

Setting		MCU Type	Interface Pin Function				
IF1	IF0		CSB	A0	RWR	ERD	D[7:0]
L	L	Parallel 8080 series MCU	CSB	A0	/WR	/RD	D[7:0]
L	H	Parallel 6800 series MCU			R/W	E	D[7:0]
H	H	Serial 4-Line series MCU			-	-	D7=SCL, D0=SDA, D[6:1] are not used
H	L	Serial 3-Line series MCU			-	-	

The un-used pins are marked as “-” and should be connected to “H” by VDDI.

### 4.2. Backlight Unit Section(CN2)

LED Light Bar connector is used for the the integral backlight system. The recommended model is “JST XH-3” manufactured by JST.

Pin No.	Symbol	I/O	Function	Remark
1	V <sub>LED+</sub>	P	Power for LED backlight anode (A)	Red
3	V <sub>LED-</sub>	P	Power for LED backlight cathode (K)	Black

# 5. Contour Drawing

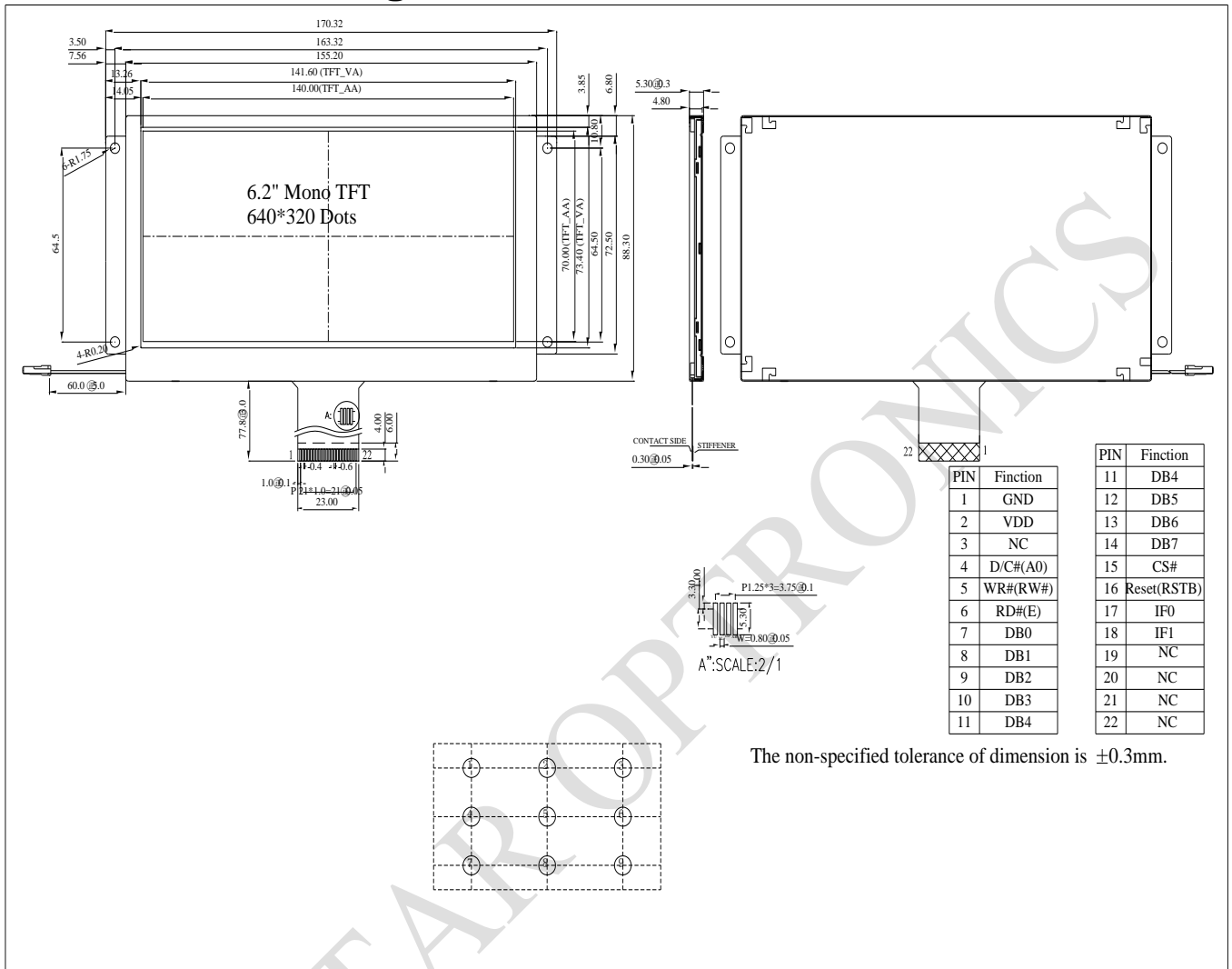



## 6. Block Diagram

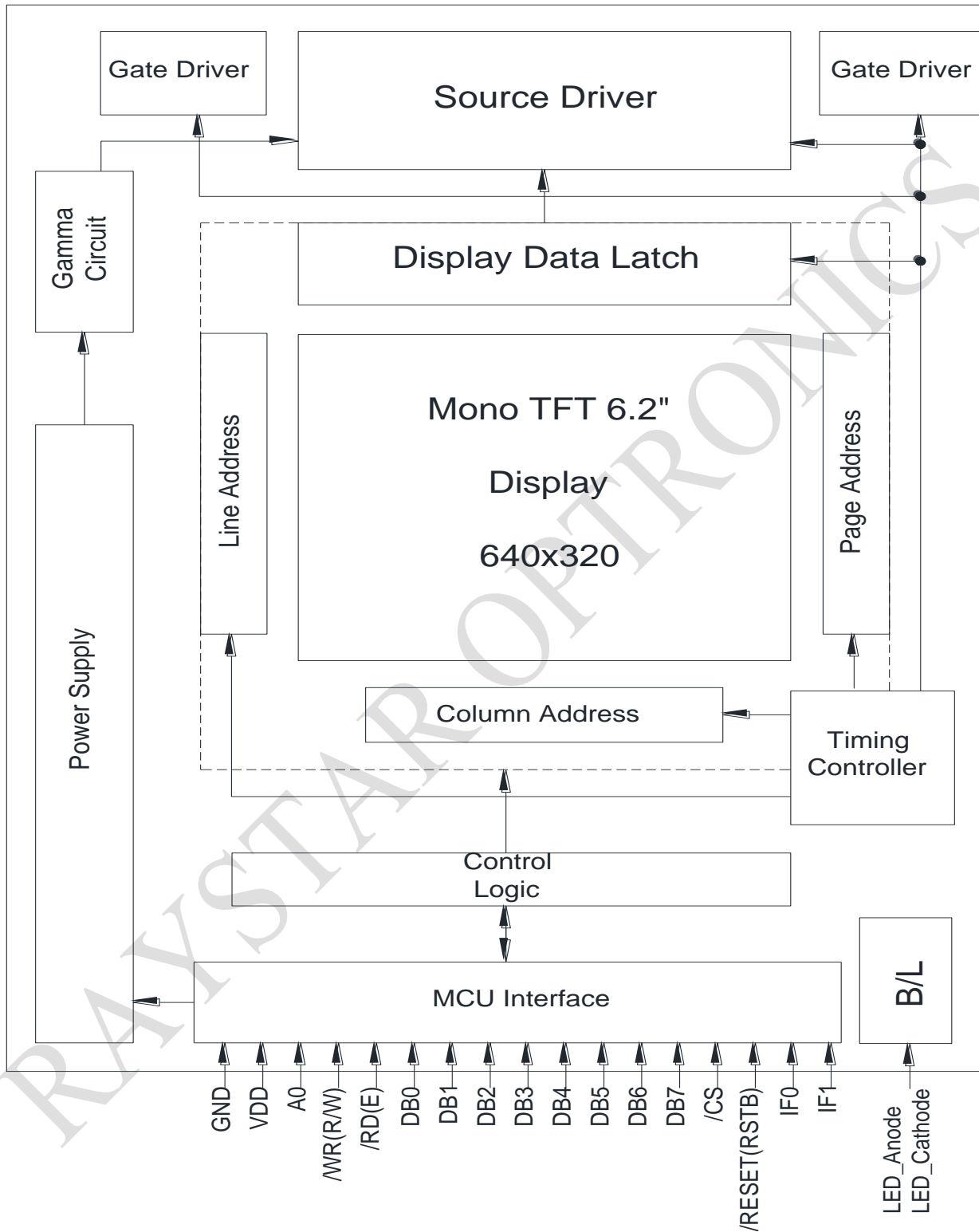

## 7. Absolute Maximum Ratings

Item	Symbol	Min	Typ	Max	Unit
Operating Temperature	TOP	-20	—	+70	°C
Storage Temperature	TST	-30	—	+80	°C

Note: Device is subject to be damaged permanently if stresses beyond those absolute maximum ratings listed above

- Temp.  $\leq 60^{\circ}\text{C}$ , 90% RH MAX. Temp.  $> 60^{\circ}\text{C}$ , Absolute humidity shall be less than 90% RH at  $60^{\circ}\text{C}$

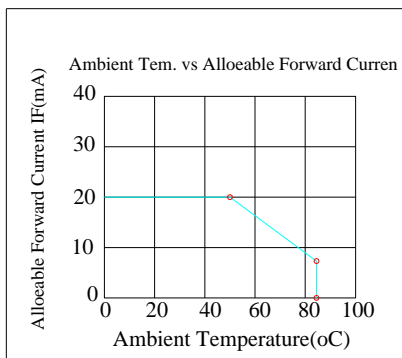

## 8. Electrical Characteristics

### 8.1. Operating conditions:

Item	Symbol	Condition	Min	Typ	Max	Unit	Remark
Supply Voltage For LCM	VDD	—	3.0	3.3	3.6	V	
Supply Current For LCM	IDD	—	—	25	38	mA	Note1
Power Consumption	—	—	—	83	137	mW	

Note1: This value is test for VDD=3.3V only

### 8.2. LED driving conditions

Parameter	Symbol	Min.	Typ.	Max.	Unit	Remark
LED current		-	160	-	mA	
Power Consumption		1392	-	1680	mW	
LED voltage	A-K	8.7	9.6	10.5	V	Note 1
LED Life Time		-	20,000	-	Hr	Note 2,3,4

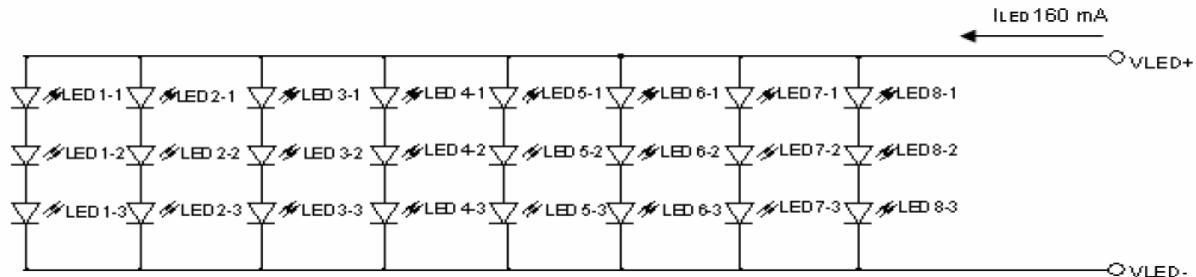

Note 1 : Power supply the back light specification

Note 2 : Ta = 25 °C

Note 3 : Brightness to be decreased to 50% of the initial value

Note 4 : The single LED lamp case

## 9.DC CHARATERISTICS

Parameter	Symbol	Rating			Unit	Condition
		Min	Typ	Max		
Low level input voltage	$V_{IL}$	0	-	0.3VDD	V	
High level input voltage	$V_{IH}$	0.7VDD	-	VDD	V	

RAYSTAR OPTRONICS

# 10.AC CHARATERISTICS

## 10.1. System Bus Timing for 6800 Series MPU

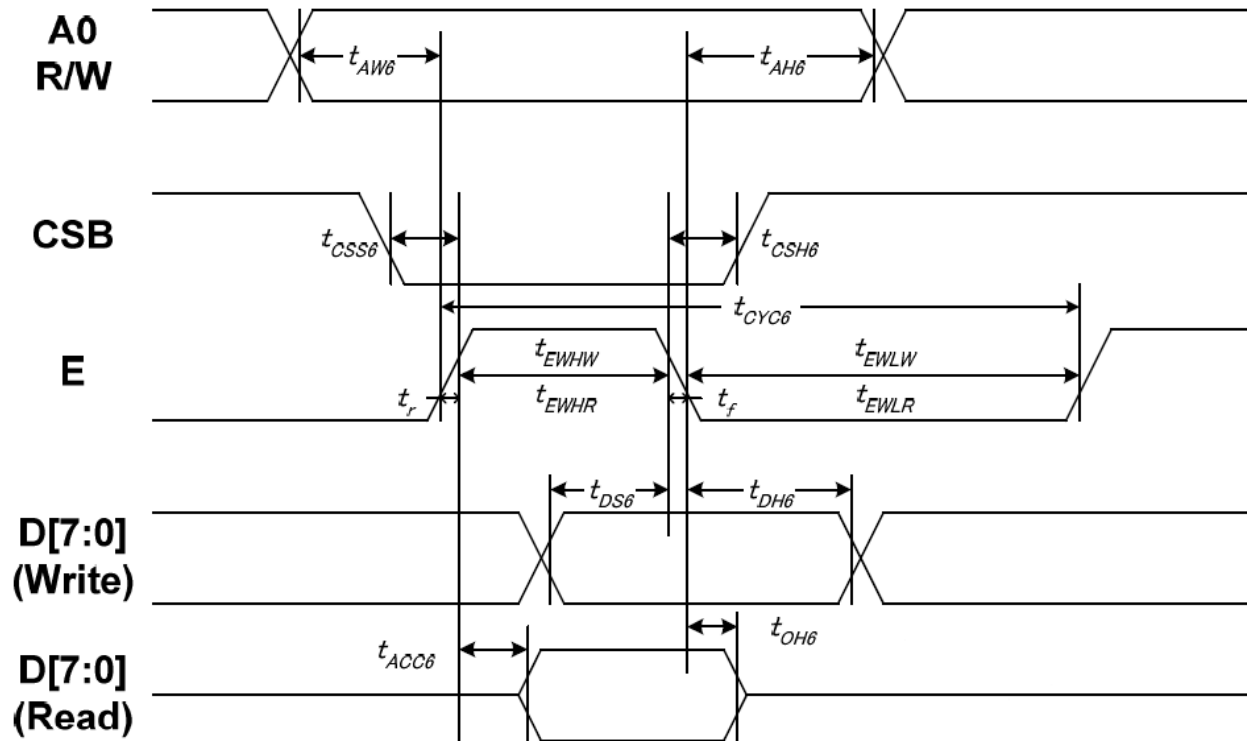

Item	Signal	Symbol	Condition	Min	Max	Unit
Address setup time	A0	$t_{AW6}$	-	10	-	ns
Address hold time		$t_{AH6}$	-	0	-	
System cycle time		$t_{CYC6}$	-	200	-	
Enable L pulse width (WRITE)	E	$t_{EHLW}$	-	100	-	
Enable H pulse width (WRITE)		$t_{EWHW}$	-	100	-	
Enable L pulse width (READ)		$t_{EHLR}$	-	130	-	
Enable H pulse width (READ)		$t_{EWHR}$	-	130	-	
CSB setup time	CSB	$t_{CSS6}$	-	100	-	
CSB hold time		$t_{CSH6}$	-	100	-	
Write data setup time	D[7:0]	$t_{DS6}$	-	70	-	
Write data hold time		$t_{DH6}$	-	20	-	
Read data access time		$t_{ACC6}$	CL = 100 pF	-	80	
Read data output disable time		$t_{OH6}$	CL = 100 pF	15	80	

**Note:**

1. The input signal rise time and fall time ( $t_r$ ,  $t_f$ ) is specified at 15 ns or less. When the system cycle time is extremely fast,  $(t_r + t_f) \leq (t_{CYC6} - t_{CCLW} - t_{CCHW})$  for  $(t_r + t_f) \leq (t_{CYC6} - t_{CCLR} - t_{CCHR})$  are specified.
2. All timing is specified using 20% and 80% of VDDI as the reference.
3.  $t_{CCLW}$  and  $t_{CCLR}$  are specified as the overlap between CSB being "L" and /WR and /RD being at the "L" level. CSB and /WR (or /RD) cannot act at the same time and CSB should be 100ns wider than /WR (or /RD).

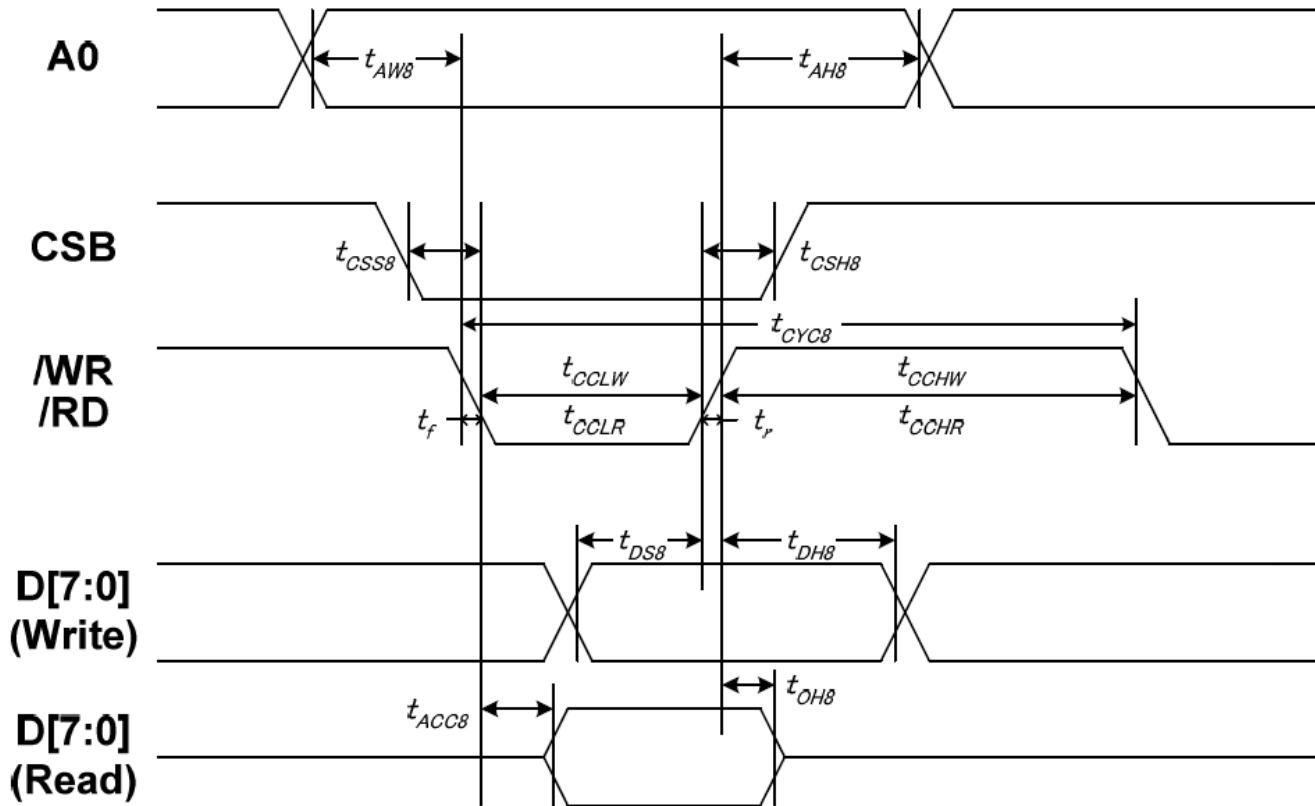
**10.2. System Bus Timing for 8080 Series MPU**

Item	Signal	Symbol	Condition	Min	Max	Unit
Address setup time	A0	tAW8	-	10	-	ns
Address hold time		tAH8	-	0	-	
System cycle time		tCYC8	-	200	-	
/WR L pulse width (WRITE)	/WR	tCCLW	-	100	-	
/WR H pulse width (WRITE)		tCCHW	-	100	-	
/RD L pulse width (READ)	/RD	tCCLR	-	120	-	
/RD H pulse width (READ)		tCCHR	-	120	-	
CSB setup time	CSB	tCSS8	-	100	-	
CSB hold time		tCSH8	-	100	-	
Write data setup time	D[7:0]	tDS8	-	70	-	
Write data hold time		tDH8	-	20	-	
Read data access time	D[7:0]	tACC8	CL = 100 pF	-	80	
Read data output disable time		tOH8	CL = 100 pF	15	80	

**Note:**

- The input signal rise time and fall time ( $t_r$ ,  $t_f$ ) is specified at 15 ns or less. When the system cycle time is extremely fast,  $(t_r + t_f) \leq (t_{CYC8} - t_{CCLW} - t_{CCHW})$  for  $(t_r + t_f) \leq (t_{CYC8} - t_{CCLR} - t_{CCHR})$  are specified.
- All timing is specified using 20% and 80% of VDDI as the reference.
- $t_{CCLW}$  and  $t_{CCLR}$  are specified as the overlap between CSB being "L" and /WR and /RD being at the "L" level. CSB and /WR (or /RD) cannot act at the same time and CSB should be 100ns wider than /WR (or /RD).

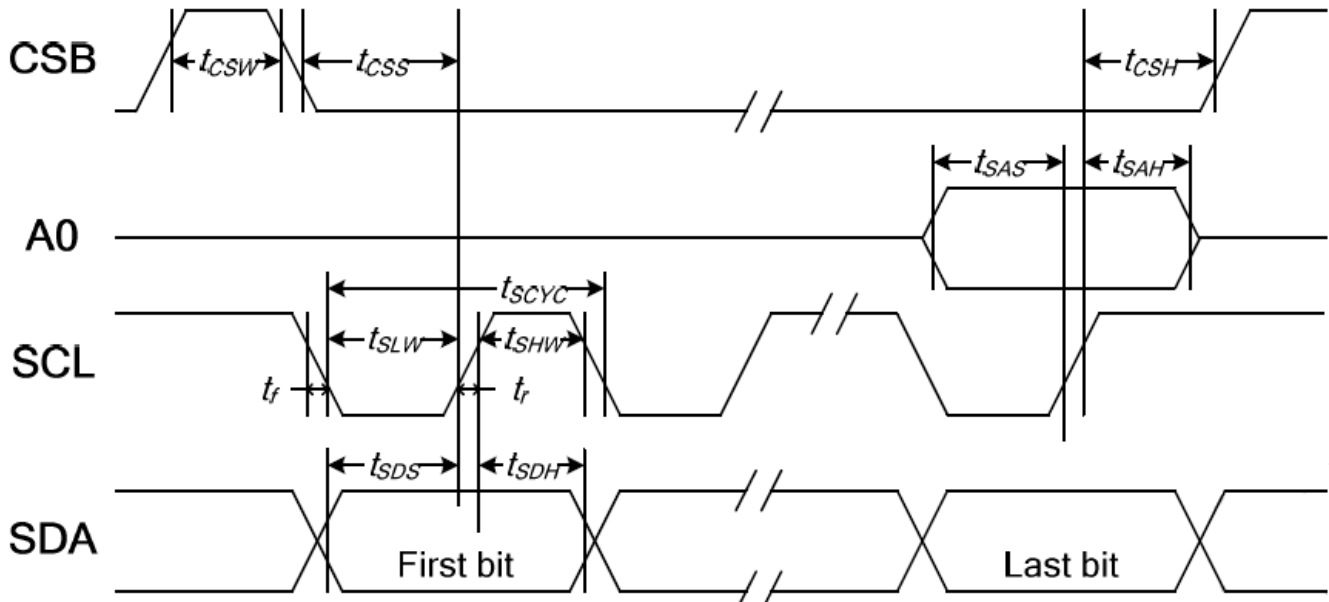
**10.3. System Bus Timing for 4-Line Serial Interface**

Item	Signal	Symbol	Condition	Min	Max	Unit
Serial clock period	SCL	tSCYC	-	80	-	ns
SCL "H" pulse width		tSHW	-	40	-	
SCL "L" pulse width		tSLW	-	40	-	
Address setup time	A0	tSAS	-	40	-	
Address hold time		tSAH	-	40	-	
Data setup time	SDA	tSDS	-	15	-	
Data hold time		tSDH	-	20	-	
CSB-SCL time	CSB	tCSS	-	40	-	
CSB-SCL time		tCSH	-	40	-	
CSB "H" pulse width		tCSW	-	15	-	

Note:

1. The input signal rise and fall time ( $t_r$ ,  $t_f$ ) are specified at 15 ns or less.
2. All timing is specified using 20% and 80% of VDDI as the standard.

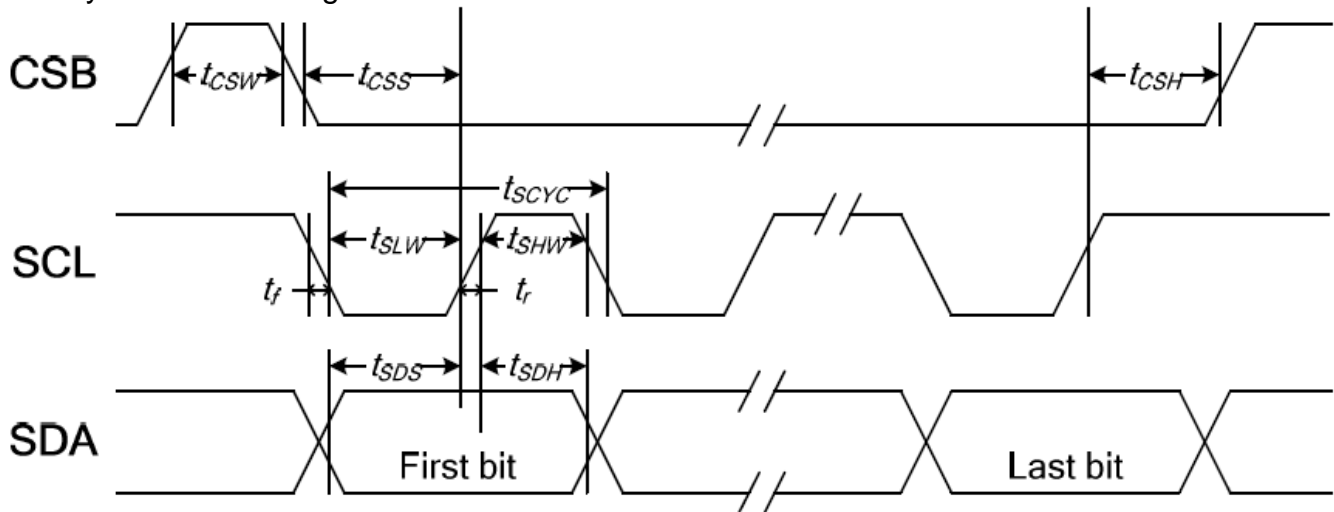
**10.4. System Bus Timing for 3-Line Serial Interface**

Item	Signal	Symbol	Condition	Min	Max	Unit
Serial clock period		tSCYC	-	80	-	ns
SCL "H" pulse width	SCL	tSHW	-	40	-	
SCL "L" pulse width	SCL	tSLW	-	40	-	
Data setup time	SDA	tSDS	-	15	-	
Data hold time	SDA	tSDH	-	20	-	
CSB-SCL time		tCSS	-	40	-	
CSB-SCL time	CSB	tCSH	-	40	-	
CSB "H" pulse width	CSB	tCSW	-	15	-	

**Note:**

1. The input signal rise and fall time ( $t_r$ ,  $t_f$ ) are specified at 15 ns or less.
2. All timing is specified using 20% and 80% of VDDI as the standard.



# 11. Optical Characteristics

Item	Symbol	Temp	Condition.	Min	Typ.	Max.	Unit	Remark
Response time	Tr	25°C	$\theta=0^\circ$ 、 $\phi=0$	-	8	-	.ms	Note 3
	Tf	25°C		-	12	-		
Contrast ratio	CR	25°C	At optimized viewing angle	-	800	-	-	Note 4
Viewing angle (Gray Scale Inversion Direction)	Hor.	$\Theta_R$	25°C	CR $\geq$ 10	80		Deg.	Note 1 Note 2
		$\Theta_L$	25°C		80			
	Ver.	$\Phi_B$	25°C		80			
		$\Phi_T$	25°C		80			
Brightness	-	25°C	-	500	600	-	cd/m <sup>2</sup>	Center of display

Ta=25±2°C, IL=160mA

Note 1: Definition of viewing angle range

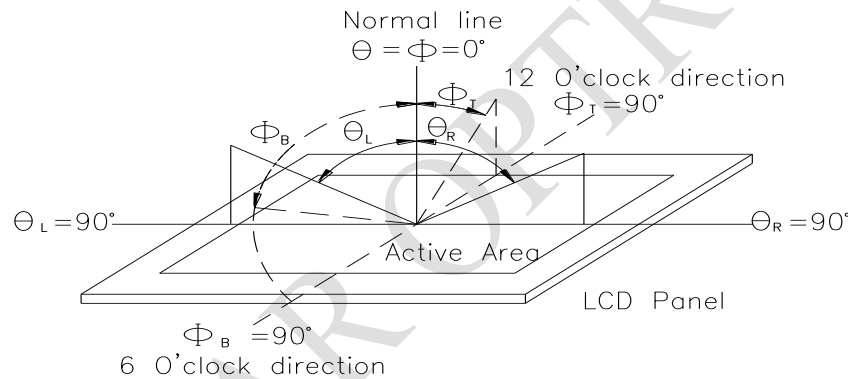

Fig.11.1. Definition of viewing angle

Note 2: Test equipment setup:

After stabilizing and leaving the panel alone at a driven temperature for 10 minutes, the measurement should be executed. Measurement should be executed in a stable, windless, and dark room. Optical specifications are measured by Topcon BM-7orBM-5 luminance meter 1.0° field of view at a distance of 50cm and normal direction.

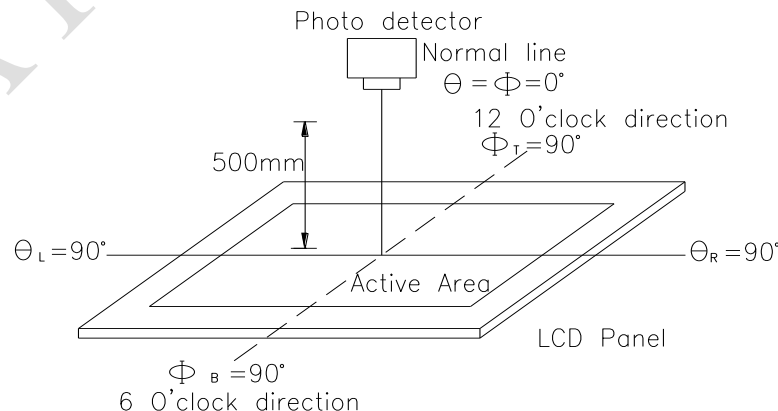
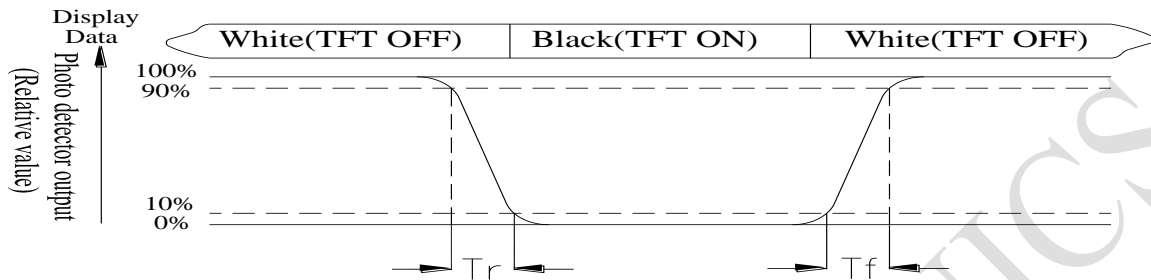

Fig. 11.2. Optical measurement system setup

Note 3: Definition of Response time:

The response time is defined as the LCD optical switching time interval between “White” state and “Black” state. Rise time,  $T_r$ , is the time between photo detector output intensity changed from 90% to 10%. And fall time,  $T_f$ , is the time between photo detector output intensity changed from 10% to 90%



Note 4: Definition of contrast ratio:

The contrast ratio is defined as the following expression.

$$\text{Contrast ratio (CR)} = \frac{\text{Luminance measured when LCD on the "White" state}}{\text{Luminance measured when LCD on the "Black" state}}$$

Note 5: White  $V_i = V_{i50} \pm 1.5V$

Black  $V_i = V_{i50} \pm 2.0V$

“±” means that the analog input signal swings in phase with VCOM signal.

“±” means that the analog input signal swings out of phase with VCOM signal.

The 100% transmission is defined as the transmission of LCD panel when all the input terminals of module are electrically opened.

Note 6: Measured at the center area of the panel when all the input terminals of LCD panel are electrically opened.

## 12. Reliability

Content of Reliability Test (Wide temperature, -20°C~70°C)

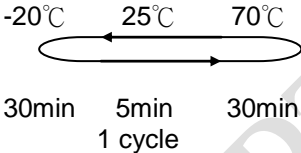
Environmental Test			
Test Item	Content of Test	Test Condition	Note
High Temperature storage	Endurance test applying the high storage temperature for a long time.	80°C 200hrs	2
Low Temperature storage	Endurance test applying the low storage temperature for a long time.	-30°C 200hrs	1,2
High Temperature Operation	Endurance test applying the electric stress (Voltage & Current) and the thermal stress to the element for a long time.	70°C 200hrs	—
Low Temperature Operation	Endurance test applying the electric stress under low temperature for a long time.	-20°C 200hrs	1
High Temperature/ Humidity Operation	The module should be allowed to stand at 60°C,90%RH max	60°C,90%RH 96hrs	1,2
Thermal shock resistance	The sample should be allowed stand the following 10 cycles of operation  <div style="text-align: center;">  <p>-20°C      25°C      70°C</p> <p>30min    5min    30min</p> <p>1 cycle</p> </div>	-20°C/70°C 10 cycles	—
Vibration test	Endurance test applying the vibration during transportation and using.	Total fixed amplitude : 3 15mm Vibration Frequency : 10~55Hz One cycle 60 seconds to 3 directions of X,Y,Z for Each 15 minutes	3
Static electricity test	Endurance test applying the electric stress to the terminal.	VS=±600V(contact) ,±800v(air), RS=330Ω CS=150pF 10 times	—

Note1: No dew condensation to be observed.

Note2: The function test shall be conducted after 4 hours storage at the normal Temperature and humidity after remove from the test chamber.

Note3: The packing have to including into the vibration testing.

### 13.PACKAGE SPECIFICATION

<b>LCM Model</b>	RFP620A-6XW-DNN	<b>LCM 包裝規格書</b> <b>LCM Packaging Specifications</b>	<b>Approve</b>	<b>Check</b>	<b>Contact</b>
<b>Drawing NO.</b>			<b>DATE</b>	初版	版次 Ver
			14'04/16	13'11/14	A

**1.包裝材料規格表 (Packaging Material) :(per carton)**

NO.	Item	Model	Dimensions	Quantity
1	成品 (LCM)	RFP620A-6XW-DNN		60
2	TRAY 盤 (2)	PKCA1XXXXXXXXXXXX0280	315*265mm	30
3	BP01 內盒(3)Product Box	PK3R1XXXXXXXXXXXX0001	332*280*100mm	6
4	泡棉(4)Foam	----	283*230*8mm	6
5	外紙箱(5)Carton	PK4Q1XXXXXXXXXXXX0000	565*340*320mm	1
6				
7				
8				
9				

**2.單箱數量規格表(Packaging Specifications and Quantity) :**

(1)LCM quantity per box : no per tray      2    x no of tray    5      =10

(2)Total LCM quantity in carton : quantity per box    10    x no of boxes    6      =60

**特 記 事 項 (REMARK)**

<p>1. Label Specifications :</p> <table border="1" style="width:100%; height: 40px;"> <tr> <td>MOEEL:</td> </tr> <tr> <td>LOT NO :</td> </tr> <tr> <td>QUANTITY:</td> </tr> <tr> <td>CHECK:</td> </tr> </table>	MOEEL:	LOT NO :	QUANTITY:	CHECK:	
MOEEL:					
LOT NO :					
QUANTITY:					
CHECK:					

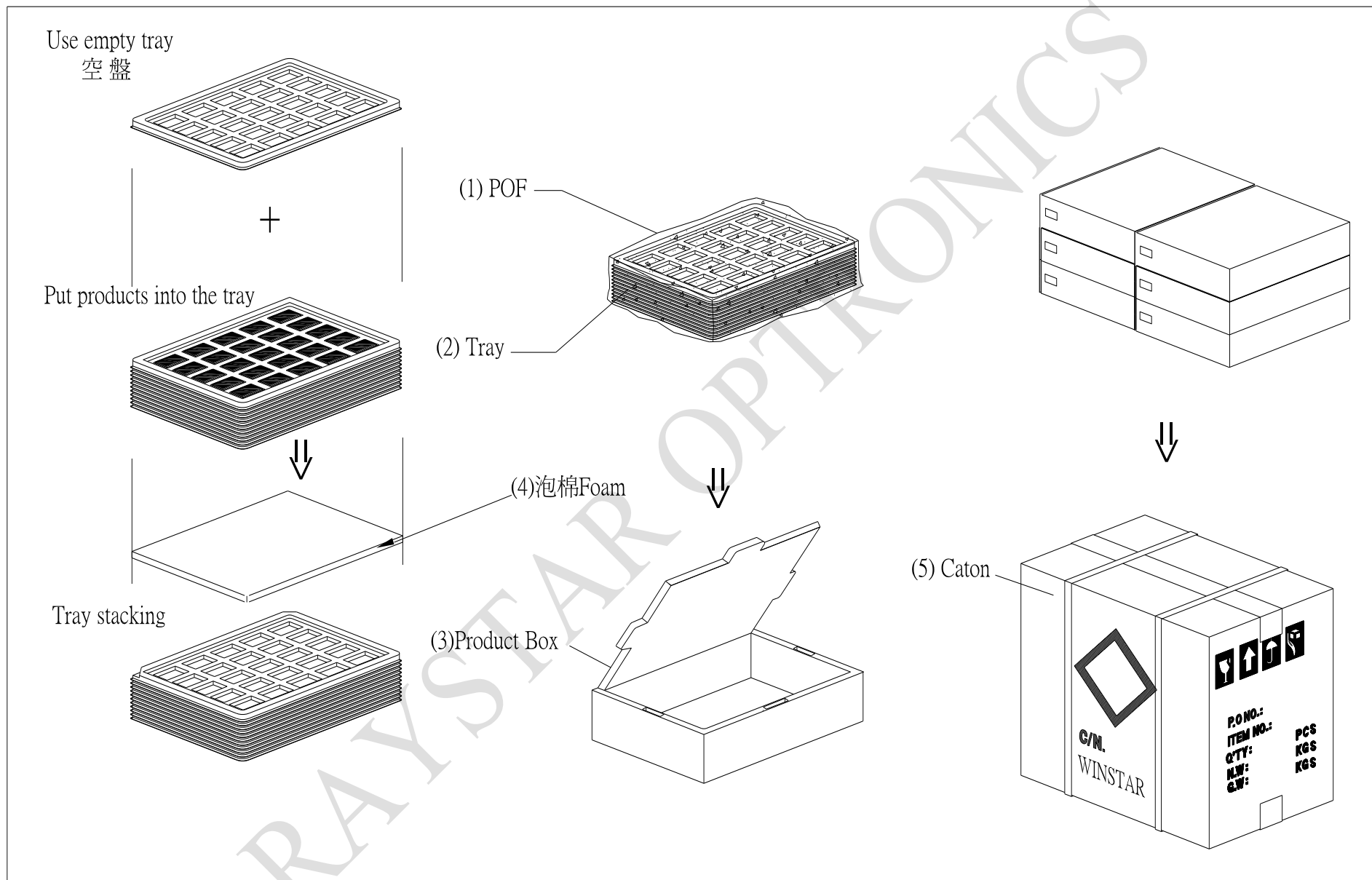

## 14.Initial Code For Reference

```
void Initial_code()
{
    Write_Command(0xae);
    Write_Data(0xa5);

    Write_Command(0x61);
    Write_Data(0x0f);
    Write_Data(0x04);
    Write_Data(0x02); // or 0Xa5 (older version command)
    Write_Data(0xa5);

    Write_Command(0x62);
    Write_Data(0x00);
    Write_Data(0x3b);
    Write_Data(0x1b);
    Write_Data(0xa5);

    Write_Command(0x63);
    Write_Data(0x05);
    Write_Data(0x0f);
    Write_Data(0xa5);
    Write_Data(0xa5);

    Write_Command(0x24);
    Write_Data(0x01);
    Write_Data(0xa5);
    Write_Data(0xa5);
    Write_Data(0xa5);

    Write_Command(0x22);
    Write_Data(0x02);
    Write_Data(0xa5);
    Write_Data(0xa5);
    Write_Data(0xa5);

    Write_Command(0x91);
    Write_Data(0x00);
    Write_Data(0x21);
    Write_Data(0x23);
    Write_Data(0x24);

    Write_Command(0x92);
    Write_Data(0x27);
    Write_Data(0x28);
    Write_Data(0x29);
    Write_Data(0x2a);
}
```

```
Write_Command(0x93);  
Write_Data(0x2b);  
Write_Data(0x2c);  
Write_Data(0x2d);  
Write_Data(0x2e);
```

```
Write_Command(0x94);  
Write_Data(0x30);  
Write_Data(0x31);  
Write_Data(0x32);  
Write_Data(0x3f);
```

```
Write_Command(0x99);  
Write_Data(0x00);  
Write_Data(0x21);  
Write_Data(0x23);  
Write_Data(0x26);
```

```
Write_Command(0x9a);  
Write_Data(0x27);  
Write_Data(0x28);  
Write_Data(0x29);  
Write_Data(0x2a);
```

```
Write_Command(0x9b);  
Write_Data(0x2b);  
Write_Data(0x2c);  
Write_Data(0x2d);  
Write_Data(0x2e);
```

```
Write_Command(0x9c);  
Write_Data(0x30);  
Write_Data(0x35);  
Write_Data(0x3b);  
Write_Data(0x3f);
```

```
Write_Command(0x12);  
Write_Data(0xa5);
```

```
Write_Command(0x15);  
Write_Data(0xa5);
```

```
}
```

**LCM Sample Estimate Feedback Sheet**
**Module Number :** \_\_\_\_\_

**1 、 Panel Specification :**

1. Panel Type :	<input type="checkbox"/> Pass	<input type="checkbox"/> NG , _____
2. View Direction :	<input type="checkbox"/> Pass	<input type="checkbox"/> NG , _____
3. Numbers of Dots :	<input type="checkbox"/> Pass	<input type="checkbox"/> NG , _____
4. View Area :	<input type="checkbox"/> Pass	<input type="checkbox"/> NG , _____
5. Active Area :	<input type="checkbox"/> Pass	<input type="checkbox"/> NG , _____
6. Operating Temperature :	<input type="checkbox"/> Pass	<input type="checkbox"/> NG , _____
7. Storage Temperature :	<input type="checkbox"/> Pass	<input type="checkbox"/> NG , _____
8. Others :	_____	

**2 、 Mechanical Specification :**

1. PCB Size :	<input type="checkbox"/> Pass	<input type="checkbox"/> NG , _____
2. Frame Size :	<input type="checkbox"/> Pass	<input type="checkbox"/> NG , _____
3. Material of Frame :	<input type="checkbox"/> Pass	<input type="checkbox"/> NG , _____
4. Connector Position :	<input type="checkbox"/> Pass	<input type="checkbox"/> NG , _____
5. Fix Hole Position :	<input type="checkbox"/> Pass	<input type="checkbox"/> NG , _____
6. Backlight Position :	<input type="checkbox"/> Pass	<input type="checkbox"/> NG , _____
7. Thickness of PCB :	<input type="checkbox"/> Pass	<input type="checkbox"/> NG , _____
8. Height of Frame to PCB :	<input type="checkbox"/> Pass	<input type="checkbox"/> NG , _____
9. Height of Module :	<input type="checkbox"/> Pass	<input type="checkbox"/> NG , _____
10. Others :	<input type="checkbox"/> Pass	<input type="checkbox"/> NG , _____

**3 、 Relative Hole Size :**

1. Pitch of Connector :	<input type="checkbox"/> Pass	<input type="checkbox"/> NG , _____
2. Hole size of Connector :	<input type="checkbox"/> Pass	<input type="checkbox"/> NG , _____
3. Mounting Hole size :	<input type="checkbox"/> Pass	<input type="checkbox"/> NG , _____
4. Mounting Hole Type :	<input type="checkbox"/> Pass	<input type="checkbox"/> NG , _____
5. Others :	<input type="checkbox"/> Pass	<input type="checkbox"/> NG , _____

**4 、 Backlight Specification :**

1. B/L Type :	<input type="checkbox"/> Pass	<input type="checkbox"/> NG , _____
2. B/L Color :	<input type="checkbox"/> Pass	<input type="checkbox"/> NG , _____
3. B/L Driving Voltage (Reference for LED Type) :	<input type="checkbox"/> Pass	<input type="checkbox"/> NG , _____
4. B/L Driving Current :	<input type="checkbox"/> Pass	<input type="checkbox"/> NG , _____
5. Brightness of B/L :	<input type="checkbox"/> Pass	<input type="checkbox"/> NG , _____
6. B/L Solder Method :	<input type="checkbox"/> Pass	<input type="checkbox"/> NG , _____
7. Others :	<input type="checkbox"/> Pass	<input type="checkbox"/> NG , _____

 >> **Go to page 2** <<



<b>Module Number :</b> _____		
<b>5 · Electronic Characteristics of Module :</b>		
1.Input Voltage :	<input type="checkbox"/> Pass	<input type="checkbox"/> NG , _____
2.Supply Current :	<input type="checkbox"/> Pass	<input type="checkbox"/> NG , _____
3.Driving Voltage for LCD :	<input type="checkbox"/> Pass	<input type="checkbox"/> NG , _____
4.Contrast for LCD :	<input type="checkbox"/> Pass	<input type="checkbox"/> NG , _____
5.B/L Driving Method :	<input type="checkbox"/> Pass	<input type="checkbox"/> NG , _____
6.Negative Voltage Output :	<input type="checkbox"/> Pass	<input type="checkbox"/> NG , _____
7.Interface Function :	<input type="checkbox"/> Pass	<input type="checkbox"/> NG , _____
8.LCD Uniformity :	<input type="checkbox"/> Pass	<input type="checkbox"/> NG , _____
9.ESD test :	<input type="checkbox"/> Pass	<input type="checkbox"/> NG , _____
10.Others :	<input type="checkbox"/> Pass	<input type="checkbox"/> NG , _____
<b>6 · Summary :</b>		
<p style="text-align: right; margin-right: 50px;">Sales signature : _____</p> <p style="text-align: right; margin-right: 100px;">Customer Signature : _____</p> <p style="text-align: right; margin-right: 100px;">Date :    /    /</p>		

**LCM Sample Estimate Feedback Sheet**

**Module Number :** \_\_\_\_\_

**1 、 Panel Specification :**

1. Panel Type :	<input type="checkbox"/> Pass	<input type="checkbox"/> NG , _____
2. View Direction :	<input type="checkbox"/> Pass	<input type="checkbox"/> NG , _____
3. Numbers of Dots :	<input type="checkbox"/> Pass	<input type="checkbox"/> NG , _____
4. View Area :	<input type="checkbox"/> Pass	<input type="checkbox"/> NG , _____
5. Active Area :	<input type="checkbox"/> Pass	<input type="checkbox"/> NG , _____
6. Operating Temperature :	<input type="checkbox"/> Pass	<input type="checkbox"/> NG , _____
7. Storage Temperature :	<input type="checkbox"/> Pass	<input type="checkbox"/> NG , _____
8. Others :	_____	

**2 、 Mechanical Specification :**

1. PCB Size :	<input type="checkbox"/> Pass	<input type="checkbox"/> NG , _____
2. Frame Size :	<input type="checkbox"/> Pass	<input type="checkbox"/> NG , _____
3. Material of Frame :	<input type="checkbox"/> Pass	<input type="checkbox"/> NG , _____
4. Connector Position :	<input type="checkbox"/> Pass	<input type="checkbox"/> NG , _____
5. Fix Hole Position :	<input type="checkbox"/> Pass	<input type="checkbox"/> NG , _____
6. Backlight Position :	<input type="checkbox"/> Pass	<input type="checkbox"/> NG , _____
7. Thickness of PCB :	<input type="checkbox"/> Pass	<input type="checkbox"/> NG , _____
8. Height of Frame to PCB :	<input type="checkbox"/> Pass	<input type="checkbox"/> NG , _____
9. Height of Module :	<input type="checkbox"/> Pass	<input type="checkbox"/> NG , _____
10. Others :	<input type="checkbox"/> Pass	<input type="checkbox"/> NG , _____

**3 、 Relative Hole Size :**

1. Pitch of Connector :	<input type="checkbox"/> Pass	<input type="checkbox"/> NG , _____
2. Hole size of Connector :	<input type="checkbox"/> Pass	<input type="checkbox"/> NG , _____
3. Mounting Hole size :	<input type="checkbox"/> Pass	<input type="checkbox"/> NG , _____
4. Mounting Hole Type :	<input type="checkbox"/> Pass	<input type="checkbox"/> NG , _____
5. Others :	<input type="checkbox"/> Pass	<input type="checkbox"/> NG , _____

**4 、 Backlight Specification :**

1. B/L Type :	<input type="checkbox"/> Pass	<input type="checkbox"/> NG , _____
2. B/L Color :	<input type="checkbox"/> Pass	<input type="checkbox"/> NG , _____
3. B/L Driving Voltage (Reference for LED Type) :	<input type="checkbox"/> Pass	<input type="checkbox"/> NG , _____
4. B/L Driving Current :	<input type="checkbox"/> Pass	<input type="checkbox"/> NG , _____
5. Brightness of B/L :	<input type="checkbox"/> Pass	<input type="checkbox"/> NG , _____
6. B/L Solder Method :	<input type="checkbox"/> Pass	<input type="checkbox"/> NG , _____
7. Others :	<input type="checkbox"/> Pass	<input type="checkbox"/> NG , _____

>> **Go to page 2** <<

<b>Module Number :</b> _____		
<b>5 · <u>Electronic Characteristics of Module</u> :</b>		
1.Input Voltage :	<input type="checkbox"/> Pass	<input type="checkbox"/> NG , _____
2.Supply Current :	<input type="checkbox"/> Pass	<input type="checkbox"/> NG , _____
3.Driving Voltage for LCD :	<input type="checkbox"/> Pass	<input type="checkbox"/> NG , _____
4.Contrast for LCD :	<input type="checkbox"/> Pass	<input type="checkbox"/> NG , _____
5.B/L Driving Method :	<input type="checkbox"/> Pass	<input type="checkbox"/> NG , _____
6.Negative Voltage Output :	<input type="checkbox"/> Pass	<input type="checkbox"/> NG , _____
7.Interface Function :	<input type="checkbox"/> Pass	<input type="checkbox"/> NG , _____
8.LCD Uniformity :	<input type="checkbox"/> Pass	<input type="checkbox"/> NG , _____
9.ESD test :	<input type="checkbox"/> Pass	<input type="checkbox"/> NG , _____
10.Others :	<input type="checkbox"/> Pass	<input type="checkbox"/> NG , _____
<b>6 · <u>Summary</u> :</b>		
<p style="text-align: right; margin-right: 100px;">Sales signature : _____</p> <p style="text-align: right; margin-right: 100px;">Customer Signature : _____      <u>Date</u> :   /   / _____</p>		