

Dept	Qty
DC	1
ED	1
IE	1
ISO	1
PD	1
R&D	1
SD	1
QA	1
QC	1
QF	1

REV.	DESCRIPTION	DRAWN	CHECKED	APPROVED
A	NEW RELEASE	YCH 04/27/10'		LJC 04/27/10'
B	DRAWING UPDATE	JLZ 05/10/19'		

The information provided herein is from CONNELY Electronic Co., Ltd. and is confidential. Any disclosure to a party other than the recipient is prohibited. The intellectual properties and its rights contained herein, including but not limited to, trademarks, patents, copyrights, trade secrets, and technical know-how, are owned exclusively by CONNELY or its affiliates. Unauthorized use of the information herein is strictly prohibited. CONNELY may enforce its intellectual property rights at its own discretion, failures or delays to exercise such rights does not constitute a waiver of such rights.

Warning:
During the soldering process,
The switch must be turned off.

- Notes:
- Specifications:
- Contact Resistance: 100mΩ Max.
 - Insulation Resistance: 1000MΩ Min.
 - Dielectric Withstanding Voltage: 500V AC(rms) For 1 Minute.
 - Current Rating: 25mA.
 - Voltage Rating: 24V DC rms.
 - Temperature: -25°C~+70°C.
 - Operating Life: 2000 cycle min.
- Materials:
- Contact Material: Copper Alloy.
 - Contact Plating: Gold Plating Over Nickel.
 - Insulator Material: High temperature 260°C, UL 94V-0.

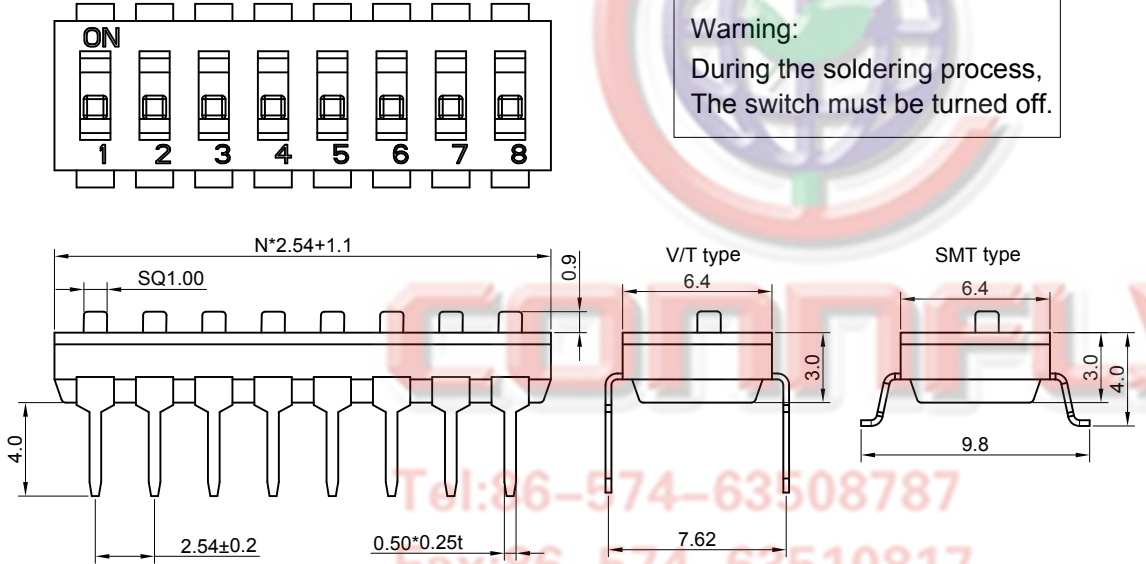

Product Number Code:
DS1040-01 - X X X X X

- X: Packing type
B: Tube
T: Tray
R: Tape & reel
- X: Acuator color
W: White
- X: Housing color
B: Black
- X: Mounting type
V: V/T type
S: SMT type
- X: No. of contacts
2 3 4 5 6 7
8 9 10 11 12

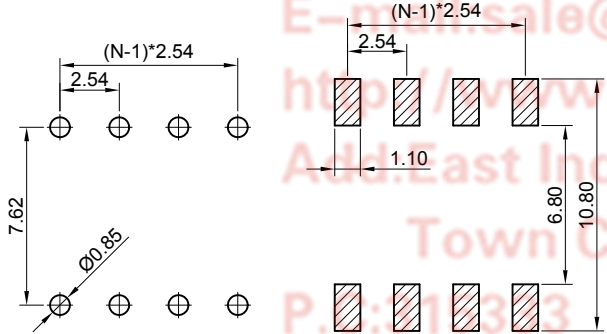

GENERAL TOLERANCE		ANGLE TOLERANCE		PROJECTION		TITLE	SWITCH PITCH 2.54mm SMT&V/T TYPE	
X.	±0.60	X.	±5°	UNITS	mm			
.X	±0.38	.X	±3°	SHEET SIZE	A4	SERIES	DS1040-01 SERIES	
.XX	±0.25	.XX	±2°	晨翔电子有限公司 CONNELY ELECTRONIC CO., LTD				
DRAWING TYPE		CUSTOMER						
SCALE	1:1	SHEET	1 OF 1					
DRAWING NO.		C-DS1040-01-XXXXX-B						