

OLED DISPLAY SPECIFICATION



RAYSTAR

RAYSTAR Optronics, Inc.
曜凌光電股份有限公司



曜凌光電股份有限公司
Raystar Optronics, Inc.

T: +886-4-2565-0761 | F: +886-4-2565-0760
sales@raystar-optronics.com | www.raystar-optronics.com

SPECIFICATION

Model No:
REX012864Z (Knob)

General Specification

The Features is described as follow:

- Module dimension: $\varnothing 39.4 \times 24.8$ mm
- Active area: 21.74×10.86 mm
- Dot Matrix: 128×64
- Dot size: 0.148×0.148 mm
- Dot pitch: 0.17×0.17 mm
- Display Mode: Passive Matrix
- Duty: 1/64 Duty
- Display Color: OLED , Monochrome
- Controller IC: SSD1306
- Interface: 4-wire SPI,I2C
- Size: 0.96 inch

Interface Pin Function

Pin No.	Symbol	Description						
1	VSS	Ground pin.						
2	VCC	Power supply for panel driving voltage. This is also the most positive power voltage supply pin.						
3	VCOMH	COM signal deselected voltage level. A capacitor should be connected between this pin and VSS.						
4	VCI	Power supply pin for core logic operation						
5	NC	No connection						
6	BS1	<p>MCU bus interface selection pins. Select appropriate logic setting as described in the following table.</p> <table border="1"> <tr> <td></td> <td>BS1</td> </tr> <tr> <td>I2C</td> <td>1</td> </tr> <tr> <td>4-wire Serial</td> <td>0</td> </tr> </table> <p>Note (1) 0 is connected to VSS (2) 1 is connected to VCI</p>		BS1	I2C	1	4-wire Serial	0
	BS1							
I2C	1							
4-wire Serial	0							
7	IREF	This is segment output current reference pin. When external IREF is used, a resistor should be connected between this pin and VSS to maintain the IREF current at a maximum of 30uA.						
8	CS#	This pin is the chip select input. (active LOW).						
9	RES#	This pin is reset signal input. When the pin is pulled LOW, initialization of the chip is executed. Keep this pin HIGH during normal operation.						
10	D/C#	When 4-wire serial interface is selected, this pin is Data/Command control pin connecting to the MCU. In I2C mode, this pin acts as SA0 for slave address selection.						
11	D0	These pins are bi-directional data bus connecting to the MCU data bus.						
12	D1	When serial interface mode is selected, D0 will be the serial clock input: SCLK; D1 will be the serial data input: SDIN and D2 should be kept NC.						
13	D2	When I2C mode is selected, D2, D1 should be tied together and serve as SDAout, SDAin in application and D0 is the serial clock input, SCL.						
14	NC	No connection						
15	NC	No connection						

16	NC	No connection
17	VCC	Power supply for panel driving voltage. This is also the most positive power voltage supply pin.
18	VSS	Ground pin.

Encoder PIN Definition

No.	Symbol	Function
A	FSW_A	Encoder terminal signal-A
B	FSW_B	Encoder terminal signal-B
C	FSW_C	Encoder terminal signal-C
D	FSW_D	Ground

RAYSTAR OPTRONICS

Contour Drawing & Block Diagram

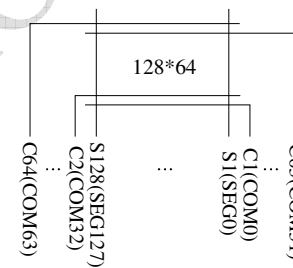
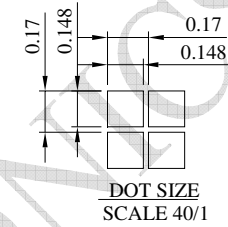
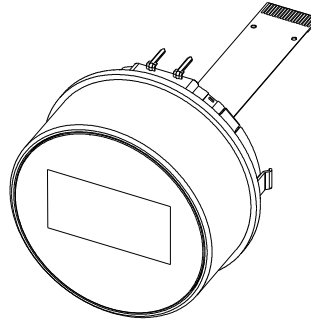
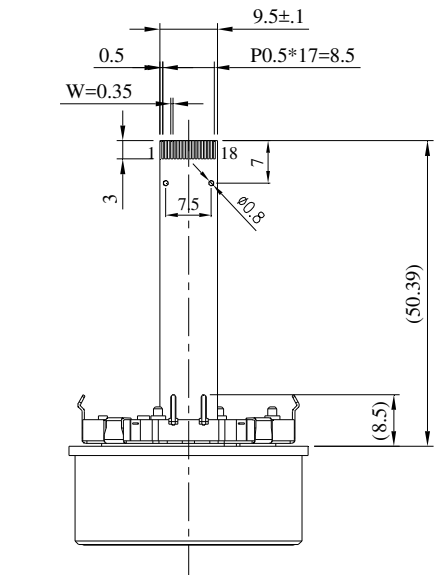

PIN	SYMBOL
1	VSS
2	VCC
3	VCOMH
4	VCI
5	NC
6	BS1
7	IREF
8	CS#
9	RES#
10	D/C#
11	D0
12	D1
13	D2
14	NC
15	NC
16	NC
17	VCC
18	VSS

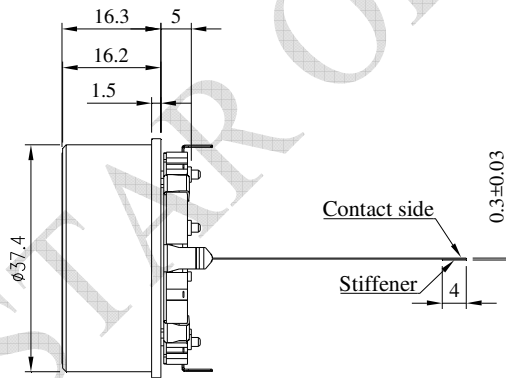
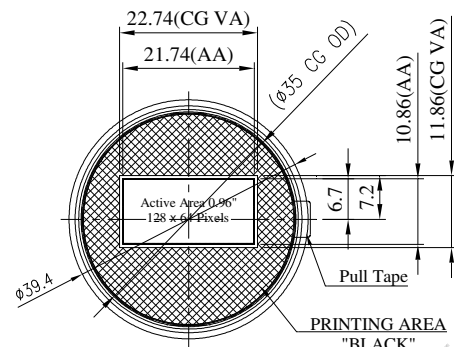

ENCODER
(ALPS EC35AH240403)

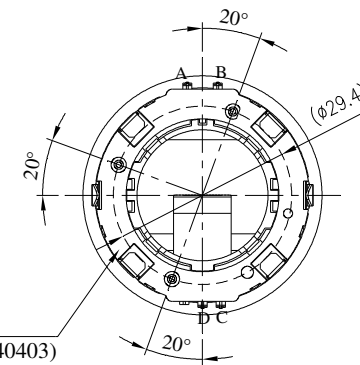

ENCODER	
PIN	SYMBOL
A	FSW_A
B	FSW_B
C	FSW_C
D	FSW_D

The non-specified tolerance of dimension is ± 0.3 mm .

Absolute Maximum Ratings

Item	Symbol	Min	Max	Unit
Supply Voltage	VCI	-0.3	4.0	V
Supply Voltage for Display	VCC	0	15	V
Operating Temperature	TOP	-20	+70	°C
Storage Temperature	TST	-30	+80	°C

Electrical Characteristics

DC Electrical Characteristics

Item	Symbol	Condition	Min	Typ	Max	Unit
Supply Voltage	VCI	—	1.65	3.0	3.3	V
Supply Voltage for Display	VCC	—	6	12	12.5	V
Input High Volt.	VIH	—	0.8xVCI	—	—	V
Input Low Volt.	VIL	—	—	—	0.2xVCI	V
Output High Volt.	VOH	I _{out} = 100uA	0.9xVCI	—	—	V
Output Low Volt.	VOL	I _{out} = 100uA	—	—	0.1xVCI	V
Operating Current for VCC (VCC Supplied Externally)	ICC	VCC = 12V	—	6	12	mA