



## UF5305

Preliminary

POWER MOSFET

### -31A, -55V P-CHANNEL POWER MOSFET

#### DESCRIPTION

The UTC **UF5305** is a P-channel Power MOSFET, it uses UTC's advanced technology to provide the customers with high switching speed and a minimum on-state resistance.

The UTC **UF5305** is suitable for all commercial-industrial applications, etc.

#### FEATURES

- \*  $R_{DS(ON)} \leq 0.06 \Omega @ V_{GS} = -10V, I_D = -16A$
- \* High Switching Speed
- \* Dynamic  $dv/dt$  Rating

#### SYMBOL

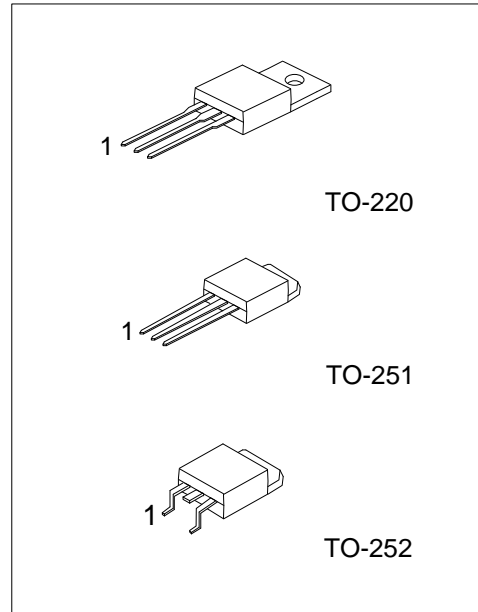
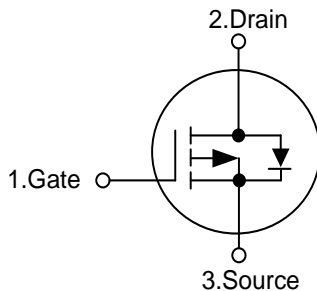

#### ORDERING INFORMATION

Ordering Number		Package	Pin Assignment			Packing
Lead Free	Halogen Free		1	2	3	
UF5305L-TA3-T	UF5305G-TA3-T	TO-220	G	D	S	Tube
UF5305L-TM3-T	UF5305G-TM3-T	TO-251	G	D	S	Tube
UF5305L-TN3-T	UF5305G-TN3-T	TO-252	G	D	S	Tube
UF5305L-TN3-R	UF5305G-TN3-R	TO-252	G	D	S	Tape Reel

Note: Pin Assignment: G: Gate D: Drain S: Source

<p>UF5305G-TA3-T</p> <p>(1) Packing Type</p> <p>(2) Package Type</p> <p>(3) Green Package</p>	<p>(1) T: Tube, R: Tape Reel</p> <p>(2) TA3: TO-220, TM3: TO-251, TN3: TO-252</p> <p>(3) G: Halogen Free and Lead Free, L: Lead Free</p>
---	--

#### MARKING

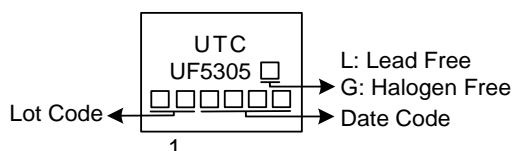

### ■ ABSOLUTE MAXIMUM RATING

PARAMETER		SYMBOL	RATINGS	UNIT	
Drain-Source Voltage		$V_{DSS}$	-55	V	
Gate-Source Voltage		$V_{GSS}$	$\pm 20$	V	
Drain Current	Continuous	$I_D$	$V_{GS}=-10V, T_C=25^\circ C$	-31	A
			$V_{GS}=-10V, T_C=100^\circ C$	-22	A
	Pulsed (Note 2)		$I_{DM}$	-110	A
Avalanche Current (Note 2)		$I_{AR}$	-16	A	
Avalanche Energy	Single Pulse (Note 3)		$E_{AS}$	280	mJ
	Repetitive (Note 2)		$E_{AR}$	11	mJ
Peak Diode Recovery dv/dt (Note 4)		dv/dt	-5.0	V/ns	
Power Dissipation ( $T_C=25^\circ C$ )	TO-220	$P_D$	110	W	
	TO-251		42	W	
	TO-252				
Junction Temperature		$T_J$	-55 ~ +150	$^\circ C$	
Storage Temperature Range		$T_{STG}$	-55 ~ +150	$^\circ C$	

Notes: 1. Absolute maximum ratings are those values beyond which the device could be permanently damaged.

Absolute maximum ratings are stress ratings only and functional device operation is not implied.

2. Repetitive Rating: Pulse width limited by maximum junction temperature.

3.  $V_{DD}=-25V$ , Starting  $T_J=25^\circ C$ ,  $L=2.1mH$ ,  $R_G=25\Omega$ ,  $I_{AS}=-16A$

4.  $I_{SD}\leq -16A$ ,  $di/dt\leq -280A/\mu s$ ,  $V_{DD}\leq BV_{DSS}$ ,  $T_J\leq 150^\circ C$

### ■ THERMAL DATA

PARAMETER		SYMBOL	RATINGS	UNIT
Junction to Ambient	TO-220	$\theta_{JA}$	62	$^\circ C/W$
	TO-251		90	$^\circ C/W$
	TO-252			
Junction to Case	TO-220	$\theta_{JC}$	1.1	$^\circ C/W$
	TO-251		2.97 (Note)	$^\circ C/W$
	TO-252			

Note: Device mounted on FR-4 substrate  $P_c$  board, 2oz copper, with 1inch square copper plate.

### ■ ELECTRICAL CHARACTERISTICS (T<sub>J</sub>=25°C, unless otherwise specified)

PARAMETER	SYMBOL	TEST CONDITIONS	MIN	TYP	MAX	UNIT
<b>OFF CHARACTERISTICS</b>						
Drain-Source Breakdown Voltage	BV <sub>DSS</sub>	V <sub>GS</sub> =0V, I <sub>D</sub> =-250μA	-55			V
Breakdown Voltage Temperature Coefficient	ΔBV <sub>DSS</sub> /ΔT <sub>J</sub>	Reference to 25°C, I <sub>D</sub> =-1mA		-0.034		V/°C
Drain-Source Leakage Current	I <sub>DSS</sub>	V <sub>DS</sub> =-55V, V <sub>GS</sub> =0V			-25	μA
		V <sub>DS</sub> =-44V, V <sub>GS</sub> =0V, T <sub>J</sub> =150°C			-250	μA
Gate-Source Leakage Current	Forward	I <sub>GSS</sub>				nA
	Reverse					
		V <sub>GS</sub> =-20V, V <sub>DS</sub> =0V			-100	nA
<b>ON CHARACTERISTICS</b>						
Static Drain-Source On-Resistance	R <sub>DS(ON)</sub>	V <sub>GS</sub> =-10V, I <sub>D</sub> =-16A (Note 2)			0.06	Ω
Gate Threshold Voltage	V <sub>GS(TH)</sub>	V <sub>DS</sub> =V <sub>GS</sub> , I <sub>D</sub> =-250μA	-2.0		-4.0	V
<b>DYNAMIC PARAMETERS</b>						
Input Capacitance	C <sub>ISS</sub>	V <sub>GS</sub> =0V, V <sub>DS</sub> =-25V, f=1.0MHz		1200		pF
Output Capacitance	C <sub>OSS</sub>			520		pF
Reverse Transfer Capacitance	C <sub>RSS</sub>			250		pF
<b>SWITCHING PARAMETERS</b>						
Total Gate Charge	Q <sub>G</sub>	I <sub>D</sub> =-16A, V <sub>DS</sub> =-44V, V <sub>GS</sub> =-10V (Note 2)			63	nC
Gate-to-Source Charge	Q <sub>GS</sub>				13	nC
Gate-to-Drain ("Miller") Charge	Q <sub>GD</sub>				29	nC
Turn-ON Delay Time	t <sub>D(ON)</sub>	V <sub>DD</sub> =-28V, I <sub>D</sub> =-16A, R <sub>G</sub> =6.8Ω R <sub>D</sub> =1.6Ω (Note 2)		14		ns
Rise Time	t <sub>R</sub>			66		ns
Turn-OFF Delay Time	t <sub>D(OFF)</sub>			39		ns
Fall Time	t <sub>F</sub>			63		ns
<b>SOURCE- DRAIN DIODE RATINGS AND CHARACTERISTICS</b>						
Maximum Body Diode Continuous Source Current	I <sub>S</sub>				-31	A
Maximum Body-Diode Pulsed Current (Note 1)	I <sub>SM</sub>				-110	A
Drain-Source Diode Forward Voltage	V <sub>SD</sub>	T <sub>J</sub> =25°C, I <sub>S</sub> =-16A, V <sub>GS</sub> =0V (Note 2)			-1.4	V
Body Diode Reverse Recovery Time	t <sub>RR</sub>	T <sub>J</sub> =25°C, I <sub>F</sub> =-16A, di/dt=-100A/μs (Note 2)		71	110	ns
Body Diode Reverse Recovery Charge	Q <sub>RR</sub>				170	250

Notes: 1. Repetitive rating; pulse width limited by max. junction temperature.

2. Pulse Test: Pulse width ≤ 300μs, Duty cycle ≤ 2%.

■ TEST CIRCUITS AND WAVEFORMS

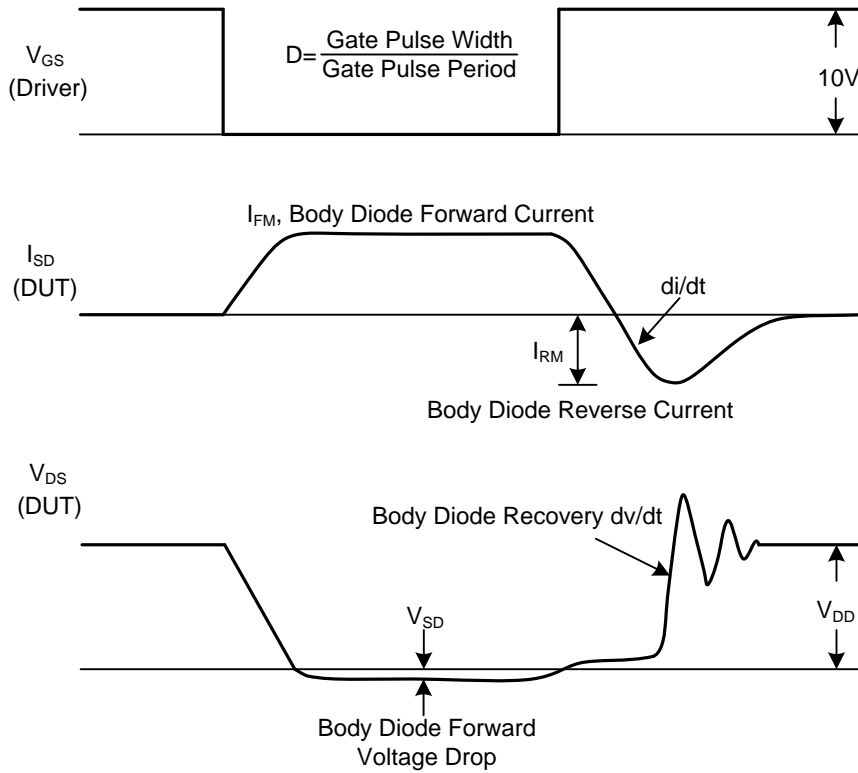
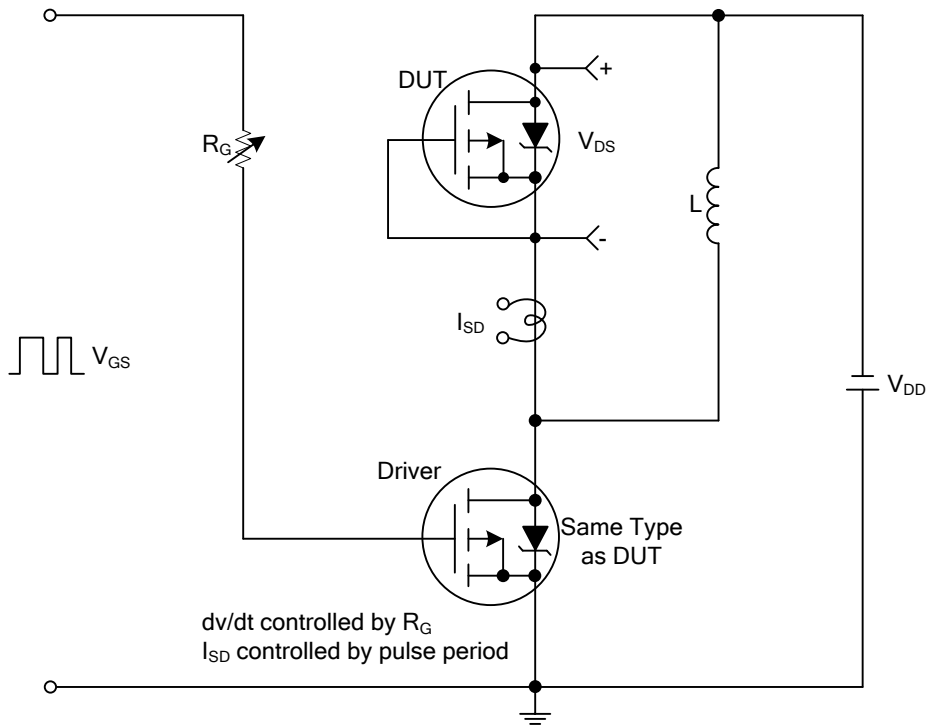

Peak Diode Recovery dv/dt Test Circuit and Waveforms

■ TEST CIRCUITS AND WAVEFORMS

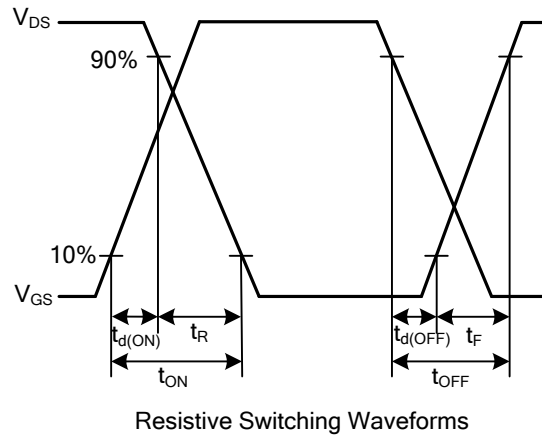
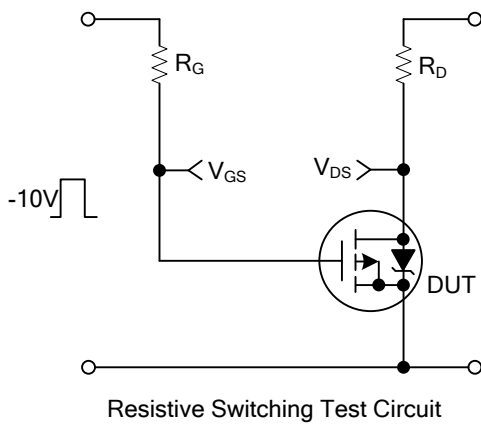
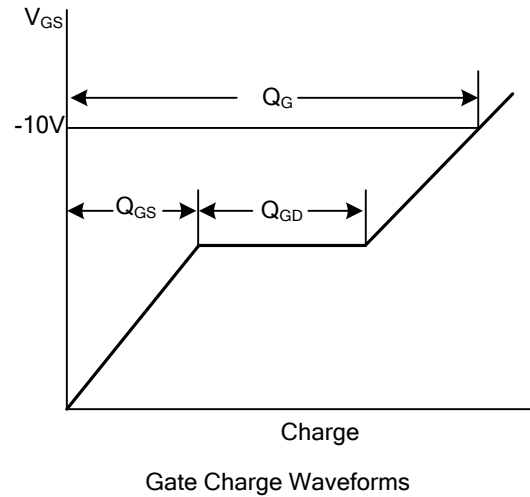
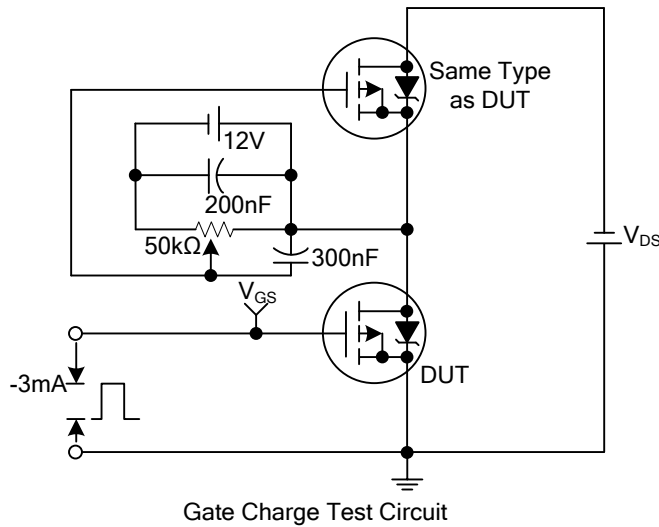

UTC assumes no responsibility for equipment failures that result from using products at values that exceed, even momentarily, rated values (such as maximum ratings, operating condition ranges, or other parameters) listed in products specifications of any and all UTC products described or contained herein. UTC products are not designed for use in life support appliances, devices or systems where malfunction of these products can be reasonably expected to result in personal injury. Reproduction in whole or in part is prohibited without the prior written consent of the copyright owner. UTC reserves the right to make changes to information published in this document, including without limitation specifications and product descriptions, at any time and without notice. This document supersedes and replaces all information supplied prior to the publication hereof.