

Digital Earth Leakage Current Detector IC

FEATURES

- Power Supply VDD 4.0V to 5.5V
- Operating Temperature -40 to 105
- Built-in High Precision ADC 14-Bit
- Sinc3 Digital Filter -3dB Frequency = 150Hz
- Internal Power Supply V_{REG}=3.3V
V_{COM}=1.65V
- Earth Leakage Detector Condition (TMD)
Type A / Type AC switchable
- Five times trip level detection
NJU9102: Immediate response
NJU9102A: No immediate response
- Control Circuit
Earth Leakage Detector Condition (TMD)
Sampling Counter (SCRT)
- Package DMP8

GENERAL DESCRIPTION

NJU9102/A is a digital detector IC for earth leakage current breaker. The built-in ADC converts from an analog signal from ZCT (Zero-phase-sequence Current Transformer) to digital data, and processes digital data based on an earth leakage current detector condition. As a result of data processing, NJU9102/A outputs a one-shot pulse on SCRT terminal when an analog signal is judged to a leakage condition, and turns on an external thyristor.

APPLICATION

- Earth Leakage Current Breaker

EQUIVALENT CIRCUIT · BLOCK DIAGRAM

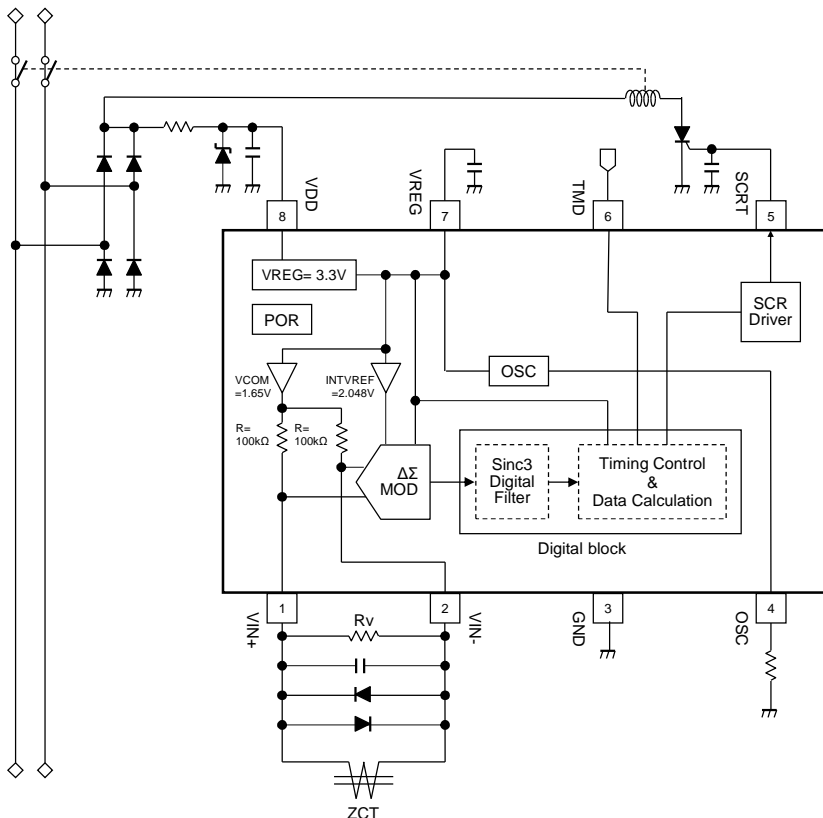

■PIN CONFIGURATION

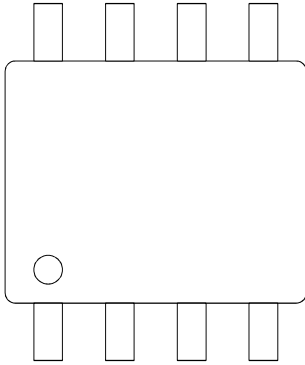

PIN NO.	SYMBOL	DESCRIPTION
1	VIN+	Voltage reference input
2	VIN-	Input from ZCT
3	GND	Ground
4	OSC	Oscillator
5	SCRT	Output of Thyristor
6	TMD	Earth leakage detector condition
7	VREG	Output of internal regulator
8	VDD	Power Supply

■MARK INFORMATION

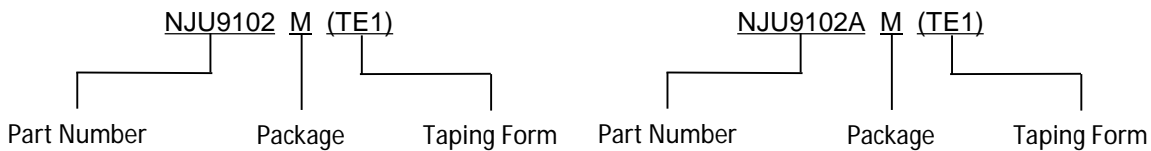

■ORDERING INFORMATION

PART NUMBER	PACKAGE OUTLINE	RoHS	HALOGEN-FREE	TERMINAL FINISH	MARKING	WEIGHT (mg)	MOQ(pcs)
NJU9102/AM	DMP8	yes	yes	Sn-2Bi	9102/9102A	95	2,000

■ABSOLUTE MAXIMUM RATINGS

PARAMETER	SYMBOL	RATINGS	UNIT
Power Supply Voltage	V_{DD}	7 (Note1)	V
Power Dissipation	P_D	425 (Note2)	mW
Maximum Input Voltage	V_{IMAX}	0 to V_{REG}	V
Operating Temperature Range	T_{opr}	-40 to 105	°C
Storage Temperature Range	T_{stg}	-40 to 150	°C

(1): Because differences between absolutely maximum power supply voltage and operating power supply are small, prevent you from exceeding the absolutely maximum power supply voltage by spikes voltage.

(2): Mounted on glass epoxy board.

(76.2×114.3×1.6mm: based on EIA/JDEC standard, 4Layers).

■ELECTRICAL CHARACTERISTICS ($T_a=25\text{ °C}$, $V_{DD}=5\text{V}$, $f_{in}=60\text{Hz}$, $R_{OSC}=120\text{ k}\Omega$)

PARAMETER	SYMBOL	TEST CONDITION	MIN.	TYP.	MAX.	UNIT
Power Supply						
Supply Voltage	V_{DD}		4.0	-	5.5	V
Current Consumption 1	I_{DD1}	During standby	-	300	380	μA
Current Consumption 2	I_{DD2}	During leakage current detection : No load	-	240	I_{DD1}	μA
Internal Power Supply						
Internal Power Supply	V_{REG}		3.0	3.3	3.6	V
Analog Input						
Input Resistance	R_{IN}		80	100	120	$\text{k}\Omega$
Input Bias Voltage	V_{COM}		1.50	1.65	1.80	V
Earth Leakage Detect						
Earth Leakage Detection AC Input Voltage	V_{TAC}	$V_{IN} = V_{IN+} - V_{IN-} $, $f_{in}=60\text{Hz}$	5.2	6.5	7.8	mVrms
SCR Operating Circuit						
SCRT terminal "H" Output Current	I_{OH}	$V_O=0.8\text{V}$	-150	-200	-	μA
SCRT terminal "L" Output Voltage	V_{OL}	$I_{OL}=200\mu\text{A}$	-	-	0.2	V
I_{OH} Hold Power Supply	V_{OHK}	$I_{OH}=-150\mu\text{A}$	4.0	-	-	V
Other						
OSC terminal Voltage	V_{OSC}	$R_{OSC}=120\text{ k}\Omega$	-	0.47	-	V
TMD terminal "H" Input Voltage	V_{IHTMD}		2.4	-	V_{REG}	V
TMD terminal "L" Input Voltage	V_{ILTMD}		0	-	0.8	V
Reset Timer Pulse Width	T_{WRET}	$R_{OSC}=120\text{ k}\Omega$	50	60	70	msec

(Note3) R_{OSC} influences all operations. It is recommended for R_{OSC} to use high precision resistance.

■ TYPICAL CHARACTERISTICS

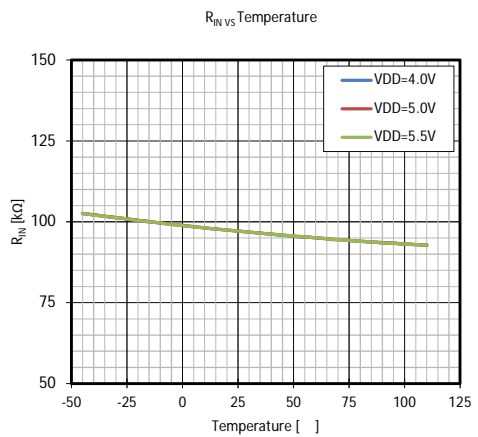
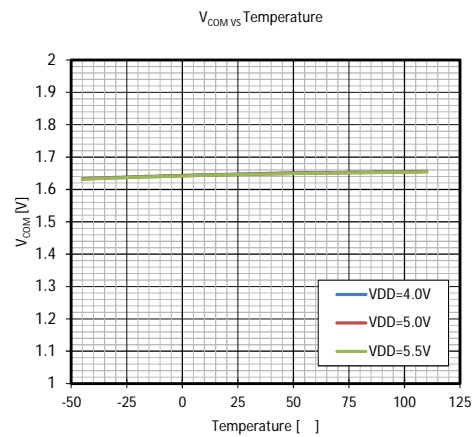
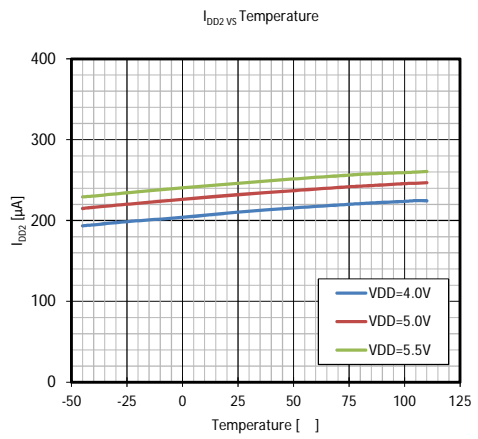
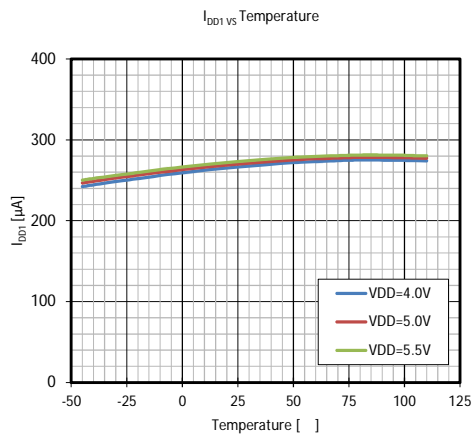
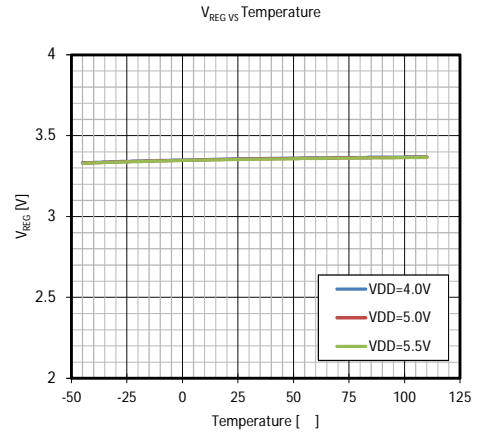
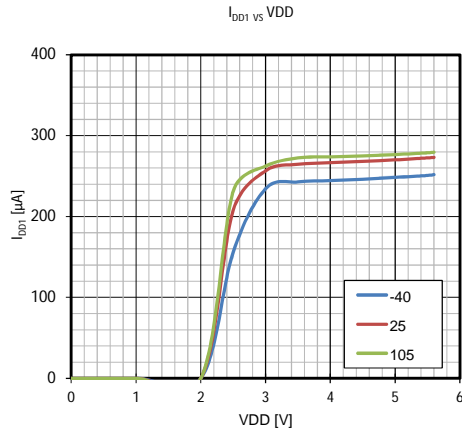

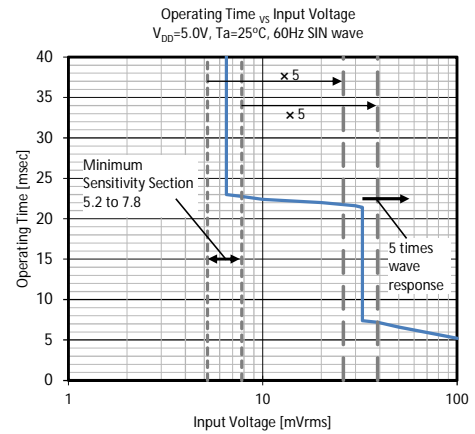
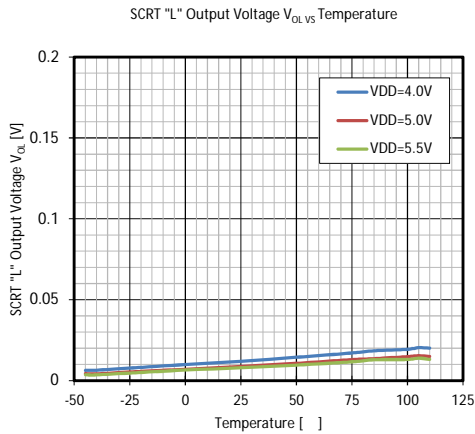
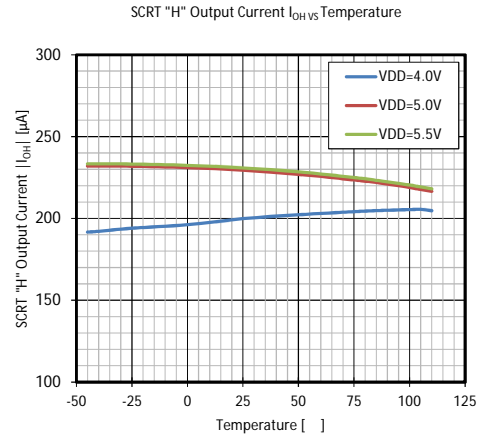
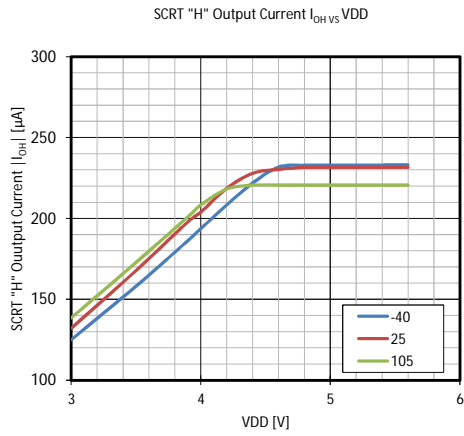
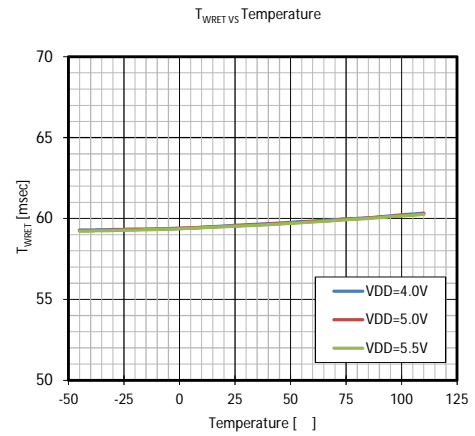
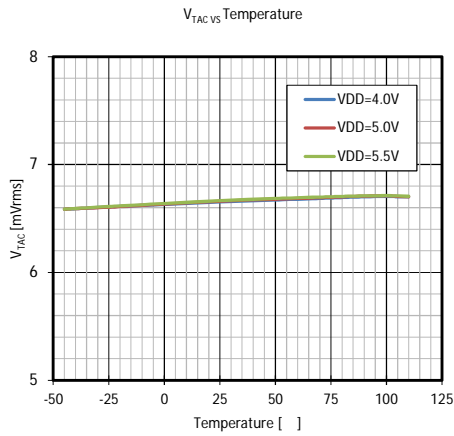

(NJU9102 only)

■ MEASUREMENT CIRCUIT ($C_{VDD}=10\mu\text{F}$, $C_{VREG}=2.2\mu\text{F}$, $R_{OSC}=120\text{ k}\Omega$)

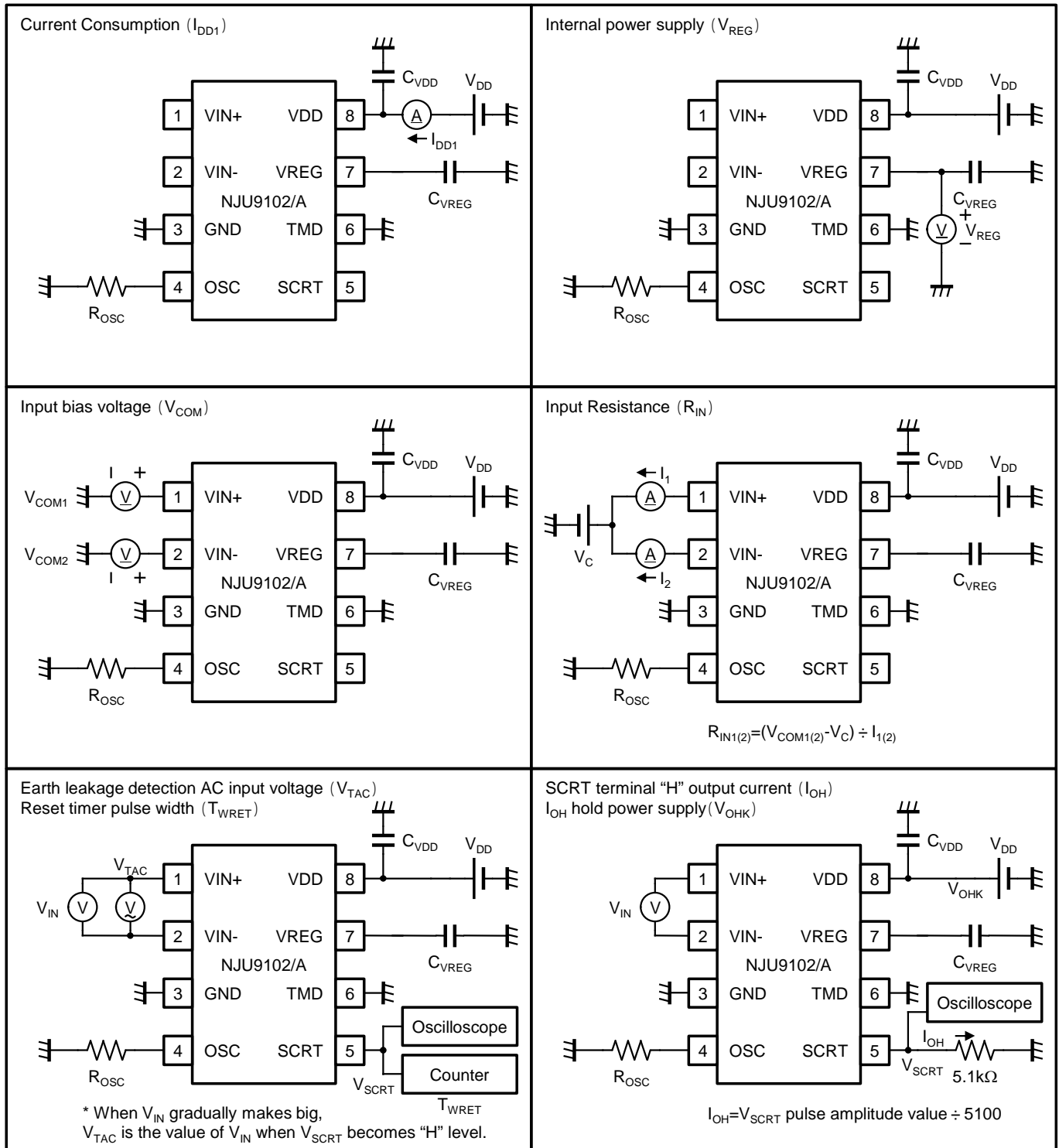

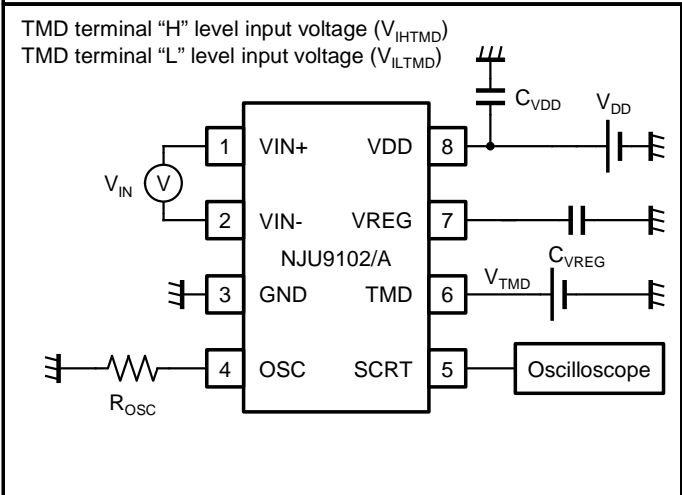
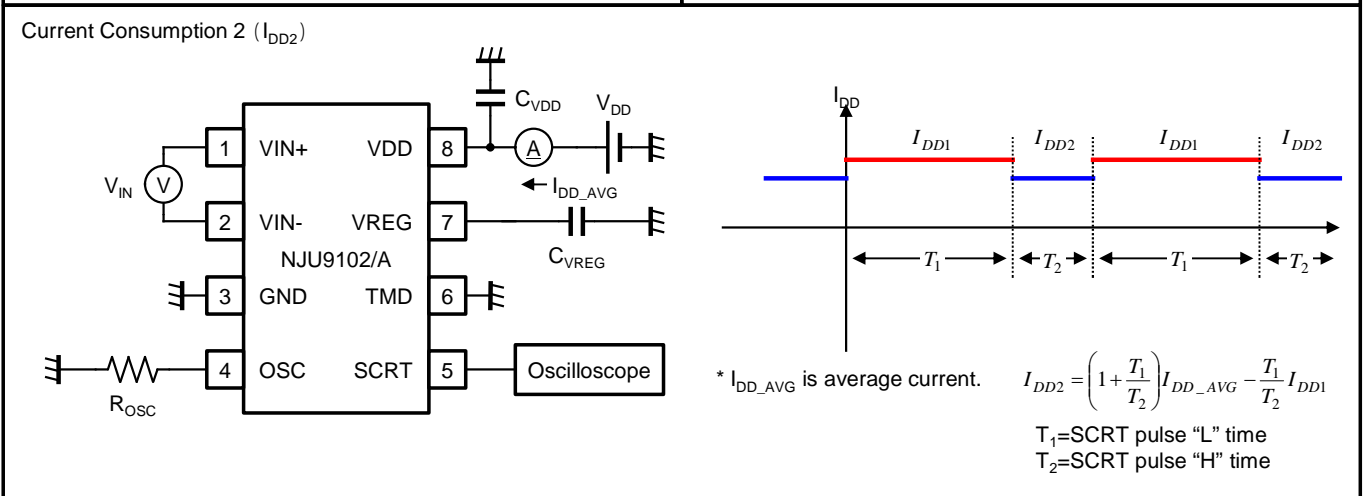
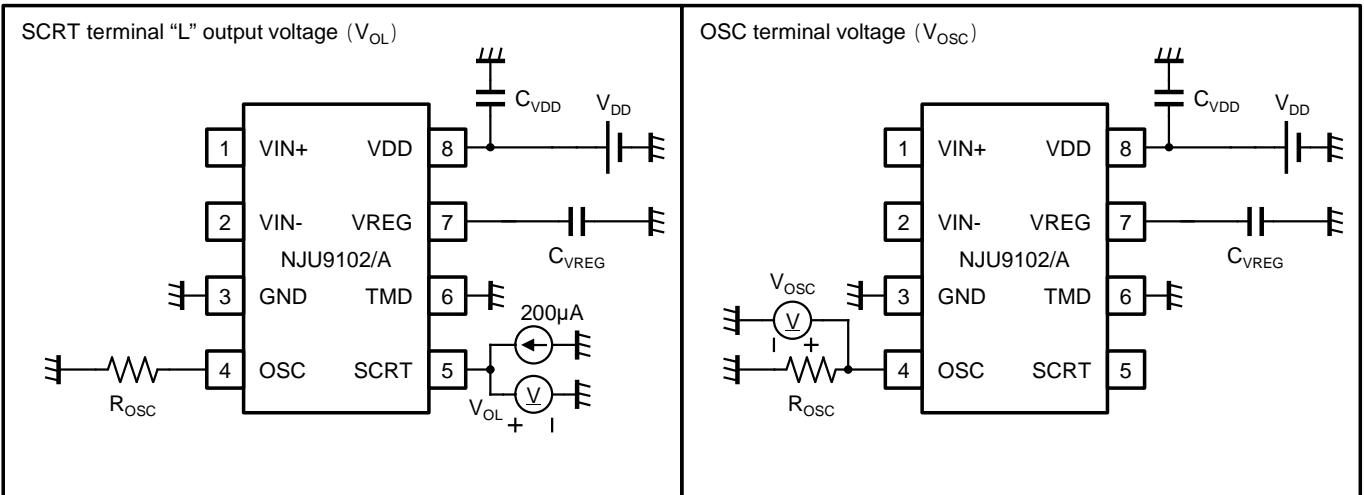

APPLICATION NOTE / GLOSSARY

Earth Leakage Current Detector IC Terminal Description

Earth leakage condition setting terminal : TMD terminal

NJU9102/A sets earth leakage detector condition by the trip pulse by TMD terminal.

“H” : Detector Condition 1 : When NJU9102/A detects the continuous trip pulse of Positive / Negative / Positive (or Negative / Positive / Negative) (AC wave earth leakage detector)

OR

Detector Condition 2 : When NJU9102/A detects two trip pulse of Positive (or Negative) continuously (rectification wave earth leakage detector)

Mode “H” supports Type A. The external pull-up resistor connects with TMD terminal.

NJU9102/A detects the 1st earth leakage signal. And then, NJU9102/A does not generate the trip pulse after periodic judge time until under 0.3125 times of Vtrip.

“L” : Detector Condition 1 : When NJU9102/A detects the continuous trip pulse of Positive / Negative / Positive (or Negative / Positive / Negative) (AC wave earth leakage detector)

Mode “L” supports Type AC. TMD terminal connects to ground directly.

Thyristor control output terminal : SCRT terminal

Thyristor control output SCRT terminal output condition is changed by earth leakage detection condition.

“H” : At earth leakage detection, NJU9102/A outputs an “H” signal from SCRT terminal.

“L” : At standby, NJU9102/A outputs an “L” signal from SCRT terminal.

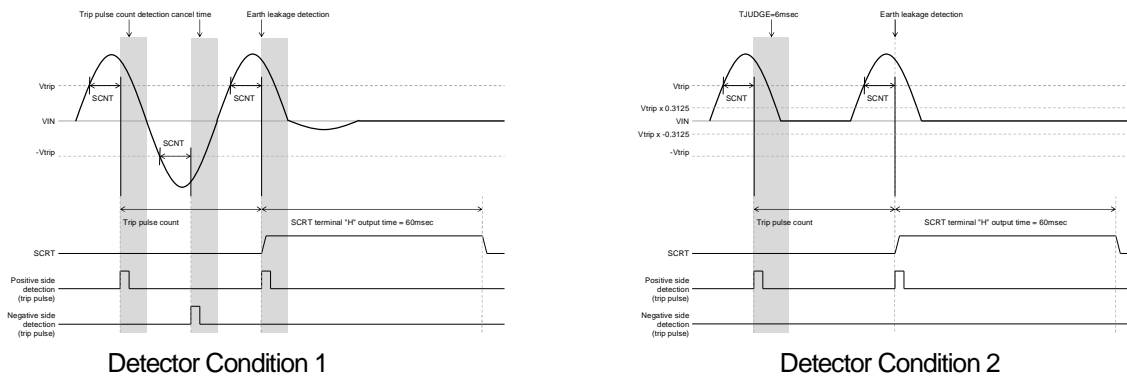

Function Description

Operating Time

When NJU9102/A detects the continuous trip pulse of earth leakage detection condition, NJU9102/A operates at the fast mode that SCRT outputs an “H” signal at an operating time 1.75msec. Then, when input signal over 5 times trip level, SCRT outputs an “H” signal at once (NJU9102 only).

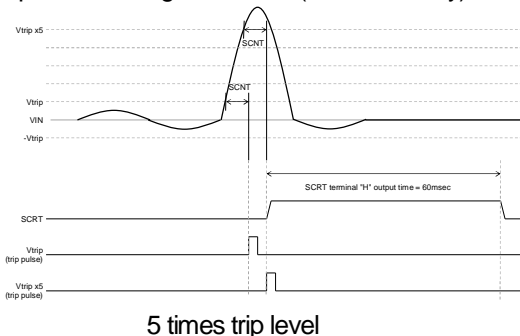

5 times trip level

■Operating Description**1. Power Supply, Input terminal, Clock****1.1 Power Supply**

The VDD terminal and GND terminal of NJU9102/A surely connect. The operating voltage VDD sets to use in the range of electrical characteristics. If VDD reduces a lot, SCR Driver is influenced.

NJU9102/A has a built-in power supply (LDO). A built-in power supply generates 3.3V. VREG terminal is a built-in power supply output terminal. Connect the decoupling capacitors between VREG terminal and GND.

A built-in power supply is used only for NJU9102/A. Do not connect other power supply.

1.2 Input terminal

Input terminals of NJU9102/A, VIN+ terminal and VIN- terminal, connect with the second side of the ZCT.

The second side of the ZCT connects with diode for IC protection.

1.3 Clock

NJU9102/A has a built-in oscillator OSC. OSC provides system clock for digital logic System clock is 293.2kHz. ROSC, which connects with OSC terminal, influences all operations. It is recommended for ROSC to use high precision resistance.

2. ADC data operating

ADC is composed to $\Delta\Sigma$ modulator and digital logic circuit.

2.1 $\Delta\Sigma$ modulator

$\Delta\Sigma$ modulator works over sampling frequency $f_{mod} = 146.6\text{kHz}$.

$\Delta\Sigma$ modulator is composed by second order $\Delta\Sigma$ modulator.

2.2 Sinc3 filter

Digital filter of ADC is Low Pass Filter (LPF) which is Sinc3 filter of third order and decimation ratio is 64.

Output data rate f_{sample} from Sinc3 filter and first notch frequency f_{n1} of filter are the following relations.

$$f_{sample} = \{ f_{mod} / (\text{decimation rate}) \} [\text{SPS}]$$

$$f_{n1} = f_{sample} / 4 [\text{Hz}]$$

The condition is $f_{mod} = 146.6\text{kHz}$ and decimation rate = 64, therefore, each data are below, output data rate $f_{sample} = 2,290.6\text{SPS}$ and first notch frequency $f_{n1} = 572.6\text{Hz}$ and filter cut-off (-3dB) frequency $f_c = 150\text{Hz}$

Maximum folding level is approximately -53dB at 1,400Hz.

Sinc3 filter is initialized to 0V by power on reset at power-on.

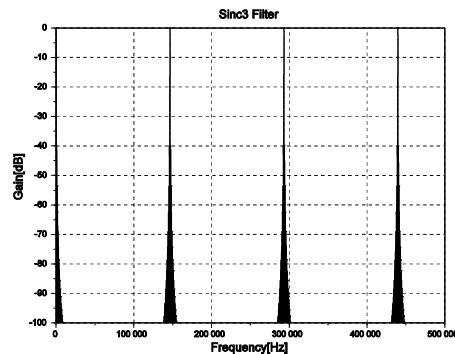
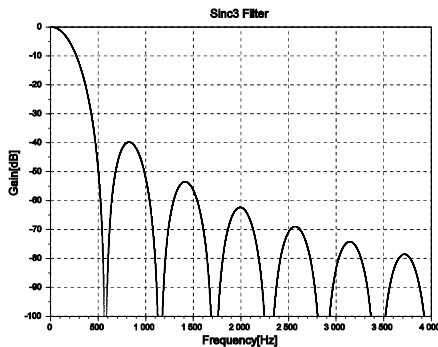

Sinc3 filter specification ($f_{mod} = 146.6\text{kHz}$)

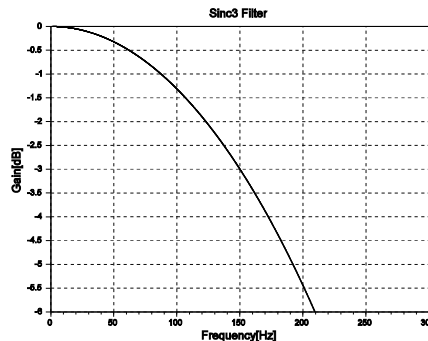

Sinc3 filter specification (Cut off frequency neighborhood)

3. AD conversion operation

After power on reset (PORb) release, NJU9102/A starts AD conversion operation based on system clock. NJU9102/A continues AD conversion operation until earth leakage detection condition (SCRT terminal “H” output).

3.1 AD conversion timing

Period T_{adc} , which operating clock of $\Delta\Sigma$ modulator $f_{mod} = 146.6\text{kHz}$ is divided by decimation rate = 64, is basic unit of AD conversion timing.

$$T_{adc} = \text{decimation rate} / f_{mod} = 0.437 \text{ [msec]}$$

After starting AD conversion operation, conversion data are loaded to ADCDATA register per T_{adc} . Output rate of conversion data is $1 / T_{adc} \text{ [SPS]} = 2,290.6 \text{ [SPS]}$.

Sinc3 filter is initialized to 0V by power on reset. NJU9102/A outputs conversion data per T_{adc} right after AD conversion starts. However, it is $12T_{adc}$ (typical 5.24msec) that Sinc3 filter is completely stable by the input voltage. NJU9102/A outputs conversion data which from first data to 11th data after AD conversion starts during an unstable time from 0V to input voltage. Data from the first data to the 11th data after the conversion output conversion data between an unstable time from 0V to the input voltage.

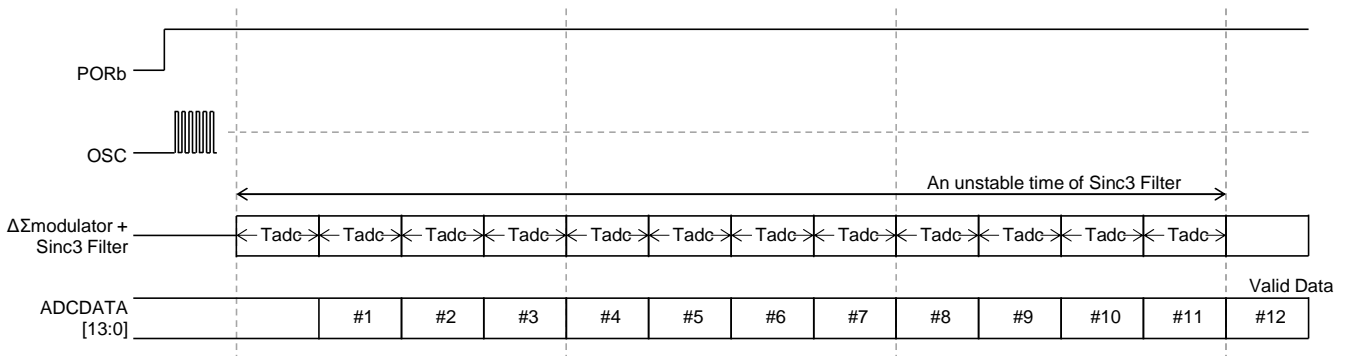

AD conversion start timing

4. Earth Leakage Detection Operation

NJU9102/A detects earth leakage condition by comparing AD conversion data ADCDATA and trip level.

Trip level of NJU9102/A fixes to $\pm 8.4\text{mV}$.

4.1 Trip level generation

ADCDATA overwrites per T_{adc} during AD conversion operation. NJU9102/A compares ADCDATA with trip level = $\pm 8.4\text{mV}$. When ADCDATA absolute value is higher than trip level continuously during sampling count $\text{SCNT} = T_{\text{adc}} \times 4$ times = 1.75msec , NJU9102/A generates trip pulse. When input signal is 60Hz Sine wave, positive side trip pulse and negative side trip pulse are generated.

4.2 Count of trip pulse and judgement of earth leakage

The built in counter counts the number of generated trip pulse. After counting of trip pulse number to adapt a TMD terminal setting, NJU9102/A becomes earth leakage detection condition.

After becoming earth leakage detection condition, output signal from SCRT terminal changes from "L" output signal to "H" output signal. However, when trip pulse is not detected during trip pulse counting and during no signal reset $\text{RJUDGE} =$ approximately 50msec ($T_{\text{adc}} \times 114$ times), the count of trip pulse is reset and SCRT terminal does not output "H" output signal.

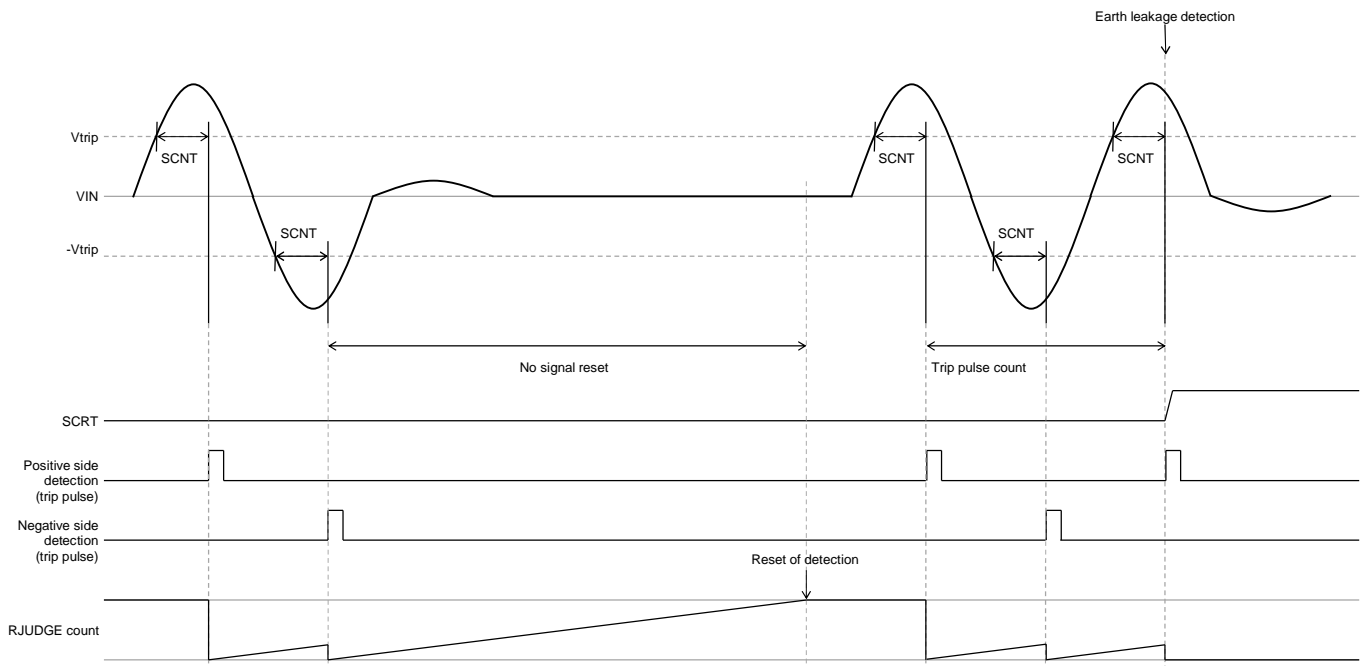

Reset of detection by RJUDGE

4.3 AC wave detection

It supposes that earth leakage current signal is Alternating Current (AC) wave of the commercial frequency. NJU9102/A judges the earth leakage detection when NJU9102/A detects the continuous trip pulse of positive / negative / positive (or negative / positive / negative). TMD terminal sets "L" which supports Type AC.

Trip pulse generator for AC wave detection stops new trip pulse generation until detecting reverse polarity ADCDATA. For example, when positive side trip pulse is generated, NJU9102/A stops to generate trip pulse until ADCDATA value becomes negative value.

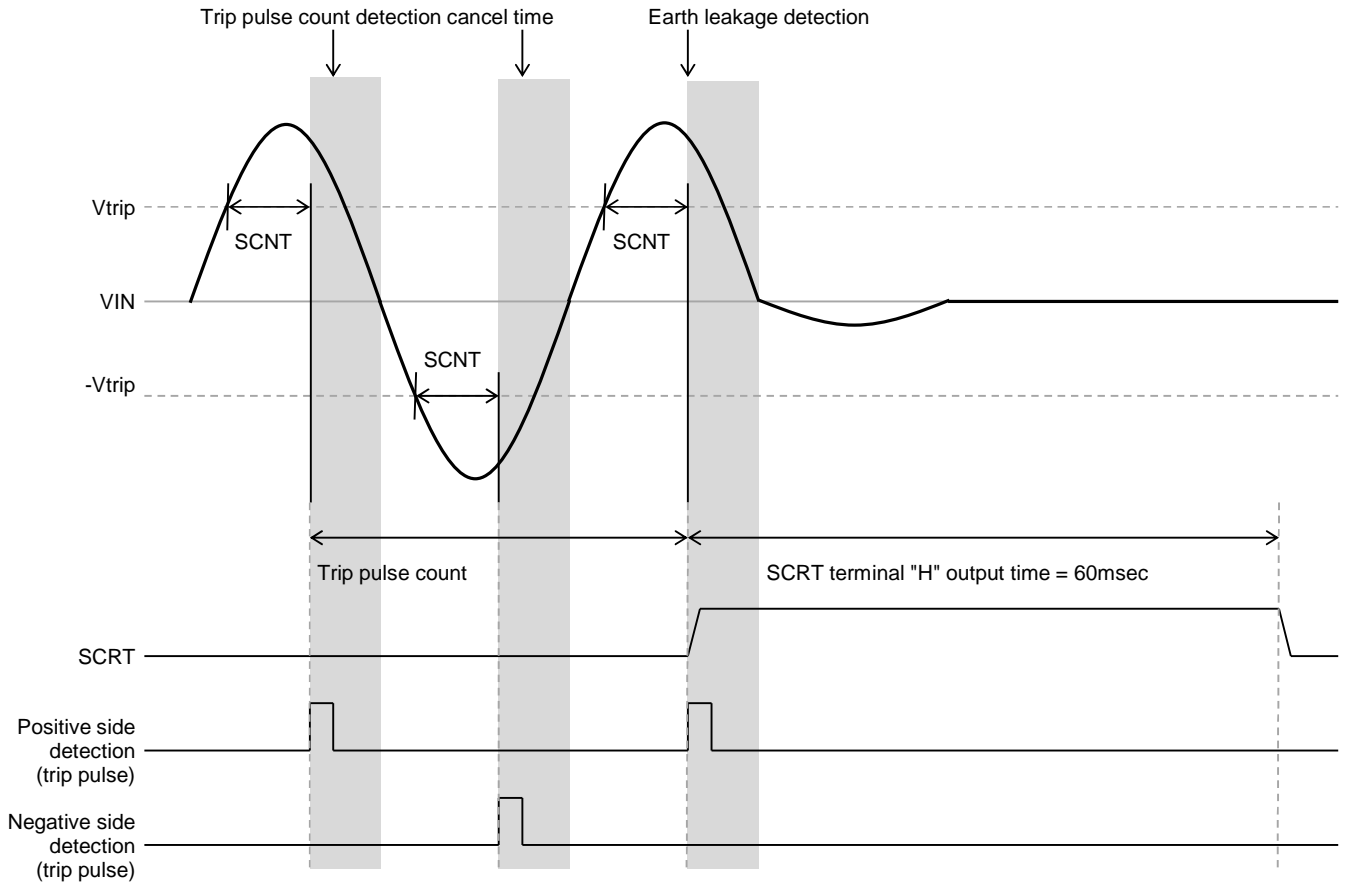

AC wave detection and SCRT output

4.4 DC wave detection

When TMD terminal sets "H" which supports Type A, it becomes effective that earth leakage current signal is Direct Current (DC) wave detection in addition to 4.3 AC wave detection.

Trip pulse generator for DC wave detection stops new trip pulse generation during periodic judge time $T_{JUDGE} = 6\text{msec}$. NJU9102/A becomes earth leakage detection condition by count of positive side trip pulse only or negative side trip pulse only.

After detecting the 1st wave, NJU9102/A stops to generate trip pulse until ADCDATA value becomes 0.3125 times V_{trip} after periodic judge time T_{JUDGE} .

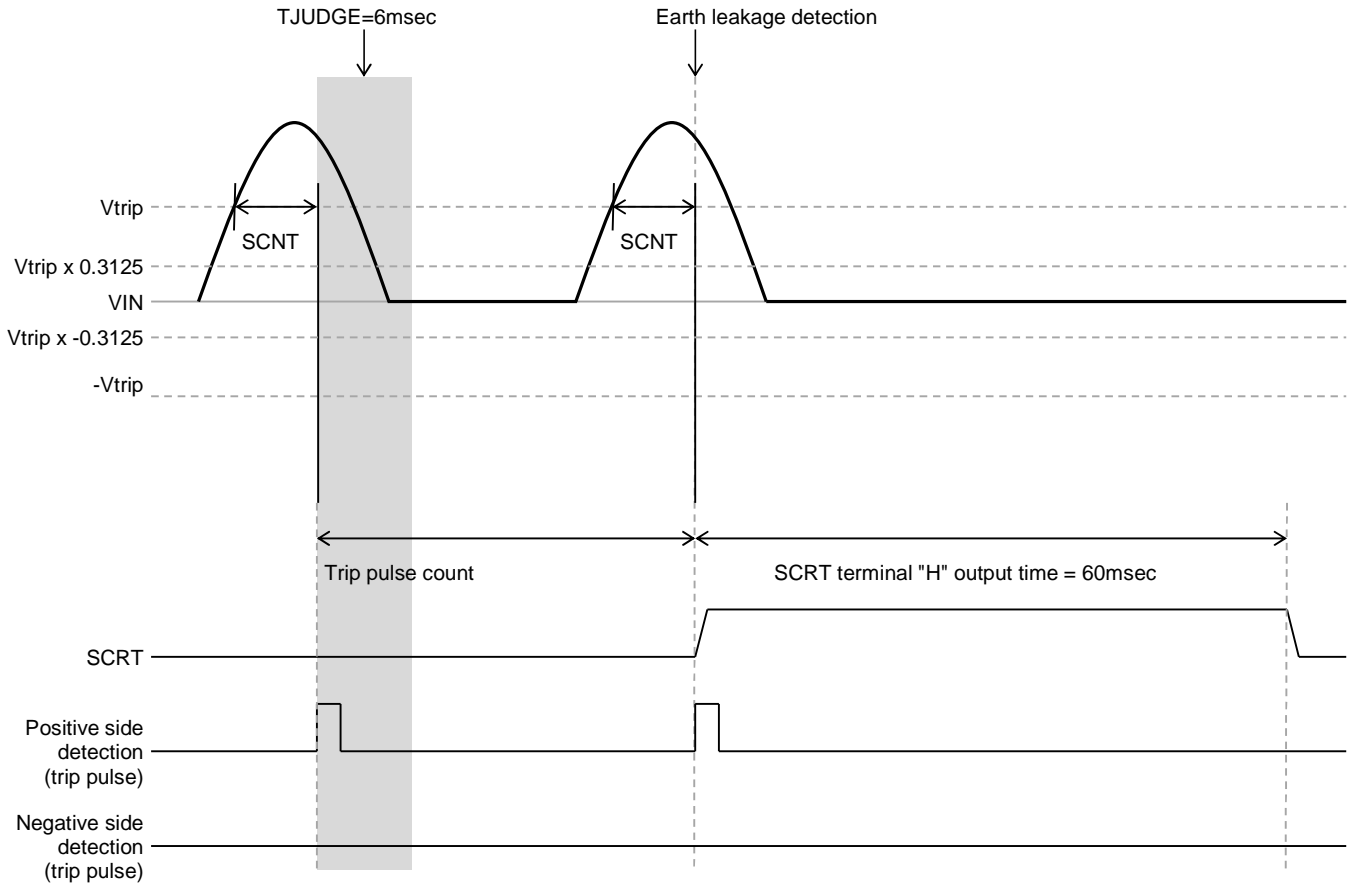

DC wave detection and SCRT output

4.5 Five times trip level detection (NJU9102 only)

NJU9102 compares ADCDATA value with 5 times trip level in addition to normal trip level. NJU9102 generates trip pulse for each detection level.

For the 5 times trip level detection, SCRT terminal outputs "H" output signal immediately at detecting 1st trip pulse without counting trip pulse by setting TMD terminal.

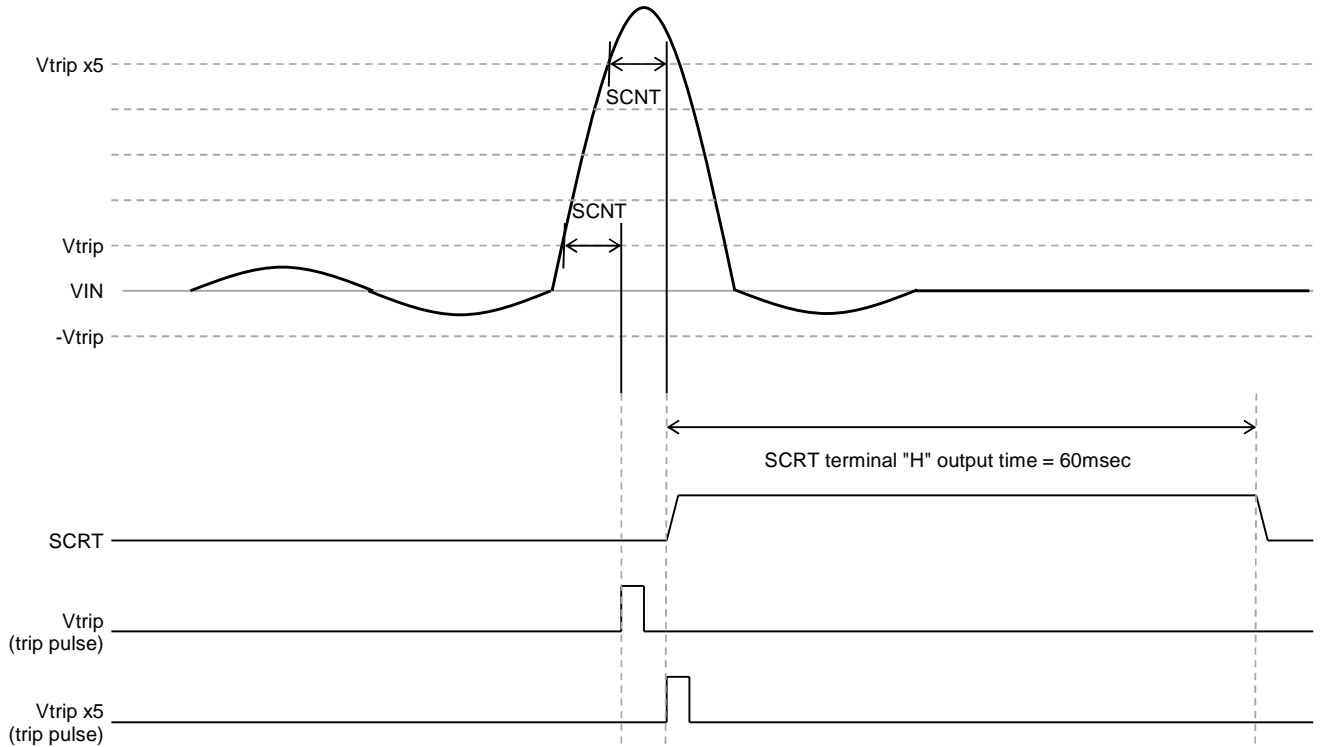

Five times trip level detection and SCRT output

4.6 Earth leakage detection condition circuit

Signal level is judged at trip level comparator by comparing trip level with ADCDATA which is conversion data outputted from Sinc3 filter. The signal level is judged by threshold level of 5 times trip level, too (NJU9102 only).

The judgement result of each level is inputted to SCNT counter which counts the number of over the threshold level and generates trip pulse.

To judge signal level of one time trip level, NJU9102/A has SCNT counter for AC wave detection and SCNT / TJUDGE counter for DC wave detection. The SCNT / TJUDGE counter for DC wave detection counts periodic judge time TJUDGE after generating trip pulse.

Trip pulse to one time trip level is inputted to TMD counter and RJUDGE counter. TMD counter is the trip pulse counter which outputs "H" output signal from SCRT terminal when this counter counts trip pulse to adapt a TMD terminal setting.

To judge signal level of 5 times trip level, NJU9102 has SCNT counter for AC wave detection only. SCNT counter for 5 times trip level does not count trip pulse and NJU9102 becomes earth leakage detection condition by trip pulse detection immediately (NJU9102 only).

When RJUDGE counter does not detect trip pulse during no signal reset RJUDGE, RJUDGE counter resets all trip pulse counters.

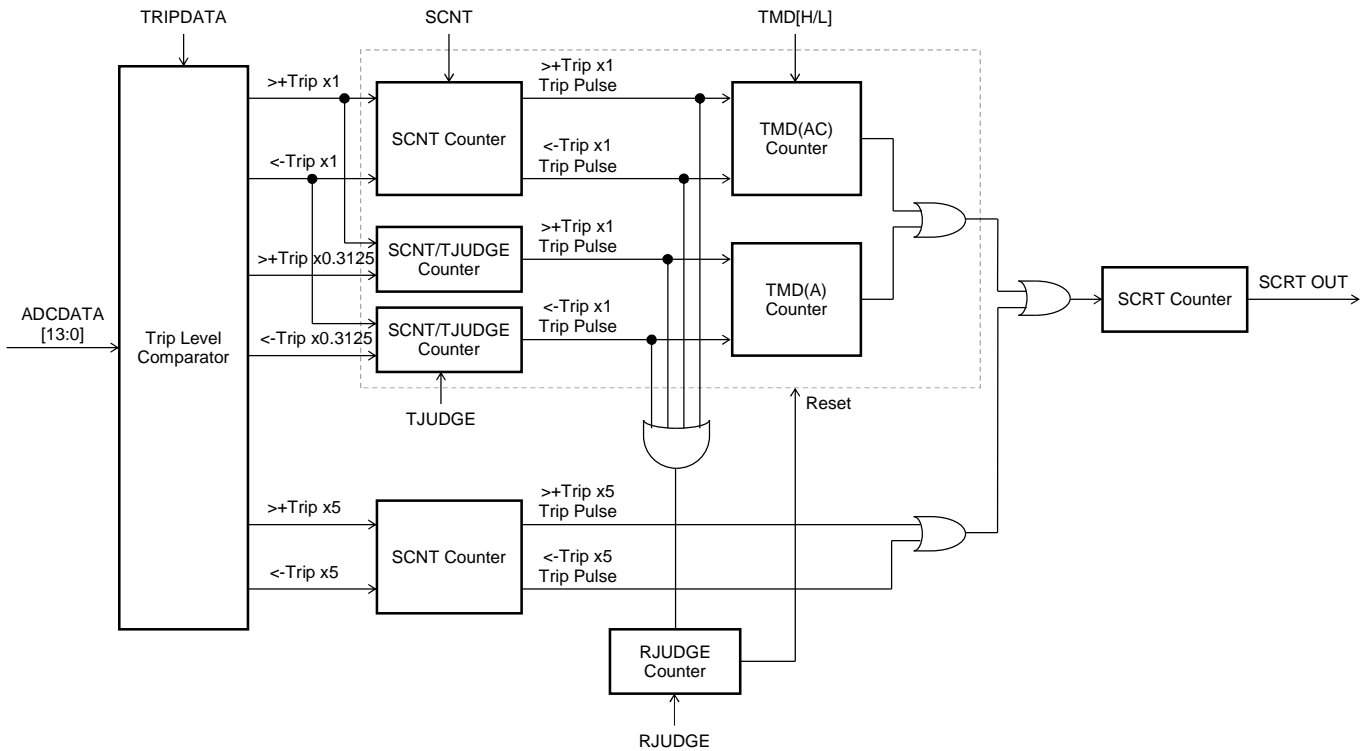

Block diagram of earth leakage detection circuit

5. Operation timing

5.1 Start sequence

After releasing Power On Reset, power down of a built in oscillator OSC is released immediately, OSC starts to operate. After 256 cycle of OSC clock, ADC starts to convert signal. It cancels that modulator outputs MOUT for 20 cycles from starting modulator clock MDCK. NJU9102/A starts to output AD conversion data from 21th cycles MOUT.

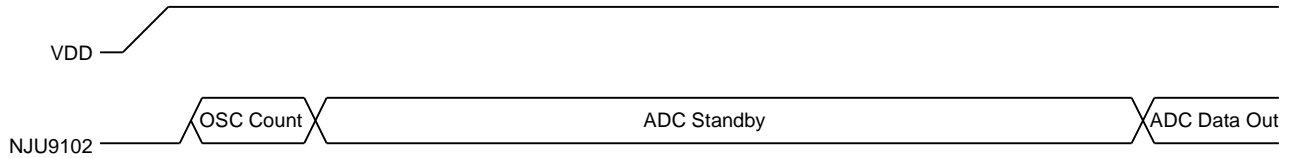

Start sequence

5.2 SCRT output control

When NJU9102/A detects earth leakage detection condition, SCRT terminal outputs an “H” output signal. The SCRT “H” output time is counted by OSC clock.

ADC changes to a power down condition when NJU9102/A outputs an “H” output signal from SCRT terminal.

An “H” output time from SCRT terminal keeps reset timer pulse width $T_{WRET} = 60\text{msec}$. And then, NJU9102/A is reset and SCRT terminal outputs an “L” output signal. NJU9102/A restarts.

At the restart of after SCRT outputs, NJU9102/A restarts to detect the earth leakage current signal after waiting an idling time of 50msec from SCRT fall.

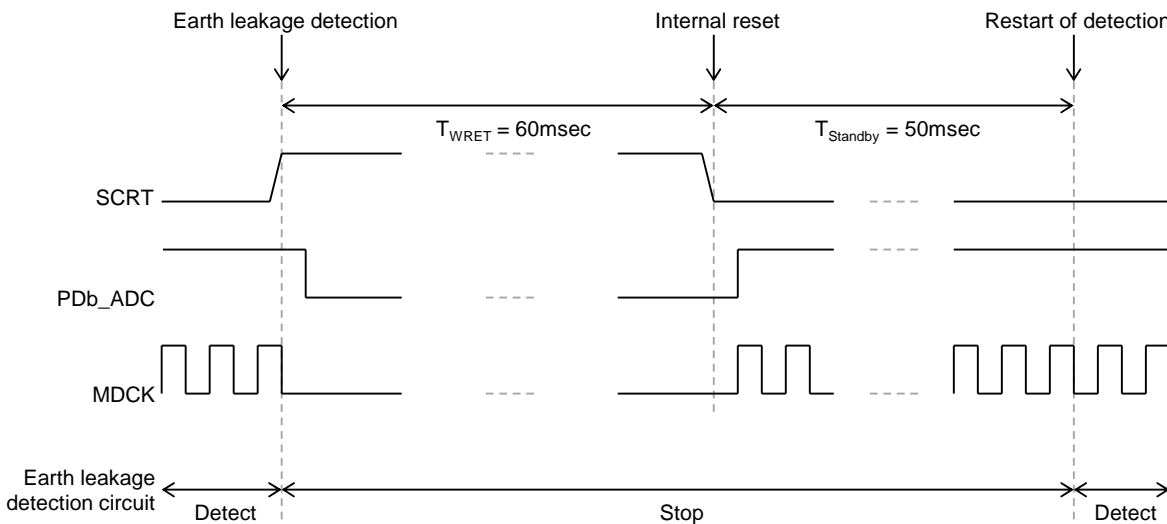

SCRT output control

6. Inrush current control when first turned on

NJU9102/A charges to capacitance CVREG at power supply start. The volume of charge current at power supply start changes by a resistor of the dotted line part on the figure below. The resistor of dotted line part is necessary to control an excessive inrush current.

The target volume of inrush current control is less than 9.6mA.

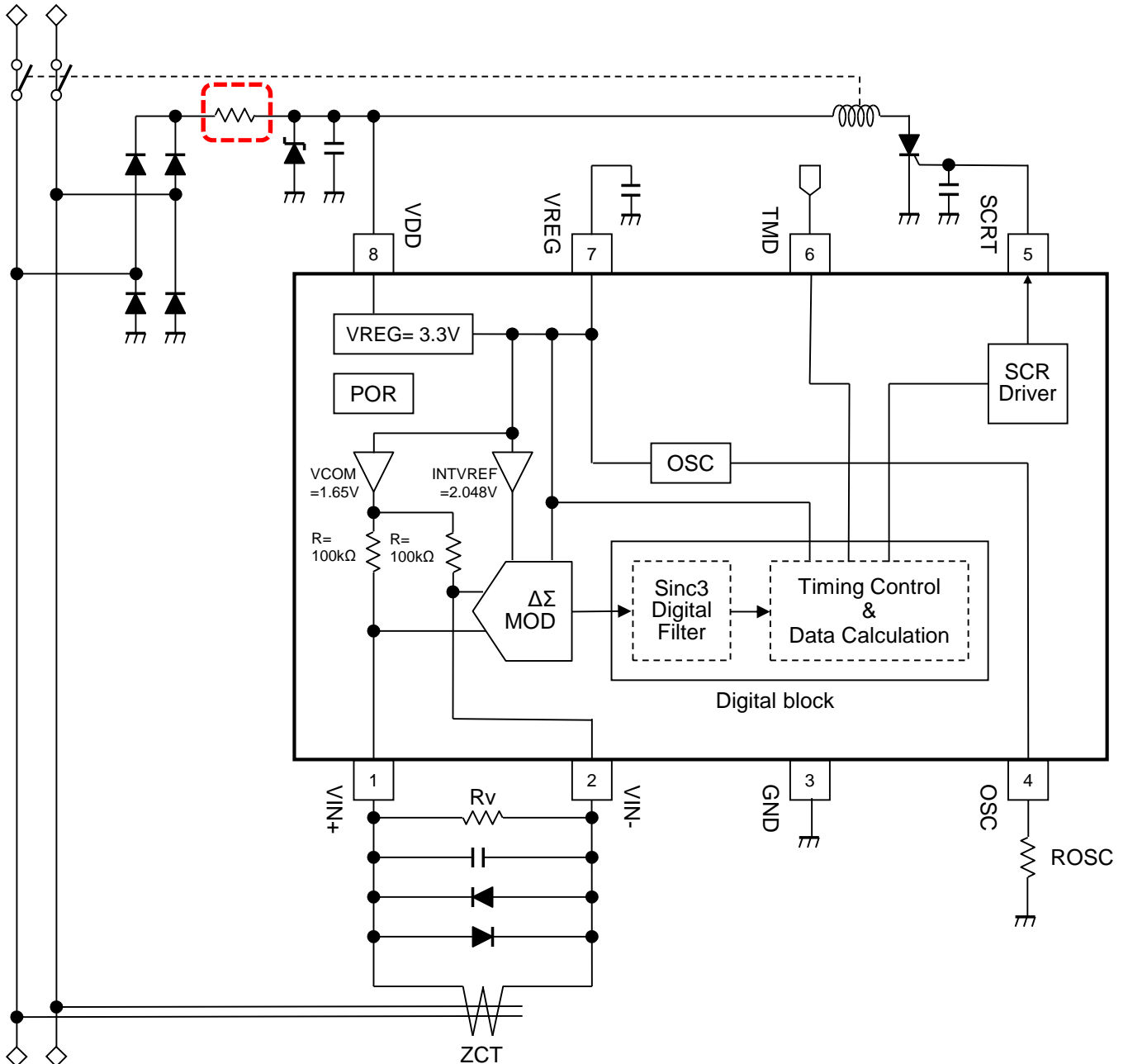

■PACKAGE OUTLINE

DMP8

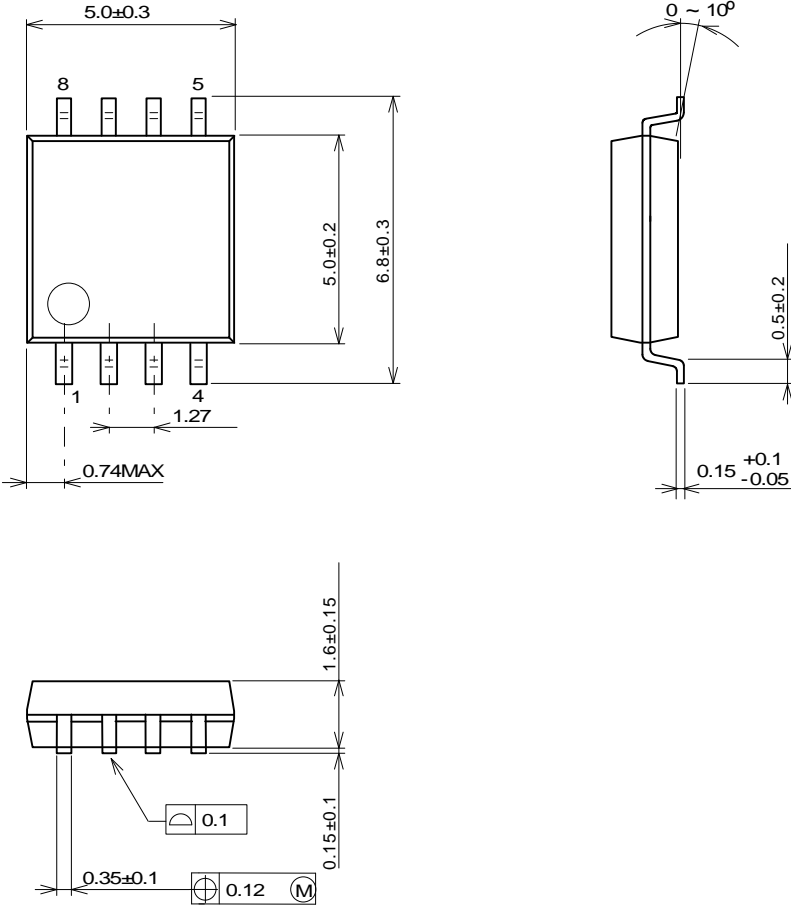

Unit : mm

■SOLDER FOOT PRINT

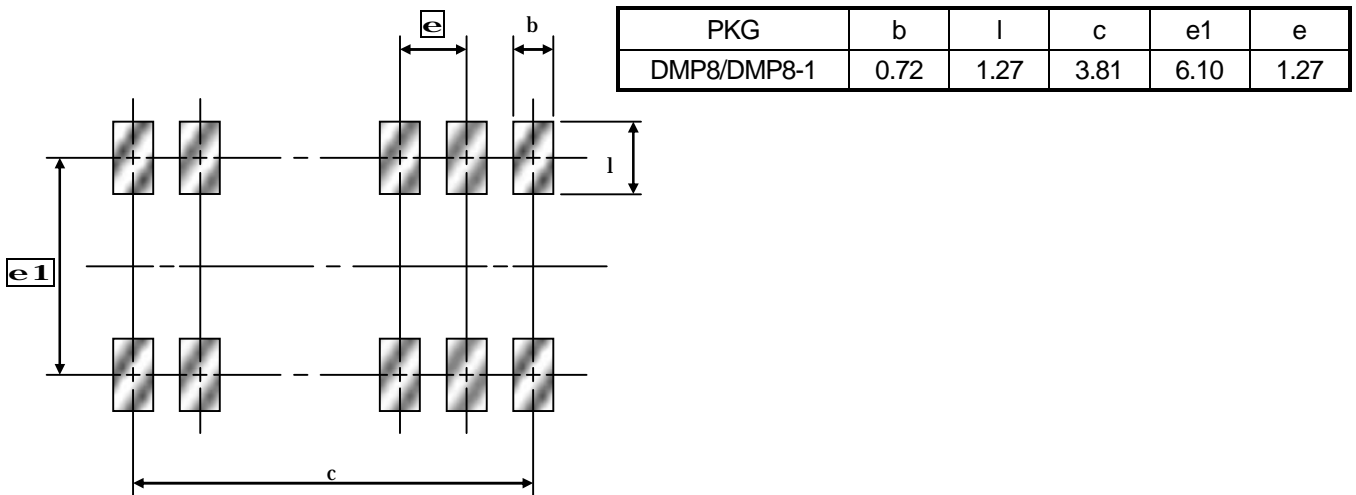

PACKING SPECIFICATION

NJRC delivers ICs in 4 methods, plastic tube container, two kinds of Taping, tray and vinyl bag packing. Except adhesive tape treated anti electrostatic and contain carbon are using as the ESD (Electrostatic Discharge Damage) protection.

DMP Emboss Taping (TE1)

Symbol	DMP8/DMP8-1	DMP14/16/20	Remark
A	7.1	7.4	Bottom size
B	5.4	10.4	Bottom size
D ₀	1.55±0.05	1.5 +0.1/-0	
D ₁	2.05±0.1	1.7±0.1	
E	1.75±0.1	1.75±0.1	
F	7.5±0.1	7.5±0.1	
P ₀	4.0±0.1	4.0±0.1	
P ₁	12.0±0.1	12.0±0.1	
P ₂	2.0±0.1	2.0±0.1	
T	0.3±0.05	0.3±0.05	
T ₂	2.0	2.0	
W	16.0±0.3	16.0±0.3	
W ₁	13.5	13.5	Thickness 0.1MAX

Symbol	DMP8/DMP8-1	DMP14/16/20
A	Ø330±2	
B	Ø80±1	
C	Ø13±0.2	
D	Ø21±0.8	
E	2±0.5	
W	17.5±0.5	
W ₁	2±0.2	
Contents	2,000 pcs	

Unit: mm

Unit: mm

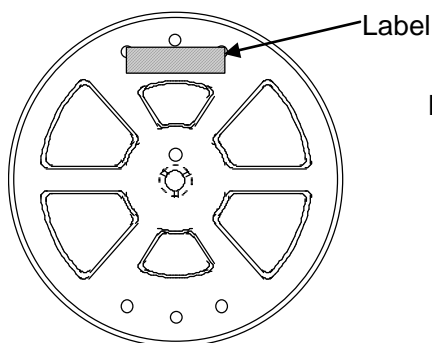
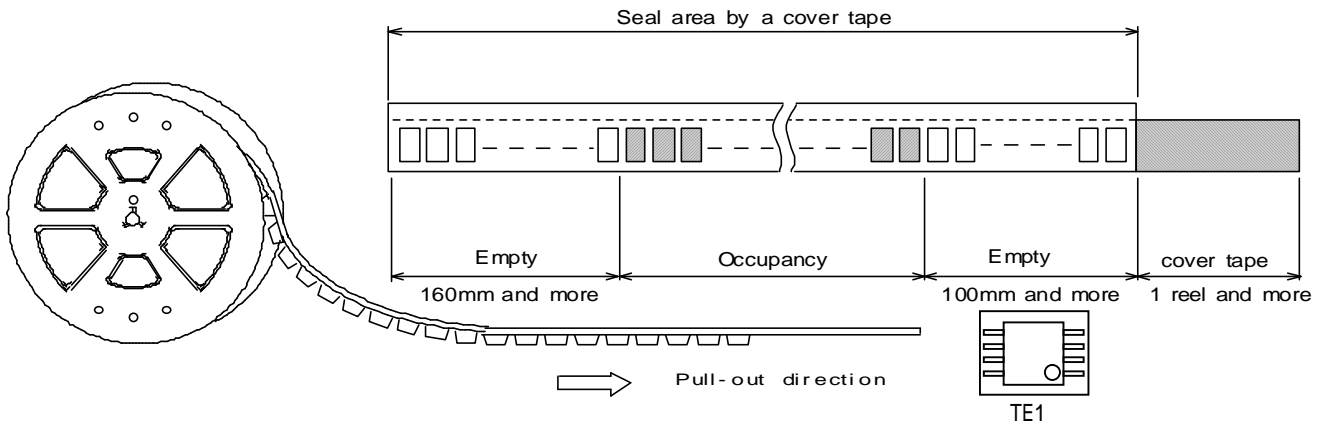
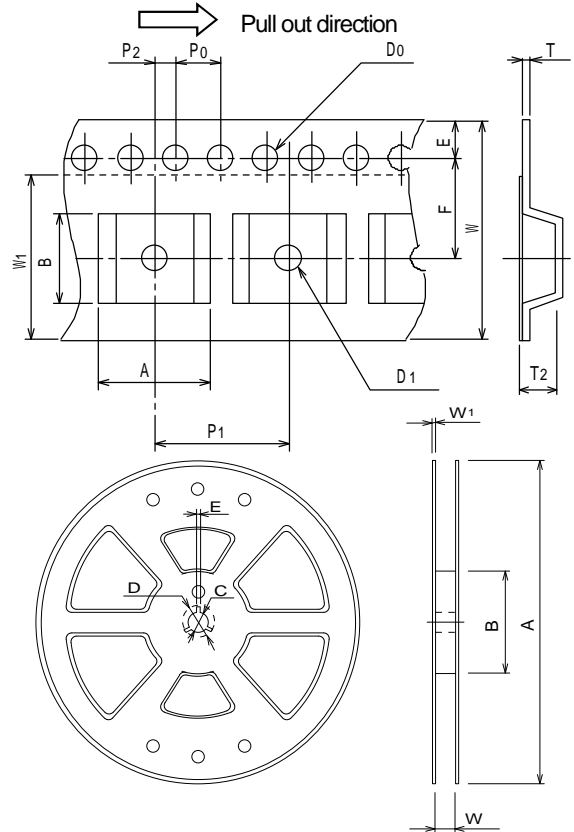

Put in the outer box

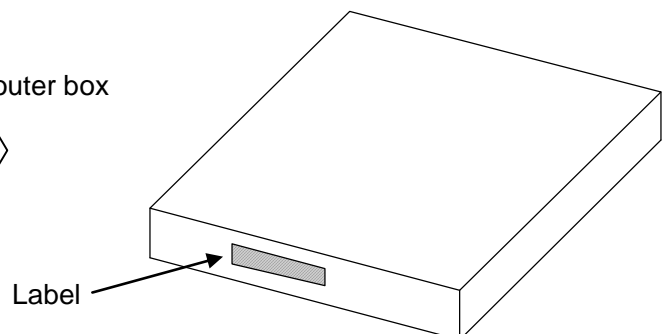
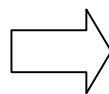

■RECOMMENDED MOUNTING METHOD

INFRARED REFLOW SOLDERING METHOD

Recommended reflow soldering procedure

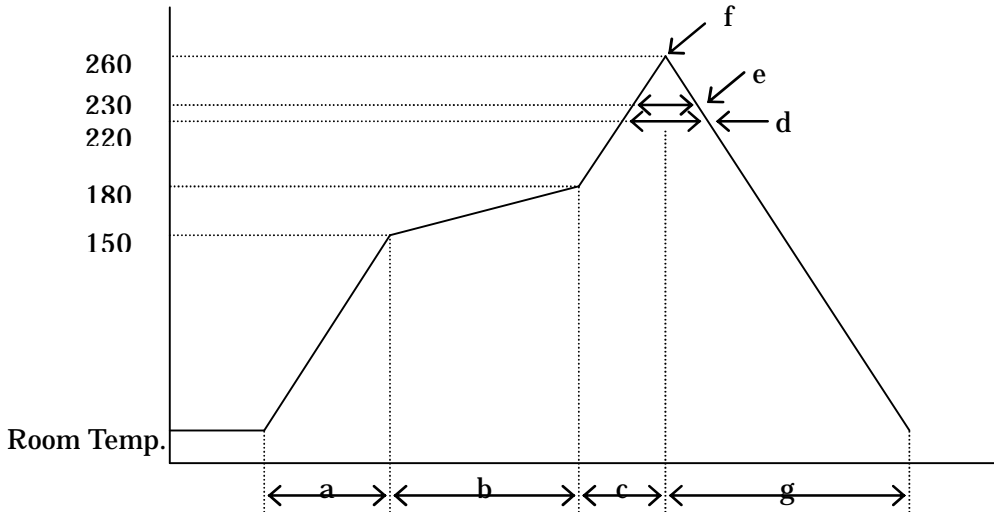

- a : Temperature ramping rate : 1 to 4 /s
- b : Pre-heating temperature : 150 to 180
time : 60 to 120s
- c : Temperature ramp rate : 1 to 4 /s
- d : 220 or higher time : Shorter than 60s
- e : 230 or higher time : Shorter than 40s
- f : Peak temperature : Lower than 260
- g : Temperature ramping rate : 1 to 6 /s

The temperature indicates at the surface of mold package.

[CAUTION]

1. New JRC strives to produce reliable and high quality semiconductors. New JRC's semiconductors are intended for specific applications and require proper maintenance and handling. To enhance the performance and service of New JRC's semiconductors, the devices, machinery or equipment into which they are integrated should undergo preventative maintenance and inspection at regularly scheduled intervals. Failure to properly maintain equipment and machinery incorporating these products can result in catastrophic system failures
2. The specifications on this datasheet are only given for information without any guarantee as regards either mistakes or omissions. The application circuits in this datasheet are described only to show representative usages of the product and not intended for the guarantee or permission of any right including the industrial rights. All other trademarks mentioned herein are property of their respective companies.
3. To ensure the highest levels of reliability, New JRC products must always be properly handled. The introduction of external contaminants (e.g. dust, oil or cosmetics) can result in failures of semiconductor products.
4. New JRC offers a variety of semiconductor products intended for particular applications. It is important that you select the proper component for your intended application. You may contact New JRC's Sale's Office if you are uncertain about the products listed in this catalog.
5. Special care is required in designing devices, machinery or equipment which demand high levels of reliability. This is particularly important when designing critical components or systems whose failure can foreseeably result in situations that could adversely affect health or safety. In designing such critical devices, equipment or machinery, careful consideration should be given to amongst other things, their safety design, fail-safe design, back-up and redundancy systems, and diffusion design.
6. The products listed in the catalog may not be appropriate for use in certain equipment where reliability is critical or where the products may be subjected to extreme conditions. You should consult our sales office before using the products in any of the following types of equipment.

Aerospace Equipment
Equipment Used in the Deep sea
Power Generator Control Equipment (Nuclear, Steam, Hydraulic)
Life Maintenance Medical Equipment
Fire Alarm/Intruder Detector
Vehicle Control Equipment (airplane, railroad, ship, etc.)
Various Safety devices

7. New JRC's products have been designed and tested to function within controlled environmental conditions. Do not use products under conditions that deviate from methods or applications specified in this catalog. Failure to employ New JRC products in the proper applications can lead to deterioration, destruction or failure of the products. New JRC shall not be responsible for any bodily injury, fires or accident, property damage or any consequential damages resulting from misuse or misapplication of its products. Products are sold without warranty of any kind, either express or implied, including but not limited to any implied warranty of merchantability or fitness for a particular purpose.
8. Warning for handling Gallium and Arsenic(GaAs) Products (Applying to GaAs MMIC, Photo Reflector). This Products uses Gallium(Ga) and Arsenic(As) which are specified as poisonous chemicals by law. For the prevention of a hazard, do not burn, destroy, or process chemically to make them as gas or power. When the product is disposed, please follow the related regulation and do not mix this with general industrial waste or household waste.
9. The product specifications and descriptions listed in this catalog are subject to change at any time, without notice.

