



UK2962

Power MOSFET

**SILICON N-CHANNEL MOS
TYPE FIELD EFFECT
TRANSISTOR**

■ **DESCRIPTION**

The UTC **UK2962** is a silicon N-Channel MOS type field effect transistor, it uses UTC's advanced technology to provide the customers with a minimum on state resistance and low leakage current, etc.

The UTC **UK2962** is suitable for chopper regulator, DC-DC converter and motor drive applications.

■ **FEATURES**

- * Low $R_{DS(ON)}$
- * Low leakage current
- * High forward transfer admittance

■ **SYMBOL**

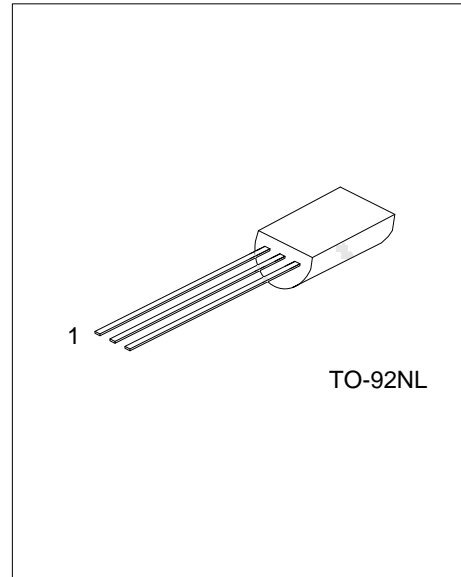
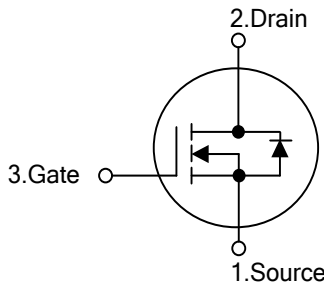

■ **ORDERING INFORMATION**

Ordering Number		Package	Pin Assignment			Packing
Lead Free	Halogen Free		1	2	3	
UK2962L-T9N-B	UK2962G-T9N-B	TO-92NL	S	D	G	Tape Box
UK2962L-T9N-K	UK2962G-T9N-K	TO-92NL	S	D	G	Bulk

Note: Pin Assignment: S: Source D: Drain G: Gate

<p>UK2962G-T9N-B</p> <p>(1)Packing Type</p> <p>(2)Package Type</p> <p>(3)Green Package</p>	<p>(1) B: Tape Box, K: Bulk</p> <p>(2) T9N: TO-92NL</p> <p>(3) G: Halogen Free and Lead Free, L: Lead Free</p>
--	--

■ **MARKING**

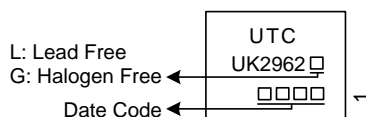

■ ABSOLUTE MAXIMUM RATINGS (T_A=25°C, unless otherwise specified)

PARAMETER	SYMBOL	RATINGS	UNIT
Drain-Source Voltage	V _{DSS}	100	V
Gate-Source Voltage	V _{GSS}	±20	V
Drain Current (Note 1)	DC	I _D	1.0
	Pulse	I _{DP}	3.0
Avalanche Current	I _{AR}	1.0	A
Repetitive Avalanche Energy (Note 3)	E _{AR}	0.09	mJ
Single Pulse Avalanche Energy (Note 2)	E _{AS}	100	mJ
Drain Power Dissipation	P _D	0.9	W
Channel Temperature	T _{CH}	+150	°C
Operating Temperature	T _{OPR}	-40 ~ +150	°C
Storage Temperature Range	T _{STG}	-55 ~ +150	°C

Note: Absolute maximum ratings are those values beyond which the device could be permanently damaged. Absolute maximum ratings are stress ratings only and functional device operation is not implied.

■ THERMAL DATA

PARAMETER	SYMBOL	RATINGS	UNIT
Junction to Ambient	θ _{JA}	138	°C/W

■ ELECTRICAL CHARACTERISTICS (T_A=25°C, unless otherwise specified)

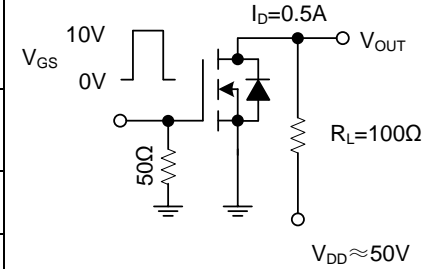
PARAMETER	SYMBOL	TEST CONDITIONS	MIN	TYP	MAX	UNIT	
OFF CHARACTERISTICS							
Drain-Source Breakdown Voltage	BV _{DSS}	I _D =10mA, V _{GS} =0V	100			V	
Drain Cut-Off Current	I _{DSS}	V _{DS} =100V, V _{GS} =0V			100	µA	
Gate-Body Leakage Current	I _{GSS}	V _{GS} =±16V, V _{DS} =0V			±10	µA	
ON CHARACTERISTICS							
Gate Threshold Voltage	V _{GS(TH)}	V _{DS} =10V, I _D =1.0mA	1.3		2.0	V	
Static Drain-Source On-State Resistance	R _{DS(ON)}	V _{GS} =4.0V, I _D =0.5A			0.95	Ω	
		V _{GS} =10V, I _D =0.5A			0.7	Ω	
DYNAMIC PARAMETERS							
Input Capacitance	C _{ISS}	V _{GS} =0V, V _{DS} =10V, f=1.0MHz		510		pF	
Reverse Transfer Capacitance	C _{RSS}			110		pF	
Output Capacitance	C _{OSS}			8		pF	
SWITCHING PARAMETERS							
Total Gate Charge (Gate-Source Plus Gate-Drain)	Q _G	V _{GS} =10V, V _{DD} ≈80V, I _D =1.0A		11		nC	
Gate to Source Charge	Q _{GS}			2		nC	
Gate-Drain ("Miller") Charge	Q _{GD}			1.1		nC	
Turn-ON Time	t _{ON}			4.5		ns	
Rise Time	t _R				16.5		ns
Turn-OFF Time	t _{OFF}				106		ns
Fall-Time	t _F				28		ns
Duty ≤ 1%, t _w = 10µs							

■ ELECTRICAL CHARACTERISTICS (Cont.)

PARAMETER	SYMBOL	TEST CONDITIONS	MIN	TYP	MAX	UNIT
SOURCE- DRAIN DIODE RATINGS AND CHARACTERISTICS						
Continuous Drain Reverse Current (Note 1)	I_{DR}				1.0	A
Pulse Drain Reverse Current (Note 1)	I_{DRP}				3.0	A
Diode Forward Voltage	V_{DSF}	$I_{DR}=1.0A, V_{GS}=0V$			-1.5	V
Reverse Recovery Time	t_{rr}	$I_{DR}=1.0A, V_{GS}=0V, dI_{DR}/dt=50A/\mu s$		49		ns
Reverse Recovery Charge	Q_{rr}			90		nC

Notes: 1. Please use devices on condition that the channel temperature is below 150°C.

2. $V_{DD}=25V, T_{CH}=25^{\circ}C$ (initial), $L=100mH, R_G=25\Omega, I_{AR}=1.4A$.

3. Repetitive rating; Pulse width limited by maximum channel temperature.

■ TEST CIRCUITS AND WAVEFORMS

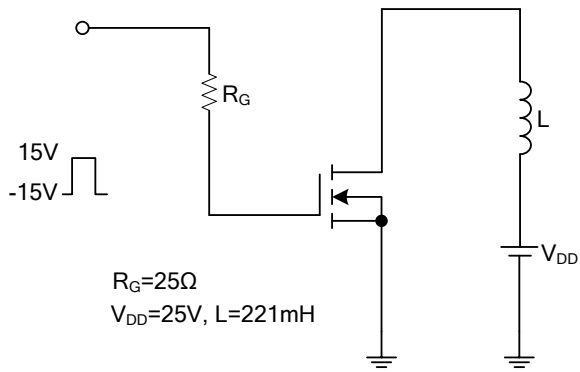

Unclamped Inductive Switching Test Circuit

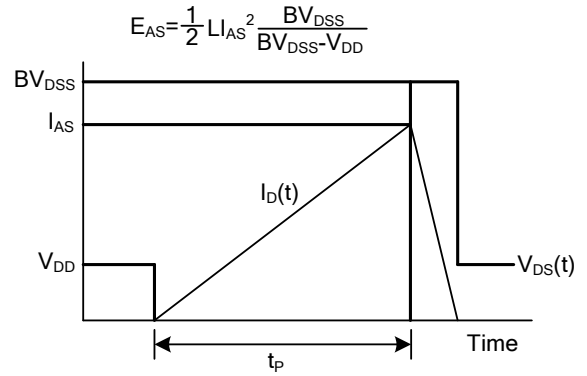

Unclamped Inductive Switching Waveforms

TYPICAL CHARACTERISTICS

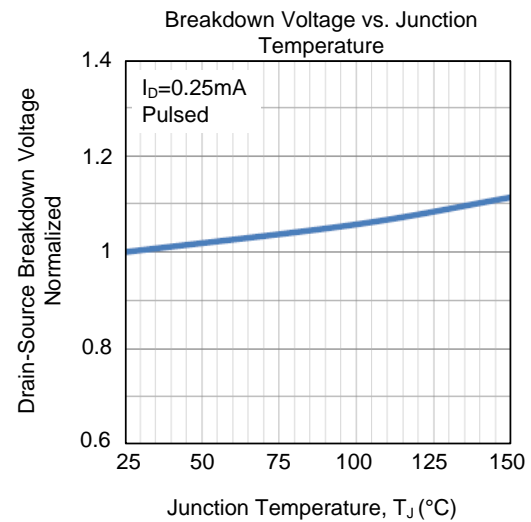
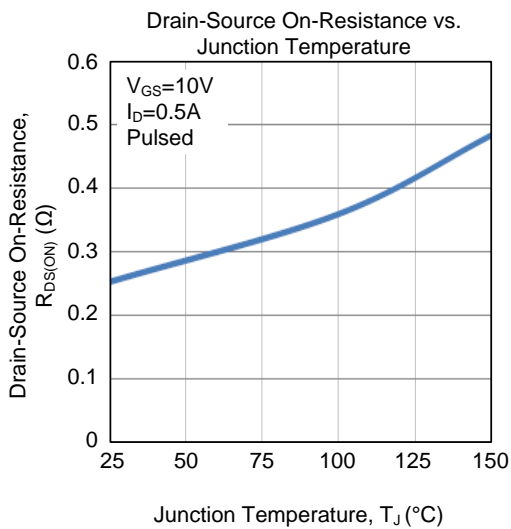
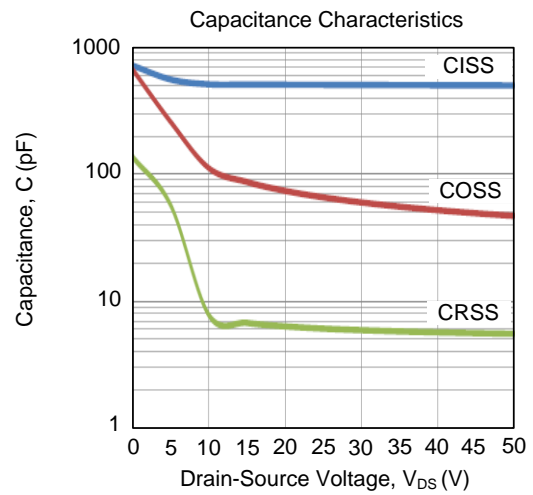
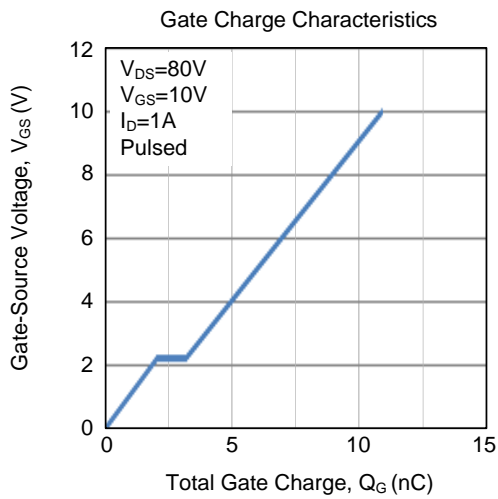
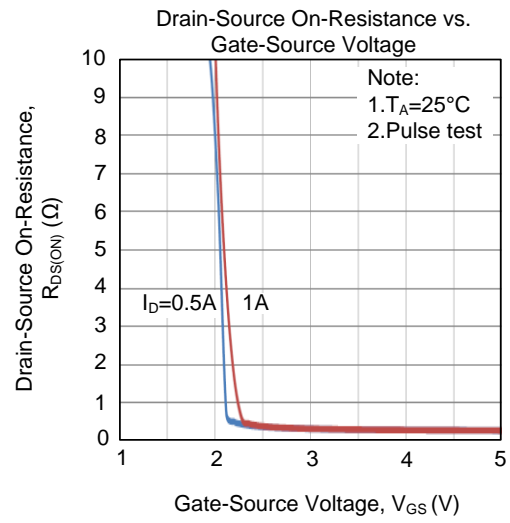
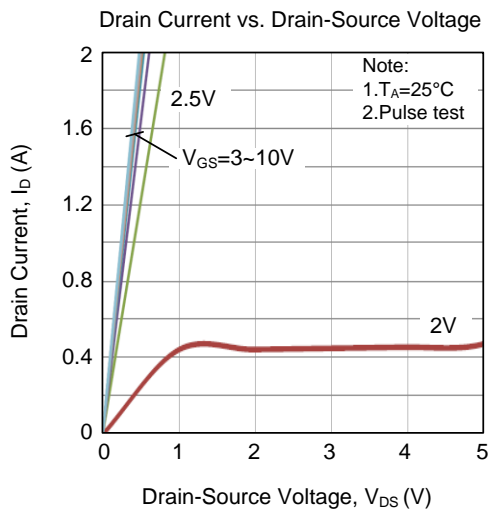

■ TYPICAL CHARACTERISTICS (Cont.)

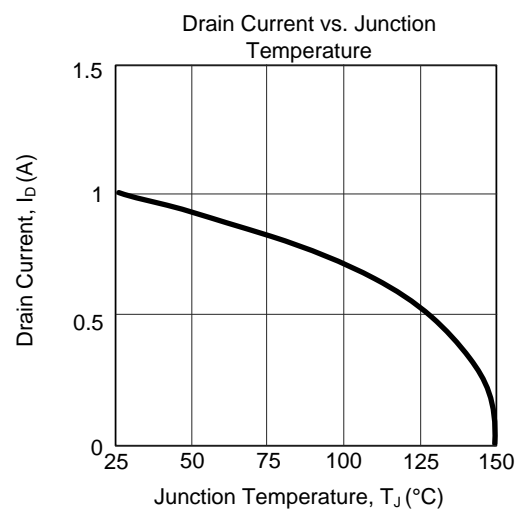
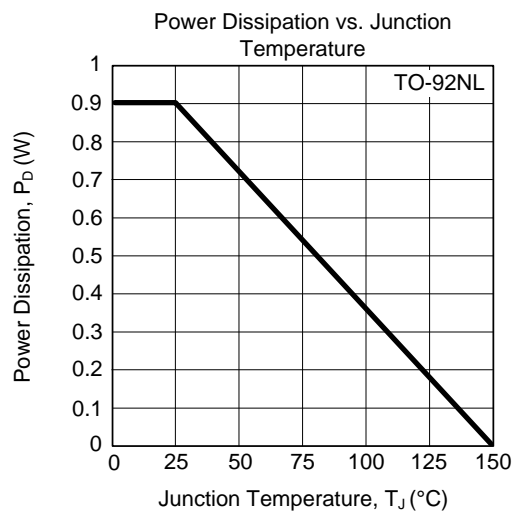
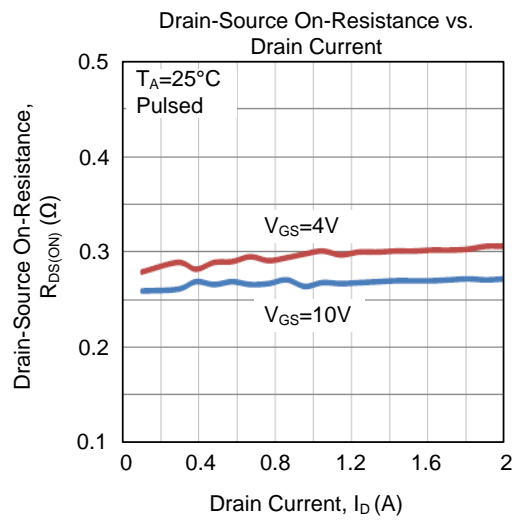
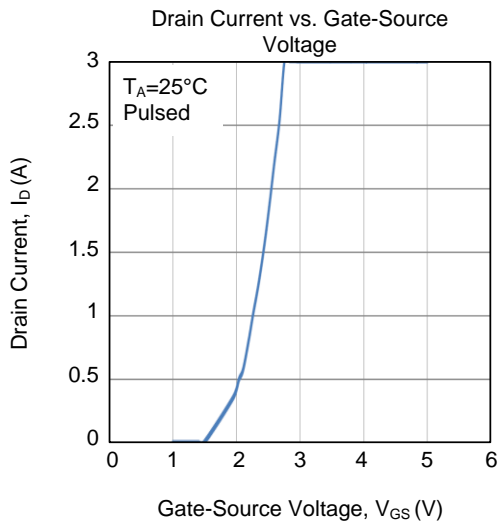
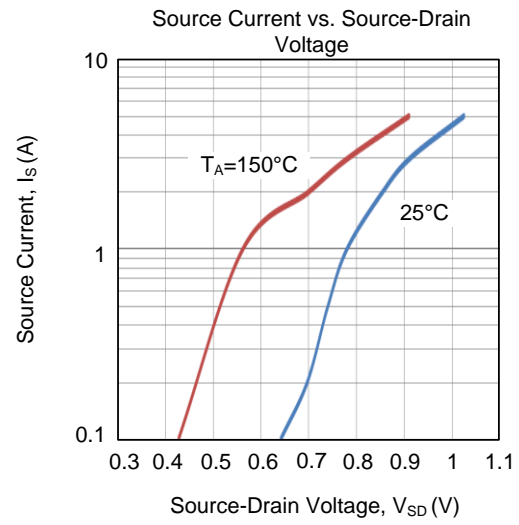
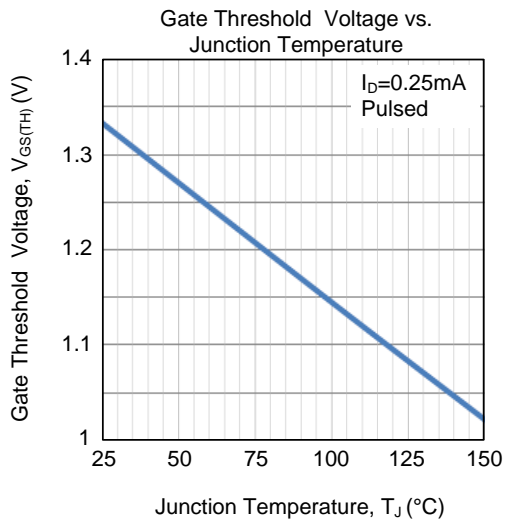

■ TYPICAL CHARACTERISTICS (Cont.)

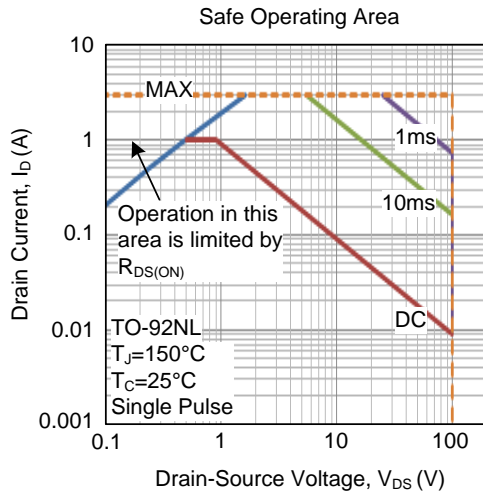

UTC assumes no responsibility for equipment failures that result from using products at values that exceed, even momentarily, rated values (such as maximum ratings, operating condition ranges, or other parameters) listed in products specifications of any and all UTC products described or contained herein. UTC products are not designed for use in life support appliances, devices or systems where malfunction of these products can be reasonably expected to result in personal injury. Reproduction in whole or in part is prohibited without the prior written consent of the copyright owner. UTC reserves the right to make changes to information published in this document, including without limitation specifications and product descriptions, at any time and without notice. This document supersedes and replaces all information supplied prior to the publication hereof.