



2SA1627

PNP SILICON TRANSISTOR

PNP EPITAXIAL SILICON TRANSISTOR

■ DESCRIPTION

The UTC **2SA1627** is designed for general purpose amplifier and high speed switching applications.

■ FEATURES

- *High voltage
- *Low collector saturation voltage.
- *High-speed switching

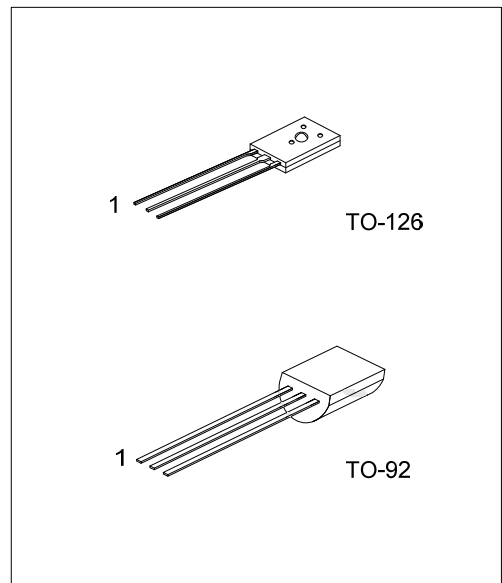

■ ORDERING INFORMATION

Ordering Number		Package	Pin Assignment			Packing
Lead Free	Halogen Free		1	2	3	
2SA1627L-T60-K	2SA1627G-T60-K	TO-126	E	C	B	Bulk
2SA1627L-T92-B	2SA1627G-T92-B	TO-92	E	C	B	Tape Box
2SA1627L-T92-K	2SA1627G-T92-K	TO-92	E	C	B	Bulk

Note: Pin Assignment: E: Emitter C: Collector B: Base

<p>2SA1627G-T60-K</p>	<p>(1) K: Bulk, B: Tape Box (2) T60: TO-126, T92: TO-92 (3) G: Halogen Free and Lead Free, L: Lead Free</p>
-----------------------	---

■ MARKING

TO-126	TO-92

■ ABSOLUTE MAXIMUM RATING ($T_A=25^\circ\text{C}$, unless otherwise specified)

PARAMETER	SYMBOL	RATINGS	UNIT
Collector-Base Voltage	V_{CB0}	-600	V
Collector-emitter voltage	V_{CEO}	-600	V
Emitter-Base Voltage	V_{EBO}	-7.0	V
Collector Current	I_C	-1.0	A
Collector Current (Peak)	I_{CP}	-2.0 (Note 1)	A
Collector Dissipation	TO-126	P_C	1
	TO-92		0.6
Junction Temperature	T_J	+150	$^\circ\text{C}$
Storage Temperature	T_{STG}	-55 ~ +150	$^\circ\text{C}$

Notes: 1. Absolute maximum ratings are those values beyond which the device could be permanently damaged.
 Absolute maximum ratings are stress ratings only and functional device operation is not implied.
 2. $P_W \leq 10\text{ms}$, Duty Cycle $\leq 50\%$.

■ ELECTRICAL CHARACTERISTICS ($T_A=25^\circ\text{C}$, unless otherwise specified)

PARAMETER	SYMBOL	TEST CONDITIONS	MIN	TYP	MAX	UNIT
Collector Cut-Off Current	I_{CBO}	$V_{CB} = -600\text{V}$, $I_E = 0$			-10	μA
Emitter Cut-Off Current	I_{EBO}	$V_{EB} = -7.0\text{V}$, $I_C = 0$			-10	μA
DC Current Gain (Note)	h_{FE1}	$V_{CE} = -5.0\text{V}$, $I_C = -0.1\text{A}$	30	58	120	
	h_{FE2}	$V_{CE} = -5.0\text{V}$, $I_C = -0.5\text{A}$	5	19		
Collector-Emitter Saturation Voltage (Note)	$V_{CE(sat)}$	$I_C = -0.3\text{A}$, $I_B = -0.06\text{A}$		-0.28	-0.5	V
Base-Emitter Saturation Voltage (Note)	$V_{BE(sat)}$	$I_C = -0.3\text{A}$, $I_B = -0.06\text{A}$		-0.85	-1.2	V
Gain Bandwidth Product	f_T	$V_{CE} = -10\text{V}$, $I_E = 0.1\text{A}$	10	28		MHz
Output Capacitance	C_{ob}	$V_{CB} = -10\text{V}$, $I_E = 0$, $f = 1.0\text{MHz}$		42	50	pF
Turn-On Time	t_{on}	$I_C = -0.5\text{A}$, $R_L = 500\Omega$ $I_{B1} = -I_{B2} = -0.1\text{A}$ $V_{CC} = -250\text{V}$		0.1	0.5	μs
Storage Time	T_{STG}			3.5	5.0	μs
Fall Time	t_f			0.08	0.5	μs

Note: Pulse test: Pulse width=300 μs , Duty Cycle $\leq 2\%$

■ CLASSIFICATION OF h_{FE1}

RANK	M	L	K
RANGE	30 ~ 60	40 ~ 80	60 ~ 120

TYPICAL CHARACTERISTICS

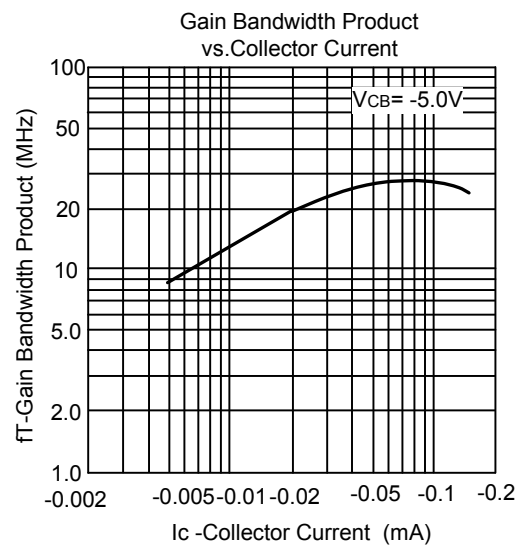
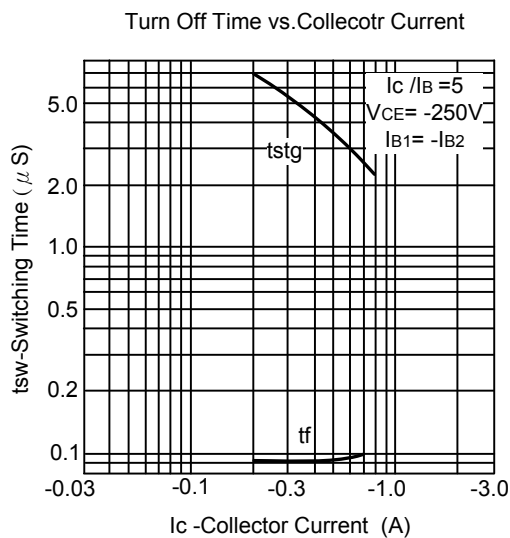
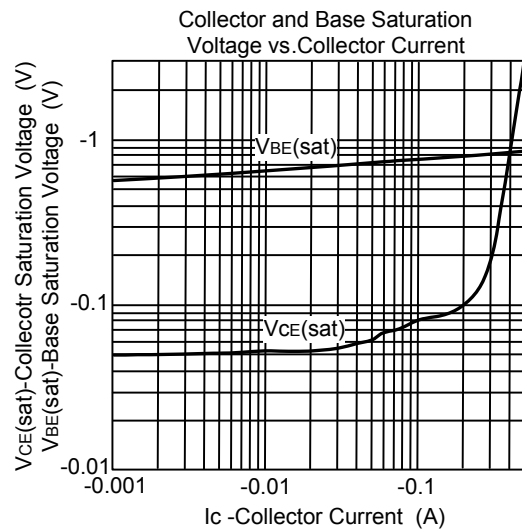
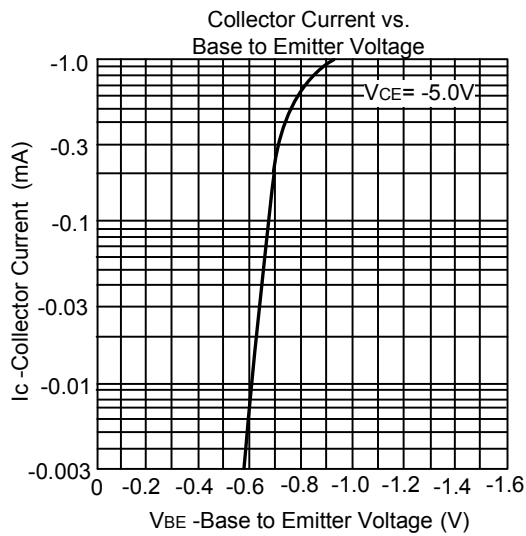
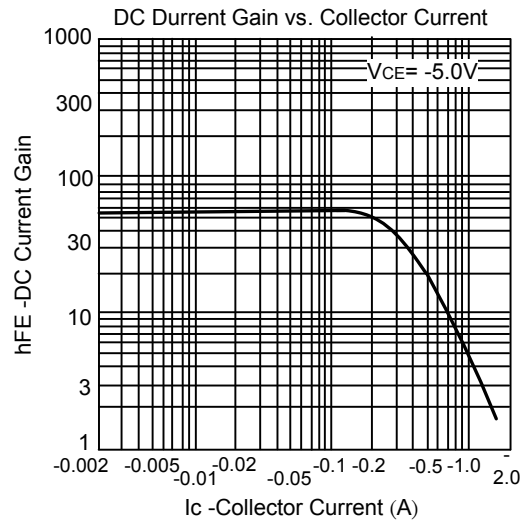
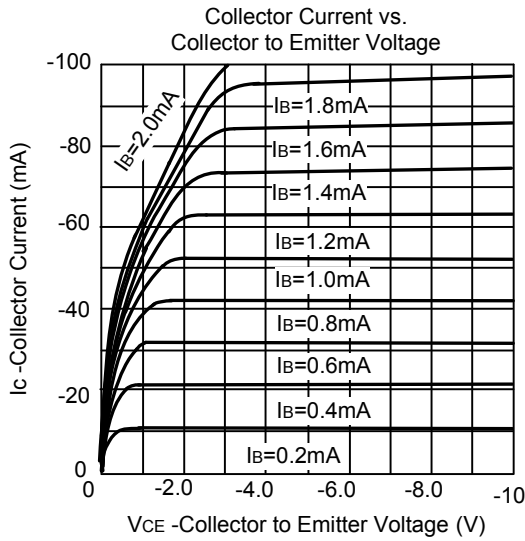

■ TYPICAL CHARACTERISTICS (Cont.)

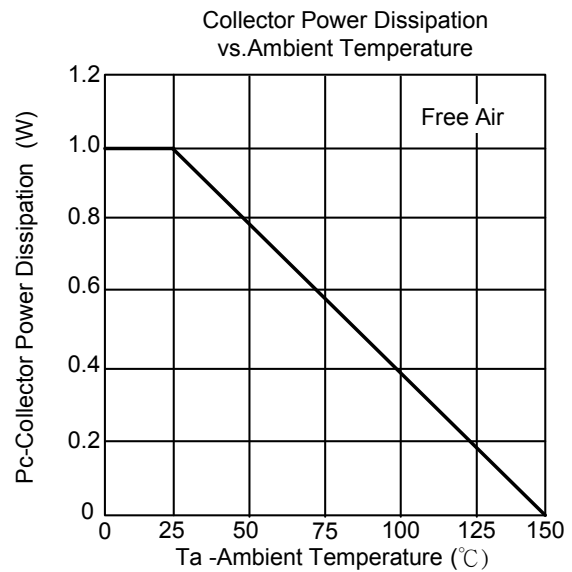
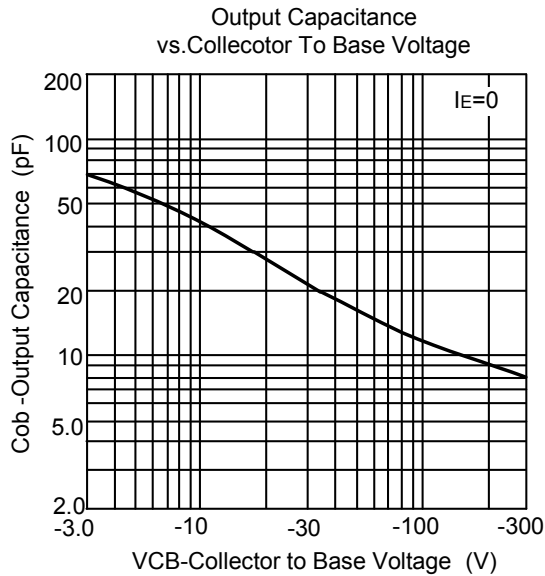

UTC assumes no responsibility for equipment failures that result from using products at values that exceed, even momentarily, rated values (such as maximum ratings, operating condition ranges, or other parameters) listed in products specifications of any and all UTC products described or contained herein. UTC products are not designed for use in life support appliances, devices or systems where malfunction of these products can be reasonably expected to result in personal injury. Reproduction in whole or in part is prohibited without the prior written consent of the copyright owner. UTC reserves the right to make changes to information published in this document, including without limitation specifications and product descriptions, at any time and without notice. This document supersedes and replaces all information supplied prior to the publication hereof.