

Specifications for

Blanview TFT-LCD Monitor

Version 1.0

MODEL COM22H2P69ULC

(Please be sure to check the specifications latest version.)

Customer's Approval

Signature:

Name:

Section:

Title:

Date:

ORTUSTECH

TOPPAN PRINTING CO.,LTD.

Electronics Division

Ortus Subdivision

Approved by

_____ *Y. Nakajima*

Checked by

_____ *S. Kuwayama*

Prepared by

_____ *M. Shibamoto*

Version History

Ver.	Date	Page	Description
1.0	Feb.13,2020	-	-
			First issue

Contents

1. Application	4
2. Outline Specifications		
2.1 Features of the Product	5
2.2 Display Method	5
3. Dimensions and Shape		
3.1 Dimensions	5
3.2 Outward Form	7
3.3 Serial No. print (S-print)	8
4. Pin Assignment	9
5. Block Diagram	10
6. Absolute Maximum Rating	11
7. Recommended Operating Conditions	13
8. Characteristics		
8.1 DC Characteristics	12
8.2 AC Characteristics		
8.2.1 System I/F Timing Characteristics	13
8.2.2 Reset Timing Chart	14
9. Interface		
9.1 Interface mode	15
9.2 System interface timing	16
10. Register List	17
11. Sequence		
11.1 Power-ON Sequence	20
11.2 Power-OFF Sequence	21
11.3 Deep-Standby Sequence	21
11.4 Deep-Standby Release Sequence	21
11.5 Refresh Sequence	22
11.6 Power Supply ON Sequence	23
11.7 Power Supply OFF Sequence	23
12. LED Circuit	23
13. Characteristics		
13.1 Optical Characteristics	24
13.2 Temperature Characteristics	25
13.3 Service Life of Backlight	25
14. Criteria of Judgment		
14.1 Defective Display and Screen Quality	26
14.2 Screen and Other Appearance	27
15. Reliability Test	28
16. Packing Specifications	30
17. Handling Instruction		
17.1 Cautions for Handling LCD panels	31
17.2 Precautions for Handling	32
17.3 Precautions for Operation	32
17.4 Storage Condition for Shipping Cartons	33
17.5 Precautions for Peeling off the Protective film	34
17.6 Warranty	34
APPENDIX	35

1. Application

This Specification is applicable to 56.4mm (2.2 inch) Blanview TFT-LCD monitor for non-military use.

- ◎ TOPPAN PRINTING makes no warranty or assume no liability that use of this Product and/or any information including drawings in this Specification by Purchaser is not infringing any patent or other intellectual property rights owned by third parties, and TOPPAN PRINTING shall not grant to Purchaser any right to use any patent or other intellectual property rights owned by third parties. Since this Specification contains TOPPAN PRINTING's confidential information and copy right, Purchaser shall use them with high degree of care to prevent any unauthorized use, disclosure, duplication, publication or dissemination of TOPPAN PRINTING's confidential information and copy right.
- ◎ If Purchaser intends to use this Products for an application which requires higher level of reliability and/or safety in functionality and/or accuracy such as transport equipment (aircraft, train, automobile, etc.), disaster-prevention/security equipment or various safety equipment, Purchaser shall consult TOPPAN PRINTING on such use in advance.
- ◎ This Product shall not be used for application which requires extremely higher level of reliability and/or safety such as aerospace equipment, telecommunication equipment for trunk lines, control equipment for nuclear facilities or life-support medical equipment.
- ◎ It must be noted as an mechanical design manner, especial attention in housing design to prevent arcuation/flexure or caused by stress to the LCD module shall be considered.
- ◎ TOPPAN PRINTING assumes no liability for any damage resulting from misuse, abuse, and/or miss-operation of the Product deviating from the operating conditions and precautions described in the Specification.
- ◎ TOPPAN PRINTING is not responsible for any nonconformities and defects that are not specified in this specifications.
- ◎ If any issue arises as to information provided in this Specification or any other information, TOPPAN PRINTING and Purchaser shall discuss them in good faith and seek solution.
- ◎ TOPPAN PRINTING assumes no liability for defects such as electrostatic discharge failure occurred during peeling off the protective film or Purchaser's assembly process.
- ◎ This Product is compatible for RoHS(2.0) directive.

Object substance	Maximum content [ppm]
Cadmium and its compound	100
Hexavalent Chromium Compound	1000
Lead & Lead compound	1000
Mercury & Mercury compound	1000
Polybrominated biphenyl series (PBB series)	1000
Polybrominated biphenyl ether series (PBDE series)	1000
Bis(2-ethylhexyl)phthalate series(DEHP series)	1000
Butyl benzyl phthalate series(BBP series)	1000
Dibutyl phthalate series(DBP series)	1000
Diisobutyl phthalate series(DIBP series)	1000

2. Outline Specifications

2.1 Features of the Product

- 2.2 inch diagonal display, 240 x RGB [H] x 320 [V] dots.
- 6-bit / 262,144 colors.
- Single power supply 2.8V
- Timing generator [TG], Counter-electrode driving circuitry, Built-in power supply circuit.
- High bright white LED back-light.

2.2 Display Method

Items	Specifications	Remarks
Display type	VA 262,144 colors. Blanview, Normally black.	Color filter NTSC ratio : 35%
Product description	LCD monitor with internal CPU interface circuit	
Driving method	a-Si TFT Active matrix. Line-scanning, Non-interlace.	
Dot arrangement	RGB stripe arrangement.	Refer to "Dot arrangement"
Signal input method	System interface with 18 bit bus width	
Backlight	High brightness LED, side light	

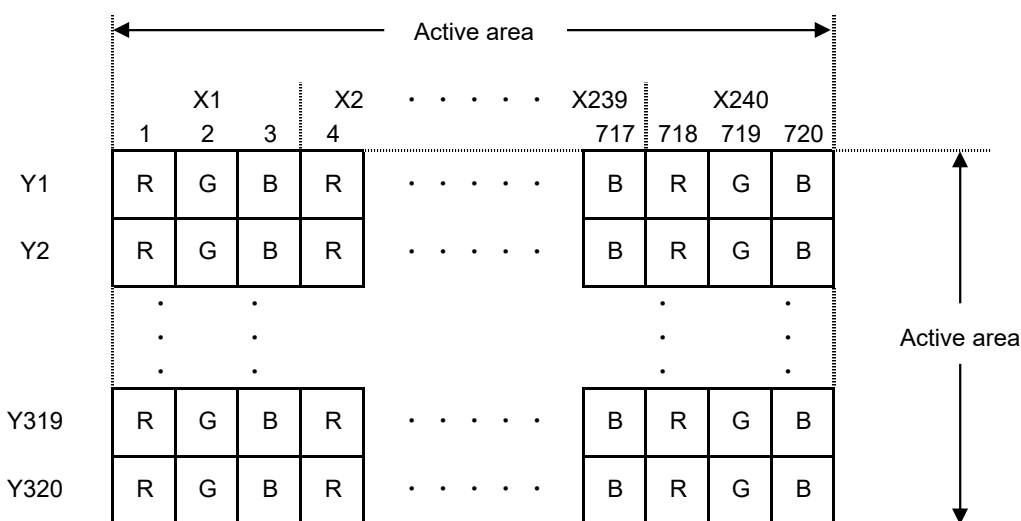

Dot arrangement (FPC cable placed right side)

3. Dimensions and Shape

3.1 Dimensions

Items	Specifications	Unit	Remarks
Outline dimensions	38.64[H] × 53.72[V] × 2.35[D]	mm	Exclude FPC cable and parts on FPC.
Active area	33.84[H] × 45.12[V]	mm	Diagonal: 2.22inch
Number of dots	240 × RGB [H] × 320[V]	dot	
Dot pitch	47[H] × 141[V]	um	
Surface hardness of the polarizer	3	H	Load:2.0N
Weight	11	g	Include FPC cable

<Features of Blanview>

- Backlight power consumption required to assure visibility. (equivalent to 3.5"QVGA)

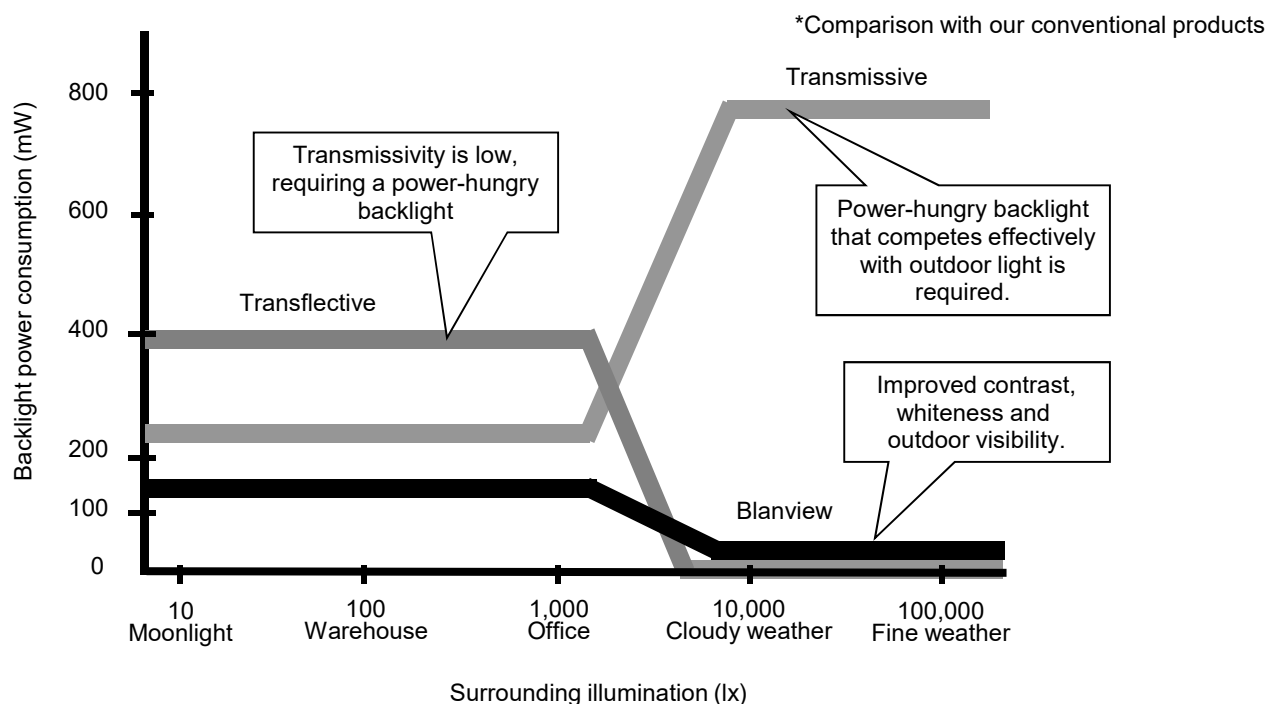

- Contrast characteristics under 100,000lx. (same condition as direct sunlight.)

With better contrast (higher contrast ratio), Blanview TFT-LCD has the best outdoor readability in three different types of TFT-LCD.

Below chart shows contrast value against panel surface brightness. (Horizontal: Panel surface brightness/ Vertical: Contrast value) LCD panel has enough outdoor readability above our Standard line. (TOPPAN PRINTING criteria)

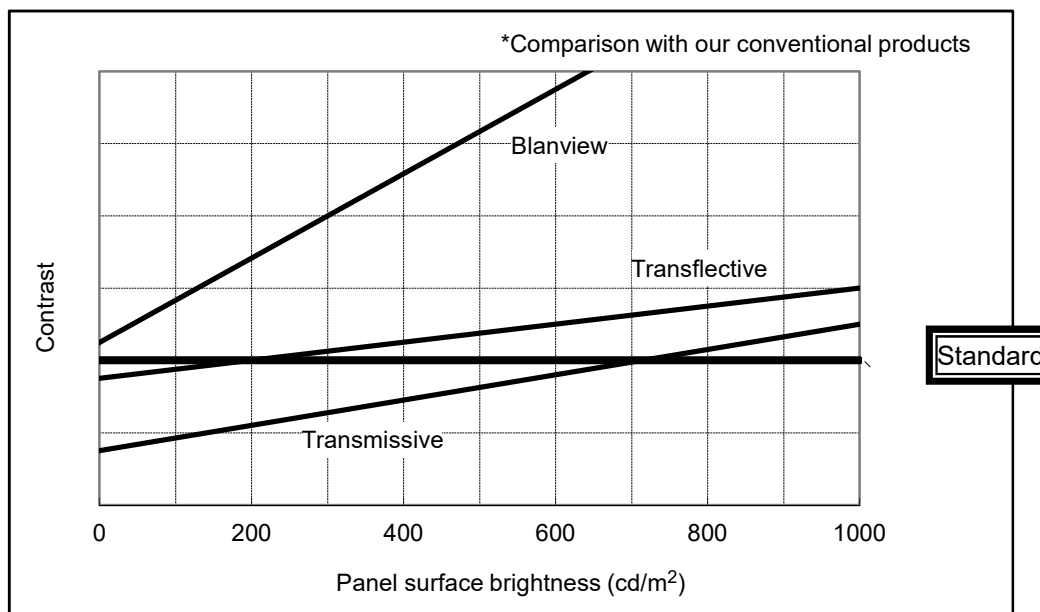

3.2 Outward Form

EC No.	REV. No.	REVISE	DATE (Y:M:D)	APPROVED	CHECKED	PREPARED
			:			

(7/37)
20TLM009
Issue:Feb.13,2020

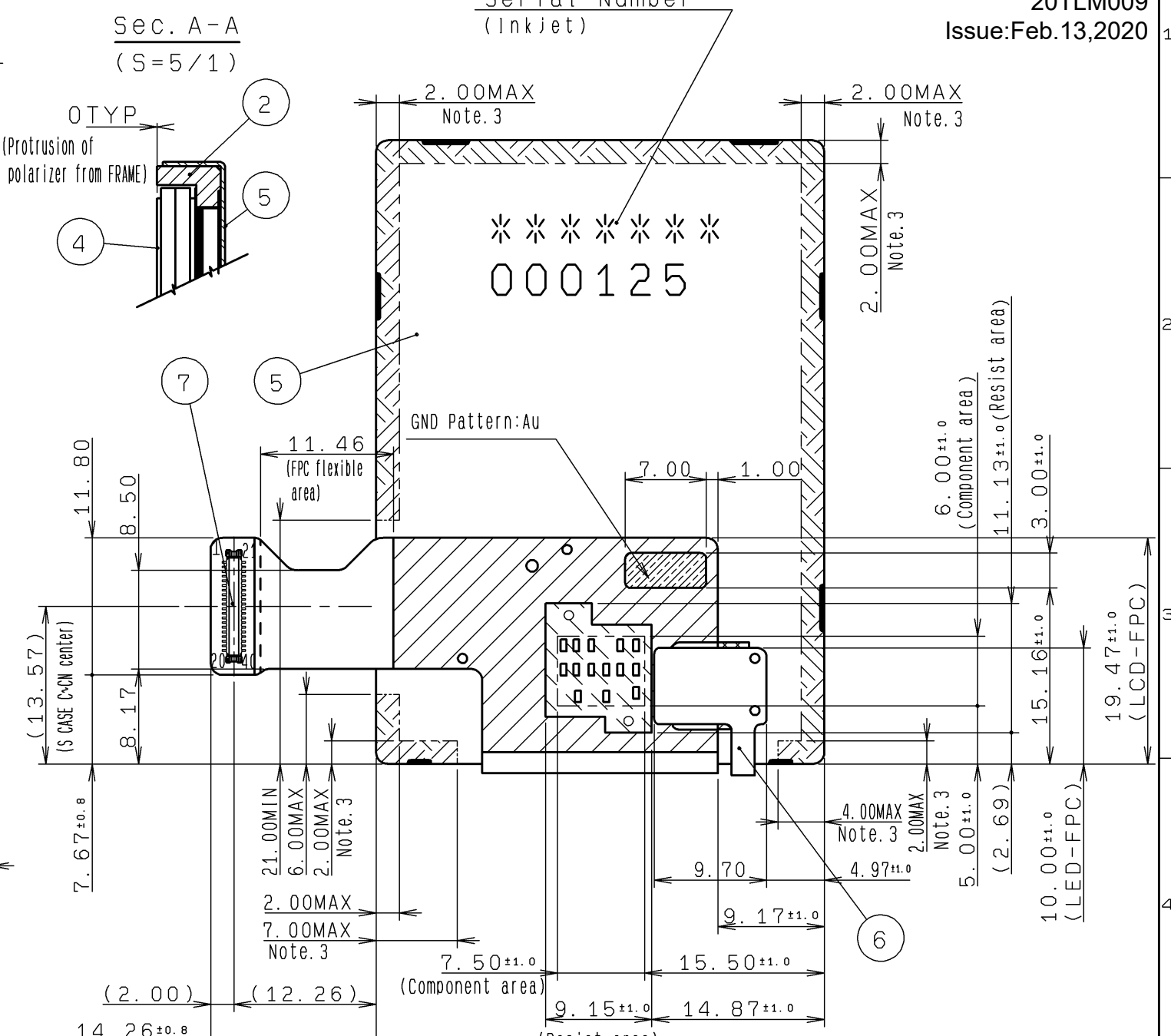
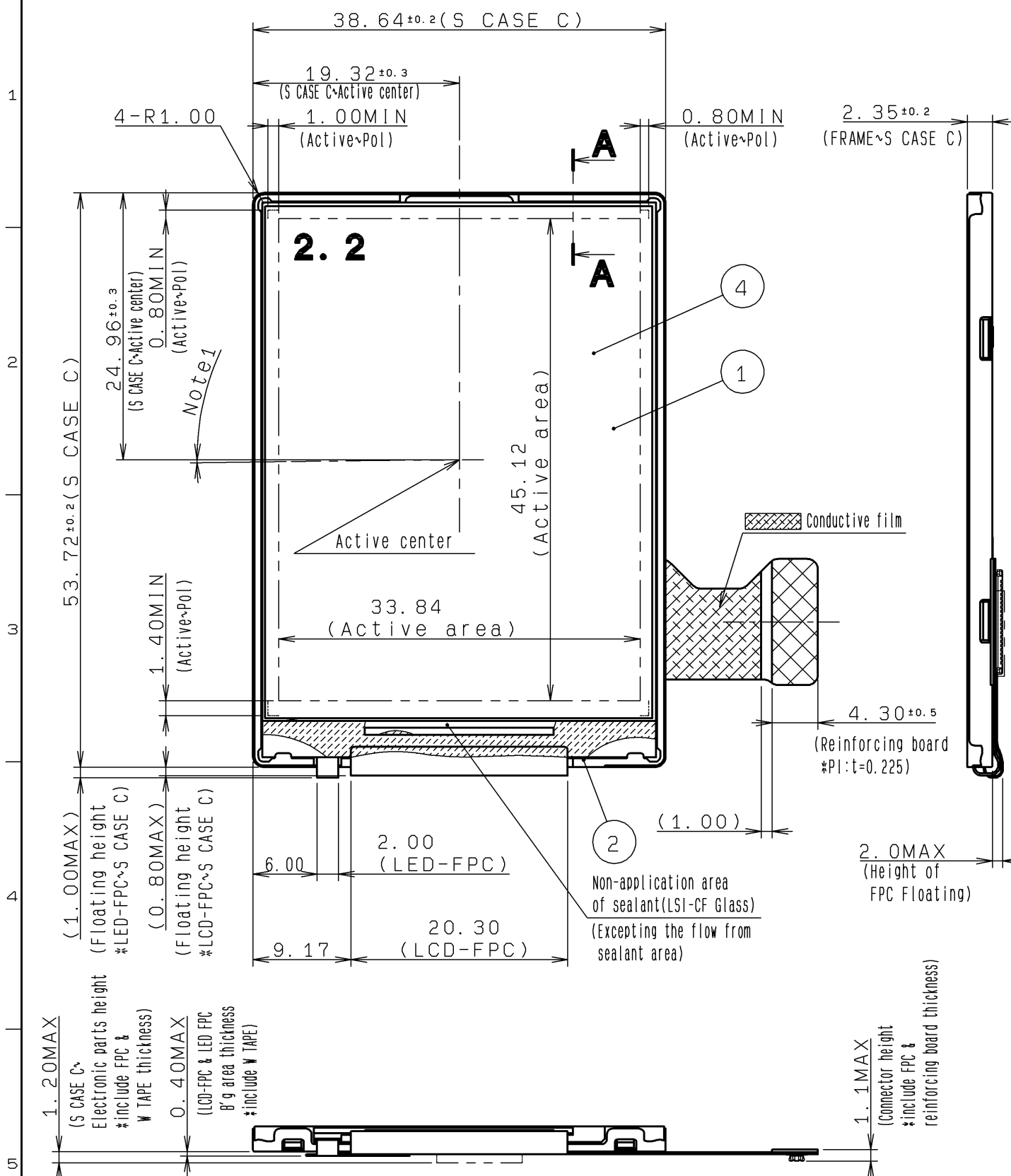

- Note 1. Angular deviation of LCD cell from the TFT-LCD monitor's reference axis shall be less than $[\pm 40']$.
- Note 2. Protective film is affixed on front surface of the screen. Location tolerance of the protective film shall be ± 1.5 mm to the polarizing film.
- Note 3. In case TFT-LCD monitor is fixed to the case of your product, it's recommended that monitor is fixed in to area.

CONNECTOR	7	AXE640124/Panasonic	User side:AXE540127/Panasonic
LED-FPC	6		
S CASE C	5		SUS (t=0.15)
POLARIZER	4		with protection sheet
LCD-FPC	3		
FRAME	2	PC	
TFT-LCD	1		Glass substrate thickness=0.5t±0.5t
PART NAME	ITEM	PART CODE	MODEL NUMBER

APPROVED 尾木	GENERAL TOLERANCE ± 0.5	SCALE 2/1	UNIT mm
CHECKED 加藤	ISSUE (Y:M:D) 20:01:27	MODEL CCM22H2P69U**	TOPPAN TOPPAN PRINTING CO., LTD. DO NOT DUPLICATE, CONFIDENTIAL AND PROPRIETARY
CHECKED	NAME		
DESIGN 前田創	OUTLINE-D2P69		
DRAW 前田創			
DRAWING No. RJD530971D301			REV. / SHEET / DIV. / ASS'Y

3.3 Serial № print (S-print)

1) Display Items

S-print indicates the least significant digit of manufacture year (1digit), manufacture month with below alphabet (1letter), model code (5characters), serial number (6digits).

* Contents of Display

*	*	*****	*****
-	-	-	-
a	b	c	d

Contents of display				
a	The least significant digit of manufacture year			
b	Manufacture month	Jan-A Feb-B Mar-C Apr-D	May-E Jun-F Jul-G Aug-H	Sep-I Oct-J Nov-K Dec-L
c	Model code	22CZC (Made in Japan) 22DAC (Made in Malaysia)		
d	Serial number			

* Example of indication of Serial № print (S-print)

•Made in Japan

0C22CZC000125

means "manufactured in March 2020, 2.2" CZ type, C specifications, serial number 000125"

•Made in Malaysia

0C22DAC000125

means "manufactured in March 2020, 2.2" DA type, C specifications, serial number 000125"

2) Location of Serial № print (S-print)

Refer to 3.2 "Outward Form".

3)Others

Please note that it is likely to disappear with an organic solvent about the Serial print.

4. Pin Assignment

No.	Symbol	Details	Remark	IO
1	FMARK	Frame Synchronizing Signal Output for LCD		O
2	LED+	LED anode		P
3	LED-	LED cathode		P
4	VCI	Power Supply for logic regulator		P
5	GND	Ground		P
6	NC	Non connection		-
7	IM0	Interface select signal		I
8	/CS	Chip select signal	L: Selected , H: Not selected	I
9	/WR	Write Signal		I
10	GND	Ground		P
11	DB1	Data Input & Output		IO
12	DB3	Data Input & Output		IO
13	DB5	Data Input & Output		IO
14	DB6	Data Input & Output		IO
15	DB8	Data Input & Output		IO
16	DB10	Data Input & Output		IO
17	GND	Ground		P
18	DB13	Data Input & Output		IO
19	DB15	Data Input & Output		IO
20	DB17	Data Input & Output		IO
21	GND	Ground		P
22	LED+	LED anode		P
23	LED-	LED cathode		P
24	IOVCC	Power Supply for interface Circuit		P
25	NC	Non connection		-
26	IM3	Interface select signal		I
27	/RESET	Reset signal	L:Initialize	I
28	RS	Select the register	L: Index/status registers , H: Data	I
29	/RD	Read Signal		I
30	DB0	Data Input & Output		IO
31	DB2	Data Input & Output		IO
32	DB4	Data Input & Output		IO
33	GND	Ground		P
34	DB7	Data Input & Output		IO
35	DB9	Data Input & Output		IO
36	DB11	Data Input & Output		IO
37	DB12	Data Input & Output		IO
38	DB14	Data Input & Output		IO
39	DB16	Data Input & Output		IO
40	GND	Ground		P

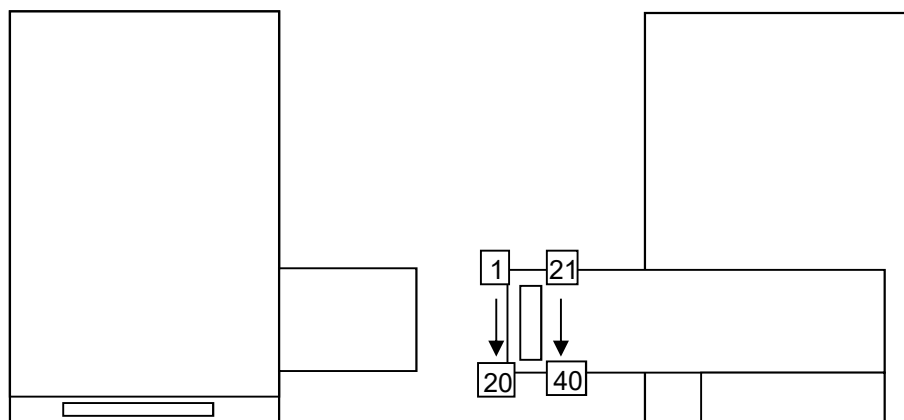

5. Block Diagram

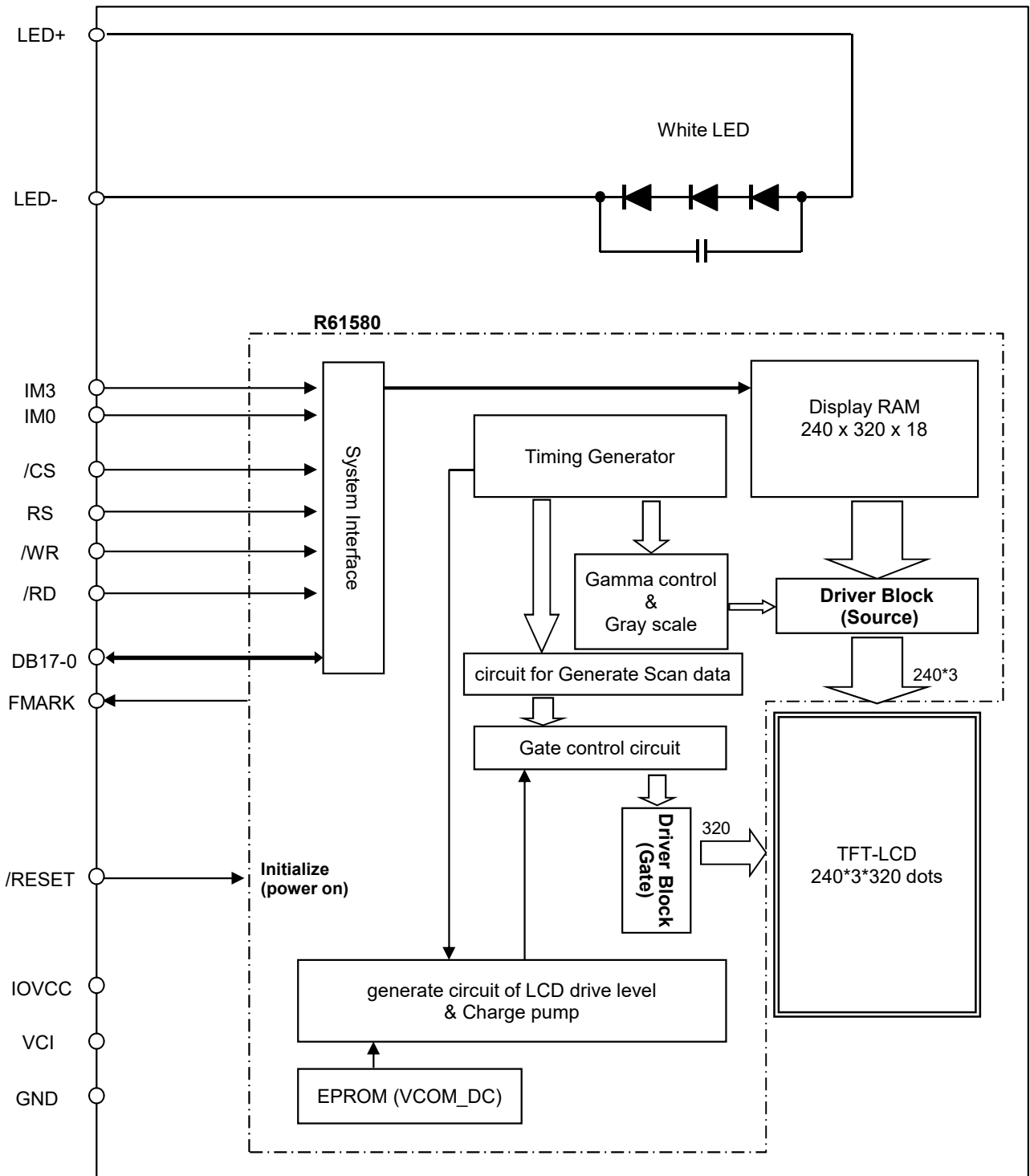

6. Absolute Maximum Rating

GND=0V

Item	Symbol	Condition	Rating		Unit	Applicable terminal
			MIN	MAX		
Supply voltage	VCI	Ta = 25 °C	-0.3	3.3	V	VCI
Logic interface voltage	IOVCC		-0.3	4.6	V	IOVCC
Input voltage for logic	VI		-0.3	VCCIO+0.3	V	/CS, RS, /WR, /RD, /RESET, DB17-0
LED Forward current	IL	Ta = 25 °C	--	35	mA	LED+ - LED-
		Ta = 70 °C	--	15	mA	
Storage temperature range	Tstg		-30	80	°C	
Storage humidity range	Hstg	Non condensing in an environmental moisture at or less than 40 °C 90%RH.				

Note: Do not exceed Allowable Forward Current shown on the chart below.

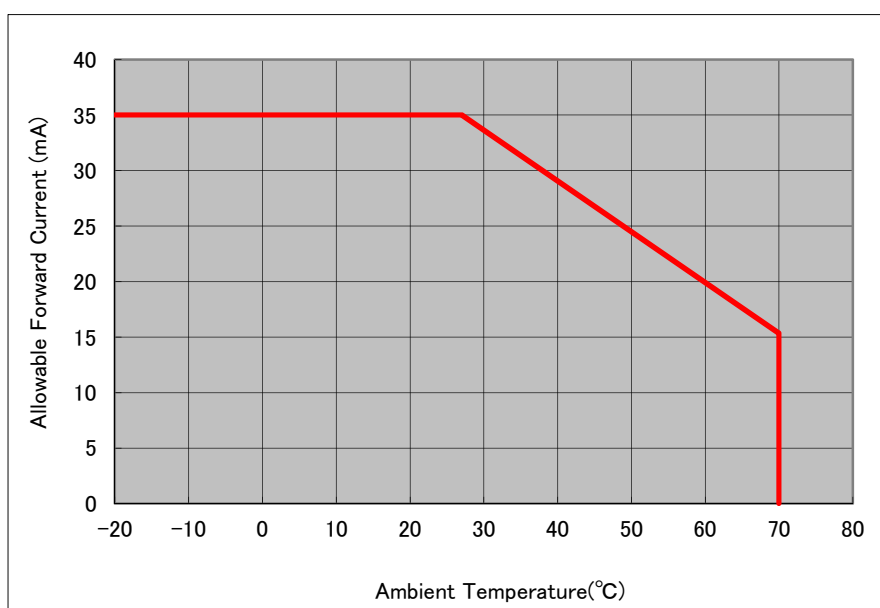

7. Recommended Operating Conditions

GND=0V

Item	Symbol	Condition	Rating			Unit	Applicable terminal
			MIN	TYP	MAX		
Supply voltage	VCI	Ta=-20~70°C	2.7	2.8	2.9	V	VCI
Logic interface voltage	IOVCC		1.7	2.8	2.9	V	IOVCC
Input voltage for logic	VI		0	—	IOVCC	V	/CS, RS, /WR, /RD, /RESET, DB17-0
LED Forward current	IL	Ta=-20~70°C	-	5.0	20.0	mA	LED+ - LED-
LED Forward voltage	VL	Ta=25°C IL=5.0mA	7.62	8.07	8.40	V	
Operational temperature range	Top	Note1	-20	25	70	°C	Panel surface temperature
Operating humidity range	Hop	Ta≤30°C	20	—	80	%	Non condensing in an environmental moisture at or less than 30 °C 80%RH.
		Ta>30°C					

Note1: This monitor is operable in this temperature range. With regard to optical characteristics, refer to Item 13."CHARACTERISTICS".

8. Characteristics

8.1 DC Characteristics

(Unless otherwise noted, Ta=25 °C,VCI=IOVCC=2.8V)

Item	Symbol	Condition	Rating			Unit	Applicable terminal
			MIN	TYP	MAX		
Input Signal Voltage 1	VIH 1	IOVCC=1.7-2.9V	0.8×IOVCC	--	IOVCC	V	/CS, RS, /WR, /RD, DB17-0
	VIL 1		0	--	0.2×IOVCC	V	
Input Signal Voltage 2	VIH 2	IOVCC=1.7-2.9V	0.9×IOVCC	--	IOVCC	V	/RESET
	VIL 2		0	--	0.1×IOVCC	V	
Output Signal Voltage	VOH	IOH = -0.1 mA	0.8×IOVCC	--	IOVCC	V	DB17-0,FMARK
	VOL	IOL = 0.1 mA	0	--	0.2×IOVCC	V	
Operating Current	ICI	Color bar display	--	9.0	18.0	mA	VCI + IOVCC
Stand-by Current	ICIS	Other input with constant voltage	--	--	2.0	uA	VCI + IOVCC

8.2 AC Characteristics

8.2.1 System I/F timing Characteristics

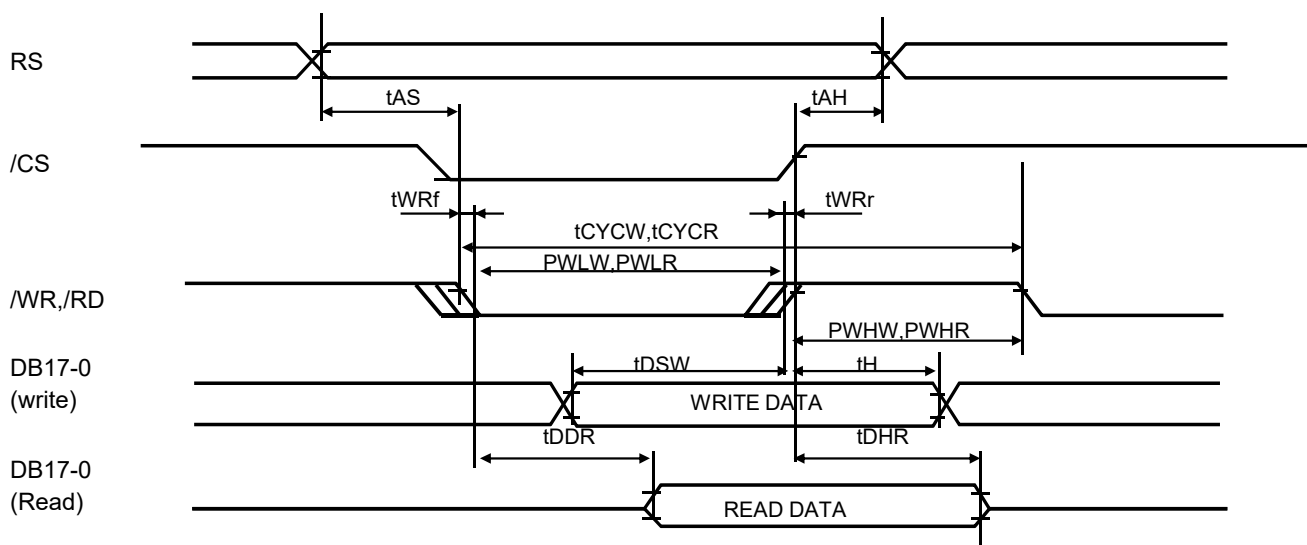

Note : PVLW and PVLr are determined by the overlap period of low /CS and low /WR or low /CS and low /RD.

VCI=2.7~2.9[V], IOVCC=1.7~2.9[V], Ta=-20~70°C

Item	Symbol	Condition	Rating		Unit
			MIN	MAX	
Bus cycle time	Write	t_{CYCW}	75	-	ns
	Read	t_{CYCR}	450	-	ns
/WR Low pulse width	Write	PVLW	40	-	ns
/WR High pulse width	Write	PWHW	25	-	ns
/RD Low pulse width	Read	PVLr	170	-	ns
/RD High pulse width	Read	PWHr	250	-	ns
Write / Read rise / fall time		t_{WRr} , t_{WRf}	-	25	ns
Setup time	RS to /CS,/WR	t_{AS}	0		ns
	RS to /CS,/RD		10		ns
Address hold time		t_{AH}	2		ns
Write data setup time		t_{DSW}	25		ns
Write data hold time		t_H	10		ns
Read data delay time		t_{DDR}	-	150	ns
Read data hold time		t_{DHR}	5	-	ns

8.2.2 RESET Timing

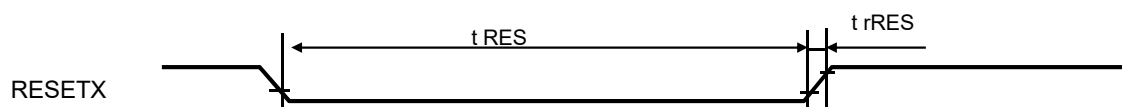
 $V_{CI}=2.7\sim 2.9[V]$, $I_{OVCC}=1.7\sim 2.9[V]$, $T_a=-20\sim 70^{\circ}C$

Item	Symbol	Condition	Rating			Unit
			MIN	TYP	MAX	
Reset low pulse width	t RES		1	—	—	ms
Reset rise time	t rRES		—	—	10	us

9. Interface

9.1 Interface Mode

Relation between GRAM data and Display data

The following figure illustrates the relationship between data on GRAM and display data through each interface.

<18bit interface> IM3 =1 , IM0 =0

Input pins	DB17	DB16	DB15	DB14	DB13	DB12	DB11	DB10	DB9	DB8	DB7	DB6	DB5	DB4	DB3	DB2	DB1	DB0
Instruction	IB15	IB14	IB13	IB12	IB11	IB10	IB9	IB8	*	IB7	IB6	IB5	IB4	IB3	IB2	IB1	IB0	*
data	R5	R4	R3	R2	R1	R0	G5	G4	G3	G2	G1	G0	B5	B4	B3	B2	B1	B0

262,144 colors

<16bit interface> IM3 =0 , IM0 =0

Input pins	DB17	DB16	DB15	DB14	DB13	DB12	DB11	DB10	DB9	DB8	DB7	DB6	DB5	DB4	DB3	DB2	DB1	DB0
Instruction	IB15	IB14	IB13	IB12	IB11	IB10	IB9	IB8	Lo	IB7	IB6	IB5	IB4	IB3	IB2	IB1	IB0	Lo
single transfer mode: TRIREG =0																		
data	R5/R0	R4	R3	R2	R1	G5	G4	G3	Lo	G2	G1	G0	B5/B0	B4	B3	B2	B1	Lo

65,536 colors

2-transfer mode: TRIREG =1, DFM =0

data	1st	R5	R4	R3	R2	R1	R0	G5	G4	Lo	G3	G2	G1	G0	B5	B4	B3	B2	Lo
	2nd	B1	B0	*	*	*	*	*	*	Lo	*	*	*	*	*	*	*	*	Lo

262,144 colors

2-transfer mode: TRIREG =1, DFM =1

data	1st	*	*	*	*	*	*	*	*	Lo	*	*	*	*	*	*	R5	R4	Lo
	2nd	R3	R2	R1	R0	G5	G4	G3	G2	Lo	G1	G0	B5	B4	B3	B2	B1	B0	Lo

262,144 colors

<9bit interface> IM3 =1 , IM0 =1

Input pins	DB17	DB16	DB15	DB14	DB13	DB12	DB11	DB10	DB9	DB8	DB7	DB6	DB5	DB4	DB3	DB2	DB1	DB0	
Instruction	1st	IB15	IB14	IB13	IB12	IB11	IB10	IB9	IB8	*	Lo	Lo	Lo	Lo	Lo	Lo	Lo	Lo	Lo
	2nd	IB7	IB6	IB5	IB4	IB3	IB2	IB1	IB0	*	Lo	Lo	Lo	Lo	Lo	Lo	Lo	Lo	Lo
data	1st	R5	R4	R3	R2	R1	R0	G5	G4	G3	Lo	Lo	Lo	Lo	Lo	Lo	Lo	Lo	Lo
	2nd	G2	G1	G0	B5	B4	B3	B2	B1	B0	Lo	Lo	Lo	Lo	Lo	Lo	Lo	Lo	Lo

262,144 colors

<8bit interface> IM3 =0 , IM0 =1

Input pins	DB17	DB16	DB15	DB14	DB13	DB12	DB11	DB10	DB9	DB8	DB7	DB6	DB5	DB4	DB3	DB2	DB1	DB0	
Instruction	1st	IB15	IB14	IB13	IB12	IB11	IB10	IB9	IB8	Lo	Lo	Lo	Lo	Lo	Lo	Lo	Lo	Lo	Lo
	2nd	IB7	IB6	IB5	IB4	IB3	IB2	IB1	IB0	Lo	Lo	Lo	Lo	Lo	Lo	Lo	Lo	Lo	Lo
2-transfer mode: TRIREG =0																			
data	1st	R5/R0	R4	R3	R2	R1	G5	G4	G3	Lo	Lo	Lo	Lo	Lo	Lo	Lo	Lo	Lo	Lo
	2nd	G2	G1	G0	B5/B0	B4	B3	B2	B1	Lo	Lo	Lo	Lo	Lo	Lo	Lo	Lo	Lo	Lo

65,536 colors

3-transfer mode: TRIREG =1, DFM =0

data	1st	*	*	*	*	*	*	R5	R4	Lo	Lo	Lo	Lo	Lo	Lo	Lo	Lo	Lo	Lo
	2nd	R3	R2	R1	R0	G5	G4	G3	G2	Lo	Lo	Lo	Lo	Lo	Lo	Lo	Lo	Lo	Lo
	3rd	G1	G0	B5	B4	B3	B2	B1	B0	Lo	Lo	Lo	Lo	Lo	Lo	Lo	Lo	Lo	Lo

262,144 colors

3-transfer mode: TRIREG =1, DFM =1

data	1st	R5	R4	R3	R2	R1	R0	*	*	Lo	Lo	Lo	Lo	Lo	Lo	Lo	Lo	Lo	Lo
	2nd	G5	G4	G3	G2	G1	G0	*	*	Lo	Lo	Lo	Lo	Lo	Lo	Lo	Lo	Lo	Lo
	3rd	B5	B4	B3	B2	B1	B0	*	*	Lo	Lo	Lo	Lo	Lo	Lo	Lo	Lo	Lo	Lo

262,144 colors

9.2 System interface timing

Send registers and data in accordance with the following transfer format.

a) Write to register

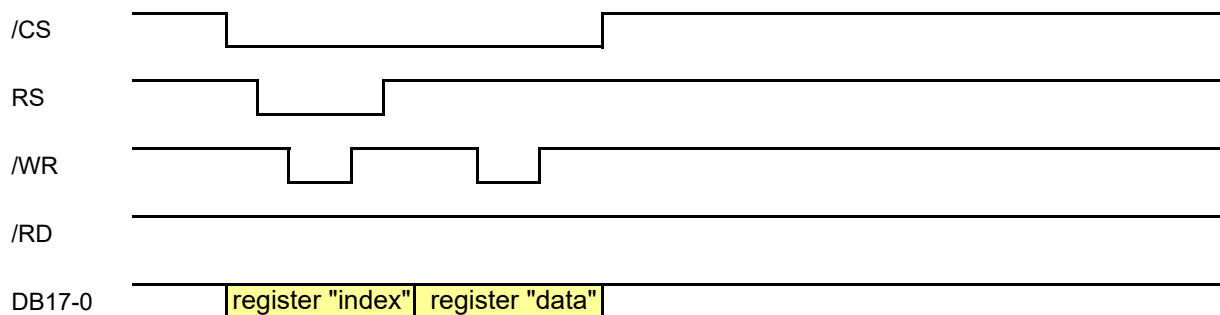

b) Write to GRAM

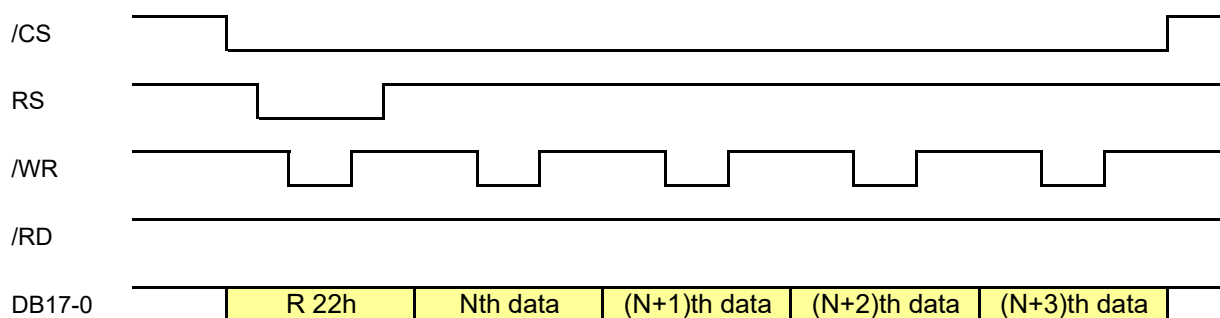

c) Read from register

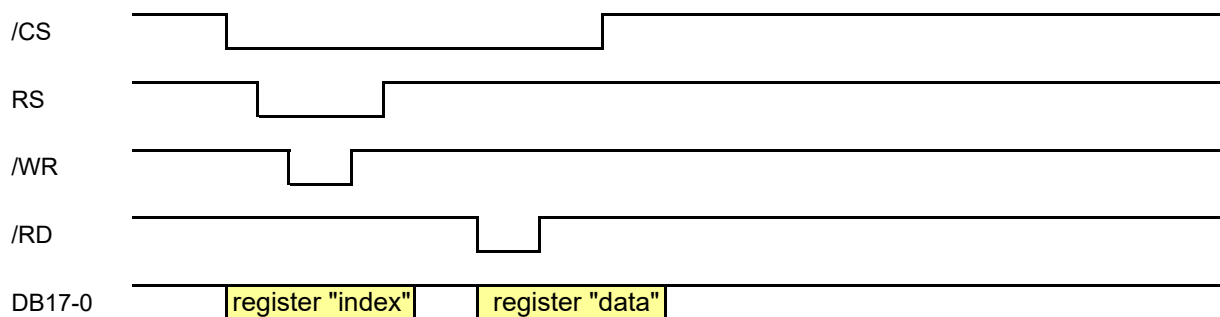

d) Read from GRAM

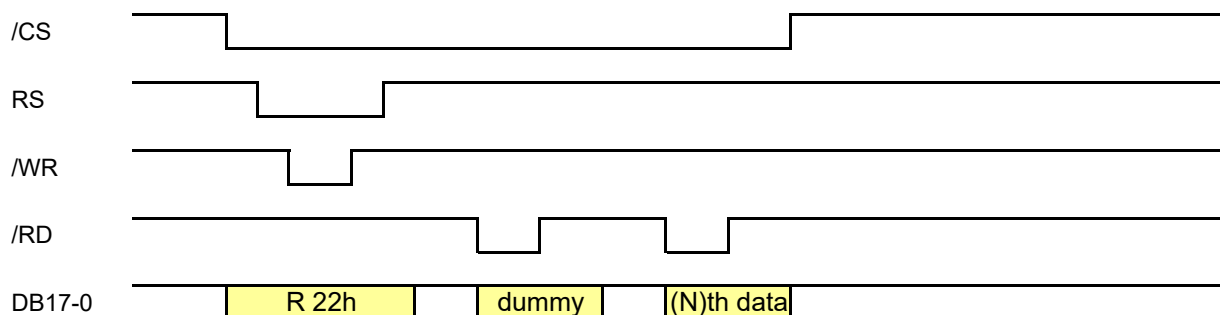

* If you want to continue reading, please set the new address because it does not address the auto-increment.

10. Register List

IR	Registers Name	IB15	IB14	IB13	IB12	IB11	IB10	IB9	IB8	IB7	IB6	IB5	IB4	IB3	IB2	IB1	IB0
	Index Register (RS=0)	*	*	*	*	*	*	*	*	IR7	IR6	IR5	IR4	IR3	IR2	IR1	IR0
R00h	Driver Code Read	Read out only															
	Initial	1580h	0	0	0	1	0	1	0	1	1	0	0	0	0	0	0
	recommend		-	-	-	-	-	-	-	-	-	-	-	-	-	-	-
R01h	Driver Output Control 1	0	0	0	0	0	SM	0	SS	0	0	0	0	0	0	0	0
	Initial	0000h	0	0	0	0	0	0	0	0	0	0	0	0	0	0	0
	recommend	0500h	0	0	0	0	0	1	0	1	0	0	0	0	0	0	0
R02h	LCD Driving Control	0	0	0	0	0	0	BC0	0	0	0	0	0	0	0	0	NW0
	Initial	0000h	0	0	0	0	0	0	0	0	0	0	0	0	0	0	0
	recommend	0200h	0	0	0	0	0	0	1	0	0	0	0	0	0	0	0
R03h	Entry Mode	TRI REG	DFM	0	BGR	0	0	0	0	ORG	0	I/D[1:0]	AM	0	0	0	0
	Initial	0030h	0	0	0	0	0	0	0	0	0	1	1	0	0	0	0
	recommend	1030h	0	0	0	1	0	0	0	0	0	1	1	0	0	0	0
R07h	Display Control 1	0	0	0	PTD E	0	0	0	BAS EE	0	0	0	0	COL	0	0	0
	Initial	0000h	0	0	0	0	0	0	0	0	0	0	0	0	0	0	0
	recommend	0100h	0	0	0	0	0	0	1	0	0	0	0	0	0	0	0
R08h	Display Control 2	FP[7:0]							BP[7:0]								
	Initial	0808h	0	0	0	0	1	0	0	0	0	0	0	1	0	0	0
	recommend	0503h	0	0	0	0	0	1	0	1	0	0	0	0	0	1	1
R09h	Display Control 3	0	0	0	0	0	PTS[2:0]	0	0	0	0	PTG	0	ISC[3:0]	0	0	0
	Initial	0001h	0	0	0	0	0	0	0	0	0	0	0	0	0	0	1
	recommend	0001h	0	0	0	0	0	0	0	0	0	0	0	0	0	0	1
R0Ah	Display Control 4	0	0	0	0	0	0	0	0	0	0	0	0	FMA RKO	FM[2:0]	0	0
	Initial	0000h	0	0	0	0	0	0	0	0	0	0	0	0	0	0	0
	recommend	0008h	0	0	0	0	0	0	0	0	0	0	0	1	0	0	0
R0Ch	RGB I/F Control 1	0	ENC[2:0]	0	0	0	0	RM	0	0	0	DM[1:0]	0	0	RIM[1:0]	0	0
	Initial	0000h	0	0	0	0	0	0	0	0	0	0	0	0	0	0	0
	recommend	0000h	0	0	0	0	0	0	0	0	0	0	0	0	0	0	0
R0Dh	FMARK Position	0	0	0	0	0	0	0	0	FMP[8:0]							
	Initial	0000h	0	0	0	0	0	0	0	0	0	0	0	0	0	0	0
	recommend	0000h	0	0	0	0	0	0	0	0	0	0	0	0	0	0	0
R0Eh	VCOML voltage Control	0	0	0	0	0	0	0	0	0	0	VEM[1:0]	0	0	0	0	0
	Initial	0030h	0	0	0	0	0	0	0	0	0	1	1	0	0	0	0
	recommend	0030h	0	0	0	0	0	0	0	0	0	1	1	0	0	0	0
R0Fh	RGB I/F Control 2	0	0	0	0	0	0	0	0	0	0	VSP L	HSP L	0	EPL	DPL	0
	Initial	0000h	0	0	0	0	0	0	0	0	0	0	0	0	0	0	0
	recommend	0000h	0	0	0	0	0	0	0	0	0	0	0	0	0	0	0
R10h	Power Control 1	0	0	0	0	0	BT[2:0]	0	0	0	0	AP[1:0]	0	DST B	0	0	0
	Initial	0530h	0	0	0	0	0	1	0	1	0	0	1	1	0	0	0
	recommend	0310h	0	0	0	0	0	0	1	1	0	0	0	1	0	0	0
R11h	Power Control 2	0	0	0	0	0	DC1[2:0]	0	0	0	0	DC0[2:0]	0	VC[2:0]	0	0	0
	Initial	0237h	0	0	0	0	0	1	0	0	0	1	1	0	1	1	1
	recommend	0231h	0	0	0	0	0	0	1	0	0	0	1	0	0	0	1
R12h	Power Control 3	0	0	0	VRH 0	0	0	0	VCM R	1	0	PSO N	PON	VRH[4:1]	0	0	0
	Initial	018Fh	0	0	0	0	0	0	1	1	0	0	0	1	1	1	1
	recommend	01BCh	0	0	0	0	0	0	1	1	0	1	1	1	1	0	0
R13h	Power Control 4	0	0	0	VDV[4:0]					0	0	0	0	0	0	0	0
	Initial	0000h	0	0	0	0	0	0	0	0	0	0	0	0	0	0	0
	recommend	1400h	0	0	0	1	0	1	0	0	0	0	0	0	0	0	0

IR	Registers Name	IB15	IB14	IB13	IB12	IB11	IB10	IB9	IB8	IB7	IB6	IB5	IB4	IB3	IB2	IB1	IB0	
R20h	Horizontal RAM Address Set	0	0	0	0	0	0	0	0	AD[7:0]								
	Initial	0000h	0	0	0	0	0	0	0	0	0	0	0	0	0	0	0	0
	recommend	0000h	0	0	0	0	0	0	0	0	0	0	0	0	0	0	0	0
R21h	Vertical RAM Address Set	0	0	0	0	0	0	0	AD[16:8]									
	Initial	0000h	0	0	0	0	0	0	0	0	0	0	0	0	0	0	0	0
	recommend	0000h	0	0	0	0	0	0	0	0	0	0	0	0	0	0	0	0
R22h	Write/Read Data	RAM write/read data																
	Initial	----																
	recommend	----																
R29h	VCOMH voltage Control	0	0	0	0	0	0	0	0	0	VCM1[6:0]							
	Initial	00FFh	0	0	0	0	0	0	0	0	1	1	1	1	1	1	1	1
	recommend	0065h	0	0	0	0	0	0	0	0	0	1	1	0	0	1	0	1
R30h	Gamma Control 1	0	0	0	PR0P01[4:0]				0	0	0	PR0P00[4:0]						
	Initial	0000h	0	0	0	0	0	0	0	0	0	0	0	0	0	0	0	0
	recommend	0500h	0	0	0	0	0	1	0	1	0	0	0	0	0	0	0	0
R31h	Gamma Control 2	PR0P04[3:0]			PR0P03[3:0]				0	0	0	PR0P02[4:0]						
	Initial	0000h	0	0	0	0	0	0	0	0	0	0	0	0	0	0	0	0
	recommend	3711h	0	0	1	1	0	1	1	1	0	0	0	1	0	0	0	1
R32h	Gamma Control 3	0	0	0	PR0P06[4:0]				0	0	0	0	PR0P05[3:0]					
	Initial	0000h	0	0	0	0	0	0	0	0	0	0	0	0	0	0	0	0
	recommend	0605h	0	0	0	0	0	0	1	1	0	0	0	0	0	1	0	1
R33h	Gamma Control 4	0	0	0	PR0P08[4:0]				0	0	0	PR0P07[4:0]						
	Initial	0000h	0	0	0	0	0	0	0	0	0	0	0	0	0	0	0	0
	recommend	120Dh	0	0	0	1	0	0	1	0	0	0	0	1	1	0	0	1
R34h	Gamma Control 5	0	0	PIR0P3 [1:0]		0	0	PIR0P2 [1:0]		0	0	PIR0P1 [1:0]		0	0	PIR0P0 [1:0]		
	Initial	0000h	0	0	0	0	0	0	0	0	0	0	0	0	0	0	0	
	recommend	1202h	0	0	0	1	0	0	1	0	0	0	0	0	0	1	0	
R35h	Gamma Control 6	0	0	0	PR0N01[4:0]				0	0	0	PR0N00[4:0]						
	Initial	0000h	0	0	0	0	0	0	0	0	0	0	0	0	0	0	0	0
	recommend	0D0Ah	0	0	0	0	1	1	0	1	0	0	0	0	1	0	1	0
R36h	Gamma Control 7	PR0N04[3:0]			PR0N03[3:0]				0	0	0	PR0N02[4:0]						
	Initial	0000h	0	0	0	0	0	0	0	0	0	0	0	0	0	0	0	0
	recommend	3506h	0	0	0	1	1	0	1	0	0	0	0	0	0	1	1	0
R37h	Gamma Control 8	0	0	0	PR0N06[4:0]				0	0	0	0	PR0N05[3:0]					
	Initial	0000h	0	0	0	0	0	0	0	0	0	0	0	0	0	0	0	0
	recommend	1107h	0	0	0	1	0	0	0	1	0	0	0	0	0	1	1	1
R38h	Gamma Control 9	0	0	0	PR0N08[4:0]				0	0	0	PR0N07[4:0]						
	Initial	0000h	0	0	0	0	0	0	0	0	0	0	0	0	0	0	0	0
	recommend	0005h	0	0	0	0	0	0	0	0	0	0	0	0	0	1	0	1
R39h	Gamma Control 10	0	0	PIR0N3 [1:0]		0	0	PIR0N2 [1:0]		0	0	PIR0N1 [1:0]		0	0	PIR0N0 [1:0]		
	Initial	0000h	0	0	0	0	0	0	0	0	0	0	0	0	0	0	0	
	recommend	0212h	0	0	0	0	0	0	1	0	0	0	0	1	0	0	1	0
R50h	Window Horizontal RAM Start Address	0	0	0	0	0	0	0	0	HSA[7:0]								
	Initial	0000h	0	0	0	0	0	0	0	0	0	0	0	0	0	0	0	0
	recommend	0000h	0	0	0	0	0	0	0	0	0	0	0	0	0	0	0	0
R51h	Window Horizontal RAM End Address	0	0	0	0	0	0	0	0	HEA[7:0]								
	Initial	00EFh	0	0	0	0	0	0	0	1	1	1	0	1	1	1	1	1
	recommend	00EFh	0	0	0	0	0	0	0	1	1	1	0	1	1	1	1	1
R52h	Window Vertical RAM Start Address	0	0	0	0	0	0	0	VSA[8:0]									
	Initial	0000h	0	0	0	0	0	0	0	0	0	0	0	0	0	0	0	0
	recommend	0000h	0	0	0	0	0	0	0	0	0	0	0	0	0	0	0	0
R53h	Window Vertical RAM End Address	0	0	0	0	0	0	0	VEA[8:0]									
	Initial	013Fh	0	0	0	0	0	0	1	0	0	1	1	1	1	1	1	1
	recommend	013Fh	0	0	0	0	0	0	1	0	0	1	1	1	1	1	1	1

IR	Registers Name	IB15	IB14	IB13	IB12	IB11	IB10	IB9	IB8	IB7	IB6	IB5	IB4	IB3	IB2	IB1	IB0	
R60h	Driver Output Control 2	GS	0	NL[5:0]					0	0	SCN[5:0]							
	Initial	2700h	0	0	1	0	0	1	1	1	0	0	0	0	0	0	0	0
	recommend	A700h	1	0	1	0	0	1	1	1	0	0	0	0	0	0	0	0
R61A	Base Image Display Control	0	0	0	0	0	0	0	0	0	0	0	0	0	NDL	VLE	REV	
	Initial	0000h	0	0	0	0	0	0	0	0	0	0	0	0	0	0	0	
	recommend	0000h	0	0	0	0	0	0	0	0	0	0	0	0	0	0	0	
R6Ah	Vertical Scroll Control	0	0	0	0	0	0	0	VL[8:0]									
	Initial	0000h	0	0	0	0	0	0	0	0	0	0	0	0	0	0	0	
	recommend	0000h	0	0	0	0	0	0	0	0	0	0	0	0	0	0	0	
R80h	Partial Image Display Position	0	0	0	0	0	0	0	PTDP[8:0]									
	Initial	0000h	0	0	0	0	0	0	0	0	0	0	0	0	0	0	0	
	recommend	0000h	0	0	0	0	0	0	0	0	0	0	0	0	0	0	0	
R81h	Partial Image Area (Start Line)	0	0	0	0	0	0	0	PTSA[8:0]									
	Initial	0000h	0	0	0	0	0	0	0	0	0	0	0	0	0	0	0	
	recommend	0000h	0	0	0	0	0	0	0	0	0	0	0	0	0	0	0	
R82h	Partial Image Area (End Line)	0	0	0	0	0	0	0	PTEA[8:0]									
	Initial	0000h	0	0	0	0	0	0	0	0	0	0	0	0	0	0	0	
	recommend	0000h	0	0	0	0	0	0	0	0	0	0	0	0	0	0	0	
R90h	Panel I/F Control 1	0	0	0	0	0	0	DIVI[1:0]		0	0	0	RTNI[4:0]					
	Initial	0111h	0	0	0	0	0	0	1	0	0	0	1	0	0	0	1	
	recommend	001Dh	0	0	0	0	0	0	0	0	0	0	1	1	1	0	1	
R91h	Panel I/F Control 1-1	0	0	0	0	0	0	0	0	0	0	0	SPCWI[3:0]					
	Initial	0001h	0	0	0	0	0	0	0	0	0	0	0	0	0	0	1	
	recommend	0003h	0	0	0	0	0	0	0	0	0	0	0	0	0	1	1	
R92h	Panel I/F Control 2	0	0	0	0	0	NOWI[2:0]		0	0	0	0	0	0	0	0	0	
	Initial	0100h	0	0	0	0	1	0	0	0	0	0	0	0	0	0	0	
	recommend	0100h	0	0	0	0	1	0	0	0	0	0	0	0	0	0	0	
R93h	Panel I/F Control 3	0	0	0	0	0	VEQWI[2:0]		0	0	0	0	0	MCPI[2:0]				
	Initial	0101h	0	0	0	0	0	0	1	0	0	0	0	0	0	0	1	
	recommend	0201h	0	0	0	0	0	1	0	0	0	0	0	0	0	0	1	
R94h	Panel I/F Control 4	0	0	0	0	0	0	0	0	0	0	0	0	SDTI[2:0]				
	Initial	0001h	0	0	0	0	0	0	0	0	0	0	0	0	0	0	1	
	recommend	0001h	0	0	0	0	0	0	0	0	0	0	0	0	0	0	1	
R95h	Panel I/F Control 5	0	0	0	0	0	0	DIVE[1:0]		0	0	RTNE[4:0]						
	Initial	001Fh	0	0	0	0	0	0	0	0	0	1	1	1	1	1		
	recommend	001Fh	0	0	0	0	0	0	0	0	0	1	1	1	1	1		
R96h	Panel I/F Control 5-1	0	0	0	0	0	0	0	0	0	0	0	SPCWE[3:0]					
	Initial	0001h	0	0	0	0	0	0	0	0	0	0	0	0	0	0	1	
	recommend	0001h	0	0	0	0	0	0	0	0	0	0	0	0	0	0	1	
R97h	Panel I/F Control 6	0	0	0	0	0	NOWE[2:0]		0	0	0	0	0	0	0	0	0	
	Initial	0100h	0	0	0	0	0	0	1	0	0	0	0	0	0	0	0	
	recommend	0100h	0	0	0	0	0	0	1	0	0	0	0	0	0	0	0	
R98h	Panel I/F Control 7	0	0	0	0	0	VEQWE[2:0]		0	0	0	0	0	MCPE[2:0]				
	Initial	0101h	0	0	0	0	0	0	1	0	0	0	0	0	0	0	1	
	recommend	0101h	0	0	0	0	0	0	1	0	0	0	0	0	0	0	1	
R99h	Panel I/F Control 8	0	0	0	0	0	0	0	0	0	0	0	SDTE[2:0]					
	Initial	0001h	0	0	0	0	0	0	0	0	0	0	0	0	0	0	1	
	recommend	0001h	0	0	0	0	0	0	0	0	0	0	0	0	0	0	1	
R9Ch	Panel I/F Control 9	0	0	0	0	0	0	0	0	0	PCDIVH[2:0]		0	PCDIVL[2:0]				
	Initial	0043h	0	0	0	0	0	0	0	0	1	0	0	0	0	1	1	
	recommend	0043h	0	0	0	0	0	0	0	0	1	0	0	0	0	1	1	
RA4h	NVM Calibration	0	0	0	0	0	0	0	0	0	0	0	0	0	0	0	CAL B	
	Initial	0000h	0	0	0	0	0	0	0	0	0	0	0	0	0	0	0	
	recommend	0001h	0	0	0	0	0	0	0	0	0	0	0	0	0	0	1	

11. Sequence

11.1 Power ON Sequence

(1/2)

No.		Function	Register	recommend	Remarks
1	Power ON	VCI,IOVCC ON			
2		/RESET=0			
3	Wait	1msec or more			
4		/RESET=1			
5	Wait	2msec or more			
6	data transfer synchronization	RS=0	-	0000 h	
		RS=0	-	0000 h	
		RS=0	-	0000 h	
		RS=0	-	0000 h	
7		NVM Calibration	RA4h	0001 h	
8	Wait	0.2msec or more			
9	Instruction user setting	Driver Output Control 2	R60h	A700 h	
		Display Control 2	R08h	0503 h	
		Gamma Control 1	R30h	0500 h	
		Gamma Control 2	R31h	3711 h	
		Gamma Control 3	R32h	0605 h	
		Gamma Control 4	R33h	120D h	
		Gamma Control 5	R34h	1202 h	
		Gamma Control 6	R35h	0D0A h	
		Gamma Control 7	R36h	3506 h	
		Gamma Control 8	R37h	1107 h	
		Gamma Control 9	R38h	0005 h	
		Gamma Control 10	R39h	0212 h	
		Panel I/F Control 1	R90h	001D h	
		Power Control 1	R10h	0310 h	
Power Control 2	R11h	0231 h			
Power Control 3	R13h	1400 h			
Power Control 4	R12h	01BC h			
10	Wait	wait 100 msec or more			
11	Other mode setting	Driver Output Control 1	R01h	0500 h	
		LCD Driving Control	R02h	0200 h	
		Entry Mode	R03h	1030 h	
		Display Control 3	R09h	0001 h	
		Display Control 4	R0Ah	0008 h	
		RGB I/F Control 1	R0Ch	0000 h	
		FMARK Position	R0Dh	0000 h	
		VCOML voltage Control	R0Eh	0030 h	
		RGB I/F Control 2	R0Fh	0000 h	
		Window Horizontal RAM Start Address	R50h	0000 h	
		Window Horizontal RAM End Address	R51h	00EF h	
		Window Vertical RAM Start Address	R52h	0000 h	
		Window Vertical RAM End Address	R53h	013F h	
12	Partical Display Control	Partial Image Display Position	R80h	0000 h	
		Partial Image RAM Start Line Address	R81h	0000 h	
		Partial Image RAM End Line Address	R82h	0000 h	

(2/2)

No.		Function	Register	recommend	Remarks
13	Panel interface Control	Panel interface control 1-1	R91h	0003 h	
		Panel interface control 2	R92h	0100 h	
		Panel interface control 3	R93h	0201 h	
		Panel interface control 4	R94h	0001 h	
		Back Light Control	RC0h	0000 h	
14	Test Register	Test Register	RF3h	0020 h	
15	Address Setting	Horizontal RAM Address Set	R20h	0000 h	
		Vertical RAM Address Set	R21h	0000 h	
	Data transfer	GRAM Data Write	R22h	**** h	
16	Display ON	Display Control 1	R07h	0100 h	
17	Wait	wait 34 msec(2 frame) or more			
18	Back-Light ON				

11.2 Power OFF Sequence

No.		Function	Register	recommend	Remarks
1	Power OFF	Display Control 1	R07h	0000 h	BASEE=0
2	Power Control	Power Control 3	R12h	018C h	PS0N=0, PON=0
3	Wait	wait 120 msec or more			
4		VCI,IOVCC OFF			

11.3 Deep-Standby Sequence

No.		Function	Register	recommend	Remarks
1	Display OFF	Display Control 1	R07h	0000 h	BASEE=0
2	Power Control	Power Control 3	R12h	018C h	PS0N=0, PON=0
3	Wait	wait 1 frame or more			
4	Power Control	Power Control 1	R10h	0634 h	

11.4 Deep-Standby Release Sequence

No.		Function	Register	recommend	Remarks
1	Dummy	DB = 0000 h		0000 h	
		DB = 0000 h		0000 h	
2	Wait	wait 1 msec or more			
3	Dummy	DB = 0000 h		0000 h	
		DB = 0000 h		0000 h	
		DB = 0000 h		0000 h	
		DB = 0000 h		0000 h	
3	Wait	wait 1 msec or more			
4	Power ON Sequence	Power ON Sequence No.7 --			

11.5 Refresh Sequence

To prevent false operation by static electricity and such, please refresh register setting as follows regularly.

No.		機能	レジスタ	推奨値	備考
1	data transfer synchronization	RS=0	-	0000 h	
		RS=0	-	0000 h	
		RS=0	-	0000 h	
		RS=0	-	0000 h	
2		NVM Calibration	RA4h	0001 h	
3	Wait	0.2msec or more			
4	Instruction user setting	Driver Output Control 2	R60h	A700 h	
		Display Control 2	R08h	0503 h	
		Gammma Control 1	R30h	0500 h	
		Gammma Control 2	R31h	3711 h	
		Gammma Control 3	R32h	0605 h	
		Gammma Control 4	R33h	120D h	
		Gammma Control 5	R34h	1202 h	
		Gammma Control 6	R35h	0D0A h	
		Gammma Control 7	R36h	3506 h	
		Gammma Control 8	R37h	1107 h	
		Gammma Control 9	R38h	0005 h	
		Gammma Control 10	R39h	0212 h	
		Panel I/F Control 1	R90h	001D h	
		Power Control 1	R10h	0310 h	
		Power Control 2	R11h	0231 h	
		Power Control 3	R13h	1400 h	
Power Control 4	R12h	01BC h			
5	Wait	wait 100 msec or more			
		Driver Output Control 1	R01h	0500 h	
		LCD Driving Control	R02h	0200 h	
		Entry Mode	R03h	1030 h	
		Display Control 3	R09h	0001 h	
		Display Control 4	R0Ah	0008 h	
		RGB I/F Control 1	R0Ch	0000 h	
		FMARK Position	R0Dh	0000 h	
		VCOML voltage Control	R0Eh	0030 h	
		RGB I/F Control 2	R0Fh	0000 h	
		Window Horizontal RAM Start Address	R50h	0000 h	
		Window Horizontal RAM End Address	R51h	00EF h	
		Window Vertical RAM Start Address	R52h	0000 h	
		Window Vertical RAM End Address	R53h	013F h	
		Base Image Display Control	R61h	0000 h	
Vertical Scroll Control	R6Ah	0000 h			
6	Partical Display Control	Partial Image Display Position	R80h	0000 h	
		Partial Image RAM Start Line Address	R81h	0000 h	
		Partial Image RAM End Line Address	R82h	0000 h	
7	Panel interface Control	Panel interface control 1-1	R91h	0003 h	
		Panel interface control 2	R92h	0100 h	
		Panel interface control 3	R93h	0201 h	
		Panel interface control 4	R94h	0001 h	
		Back Light Control	RC0h	0000 h	
8	Test Register	Test Register	RF3h	0020 h	
9	Address Setting	Horizontal RAM Address Set	R20h	0000 h	
		Vertical RAM Address Set	R21h	0000 h	
	Data transfer	GRAM Data Write	R22h	**** h	
10	Display ON	Display Control 1	R07h	0100 h	

11.6 Power Supply ON Sequence

We recommend that you supplied at the same time VCI and IOVCC.
However, there is no problem even if the supply IOVCC later than VCI.
Please release the reset from at least 1ms after each power supply.

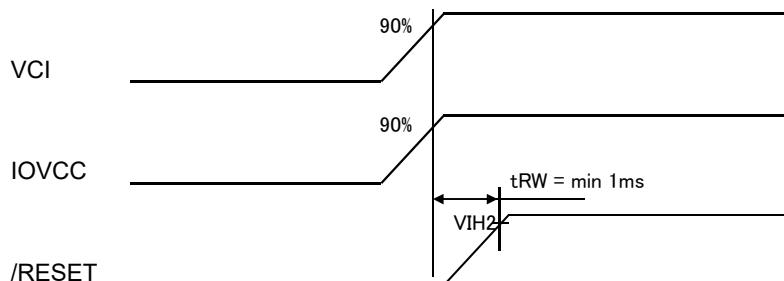

11.7 Power Supply OFF Sequence

We recommend that you removed at the same time VCI and IOVCC.
However, there is no problem even if IOVCC OFF faster than VCI .

12. About LED Driving Circuit

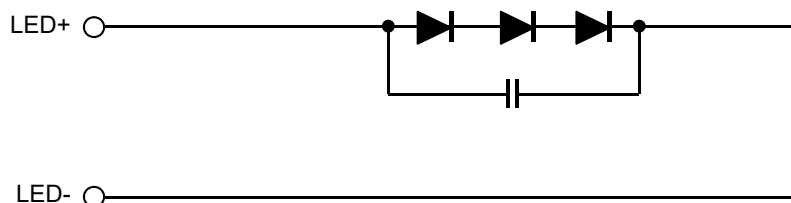

13. Characteristics

13.1 Optical Characteristics

< Measurement Condition >

Measuring instruments: CS2000 (KONICA MINOLTA), LCD7200(OTSUKA ELECTRONICS),
EZcontrast160D (ELDIM)

Driving condition: VCI=IOVCC=2.8V
Optimized VCOMDC

Backlight: IL=5mA

Measured temperature: Ta=25° C

Item	Symbol	Condition	MIN	TYP	MAX	Unit	Note No.	Remark	
Response time	Rise time	TON	[Data]= 00h→3Fh	—	—	60	ms	1 ※	
	Fall time	TOFF	[Data]= 3Fh→00h	—	—	40	ms		
Contrast ratio	Backlight ON	CR	[Data]= 3Fh / 00h	—	800	—		2	
	Backlight OFF			—	3.5	—			
Viewing angle	Left	θL	[Data]= 3Fh / 00h CR ≥ 10	—	80	—	deg	3 ※	
	Right			θR	—	80			—
	Up			φU	—	80			—
	Down			φD	—	80			—
White Chromaticity	x	[Data]=3Fh	White chromaticity range				4		
	y								
Burn-in			No noticeable burn-in image should be observed after 2 hours of window pattern display.				5		
Center brightness		[Data]=3Fh	280	400	—	cd/m ²	6		
Brightness distribution		[Data]=3Fh	70	—	—	%	7		

* Note number 1 to 7: Refer to the APPENDIX of "Reference Method for Measuring Optical Characteristics".

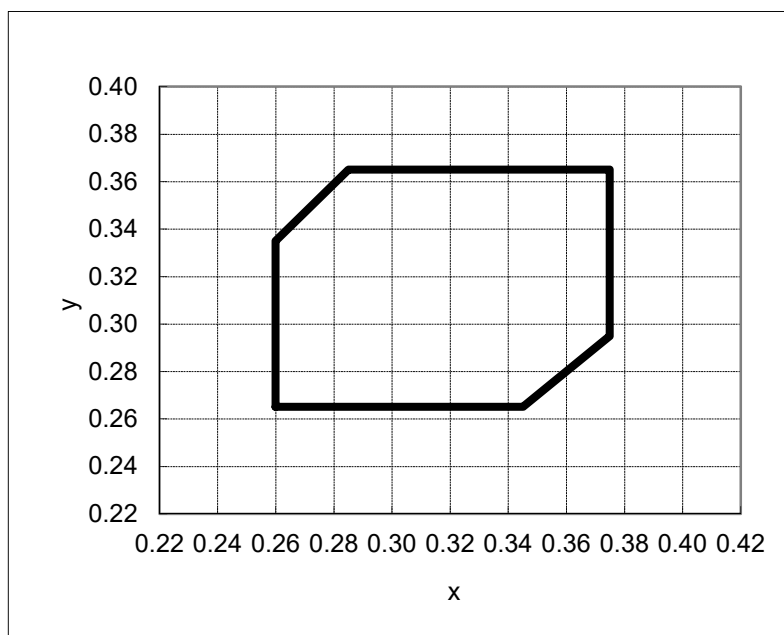

【White Chromaticity Range】

x	y
0.260	0.265
0.345	0.265
0.375	0.295
0.375	0.365
0.285	0.365
0.260	0.335

White Chromaticity Range

13.2 Temperature Characteristics

< Measurement Condition >

Measuring instruments: CS2000 (KONICA MINOLTA), LCD7200(OTSUKA ELECTRONICS)

Driving condition: VCI=IOVCC=2.8V

Optimized VCOMDC

Backlight: IL=5mA

Item			Specification		Remark
			Ta=-20°C	Ta=70°C	
Contrast ratio		CR	200 or more	200 or more	Backlight ON
Response time	Rise time	TON	300 msec or less	50 msec or less	※
	Fall time	TOFF	200 msec or less	30 msec or less	※
Display Quality			No noticeable display defect or uniformity should be observed.		Use the criteria for judgment specified in the section 14.

13.3 Service Life of Backlight

< Definition >

When the center luminance drops to 50% of the initial value, the back light is considered to have reached the end of its effective service life.

Backlight: IL=5mA

	Average life	Ambient temperature
Continuously lit	50,000hrs	25±5°C

Average life means the period which the survival rate falls under 50%.

14. Criteria of Judgment

14.1 Defective Display and Screen Quality

Test Condition:	Observed TFT-LCD monitor from front during operation with the following conditions
Driving Signal	Raster Patter (RGB, white, black)
Signal condition	[Data]: 3Fh, 2Ah, 00h (3steps)
Observation distance	30 cm
Illuminance	200 to 350 lx
Backlight	IL=5mA

Defect item	Defect content	Criteria		
Display Quality	Line defect	Black, white or color line, 3 or more neighboring defective dots	Not exists	
	Dot defect	Uneven brightness on dot-by-dot base due to defective TFT or CF, or dust is counted as dot defect (brighter dot, darker dot)	Refer to table 1	
		High bright dot: Visible through 2% ND filter at [Data]=00h	ignored	
		Low bright dot: Visible through 5% ND filter at [Data]=00h Dark dot: Appear dark through white display at [Data]=2Ah Inisible through 5% ND filter at [Data]=00h		
Screen Quality	Dirt	Uneven brightness (white stain, black stain etc)	Invisible through 1% ND filter	
	Foreign particle	Point-like	$0.25\text{mm} < \varphi$	$N=0$
			$0.20\text{mm} < \varphi \leq 0.25\text{mm}$	$N \leq 2$
			$\varphi \leq 0.20\text{mm}$	Ignored
		Liner	$3.0\text{mm} < \text{length and } 0.08\text{mm} < \text{width}$	$N=0$
	$\text{length} \leq 3.0\text{mm}$ or $\text{width} \leq 0.08\text{mm}$		Ignored	
Others		Use boundary sample for judgment when necessary		

$\varphi(\text{mm})$: Average diameter = (major axis + minor axis)/2
Permissible number: N

Table 1

Area	High bright dot	Low bright dot	Dark dot	Total	Criteria
A	0	2	2	3	Permissible distance between same color bright dots (includes neighboring dots): 3 mm or more Permissible distance between same color high bright dots (includes neighboring dots): 5 mm or more
B	2	4	4	5	
Total	2	4	4	5	

<Portrait model>

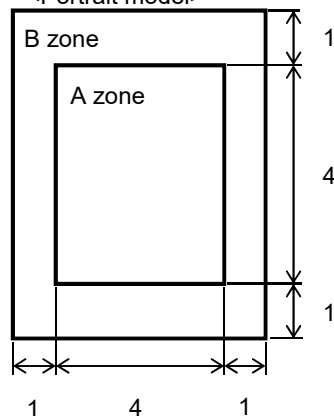

Division of A and B areas

B area: Active area

Dimensional ratio between A and B areas: 1: 4: 1 (Refer to the left figure)

14.2 Screen and Other Appearance

Testing conditions

Observation distance	30cm
Illuminance	1200~2000 lx

Item	Criteria	Remark
Polarizer Flaw Stain Bubble Dust Dent	Ignore invisible defect when the backlight is on.	Applicable area: Active area only (Refer to the section 3.2 "Outward form")
S-case	No functional defect occurs	
FPC cable	No functional defect occurs	

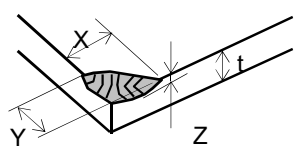
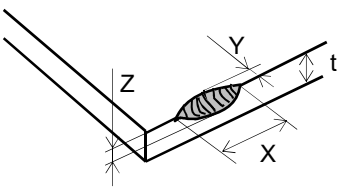
Item	Appearance	Criteria
Glass Chipping	Corner area 	Unit: mm $X \leq 3$ $Y \leq 3$ $Z \leq t$ (t:glass thickness) $X, Y \leq 0.5$ is ignored.
	Others 	Unit: mm $X \leq 5$ $Y \leq 1$ $Z \leq t$ (t:glass thickness) $X, Y \leq 0.5$ is ignored.
	Progressive crack	None

15. Reliability Test

Test item		Test condition		number of failures /number of examinations
Durability test	High temperature storage	Ta=80° C	240hrs	0 / 3
	Low temperature storage	Ta=-30° C	240hrs	0 / 3
	High temperature & high humidity storage	Ta=60° C, RH=90% non condensing	240hrs	0 / 3
	High temperature operation	Tp=70° C	240hrs	0 / 3
	Low temperature operation	Tp=-20° C	240hrs	0 / 3
	High temp & humid operation	Tp=40° C, RH=90% non condensing	240hrs	0 / 3
	Thermal shock storage	-30←→80° C(30min/30min)	100 cycles	0 / 3
	Lightfastness	Xenon Blackpanel 63±3°C non-shower 450W/m ² (300~700nm) non-operating Integral dose 800MJ/m ²		0 / 3
Mechanical environmental test	Electrostatic discharge test (Non operation)	Confirms to EIAJ ED-4701/300 C=200pF,R=0Ω,V=±200V Each 3 times of discharge on and power supply and other terminals.		0 / 3
	Surface discharge test (Non operation)	C=250pF, R=100Ω, V=±8kV Each 5 times of discharge in both polarities on the center of screen with the case grounded.		0 / 3
	Vibration test	Total amplitude 1.5mm, f=10~55Hz, X,Y,Z directions for each 2 hours		0 / 3
	Impact test	Use TOPPAN PRINTING original jig (see next page)and make an impact with peak acceleration of 1000m/s ² for 6 msec with half sine-curve at 3 times to each X, Y, Z directions in conformance with JIS C 60068-2-27-2011.		0 / 3
Packing test	Packing vibration-proof test	Acceleration of 19.6m/s ² with frequency of 10→55→10Hz, X,Y, Zdirection for each 30 minutes		0 / 1 Packing
	Packing drop test	Drop from 75cm high. 1 time to each 6 surfaces, 3 edges, 1 corner		0 / 1 Packing

Note: Ta=ambient temperature Tp=Panel temperature

※ The profile of high temperature/humidity storage and High Temperature/humidity operation
(Pure water of over 10MΩ·cm shall be used.)

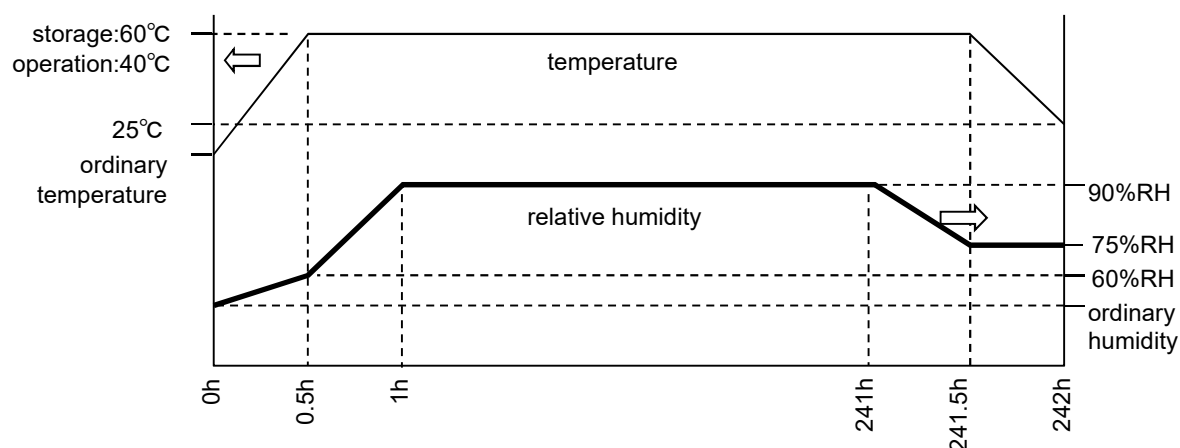
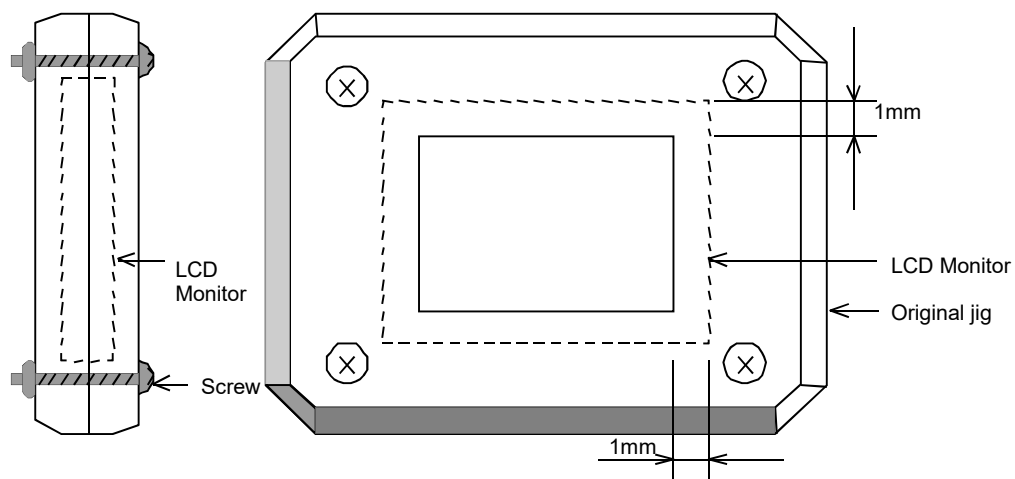

Table2.Reliability Criteria

The parameters should be measured after leaving the monitor at the ordinary temperature for 24 hours or more after the test completion.

item	Standard	Remarks
Display quality	No visible abnormality shall be seen.	
Contrast ratio	40 or more	Backlight ON

TOPPAN PRINTING Original Jig



16. Packing Specifications

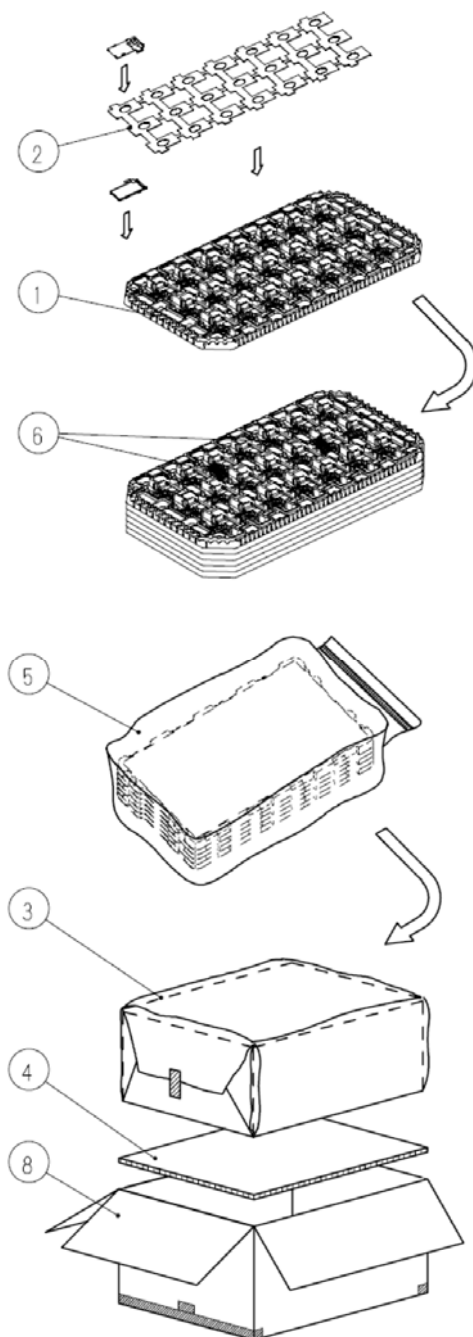

Step1. Each product is to be placed in one of the cut-outs of the tray with it's the LCD display side facing upward,and foam-sheet is put on products.(21 pieces/1 step)
Each product is to be placed on the FORM SHEET with the LCD display surface facing downward.(42 pieces/trays)

Step 2. Each tray filled with products is to be piled up in stack of 5.
One empty tray is to be put on the top of stack of 5 trays.

Step 3. 2 packs of moisture absorbers are to be placed on the top tray as shown in the drawing.
Put piled trays into a sealing bag.

Step 4. Vacuum and seal the bag with the vacuum sealing machine.

Step 5. The piled trays are to be wrapped with a bubble cushioning sheet, and to be fixed with adhesive tape.

Step 6. A corrugated board is to be placed in the bottom of an outer carton.
The wrapped trays are to be put on the corrugated board in the outer carton.
Another corrugated board is to be placed on the top of the inserted carton box.

Step 7. The outer carton is to be sealed in H-shape with packing tape as shown in the drawing.
The model number, quantity of products, and shipping date are to be printed on the 2 opposite side of the outer carton with black ink.
If necessary, shipping labels or impression markings are to be put on the outer carton.

Step 8. The outer carton is to be inserted into a extra outer carton with same direction.
The extra outer carton needs to sealed with in H-shape with packing tape as shown in the drawing.

Step 9. The model number, quantity of products, and shipping date are to be printed on the 2 opposite sides of the extra outer carton with black ink.
If necessary, shipping labels or impression markings are to be put on the extra outer carton.

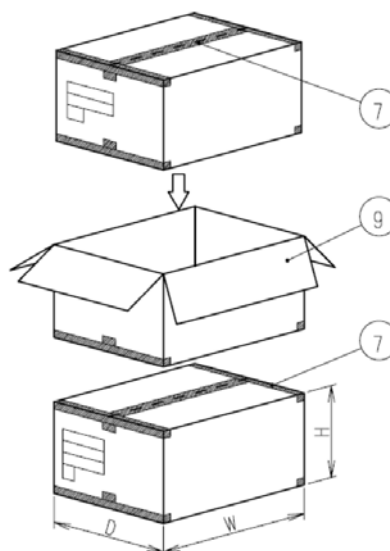

Remark: The return of packing materials is not required.

Packing item name	Specs., Material
① Tray	A-PET(Antistatic)
② Foam sheet	Antistatic Polyethylene
③ B sheet A	Antistatic air babble sheet
④ Inner board	Corrugated cardboard
⑤ Sealing bag	
⑥ Drier	Moisture absorber
⑦ Packing tape	
⑧ Outer carton	Corrugated cardboard
⑨ Extra outer carton	Corrugated cardboard

Dimension of extra outer carton	
D : Approx.	337mm
W : Approx.	618mm
H : Approx.	179mm
Quantity of products packed in one carton:	210
Gross weight : Approx.	5.0kg

17. Handling Instruction

17.1 Cautions for Handling LCD panels

**Caution**

- (1) Do not make an impact on the LCD panel glass because it may break and you may get injured from it.
- (2) If the glass breaks, do not touch it with bare hands.
(Fragment of broken glass may stick you or you cut yourself on it.)
- (3) If you get injured, receive adequate first aid and consult a medial doctor.
- (4) Do not let liquid crystal get into your mouth.
(If the LCD panel glass breaks, try not let liquid crystal get into your mouth even toxic property of liquid crystal has not been confirmed.)
- (5) If liquid crystal adheres, rinse it out thoroughly.
(If liquid crystal adheres to your cloth or skin, wipe it off with rubbing alcohol or wash it thoroughly with soap. If liquid crystal gets into eyes, rinse it with clean water for at least 15 minutes and consult an eye doctor.)
- (6) If you scrap this products, follow a disposal standard of industrial waste that is legally valid in the community, country or territory where you reside.
- (7) Do not connect or disconnect this product while its application products is powered on.
- (8) Do not attempt to disassemble or modify this product as it is precision component.
- (9) If a part of soldering part has been exposed, and avoid contact (short-circuit) with a metallic part of the case etc. about FPC of this model, please.
Please insulate it with the insulating tape etc. if necessary.
The defective operation is caused, and there is a possibility to generation of heat and the ignition.
- (10) Since excess current protection circuit is not built in this TFT module, there is the possibility that LCD module or peripheral circuit become feverish and burned in case abnormal operation is generated.
We recommend you to add excess current protection circuit to power supply.
- (11) The devices on the FPC are damageable to electrostatic discharge, because the terminals of the devices are exposed.
Wear grounded wrist-straps and use electrostatic neutralization blowers to prevent static charge and discharge when handling the TFT monitors.
Designate an appropriate operating area, and set equipment, tools, and machines properly when handling this product.

**Caution**

This mark is used to indicate a precaution or an instruction which, if not correctly observed, may result in bodily injury, or material damages alone.

17.2 Precautions for Handling

- 1) Wear finger tips at incoming inspection and for handling the TFT monitors to keep display quality and keep the working area clean.
Do not touch the surface of the monitor as it is easily scratched.
- 2) Wear grounded wrist-straps and use electrostatic neutralization blowers to prevent static charge and discharge when handling the TFT monitors as the LED in this TFT monitors is damageable to electrostatic discharge.
Designate an appropriate operating area, and set equipment, tools, and machines properly when handling this product.
- 3) Avoid strong mechanical shock including knocking, hitting or dropping to the TFT monitors for protecting their glass parts. Do not use the TFT monitors that have been experienced dropping or strong mechanical shock.
- 4) Do not use or storage the TFT monitors at high temperature and high humidity environment. Particularly, never use or storage the TFT monitors at a location where condensation builds up.
- 5) Avoid using and storing TFT monitors at a location where they are exposed to direct sunlight or ultraviolet rays to prevent the LCD panels from deterioration by ultraviolet rays.
- 6) Do not stain or damage the contacts of the FPC cable .
FPC cable needs to be inserted until it can reach to the end of connector slot.
During insertion, make sure to keep the cable in a horizontal position to avoid an oblique insertion.
Otherwise, it may cause poor contact or deteriorate reliability of the FPC cable.
- 7) The FPC cable is a design very weak to the bend and the pull as it is fixed with the tape.
Do not bend or pull the FPC cable or carry the TFT monitor by holding the FPC cable.
- 8) Peel off the protective film on the TFT monitors during mounting process.
Refer to the section 17.5 on how to peel off the protective film.
We are not responsible for electrostatic discharge failures or other defects occur when peeling off the protective film.
- 9) Please make it to the structure to suppress surroundings of the front polarizer for the display irregularity prevention.

17.3 Precautions for Operation

- 1) Since this TFT monitors are not equipped with light shielding for the driver IC, do not expose the driver IC to strong lights during operation as it may cause functional failures.
- 2) In case of powering up or powering off this LCD module, be sure to comply the sequence as instructed in this specification.
- 3) Do not plug in or out the FPC cable while power supply is switch on.
Plug the FPC cable in and out while power supply is switched off.
- 4) Do not operate the TFT monitors in the strong magnetic field. It may break the TFT monitors.
- 5) Do not display a fixed image on the screen for a long time.
Use a screen-saver or other measures to avoid a fixed image displayed on the screen for a long time.
Otherwise, it may cause burn-in image on the screen due the characteristics of liquid crystal.

17.4 Storage Condition for Shipping Cartons

Storage environment

- Temperature 0 to 40° C
- Humidity 60%RH or less
No-condensing occurs under low temperature with high humidity condition.
- Atmosphere No poisonous gas that can erode electronic components and/or wiring materials should be detected.
- Time period 1 year
- Unpacking To prevent damages caused by static electricity, anti-static precautionary measures (e.g. earthing, anti-static mat) should be implemented.
- Maximum piling up 7 cartons

*Conditions to storage after unpacking

Storage environment

- Temperature 0 to 40° C
- Humidity 60%RH or less
No-condensing occurs under low temperature with high humidity condition.
- Atmosphere No poisonous gas that can erode electronic components and/or wiring materials should be detected.
- Time period 1 year (Shelf life)
- Others Keep/ store away from direct sunlight
Storage goods on original tray made by ORTUS.

17.5 Precautions for Peeling off the Protective film

The followings work environment and work method are recommended to prevent the TFT monitors from static damage or adhesion of dust when peeling off the protective films.

A) Work Environment

- a) Humidity: 50 to 70 %RH, Temperature 15 to 27 ° C
- b) Operators should wear conductive shoes, conductive clothes, conductive finger tips and grounded wrist-straps. Anti-static treatment should be implemented to work area's floor.
- c) Use a room shielded against outside dust with sticky floor mat laid at the entrance to eliminate dirt.

B) Work Method

The following procedures should taken to prevent the driver ICs from charging and discharging.

- a) Use an electrostatic neutralization blower to blow air on the TFT monitors to its lower right when FPC is placed at the right.
Optimize direction of the blowing air and the distance between the TFT monitors and the electrostatic neutralization blower.
- b) Put an adhesive tape (Scotch tape, etc) at the lower right corner area of the protective film to prevent scratch on surface of TFT monitors.
- c) Peel off the adhesive tape slowly (spending more than 2 secs to complete) by pulling it to opposite direction.

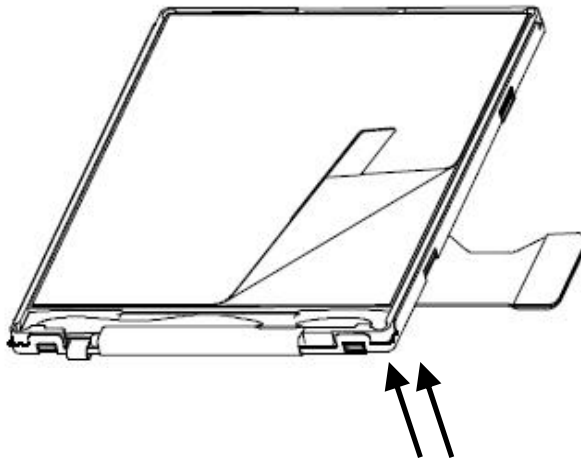

Direction of blowing air
(Optimize air direction and the distance)

17.6 Warranty

TOPPAN PRINTING is only liable to defective goods which is stored and used under the condition complying with this specifications and returned within 1 (one) year.

Warranty caused by manufacturing defect shall be conducted by replacement of goods or refundment at unit price.

APPENDIX

Reference Method for Measuring Optical Characteristics and Performance

1. Measurement Condition (Backlight ON)

Measuring instruments: CS2000 (KONICA MINOLTA), LCD7200(OTSUKA ELECTRONICS), EZcontrast160D (ELDIM)

Driving condition: Refer to the section "Optical Characteristics"

Measured temperature: 25°C unless specified

Measurement system: See the chart below. The luminance meter is placed on the normal line of measurement system.

Measurement point: At the center of the screen unless otherwise specified

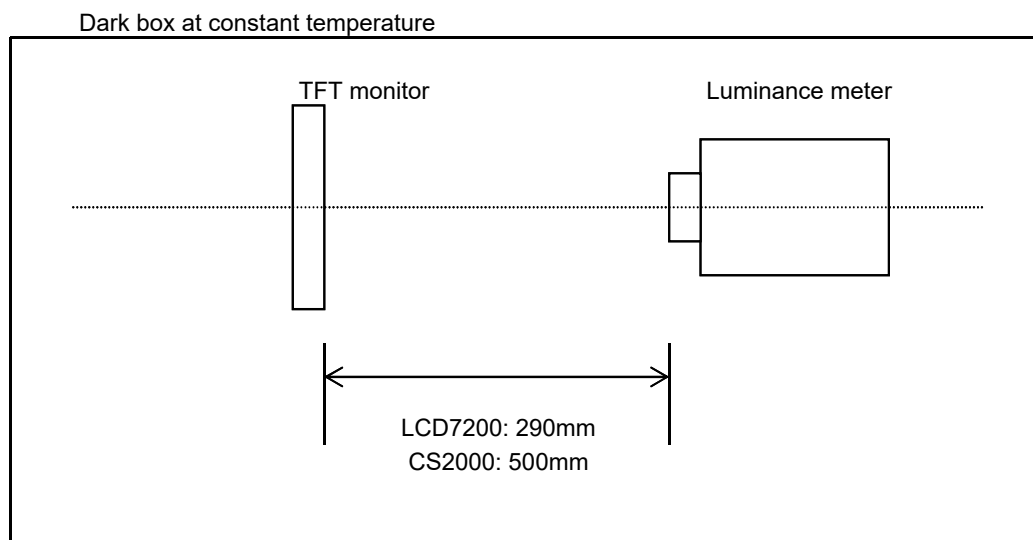

Measurement is made after 30 minutes of lighting of the backlight.

Measurement point: At the center point of the screen
Brightness distribution: 9 points shown in the following drawing.

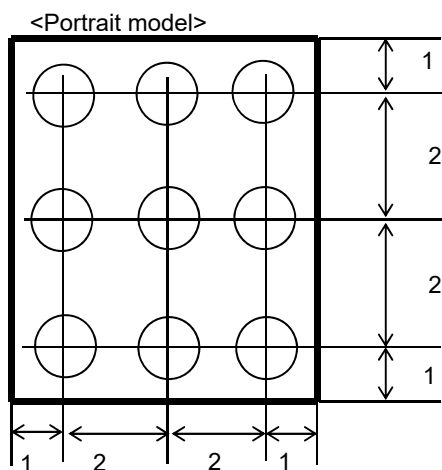

Dimensional ratio of active area

Backlight IL=5mA

Measurement Condition (Contrast ratio Backlight OFF only)

- Measuring instruments: LCD7200(OTSUKA ELECTRONICS),Ring Light(40,000 lx, ϕ 58)
- Driving condition: Refer to the section "Optical Characteristics"
- Measured temperature: 25°C unless specified
- Measurement system: See the chart below.
- Measurement point: At the center of the screen.

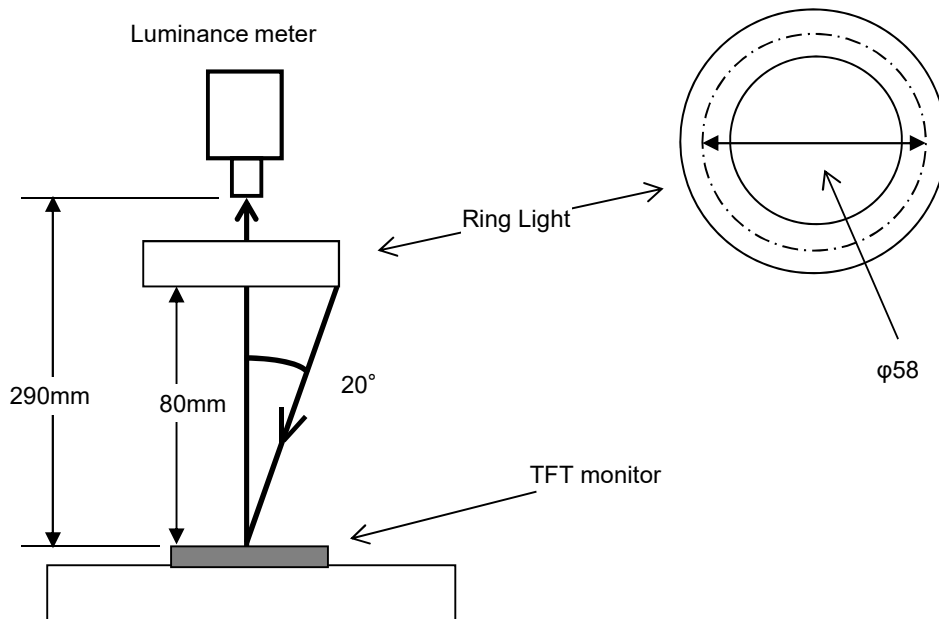

2. Test Method

Notice	Item	Test method	Measuring instrument	Remark
1	Response time	<p>Measure output signal waveform by the luminance meter when raster of window pattern is changed from white to black and from black to white.</p> <p style="text-align: center;">Black White Black</p> <p>White brightness</p> <p>100%</p> <p>90%</p> <p>10%</p> <p>0%</p> <p>Black brightness</p> <p>TON</p> <p>TOFF</p>	LCD7200	Black display [Data]=00h White display [Data]=3Fh TON Rise time TOFF Fall time
2	Contrast ratio	<p>Measure maximum luminance Y1([Data]=3Fh) and minimum luminance Y2([Data]=00h) at the center of the screen by displaying raster or window pattern. Then calculate the ratio between these two values.</p> <p style="text-align: center;">Contrast ratio = Y1/Y2</p> <p style="text-align: center;">Diameter of measuring point: 7.8mmφ(CS2000)</p> <p style="text-align: center;">Diameter of measuring point: 3mmφ(LCD7200)</p>	CS2000 LCD7200	Backlight ON Backlight OFF
3	Viewing angle Horizontalθ Verticalφ	Move the luminance meter from right to left and up and down and determine the angles where contrast ratio is 10.	EZcontrast160D	
4	White chromaticity	<p>Measure chromaticity coordinates x and y of CIE1931 colorimetric system at [Data] = 3Fh</p> <p style="text-align: center;">Color matching function: 2°view</p> <p style="text-align: center;">Measurement angle: 1°</p>	CS2000	
5	Burn-in	Visually check burn-in image on the screen after 2 hours of "window display" ([Data]=3Fh/00h).		At optimized VCOMDC
6	Center brightness	Measure the brightness at the center of the screen.	CS2000	
7	Brightness distribution	<p>(Brightness distribution) = 100 x B/A %</p> <p>A : max. brightness of the 9 points</p> <p>B : min. brightness of the 9 points</p>	CS2000	