

Dept
 Qty
 DC 1
 ED 1
 IE 1
 ISO 1
 PD 1
 R&D 1
 SD 1
 QA 1
 QC 1
 QE 1

1 2 3 4 5 6 7 8

REV.	DESCRIPTION	DRAWN	CHECKED	APPROVED
A	NEW RELEASE	JLZ 05/09/18'		

NOTES:

1. SPECIFICATIONS

- . Switch Function: Single Pole Single Throw
- . Contact Rating: 50mA at 12Vdc
- . Insulation Resistance:100MΩ min.
- . Contact Resistance:150mΩ max.
- . Operating Life:100,000 cycles
- . Travel:0.3+0.3mm
- . Operation Temperature Range: -25°C to +70°C

. Wave Soldering: Recommended Solder Temperature At 500°f(260°C)max. 5 Seconds,Subject To PCB 1.6mm Thickness.

2. PRODUCT NUMBER CODE:

DS1042-17 - X X X X X X X

- Operating Life
10:100,000 cycles
- Operating force
030: 30±20gf
- Packing type
A: polybag
R: tape & reel
- Actuator color
B: Black
- Housing color
B: Black
- Profile Height(DIM. H)
052:5.2mm
- No. of contacts
2: 2Pos

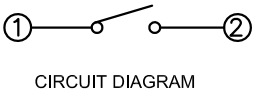
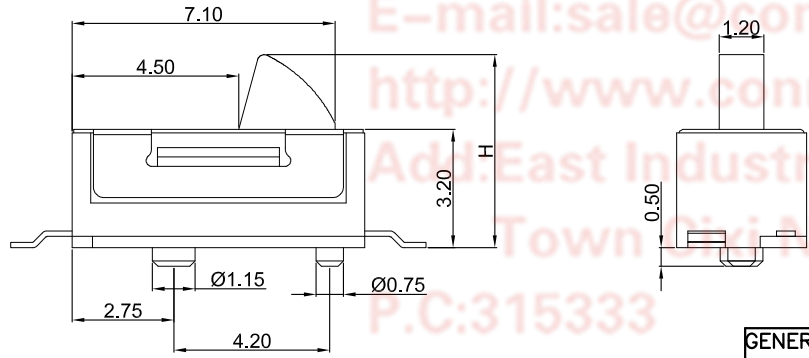
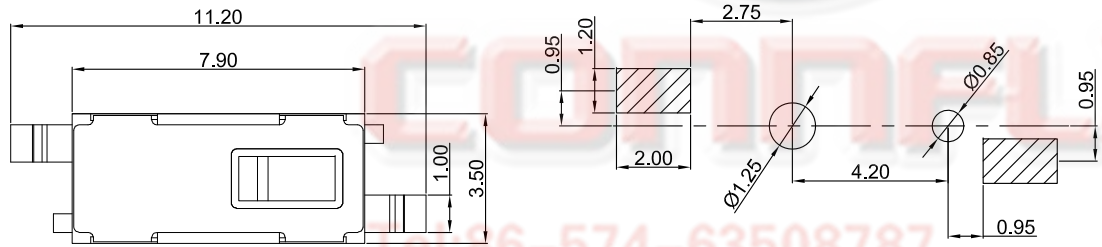

Tel:86-574-63508787
 Fax:86-574-63510817
 E-mail:sale@connfly.com
 http://www.connfly.com
 Add:East Industry Zone KuangYan
 Town Ningbo China
 P.C:315333

GENERAL TOLERANCE		ANGLE TOLERANCE		PROJECTION		TITLE	Detector Switch
X.	±0.60	X.	±5°	UNITS	mm	SMT Type 7.9mmX3.5mm	
.X	±0.38	.X	±3°	SHEET SIZE	A4	SERIES	DS1042-17 SERIES
.XX	±0.25	.XX	±2°	晨翔电子有限公司 CONNFLY CONNFLY ELECTRONIC CO. LTD			
DRAWING TYPE		CUSTOMER					
SCALE		1:1 SHEET 1 OF 1					
DRAWING NO.		C-DS1042-17-XXXXX-A					

1 2 3 4 5 6 7 8