



UTT12P10

Power MOSFET

-100V, -12A P-CHANNEL POWER MOSFET

DESCRIPTION

The UTC **UTT12P10** is a P-channel power MOSFET using UTC's advanced technology to provide the customers with high switching speed, cost-effectiveness and a minimum on-state resistance. It can also withstand high energy in the avalanche.

FEATURES

- * $R_{DS(ON)} \leq 0.2 \Omega$ @ $V_{GS} = -10V, I_D = -12A$
- * High Switching Speed

SYMBOL

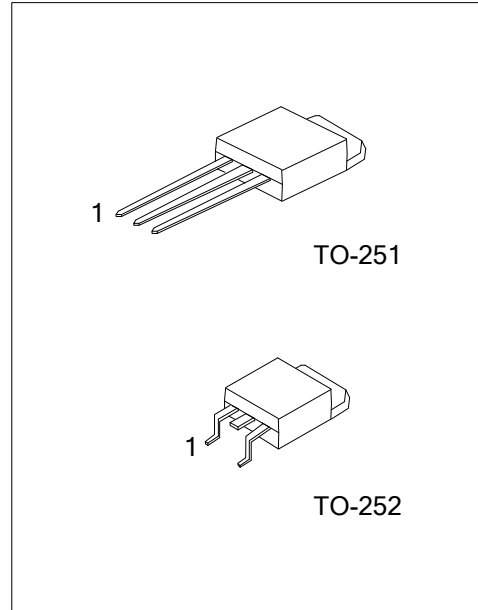
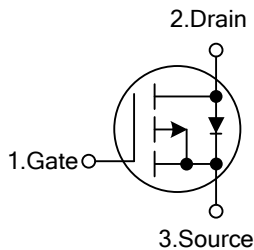

ORDERING INFORMATION

Ordering Number		Package	Pin Assignment			Packing
Lead Free	Halogen Free		1	2	3	
UTT12P10L-TM3-T	UTT12P10G-TM3-T	TO-251	G	D	S	Tube
UTT12P10L-TN3-R	UTT12P10G-TN3-R	TO-252	G	D	S	Tape Reel

Note: Pin Assignment: G: Gate D: Drain S: Source

<p>UTT12P10G-TM3-T</p> <p>(1) Packing Type (2) Package Type (3) Green Package</p>	<p>(1) T: Tube, R: Tape Reel (2) TM3: TO-251, TN3: TO-252 (3) G: Halogen Free and Lead Free, L: Lead Free</p>
---	---

MARKING

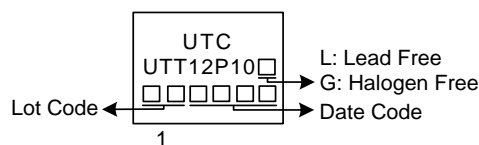

■ ABSOLUTE MAXIMUM RATINGS (T_J=25°C, unless otherwise specified)

PARAMETER		SYMBOL	RATINGS	UNIT
Drain-Source Voltage		V _{DSS}	-100	V
Gate-Source Voltage		V _{GSS}	±20	V
Drain Current	Continuous, V _{GSS} @-10V	I _D	-12	A
	Pulsed (Note 2)	I _{DM}	-48	A
	Single Pulsed (Note 2)	E _{AS}	60	mJ
Power Dissipation (T _C =25°C)		P _D	125	W
Junction Temperature		T _J	+150	°C
Storage Temperature		T _{STG}	-55 ~ +150	°C

- Notes: 1. Absolute maximum ratings are those values beyond which the device could be permanently damaged. Absolute maximum ratings are stress ratings only and functional device operation is not implied.
 2. Repetitive rating; pulse width limited by max. junction temperature.
 3. V_{DD}=-25V, starting T_J=25°C, L=0.83mH, R_G=25Ω, I_{AS}=12A. (See Figure 2)

■ THERMAL DATA

PARAMETER	SYMBOL	RATINGS	UNIT
Junction to Case	θ _{JC}	1.0	°C/W

■ ELECTRICAL CHARACTERISTICS (T_J=25°C, unless otherwise specified)

PARAMETER		SYMBOL	TEST CONDITIONS	MIN	TYP	MAX	UNIT	
OFF CHARACTERISTICS								
Drain-Source Breakdown Voltage		BV _{DSS}	I _D =-250μA, V _{GS} =0V	-100			V	
Drain-Source Leakage Current		I _{DSS}	V _{DS} =-100V, V _{GS} =0V			-1	μA	
Gate- Source Leakage Current	Forward	I _{GSS}	V _{GS} =+20V			+100	nA	
	Reverse		V _{GS} =-20V			-100	nA	
ON CHARACTERISTICS								
Gate Threshold Voltage		V _{GS(TH)}	V _{DS} =V _{GS} , I _D =-250μA	-1.0		-3.0	V	
Static Drain-Source On-State Resistance		R _{DS(ON)}	V _{GS} =-10V, I _D =-12A (Note 2)			0.2	Ω	
DYNAMIC PARAMETERS								
Input Capacitance		C _{ISS}	V _{DS} =-25V, V _{GS} =0V, f=1.0MHz		1400		pF	
Output Capacitance		C _{OSS}				590		pF
Reverse Transfer Capacitance		C _{RSS}				140		pF
SWITCHING PARAMETERS								
Total Gate Charge		Q _G	V _{DS} =-80V, V _{GS} =-10V, I _D =-12A, See Fig 3 (Note 2)		35	40	nC	
Gate to Source Charge		Q _{GS}				8		nC
Gate to Drain ("Miller") Charge		Q _{GD}				6		nC
Turn-ON Delay Time		t _{D(ON)}	V _{DD} =-50V, I _D =-12A, R _G =9.1Ω, R _D = 2.4Ω, See Fig. 1(Note 2)		40	50	ns	
Rise Time		t _R				38	45	ns
Turn-OFF Delay Time		t _{D(OFF)}				314	330	ns
Fall-Time		t _F				66	75	ns
SOURCE- DRAIN DIODE RATINGS AND CHARACTERISTICS								
Maximum Body-Diode Continuous Current		I _S				-12	A	
Maximum Body-Diode Pulsed Current		I _{SM}	(Note 1)			-48	A	
Drain-Source Diode Forward Voltage		V _{SD}	T _J =25°C, I _S =-12A, V _{GS} =0V (Note 2)			-5.0	V	
Body Diode Reverse Recovery Time		t _{rr}	T _J =25°C, I _F =-12A,		130	260	ns	
Body Diode Reverse Recovery Charge		Q _{rr}	di/dt=100A/μs (Note 2)		0.35	0.70	μC	

- Notes: 1. Repetitive rating; pulse width limited by max. junction temperature.
 2. Pulse width ≤ 300μs; duty cycle ≤ 2%.

TEST CIRCUITS AND WAVEFORMS

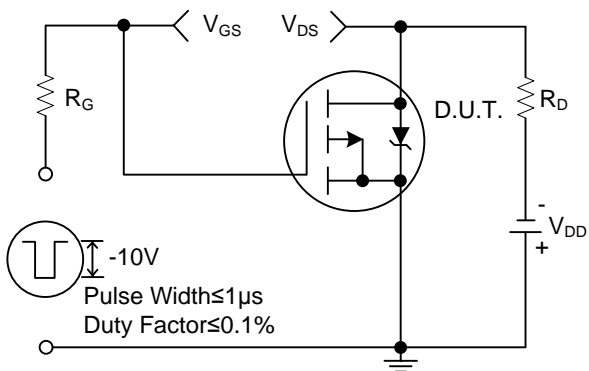

Fig. 1a Switching Time Test Circuit

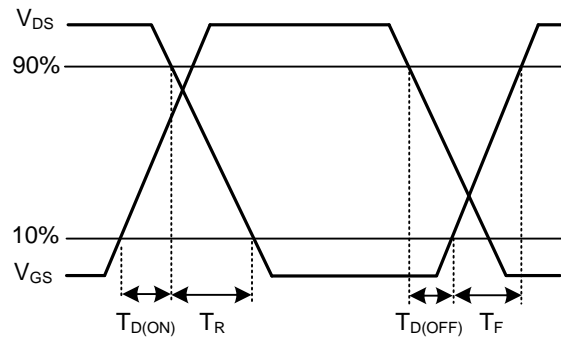

Fig. 1b Switching Time Waveforms

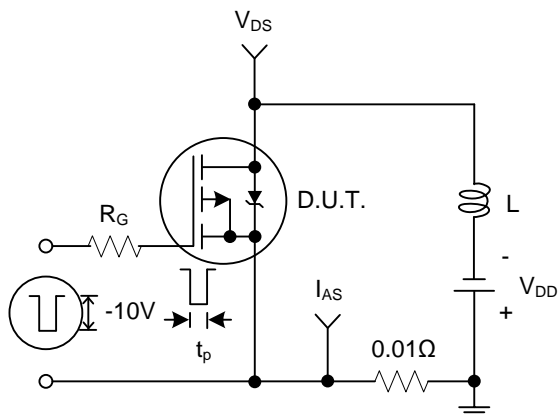

Fig. 2a Unclamped Inductive Test Circuit

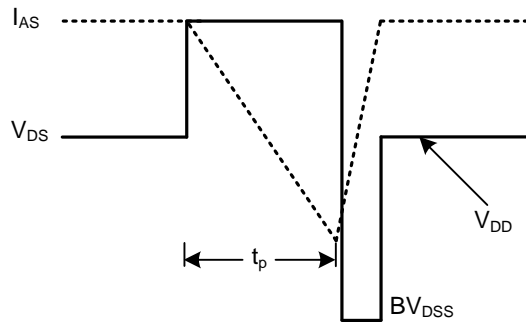

Fig. 2b Unclamped Inductive Waveforms

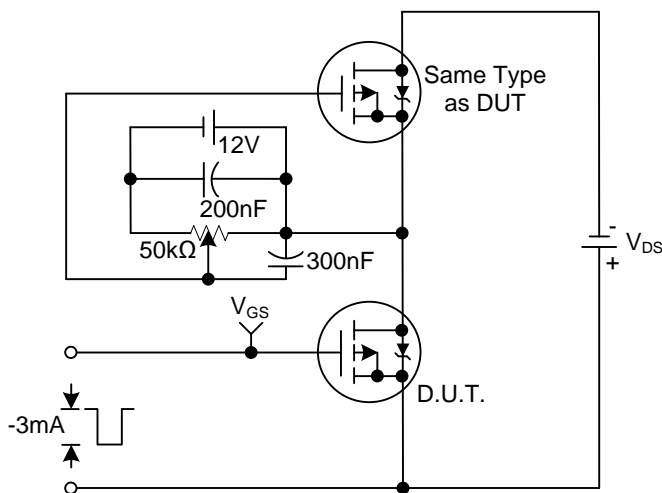

Fig.3a Gate Charge Test Circuit

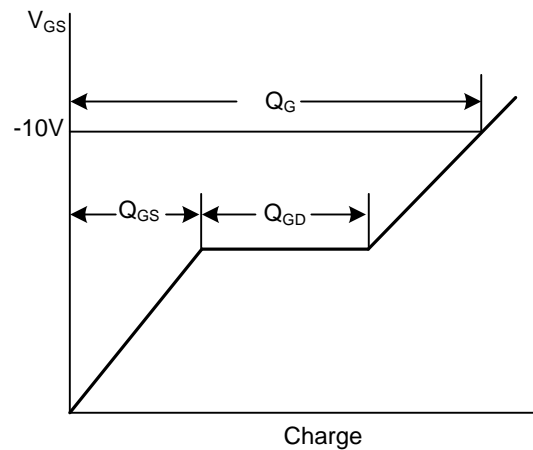
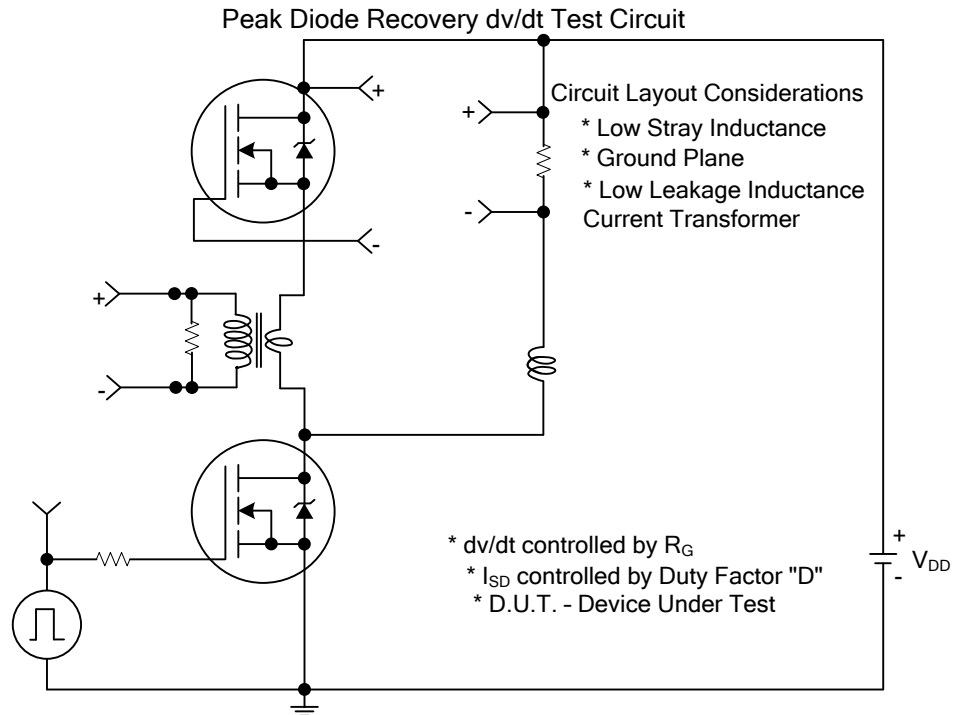
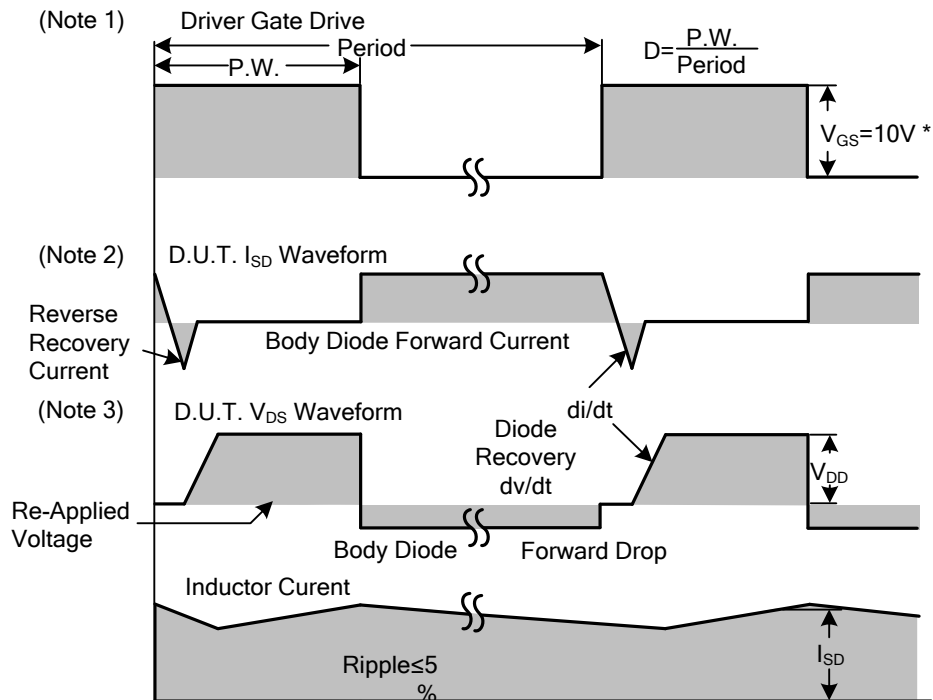

Fig. 3b Gate Charge Waveform

TEST CIRCUITS AND WAVEFORMS



* Reverse Polarity for P-Channel
 ** Use P-Channel Driver for P-Channel Measurements



*** $V_{GS} = 5V$ for Logic Level and 3V Drive Devices

For N and P Channel Power MOSFET

- Notes: 1. Repetitive rating; pulse width limited by max. junction temperature.
 2. $V_{DD} = -25V$, starting $T_J = 25^\circ C$, $L = 2.7mH$, $R_G = 25\Omega$, $I_{AS} = -12A$. (See Figure 2)
 3. $I_{SD} \leq -12A$, $di/dt \leq 200A/\mu s$, $V_{DD} \leq BV_{DSS}$, $T_J \leq 175^\circ C$

TYPICAL CHARACTERISTICS

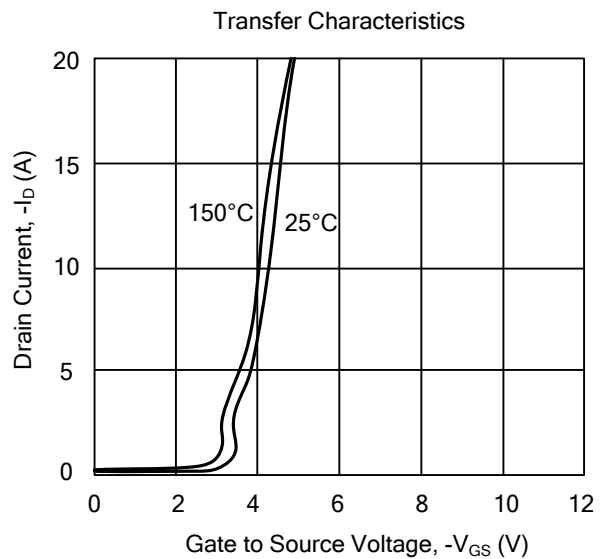
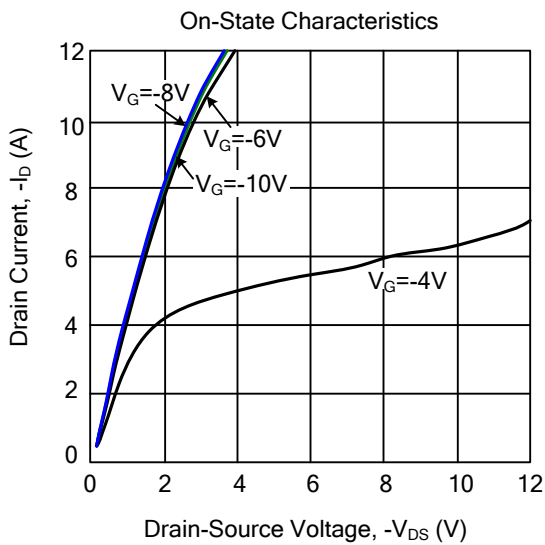
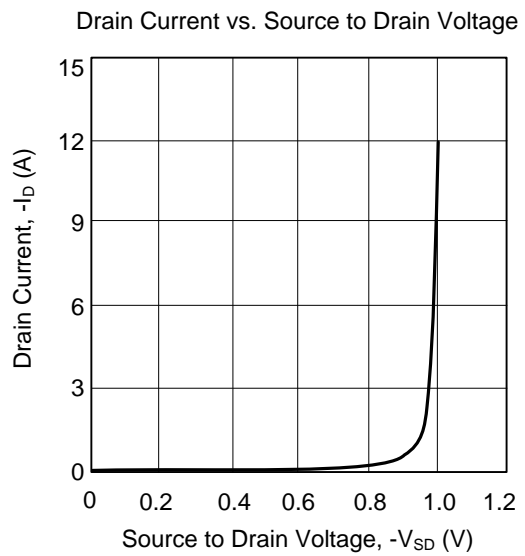
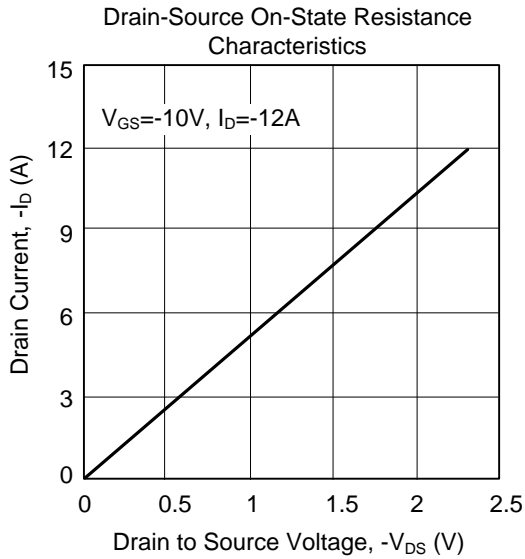
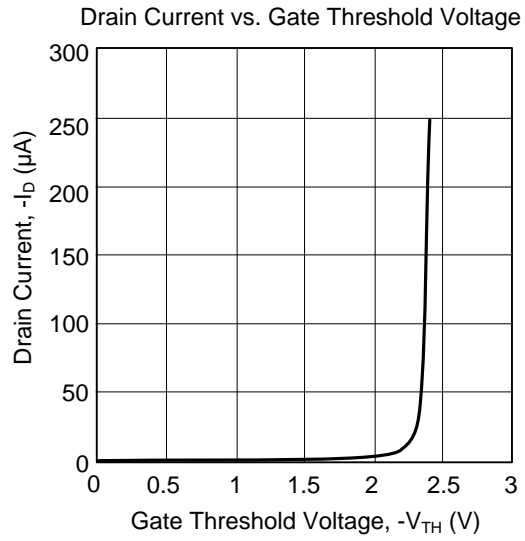
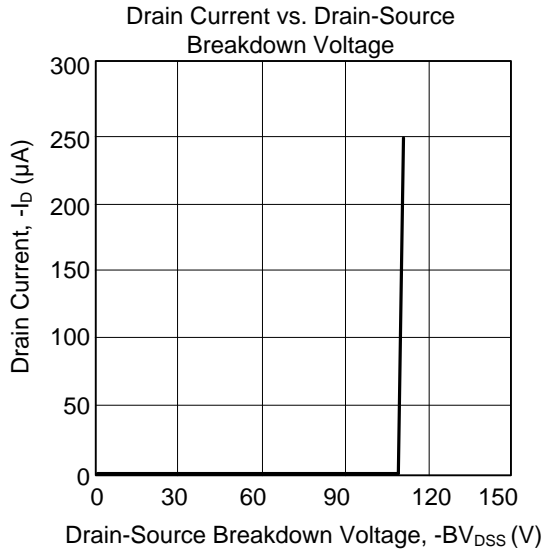

TYPICAL CHARACTERISTICS

Safe Operating Area

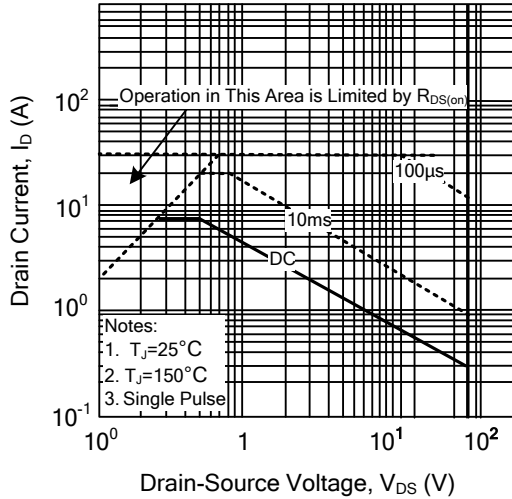

Transient Thermal Response Curve

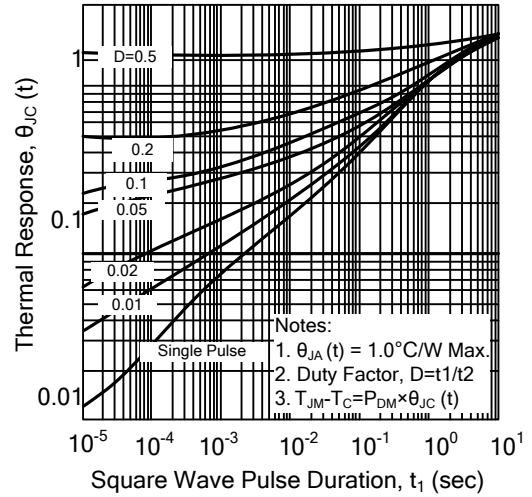

UTC assumes no responsibility for equipment failures that result from using products at values that exceed, even momentarily, rated values (such as maximum ratings, operating condition ranges, or other parameters) listed in products specifications of any and all UTC products described or contained herein. UTC products are not designed for use in life support appliances, devices or systems where malfunction of these products can be reasonably expected to result in personal injury. Reproduction in whole or in part is prohibited without the prior written consent of the copyright owner. UTC reserves the right to make changes to information published in this document, including without limitation specifications and product descriptions, at any time and without notice. This document supersedes and replaces all information supplied prior to the publication hereof.