

PROPRIETARY AND CONFIDENTIAL.  
 THE INFORMATION CONTAINED IN THIS DRAWING IS THE SOLE PROPERTY OF HTP ASIA TECHNOLOGY CO., LTD. .  
 ANY REPRODUCTION IN PART OR AS A WHOLE WITHOUT THE WRITTEN PERMISSION OF HTP ASIA TECHNOLOGY CO., LTD. IS PROHIBITED.

RoHS

IP66

REV	DESCRIPTION	DATE
A	ISSUE	APR/01/2014
B	Change gasket & packing way.	APR/15/2020

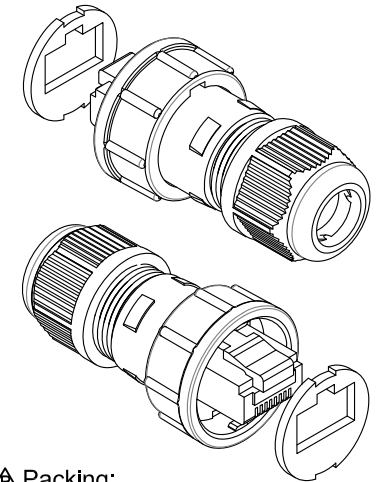
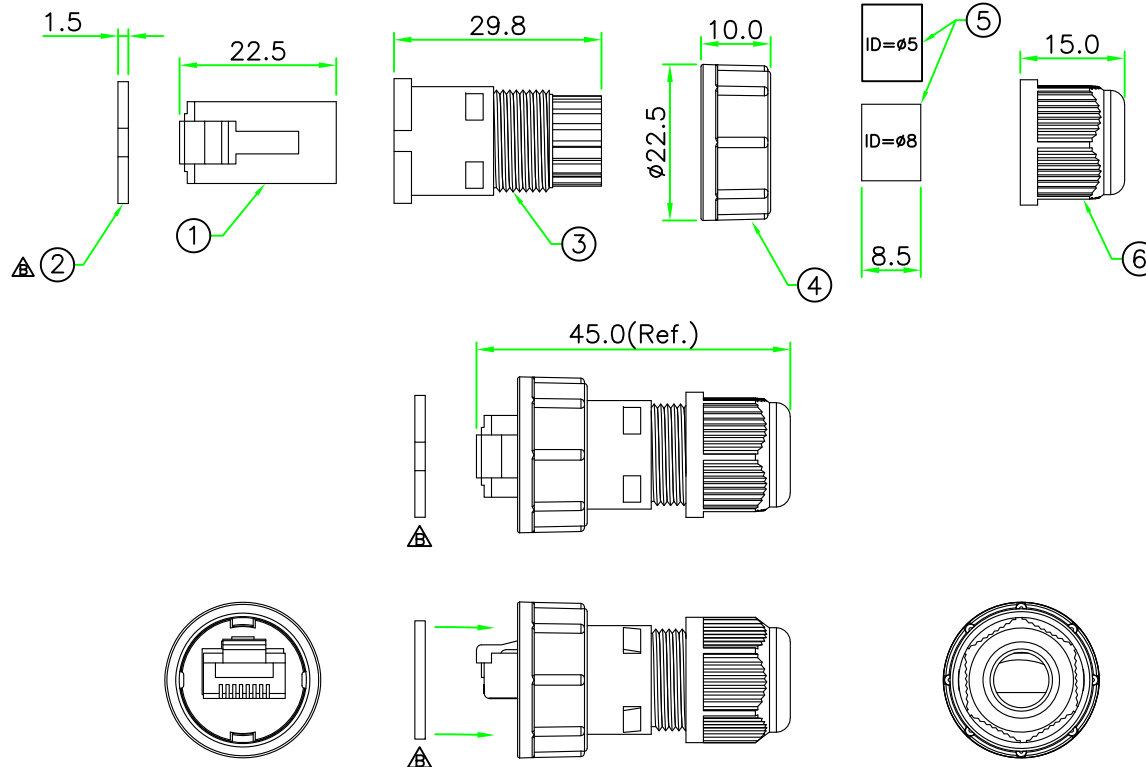

▲ Packing:

#2 Zipper PE Bag.

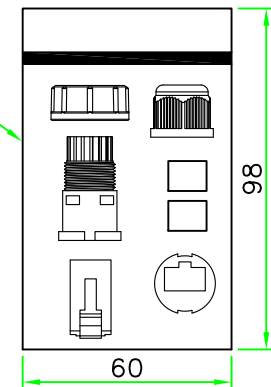

Notes:

Paste gasket up after RJ45 plug insert in position.  
 (RJ45 plug 插入後再黏貼上墊片)

原型號為:RJ45C-L108SAS

No.	PART NAME	DESCRIPTION	COLOR	Q'TY	REMARKS
6	SCREW	NYLON.	BLACK	1	70-135
5	SEAL	EPDM. for cable OD: 3~5mm & 5~8mm.	BLACK	2	71-135
4	SCREW NUT	SCREW NUT, NYLON+GF.	BLACK	1	
3	SLEEVE	CABLE SLEEVE, NYLON.	BLACK	1	69-135-N2
2	GASKET ▲	NBR.	BLACK	1	GSL-1815-NK03
1	RJ-45 PLUG	RJ-45 8P8C SHIELDED PLUG.		1	

<b>HOLIN</b> ® HTP ASIA TECHNOLOGY CO., LTD. 禾凌科技股份有限公司	
UNIT: mm SCALE 1:1 UNLESS OTHERWISE SPECIFIED TOLERANCES: X ±0.25 XX ±0.1 XXX ±0.05 ANGLE ±1° REV. B SHEET 1/2	TITLE : RJ45 PLUG C SIZE LOCK TYPE FIELD INSTALLABLE PLUG P/N: RJ45C-L4SAS DR. JAMES CH. ERIC DWG.NO: RJ45C-L4SAS AP.

# Installation Guide of RJ45 C-size Field Attachable Connector | RJ45 C-size 組裝式安裝說明

REV	DESCRIPTION	DATE
A	ISSUE	APR/01/2014
B	Change gasket & packing way.	APR/15/2020

Step 1: Pass the cable through the components 6.5.4.3 in sequence.  
 步驟 1: 將線材依序穿過部件 6, 5, 4, 3。

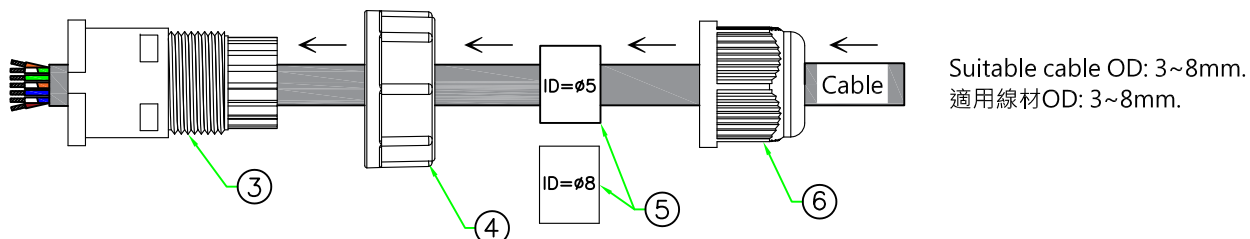

Step 2: Crimp the RJ45 plug onto the stripped cable, insert RJ45 plug into component 3.  
 步驟 2: 線材壓接RJ45後，將RJ45推回部件3。

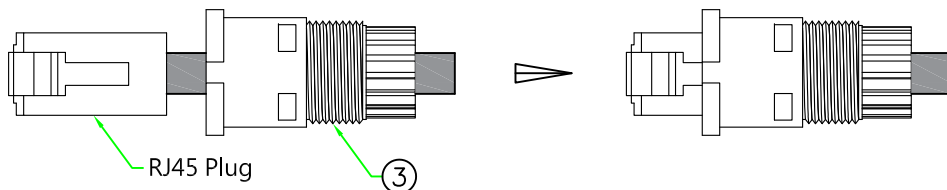

Step 3: Remove paper of adhesive of Gasket (component 2), stick the Gasket to the plane of the component 3.  
 步驟 3: 撕去墊片之背膠膜後(部件2)·貼回連接器平面。

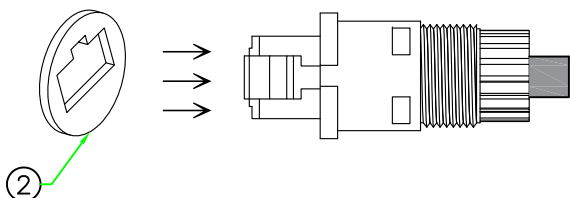

Step 4: Assemble components 4.5.6 in sequence.  
 步驟 4: 將部件4, 5, 6 依序組裝。

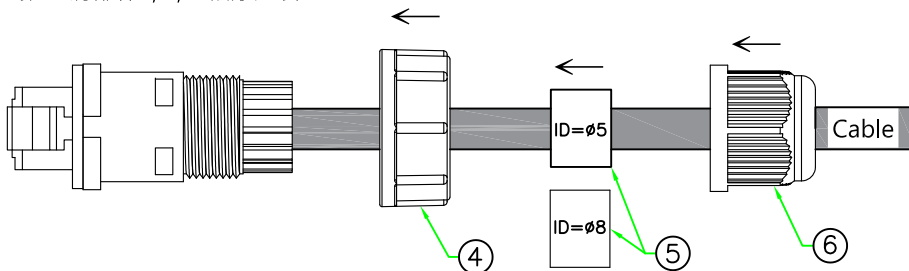

<b>HOLIN<sup>®</sup></b> HTP ASIA TECHNOLOGY CO., LTD. 禾凌科技股份有限公司			
	UNIT: mm	TITLE : RJ45 PLUG C SIZE LOCK TYPE FIELD INSTALLABLE PLUG	
SCALE	1:1		
UNLESS OTHERWISE SPECIFIED TOLERANCES:		P/N:	DR. JAMES
x	±0.25	xx	±0.1
xxx	±0.05	ANGLE	±1°
REV.	SHEET	DWG.NO:	AP.
B	2/2	RJ45C-L4SAS	