

SPECIFICATION FOR APPROVAL

承 認 書

Description : Electret Condenser Microphone

Kingstate Part No. : KEAG1500L

Customer's Model No. : _____

Specification No. : DDM-8883

Number Of The Edition : 1.1

CUSTOMER'S APPROVED SIGNATURE		

志豐電子股份有限公司 KINGSTATE ELECTRONICS CORP.



Address :10F, No. 69-11, Sec. 2, Chung Cheng E. Rd., Tamshui County, Taipei Hsien, Taiwan, R.O.C.

International sales dept.: TEL:886-2-2809-5651 FAX:886-2-2809-7151

Domestic sales dept.: TEL:886-2-2809-0668 FAX:886-2-28096748

<http://www.kingstate.com.tw>

Approved by	Checked by	Issued by

A. SCOPE 範疇

This specification applies electret condenser microphone, **KEAG1500L**

此規格書適用於電容式麥克風 **KEAG1500L**

B. SPECIFICATION 規格

No.	Item	Symbol	Unit	Specification	Condition
1	Directivity 方向性			Uni-Directional 單指向	
2	Sensitivity 靈敏度	S	dB	-42± 3	f=1KHz, 1Pa 0dB=1V/Pa
3	Standard operating voltage 標準操作電壓	Vs	V D.C.	2	
4	Output impedance 輸出阻抗	Zout	Ω	2.2	f=1KHz, 1Pa
5	Max operating voltage 最大操作電壓		V D.C.	10	
6	Sensitivity reduction 減電壓靈敏度	$\Delta S-Vs$	dB	-3	f=1KHz, 1Pa Vs=3.0V D.C. to 2.0V D.C.
7	Frequency 頻率	f	Hz	100 ~ 10,000	
8	Max. current consumption 最大耗電流	IDSS	mA	0.5	Vs=3.0V D.C. RL=2.2KΩ
9	Signal to noise ration 訊號對雜音比	S/N	dB	60	f=1KHz, 1Pa A weighted
10	Operation temp. 操作溫度		°C	-20 ~ +70	
11	Storage temp. 儲存溫度		°C	-20 ~ +70	
12	Dimension 尺寸		mm		See appearance drawing 請參照外觀尺寸圖
13	Weight (MAX) 重量		gram	20	
14	Material 材質				
15	Terminal 端子			Wire type	See appearance drawing 請參照外觀尺寸圖 (Hand Soldering Only)
16	Environmental Protection Regulation 環保法規			RoHS 2.0	

We use "Pascal(Pa)" indication of sensitivity as per the recommendation of I.E.C.(International Electro technical Commission).

The Sensitivity of "Pa" will increase 20dB comparing with "ubar" indication.

Example: -60dB(0dB=1V/ubar) = -40dB(1V/Pa)

依 I.E.C.(國際電子協會)建議,以"Pa"為靈敏度標示單位比"ubar" 靈敏度標示單位增加 20dB

例如: -60dB(0dB=1V/ubar) = -40dB(1V/Pa)

C. TYPICAL FREQUENCY RESPONSE CURVE 頻率響應曲線

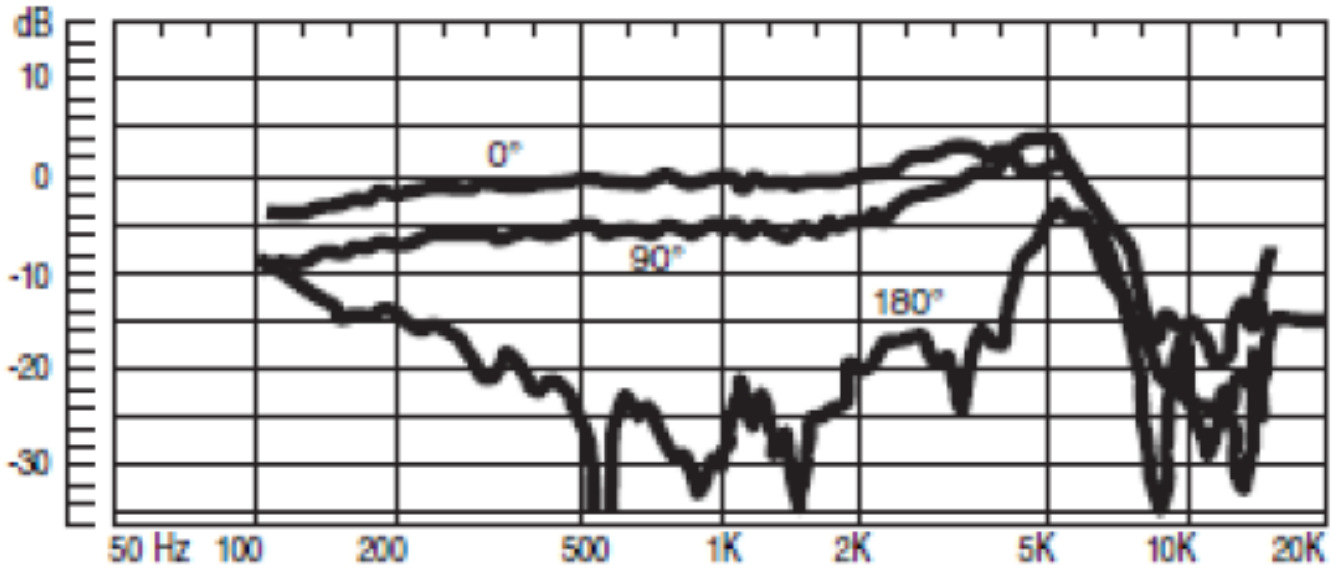

Frequency Response

D. APPEARANCE DRAWING

外觀尺寸圖

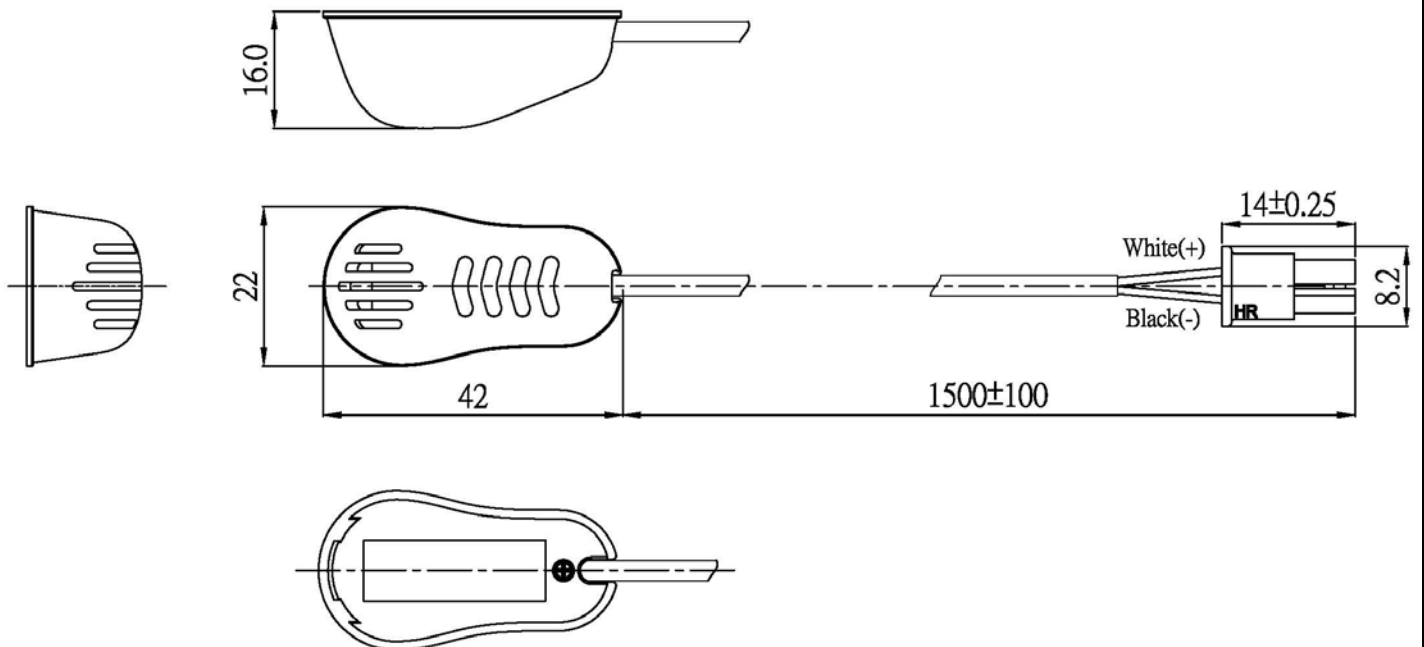

端子型號：C3030HF-2P 線材型號：UL1533#26屏蔽線

E. MEASUREMENT CIRCUIT 測量線路

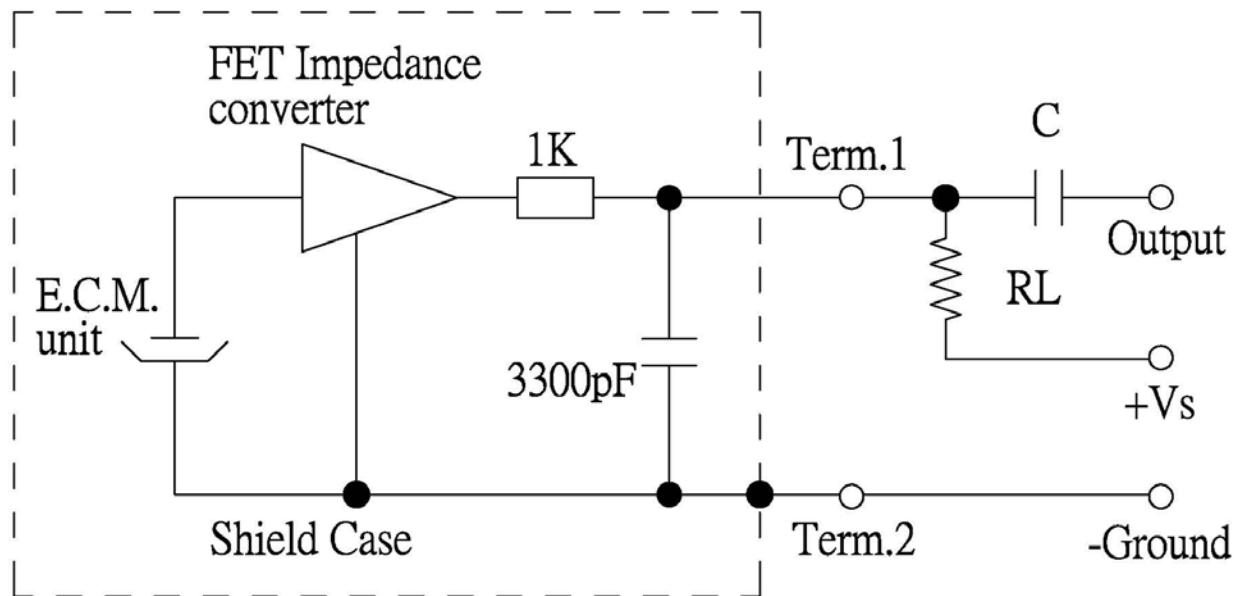

Schematic Diagram

F. MECHANICAL CHARACTERISTICS 機械特性

No.	Item	Test condition	Evaluation standard
1	Soldering Heat Resistance 焊錫耐熱性	Soldering iron of $+270\pm 5^{\circ}\text{C}$ should be placed on the terminal for 2 ± 0.5 seconds. 端子部份置於 $+270\pm 5^{\circ}\text{C}$ 烙鐵上 2 ± 0.5 秒。	No interference in operation 操作無任何不良
2	PCB Wire Pull Strength PCB 線材拉力	The pull force shall be applied to double lead wire : Horizontal 4.9N(0.5kg) for 30 seconds. 雙線材水平方向施以 4.9N(0.5kg) 的力量, 30 秒。	No damage and cutting off. 不鬆動, 不脫落。
3	Vibration Test 振動測試	The part shall be measured after being applied vibration of amplitude of 1.5mm with 10 to 55hz band of vibration frequency to each of 3 per-pendicular directions for 2 hours. 振動週波數 10~55HZ、全振幅 1.5mm 於 X.Y.Z 3 個方向, 各 2 小時。	After any tests, the sensitivity to be within $\pm 3\text{dB}$ 測試其靈敏度須與原測試值的差異不超過 $\pm 3\text{dB}$ 。
4	Drop Test 落下測試	The part unit without packaged must be subjected to each 3 drops at three axes from the height of 1 meter to 20 mm thick wooden board. 未包裝麥克風單體從 1 公尺高處, X.Y.Z.3 個方向, 各 3 回, 落於 20mm 厚木板上。	

G. ENVIRONMENTAL TEST 環境試驗

No.	Item	Test conditions	Evaluation standard
1	High temp. test 高溫測試	After being placed in a chamber at +70°C for 72 hours. 置於+70°C環境中 72 小時	
2	Low temp. test 低溫測試	After being placed in a chamber at -20°C for 72 hours. 置於-20°C環境中 72 小時	
3	Humidity test 相對濕度測試	After being placed in a chamber at +40°C and 90±5% relative humidity for 240 hours. 置於+40°C, 相對濕度 90±5%環境中 240 小時	
4	Temp. cycle test 溫度循環測試	<p>The part shall be subjected to 10 cycles. One cycle shall consist of:</p> <p>單體承受溫度循環測試 10 次,其循環內容如圖示:</p>	

TEST CONDITION.

Standard Test Condition	: a) Temperature : +5 ~ +35°C	b) Humidity : 45-85%	c) Pressure : 860-1060mbar
一般測試條件	: a) 溫度 : +5 ~ +35°C	b) 濕度 : 45-85%	c) 氣壓 : 860-1060mbar
Judgement Test Condition	: a) Temperature : +25 ± 2°C	b) Humidity : 60-70%	c) Pressure : 860-1060mbar
標準測試條件	: a) 溫度 : +25 ± 2°C	b) 濕度 : 60-70%	c) 氣壓 : 860-1060mbar

H. PACKING STANDARD 包裝規格

Each minimum package unit of products shall be in a carton box and it shall be clearly marked with Part Number, quantity and outgoing inspection number. There shall be no mechanical damage on products during transportation and/or in storage.

外箱須標示最小包裝單位, 並註明產品型號、數量及檢驗批號., 必須是物品儲藏或運輸過程中可防止造成損傷的包裝