

- The company reserves the right to the interpretation of all content in the manual, Please feel free to contact us for more details
- Our technical staff shall provide best service to you sincerely, if the pictures is different from the real objects, Please refer to real object
- Unauthorized Use, Prohibited to copy all or part of the information
- There's no prior notice if any change. Sincerely hope that this manual can bring convenience to you
- Products: research and development, Continuous innovation of technology.....

(C) HUANGSHAN MJER ELECTRONICS CO.,LTD. all Rights Reserved. Cherish Resources, Be Kind To The Environment



No.75 Xinguang Road,
Liushi Town, Yueqing City,
Zhejiang Province, China.



+86-577-61771067



+86-577-62628176



www.hsmjer.com



mjer-sale-so2@hsmjer.com



MJER[®]

Advanced automatic production equipment, precise pipelining assembly,
First level quality guaranteed, technical expert directly take part in the production,
Which ensure the stability and reliability of the products without any defects,
No matter how this world changes, excelsior spirits of MJER staff will be consistent.

PROFESSIONAL MANUFACTURING

RoHS ISO9001 CE CCC

HUANGSHAN MJER ELECTRONICS CO.,LTD.
HUANGSHAN MJER IMP.&EXP.CO.,LTD.

ENTERPRISE INTRODUCTION

Huangshan MJER Electronics Co., Ltd is a professional manufacturer for semiconductors, with our head office in Huangshan. The headquarters is located in Mount Huangshan, the branch is located in the capital of Chinese electrical appliances – Liushi, Wenzhou, with convenient transportation which is close to Wenzhou airport, railway station, and port. After years of innovation and hard work, our company strictly follows the international standards for scientific research, development, design, and production. We pay great attentions to every detailed factor and insist 'keep innovation and pursuit for technological progress' as our principle. We own a professional R&D team with experienced engineers and advanced producing and testing equipments. We keep learning updated new technology abroad and improving our quality, After several years of developing, we have successfully established a multi-level marketing network and the products are sold widely around the world.

The products from our company are strictly under the national standard. We can mainly manufacture: Schottky/fast recovery diode, fast thyristor module, rectifier module, common thyristor module, thyristor, rectifier tube mixing module, non insulated thyristor, ordinary rectifier module, non insulated thyristor module, non insulated rectifier module, single / three phase rectifier module, bridge rectifier, solid state relay, ZP rectifier tube, KP thyristor, KS bidirectional thyristor, ZX rotating rectifier tube, KX rotating thyristor, SS water cooling radiator, SF air cooling radiator, shunt, core, silicon rectifier, power semiconductor module, the power regulator, motor soft starter (cabinet), power rectifier assembly series and so on.

All the employees from MJER follow to "virtuous talents, integrity work, scientific and technological innovation," people-oriented and 'customer focused' as our philosophy to innovate and develop. We offer first class quality, reasonable price and best service after sale to satisfy the customers for bilingual profits. Our ability is limited, but our creation is unlimited. We will keep working on innovation and constantly surpassing to optimize our own enterprise images. We are willing to establish our relationships with both new and old customers all over the world.

RoHS ISO9001 CE CCC



PRODUCT CATALOGUE

Photovoltaic anti diode

02 Photovoltaic Anti Diode

Power Modules

04 Thyristor Module
 05 Diode Module
 06 Thyristor-diode Module
 07 One Unite Module
 08 Fast Turn-off Thyristor/fast Rectifier Diode Module
 09 Thyristor/diode Module(non-isolated Type)
 10 Single/three Phases Rectifying Bridge Module
 11 Single Phase.3phase Full Control/half Control Thyristor Bridge Module
 12 Schottky/super Fast Recovery Diode Module
 13 Outline Drawing

Solid State Relay

16 Schottky/super Fast Recovery Diode Module
 17 Single Phase SSR
 18 H3 60T02000A Industrial Grade SSR
 19 GJX10 T0 400A Three Phase SSR

Intelligent Module

20 DTY Single-phase\sty Three Phase AC Phase Shift Voltage Adjusting Interlligent Module
 21 IGBT Module

Bridge Rectifier

22 Bridge Rectifiers

Stud Version Semiconductor

23 Standard Recovery Diode (Stud Version)
 24 Fast Recovery Diode (Stud Version)
 25 Phase Control Thyristor (Stud Version)
 26 Triac Thyristor (Stud Version)
 27 Russia Type Diode (Stud Version)
 29 Russia Type Thyristor (Stud Version)
 31 SEMIKRON Type Semicondctor (Stud Version)
 33 Chinese Type Semiconductor (Stud Version')

Capsule Verston Semiconductor

35 Standard Recovery Diode (Capsule Version)
 36 Phase Control Thyristor (Capsule Version)
 37 Triac Thyristor (Capsule Version)
 38 High Frequency Thyristor (Capsule Version)
 39 Triac Thyristor (Capsule Version)
 40 Russia Type Semiconductor (capsule Version)

Heatsink

43 Installation And Selection Of Radiator
 44 Power Modula Version Heatsink
 45 Stud Version Heatsink
 46 Water-cool Heat Sink
 47 Chinese Standard Capsule Version Heatsink
 48 Power Semiconductor Parts

Welding Machine Device

49 Welding Rectifier Assembly
 51 press-fit diode series

Relay Series

52 General Relay/High Power Relay
 53 Time relay/Relay socket



Summary

Conditions Of Use And Notice:

- The use of the environment should be no violent vibration and impact, environmental medium impurities and atmosphere without corrosion and damage to the insulation of.
- Module die junction temperature: -40~150°C diode. environmental temperature not higher than 40°C ;environmental humidity is less than 86% Module.
- Before use must install radiator,heat can be forced by natural cooling,cold when applied to the actual load currant is more than 40A devices generally need to choose a forcedair cooling system Forced cold,wind speed should be greater than 6m/s.
- Equipment up and running 30 minutes-60 minutes. reached thermal equilibrium We require anti diades mounted radiator temperature less than 50°C the highest effective When the radiator is the work environment at the temperature of 25°C. , the temperature of the radiator should be less than 75 DEG C; if the environment temperature At 45°C ,The temperature of the radiator should be less than 95°C .
- Must ensure that the control of air and the cabinet body circulation flow of air in the cabinet When the anti reverse diode module installed in the control cabinet, control cabinet must be installed on the top of the 2-3 platrom to the cabinet body ventilation of the axial flow fan (hot air is rising. conducive to heat dissipation). and control cabinet Near the boflom around the need to set the shutter.

Installation Notes:

- because GJM series photovoltaic anti diode module is insulated type (i.e. module wiring column on the insulation between the copperplate is greater than the 3.1KV value),so you can put a plurality of modules are installed in the same radiator,or device grounding shell.
- radiator mounting surface should be flat, smooth, no scratches, bump and sund ries. Tha radiator surfaca finish should be less than 10 μM. Aodule is installed in the radiator,between thier contact surface thermal grease coated with a thin layer of. Grease, with fine sandpaper to heatThe contact surface of the oxicie layer is removed, and then ethanol wipa them surface. make good contact, in order to reduce the thermal resistance. Module is fastened to the surface of the radiator, using M5 Or M6 screw and spring washer, and shall ba recovera ble by tha 4N M torque fastening screws on the modu/e main electrode attachment Copper bar, and a contact surface smooth, make good cor,tact. Module 3 hours later, all the screws to tighten again again. Select the user selection module radiator radiator, must consider the following factors:
- The size of the module working currentt to determine the required radiator area;
- The use of the environment, we can determine what cooling way -- natural cooling, forcad air cooling or water cooling,
- he device shape, volume, to the radiator resarved space size, which can be determined by what the shapa of the radiator,

Circuit Configurations



Specification

Type	I _F (AV)	VRRM	VTM@IFM		IRRm	IF(RMS)	IFSM	Rjc	Tjm	Viso	Outline
	A	V	V	A	mA	A	A×100	°C/W	°C	V(AC)	
MD/MDK25A	25	1600-2500	0.9	80	8	41	0.65	1.300	13.00	2500	4
MD/MDK55A	55	1600-3000	0.9	170	8	86	1.30	0.700	0.700	2500	4
MD/MDK90A	90	1600-3000	0.9	270	8	141	2.30	0.470	0.470	2500	4
MD/MDK110A	110	1600-3000	0.9	330	8	173	2.60	0.350	0.350	2500	4
MD/MDK130A	130	1600-3000	1.1	410	12	212	3.90	0.310	0.310	2500	5
MD/MDK160A	160	1600-3000	1.1	480	12	251	6.00	0.230	0.230	2500	5
MD/MDK200A	200	1600-3500	1.1	600	12	214	8.00	0.210	0.210	2500	7
MD/MDK250A	250	1600-3500	1.38	750	20	393	11.00	0.140	0.140	2500	7
MD/MDK300A	300	1600-3500	1.38	900	20	471	12.5	0.130	0.130	2500	7
MD/MDK350A	350	1600-3500	1.38	1050	30	550	15.0	0.110	0.110	2500	8
MD/MDK500A	500	1600-3500	1.38	1500	40	785	21.0	0.90	0.90	2500	8
MD/MDK600A	600	1600-3500	1.38	1500	40	785	12.0	0.130	0.130	2500	9
MD/MDK800A	800	1600-3500	1.45	1800	40	942	15.0	0.110	0.110	2500	11
MD/MDK1000A	1000	1600-3500	1.45	2400	40	1250	18.0	0.080	0.080	2500	12

Photovoltaic Anti Diode

Conditions Of Use And Notice:

- Chips are electrically insulated from bottom plate.
- Seal in compliance with international standard Pressure type.
- Excellent power/volume ratio.
- Maximum junction temperature up to 150°C , Low forward voltage drop.

Application:

- PV junction box.
- PV DC cabinet.
- PV D C system.

technical parameter

Symbol	Parameters	Test Conditions	Tj(°C)	Parameter Values			Company
				Lea	Typ	Max	
I _F (AV)	Forward mean current	180° Sinusoidal half wave,50Hz, Single side heat dissipation,T _c =100°C	150	600		85	A
I _F (MS)	Square root current		150			86	A
V _M	Reverse repeat peak voltage	V _M TP=10ms,V _{SM} =V _M 200V	150			1800	V
I _M	Reverse repeat peak current	V _M =V _M	150			8	MA
I _{FSM}	Forward unrepeatd surge current					1.30	A
i ² t	Surge current square time product	10ms Wide bottom,Sinusoidal half wave,V=0.6V _M I _{FM} =170A	150			8.6	A2S103
V _F	The threshold voltage		25			0.80	V
R _F	Slope resistance					3.47	MΩ
V _{FM}	Forward peak voltage					1.5	V
th(jc)	Thermal impedance (junction to radiator)	180° Sinusoidal half wave, Single side heat dissipation				0.700	°C/W
th(ch)	Thermal impedance (junction to radiator)	180° Sinusoidal half wave, Single side heat dissipation				0.2	°C/W
V _{iso}	Insulation voltage	50Hz,M.S.T=1MIN,I iso 1MA(MAX)		2500	2500		V
V _M	Mounting torque (M5)					4	m
	Mounting torque (M6)					6	m
T _{stg}	Storage temperature			40		125	°C
W _T	Quality	Shape 101F				115	g
Size	Box size						mm

Characteristics Curve

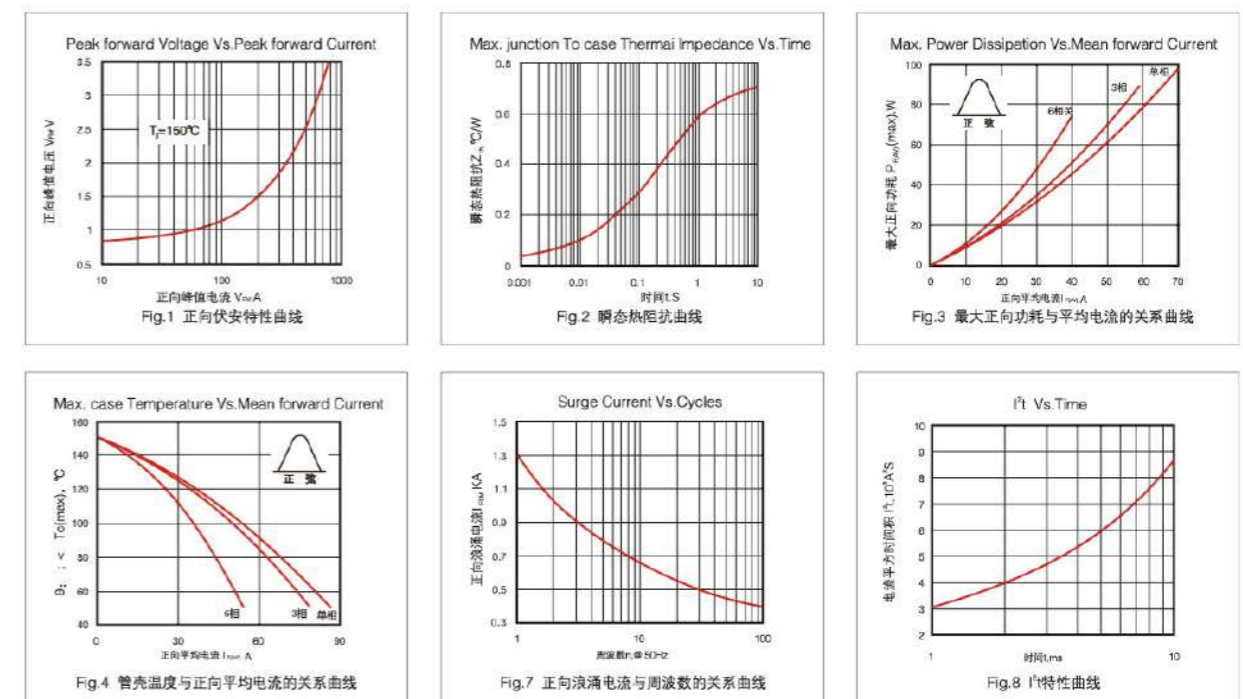



Thyristor Module(MTC,MTX,MTA,MTK,MT,SKKT)

Features:

- Chips are electrically insulated from bottom plate.
- Sealin com pliance with international standard. Pressure type excellent temperature characteristics and power cycling capa bility.
- 350A below modules are forced air cooling ; 400A above modules can select air cooling or water cooling.

Application:

- AC, DC motor control, Different kind of rectifying power supply.
- Industrial heating and control, Light adjustment, Non-contact switch
- Motor softstarter, Static reactive power compensation.
- Welding equipment, Frequency transformer, UPS.
- Battery charging and discharging.

Cicrcuit Configurations

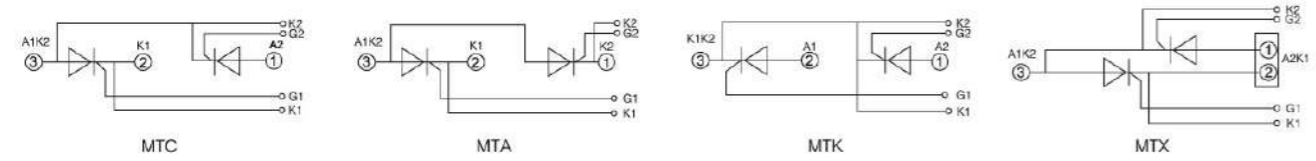

Specification

Type	IT(AV)	VRRM	VTM@IFM		IDRM	IRRM	IGT	IGT	IH	dv/dt	di/dt	ITSM	Rjc	Tjm	Viso	Outline
	A	V	V	A	mA	mA	V	V	mA	V/ μ S	A/ μ S	A $\times 10^3$	$^{\circ}$ C /w	$^{\circ}$ C	V(AC)	
MTx25A	25	500-2500	1.69	80	8	100	2.5	100	800	50	0.55	0.950	125	2500	2/4	
MTx55A	55	500-2500	1.50	170	8	100	2.5	100	800	50	1.25	0.530	125	2500	2/4	
MTx90A	90	500-2500	1.94	270	15	100	2.5	100	800	100	2.00	0.280	125	2500	2/4	
MTx110A	110	500-2500	1.90	330	20	100	2.5	100	800	100	2.40	0.250	125	2500	2/4	
MTx130A	130	500-2500	1.96	410	25	150	2.5	100	800	100	3.80	0.200	125	2500	3/5	
MTx160A	160	500-2500	1.90	480	25	150	2.5	100	800	100	5.40	0.170	125	2500	3/5	
MTx220A	200	500-2500	1.90	600	30	180	2.5	100	800	100	7.20	0.140	125	2500	3/9	
MTx250A	250	500-2500	1.73	750	30	180	2.5	100	800	100	8.50	0.120	125	2500	3/9	
MTx300A	300	500-2500	1.58	900	40	80	2.5	100	800	100	9.30	0.100	125	2500	8/9	
MTx350A	350	500-2500	1.45	1050	40	180	2.5	100	800	100	11.00	0.090	125	2500	10	
MTx500A	500	500-2500	1.44	1500	40	200	3.0	100	800	100	16.0	0.065	125	2500	10	
MTx600A	600	500-2500	1.90	1800	40	200	3.0	100	800	100	11.0	0.087	125	2500	10/11	
MTx800A	800	500-2500	1.90	2400	40	200	3.0	100	800	100	13.0	0.73	125	2500	15	
MTx500A*	500	500-2500	1.95	1500	40	200	3.0	100	800	100	16.0	0.054	125	2500	14	
MTx600A*	600	500-2500	1.95	1800	40	200	3.0	100	800	100	16.0	0.054	125	2500	15	
MTx800A*	800	500-2500	1.95	2400	40	200	3.0	100	800	100	16.0	0.054	125	2500	15	
MTx1000A*	1000	500-2500	1.95	3000	40	200	3.0	100	800	100	16.0	0.054	125	2500	16	

Note:*Water-Cooling



Diode Module(MDC,MDK,MDA,MDX,MD,SKKD)

Features

- The chips are electrically insulated from bottom plate 2500V AC voltage,
- Packaged as perinternational standard.
- Complete pressure connection structure , with excellent temperature characteristicsand power cycling capacity.
- Forced air cooling for modules below 400A and air cooling or water cooling formodules above 500A.

Application

- DC power supplies of appliances and devices.
- AC&DC motor control Soft starting for motors.
- Various rectifying power supplies.
- Electric welders , Frequency transformers.
- Battery charging and discharging.

Cicrcuit Configurations

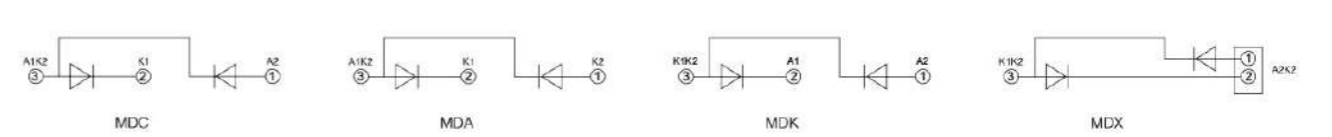

Specification

Type	IT(AV)	VRRM	VTM@IFM		IRRM	IF(RMS)	IFSM	Rjc	Tjm	Viso	Outline
	A	V	V	A	mA	A	A $\times 100$	$^{\circ}$ C /w	$^{\circ}$ C	V(AC)	
MDx25A	25	500-2500	1.65	8	41	0.65	1.300	1.300	1.300	2500	2/4
MDx55A	55	500-2500	1.45	8	86	1.30	0.700	0.700	0.700	2500	2/4
MDx90A	90	500-2500	1.33	8	141	2.30	0.470	0.470	0.470	2500	2/4
MDx110A	110	500-2500	1.45	8	173	2.60	0.350	0.350	0.350	2500	2/4
MDx130A	130	500-2500	1.38	12	212	3.90	0.310	0.310	0.310	2500	5/6
MDx160A	160	500-2500	1.56	12	251	6.00	0.230	0.230	0.230	2500	5/6
MDx200A	200	500-2500	1.38	12	314	8.00	0.210	0.210	0.210	2500	5/9
MDx250A	250	500-2500	1.43	20	393	11.0	0.140	0.140	0.140	2500	7/9
MDx300A	300	500-2500	1.35	20	471	12.5	0.130	0.130	0.130	2500	7/9
MDx350A	350	500-2500	1.50	30	550	15.0	0.110	0.110	0.110	2500	8/9
MDx500A	500	500-2500	1.35	40	785	21.0	0.90	0.90	0.90	2500	10
MDx600A	600	500-2500	1.65	40	785	12.0	0.130	0.130	0.130	2500	10
MDx800A	800	500-2500	1.65	40	942	15.0	0.110	0.110	0.110	2500	11
MDx1000A	1000	500-2500	1.70	40	1256	18.0	0.080	0.080	0.080	250	12
MDx500A*	500	500-2500	1.35	40	785	21.0	0.90	0.90	0.90	2500	13
MDx600A*	600	500-2500	1.65	40	785	12.0	0.130	0.130	0.130	2500	14
MDx800A*	800	500-2500	1.65	40	942	15.0	0.110	0.110	0.110	2500	14
MDx1000A*	1000	500-2500	1.70	40	1256	18.0	0.080	0.080	0.080	2500	15

Note:*Water-Cooling



Thyristor/diode Module(MFC,MFA,MFK,MFX,SKKH)

Features:

- Chips are electrically insulated from bottom plate.
- Sealin compliance with international standard. Pressure type excellent temperature characteristics and power cycling capability.
- 350A below modules are forced air cooling ; 400A above modules can select air cooling or water cooling.

Application:

- AC, DC motor control, different kind of rectifying power supply.
- Industrial heating and control, Light adjustment, Non-contact switch
- Motor softstarter, Static reactive power compensation.
- Welding equipment, Frequency transformer, UPS.
- Battery charging and discharging.

Circuit Configurations

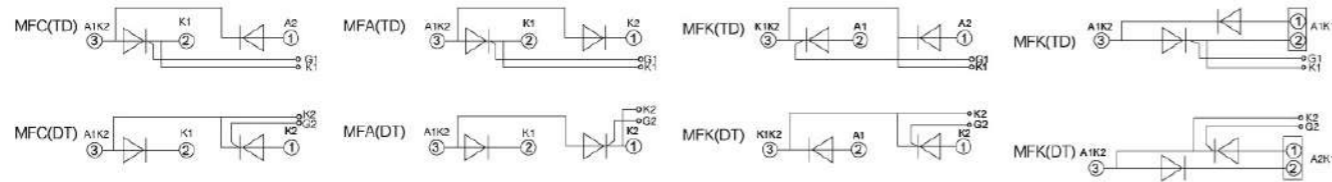

Specification

Type	IT(AV)	VRRM	VTM@IFM		IDRM	IRRM	IGT	IGT	IH	dv/dt	di/dt	ITSM	Rjc	Tjm	Viso	Outline
	A	V	V	A	mA	mA	V	V	mA	V/μS	A/μS	A×10 ³	°C/w	°C	V(AC)	
MF×25A	25	500-2500	1.69	80	8	100	2.5	100	800	50	0.55	0.950	125	2500	1/4	
MF×55A	55	500-2500	1.50	170	8	100	2.5	100	800	50	1.25	0.530	125	2500	1/4	
MF×90A	90	500-2500	1.94	270	15	100	2.5	100	800	100	2.00	0.280	125	2500	1/4	
MF×110A	110	500-2500	1.90	330	20	100	2.5	100	800	100	2.40	0.250	125	2500	3/4	
MF×130A	130	500-2500	1.96	410	25	150	2.5	100	800	100	3.80	0.200	125	2500	3/5	
MF×160A	160	500-2500	1.90	480	25	150	2.5	100	800	100	5.40	0.170	125	2500	3/5	
MF×220A	200	500-2500	1.90	600	30	180	2.5	100	800	100	7.20	0.140	125	2500	5/7	
MF×250A	250	500-2500	1.73	750	30	180	2.5	100	800	100	8.50	0.120	125	2500	5/7	
MF×300A	300	500-2500	1.58	900	40	80	2.5	100	800	100	9.30	0.100	125	2500	5/8	
MF×350A	350	500-2500	1.45	1050	40	180	2.5	100	800	100	11.00	0.090	125	2500	10	
MF×500A	500	500-2500	1.44	1500	40	200	3.0	100	800	100	16.0	0.065	125	2500	10	
MF×600A	600	500-2500	1.90	1800	40	200	3.0	100	800	100	11.0	0.087	125	2500	11	
MF×800A	800	500-2500	1.90	2400	40	200	3.0	100	800	100	13.0	0.73	125	2500	11	
MF×1000A	1000	500-2500	1.95	3000	40	200	3.0	100	800	10	16.0	0.054	125	2500	12	
MF×500A*	500	500-2500	1.44	1500	40	200	3.0	100	800	100	16.0	0.065	125	2500	14	
MF×600A*	600	500-2500	1.90	1800	40	200	3.0	100	800	100	11.0	0.087	125	2500	15	
MF×800A*	800	500-2500	1.90	2400	40	200	3.0	100	800	100	13.0	0.73	125	2500	15	
MF×1000A*	1000	500-2500	1.95	3000	40	200	3.0	100	800	100	16.0	0.054	125	2500	16	



One Unite Module

Features

- Base Chip insulation AC voltage 2500V.
- International standard packing.
- Excellent temperature feature.
- >300A could chose water-cool.
- Easy to install.

Application

- AC DC motor control.
- Motor soft start.
- Industry heat-up control.
- Rectification power supply.
- Welder.
- Frequency transformer.
- UPS power supply.
- Battery charge discharge.

Device Code

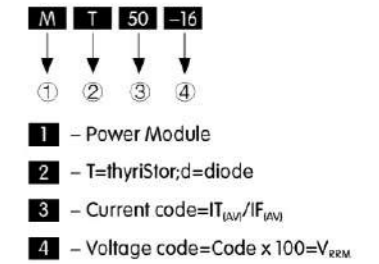

Explanation

- IGT, VGT, IH are all TA = 250°C test data, others are all TA = Tjm test data.
- $I_{2t} = I_{TSM} \times t_{w/2}; t_{w/2} =$ Half sine wave current, when at 50Hz.
 $I_{2t} = 0.005 I_{TSM} (A2S)$
- When at 60Hz, $I_{TSM}(8.3ms) = I_{TSM}(10ms) \times 1.066, m_j = T_{jm}$
 $I_{2t}(8.3ms) = I_{2t}(10ms) \times 0.943, T_j = T_{jm}$

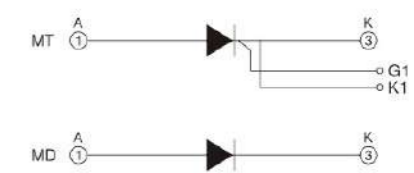

One Unite Thyristor Module(mt)

Type	IT(AV)	VRRM	VTM@IFM		IDRM	IRRM	IGT	IGT	IH	dv/dt	di/dt	ITSM	Rjc	Tjm	Viso	Outline
	A	V	V	A	mA	mA	V	V	mA	V/μS	A/μS	A×10 ³	°C/w	°C	V(AC)	
MT25A	25	500-2500	1.69	80	8	100	2.5	100	800	50	0.55	0.950	125	2500	17	
MT55A	55	500-2500	1.50	170	8	100	2.5	100	800	50	1.25	0.530	125	2500	17	
MT90A	90	500-2500	1.94	270	15	100	2.5	100	800	100	2.00	0.280	125	2500	17/18	
MT110A	110	500-2500	1.90	330	20	100	2.5	100	800	100	2.40	0.250	125	2500	17/18	
MT130A	130	500-2500	1.96	410	25	150	2.5	100	800	100	3.80	0.200	125	2500	19	
MT160A	160	500-2500	1.90	480	25	150	2.5	100	800	100	5.40	0.170	125	2500	19	
MT200A	200	500-2500	1.90	600	30	180	2.5	100	800	100	7.20	0.140	125	2500	19	
MT250A	250	500-2500	1.73	750	30	180	2.5	100	800	100	8.50	0.120	125	2500	19	
MT300A	300	500-2500	1.58	900	40	80	2.5	100	800	100	9.30	0.100	125	2500	19/20	
MT350A	350	500-2500	1.45	1050	40	180	2.5	100	800	100	11.00	0.090	125	2500	19/20	
MT500A	500	500-2500	1.44	1500	40	200	3.0	100	800	100	16.0	0.065	125	2500	19/20	

One Unite Thyristor Module(md)

Type	IT(AV)	VRRM	VTM@IFM		IRRM	IF(RMS)	IFSM	Rjc	Tjm	Viso	Outline
	A	V	V	A	mA	A	A×100	°C/w	°C	V(AC)	
MD×55A	55	500-2500	1.45	170	86	86	1.30	0.700	0.700	2500	17
MD×90A	90	500-2500	1.33	270	141	141	2.30	0.470	0.470	2500	17
MD×130A	130	500-2500	1.56	480	212	251	6.00	0.230	0.230	2500	17/18
MD×200A	200	500-2500	1.38	600	314	314	8.00	0.210	0.210	2500	19
MD×300A	300	500-2500	1.35	750	471	393	11.00	0.140	0.140	2500	19/20
MD×500A	500	500-2500	1.50	1500	785	550	15.00	0.110	0.110	2500	19/20



Fast Turn-off Thyristor/fast Rectifier Diode Module

Features

- The chips are electrically insulated from basom platen 2500V AC voltage.
- Packaged as per international standard.
- Complete pressure connection structure with excellent.
- Temperature characteristics and power cycling capacity.
- Forced air cooling for modules below 200A and air cooling or water cooling for modules above 300A.
- Simple installation convenient use and maintenance.

Application

- Inverter.
- Induction heating.
- Chopper.

Circuit Configurations

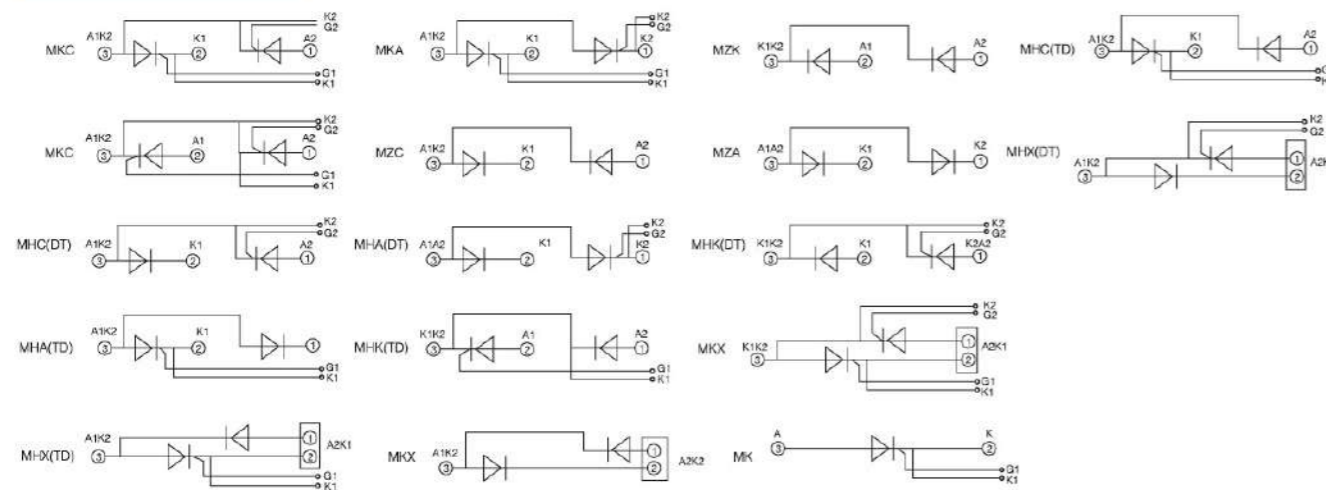

Specification

IT(AVC)@Tc	VDRM VRRM	VTM@ITM	IDRM IRRM	IGT	IGT	IH	dv/dt	di/dt	tq	IT(RMS)	ITSM	Rjc	Tjm	Viso	Outline		
A	V	V	A	mA	mA	V	V/μS	A/μS	Us	A	A×100	°C/w	°C	V(AC)			
50	85	600-1600	1.78	450	40	180	2.5	100	800	200	15-35	236	4.00	0.140	115	2500	4
100	85	600-1600	1.77	600	50	180	2.5	100	800	200	15-35	314	5.60	0.100	115	2500	4
150	85	600-1600	1.75	900	80	200	3.0	100	800	200	15-35	471	7.80	0.070	115	2500	5/6
200	85	600-1600	2.20	900	50	200	3.0	100	800	200	15-35	471	5.60	0.110	115	2500	6/7
300	85	600-1600	2.10	1200	80	200	3.0	100	800	200	15-35	628	7.80	0.087	115	2500	9
500	55	600-1600	1.78	450	40	180	2.5	100	800	200	15-35	236	4.00	0.140	115	2500	10
600	55	600-1600	1.77	600	50	180	2.5	100	800	200	15-35	314	5.60	0.100	115	2500	11
800	55	600-1600	1.75	900	80	200	3.0	100	800	200	15-35	471	7.80	0.070	115	2500	11
1000	55	600-1600	2.20	900	50	200	3.0	100	800	200	15-35	471	5.60	0.110	115	2500	12
300*	85	600-1600	2.10	1200	80	200	3.0	100	800	200	15-35	628	7.80	0.087	115	2500	13
500*	55	600-1600	2.10	900	50	200	3.0	100	800	200	15-35	236	5.60	0.140	115	2500	14
soo*	55	600-1600	2.20	1200	80	200	3.0	100	800	200	15-35	628	7.80	0.100	115	2500	15



Thyristor/diode Module(non-isolated Type)

Features

- Non-insulating module-boom plate is common electrode
- Packaged as per international standard.
- Complete pressure connection structure-with excellent temperature characteristics and power cycling capacity.
- Maximum junction temperature up to 140°C .
- High surge current.
- Low forward voltage drop.

Application

- Electric welder power supplies.
- Various DC power supplies.

Circuit Configurations



Specification

MTG,MTY

Type	IT(AV)	VDRM VRRM	VTM@ITM	IDRM IRRM	IGT	IGT	IH	dv/dt	di/dt	ITSM	Rjc	Tjm	Outline	
	A	V	V	A	mA	mA	V	V/μS	A/μS	A×103	°C/w	°C		
MT100	100	500-2500	1.67	300	12	100	1.8	100	800	100	3.20	0.250	125	37
MT150	150	500-2500	1.67	450	12	100	1.8	100	800	100	5.10	0.160	125	38/39
MT200	200	500-2500	1.62	600	20	100	1.8	100	800	100	6.50	0.130	125	38/39
MT250	250	500-2500	1.65	750	20	100	1.8	100	800	100	8.50	0.100	125	40
MT300	300	500-2500	1.58	900	25	150	1.8	100	800	100	9.60	0.080	125	40

MDG,MDY

Type	IT(AV)	VDRM VRRM	VTM@ITM	IDRM IRRM	IGT	IH	Rjc	Tjm	Outline	
	A	V	V	A	mA	mA	°C/w	°C		
MDX100	100	500-2500	1.67	300	12	100	100	0.250	125	37
MDX150	150	500-2500	1.67	450	12	100	100	0.160	125	38/39
MDX200	200	500-2500	1.62	600	20	150	100	0.130	125	38/39
MDX250	250	500-2500	1.65	750	20	150	100	0.100	125	40
MDX300	300	500-2500	1.58	900	25	150	100	0.080	125	40

MFG,MFY

Type	IT(AV)IAVI	VDRM VRRM	VTM@ITM	@ITM@IFM	IDRM IRRM	IGT	IGT	IH	dv/dt	di/dt	ITSM	Rjc	Tjm	Outline
	A	V	V	A	mA	mA	V	mA	V/μS	A/μS	A×103	°C/w	°C	
MFX100	100	500-2500	1.67	300	12	100	2.5	100	800	100	3.20	0.250	125	37
MFX150	150	500-2500	1.67	450	12	100	2.5	100	800	100	5.10	0.160	125	38/39
MFX200	200	500-2500	1.62	600	20	150	2.5	100	800	100	6.50	0.130	125	38/39
MFX250	250	500-2500	1.65	750	20	150	2.5	100	800	100	8.50	0.100	125	40
MFX300	300	500-2500	1.58	900	25	150	2.5	100	800	100	9.60	0.080	125	40



Single/three Phases Rectifying Bridge Module

Features

- The chips are electrically insulated from bosom plate, 2500V AC voltage.
- Packaged as per international standard;
- Welded structure, with excellent temperature characteristics and power cycling capacity.
- Maximum junction temperature up to 150 °C, Low forward voltage drop.

Application

- DC power supply of appliance and device, input rectifying power supply of PWM frequency transformer.
- Excitation source for DC motor, Input rectifying of switching power supply.
- Charging of soft starting capacitor, Electric towage and auxiliary current.
- Inversion welder, current charging DC power supply.

Circuit Configurations

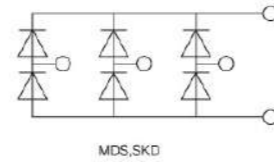
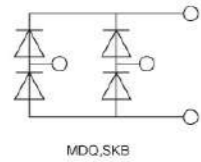

Specification

Type	I _d @T _c		VRRM	VFM@IFM		IRRM	IF(AV)	IF(RMS)	ITSM	R _{jc}	T _{jm}	V _{iso}	Outline
	A	°C		V	A								
MDQ10	10	100	600-2000	1.28	15	5	10	30	0.65	0.15	150	2500	23
MDQ30	30	100	600-2000	1.29	40	6	15	40	0.70	0.16	150	2500	24/27
MDQ50	50	100	600-2500	1.34	75	7	25	50	0.75	0.17	150	2500	24/27
MDQ75	75	100	600-2500	1.38	110	8	38	60	0.75	0.25	150	2500	26/27
MDQ100	100	100	600-2500	1.40	150	9	50	70	1.00	0.30	150	2500	26/27
MDQ150	150	100	600-2500	1.47	230	9	75	86	1.50	0.32	150	2500	28/29
MDQ200	200	100	600-2500	1.47	300	10	75	106	2.50	0.24	150	2500	28/29
MDQ300	300	100	600-2500	1.50	450	10	75	106	2.50	0.15	150	2500	31
MDQ500	500	100	600-2500	1.51	750	12	75	106	2.50	0.15	150	2500	32
MDQ600	600	100	600-2500	1.52	900	12	75	110	2.50	0.15	150	2500	32
MDS10	10	100	600-2500	1.28	15	5	10	30	0.65	0.15	150	2500	23
MDS30	30	100	600-2500	1.29	40	6	15	40	0.70	0.16	150	2500	24/27
MDS50	50	100	600-2500	1.34	75	7	25	50	0.75	0.17	150	2500	24/27
MDS75	75	100	600-2500	1.38	110	8	38	60	0.75	0.25	150	2500	26/27
MDS100	100	100	600-2500	1.40	150	9	50	70	1.00	0.30	150	2500	26/27
MDS150	150	100	600-2500	1.47	230	9	75	86	1.50	0.32	150	2500	28/29
MDS200	200	100	600-2500	1.47	300	10	75	106	2.50	0.24	150	2500	28/29
MDS300	300	100	600-2500	1.50	450	10	75	106	2.50	0.15	150	2500	31
MDS500	500	100	600-2500	1.51	750	12	75	106	2.50	0.15	150	2500	32
MDS600	600	100	600-2500	1.52	900	12	75	110	2.50	0.15	150	2500	32

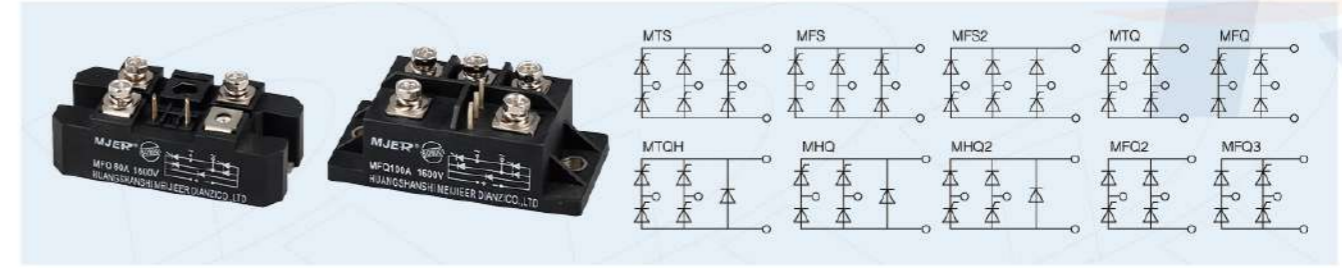

Single Phase.3phase Full Control/half Control Thyristor Bridge Module

Id	IT(AV)	VDRM VRRM	IDRM IRRM	VTM/ITM	IGT	IGT	IH	dv/dt	di/dt	T _{jm}	V _{iso}	Outline	
A	A	V	mA	V	A	mA	V	V/μS	A/μS	°C	V(AC)		
60	20	400-2600	8	1.45	60	100	2.5	100	800	50	125	2500	26/27
90	30	400-2600	15	1.45	90	100	2.5	100	800	100	125	2500	26/27
130	44	400-2600	25	1.45	130	150	2.5	100	800	100	125	2500	28/29
150	50	400-2600	25	1.50	150	180	2.5	100	800	100	125	2500	28/29
200	67	400-2600	30	1.50	200	180	2.5	100	800	100	125	2500	29
300	100	400-2600	40	1.50	300	180	2.5	100	800	100	125	2500	31
450	150	400-2600	40	1.50	450	200	3.0	100	800	100	125	2500	32

Single-phase Full Control/half Control Thyristor Bridge Modules (MTQ, MFQ, MTQH, MHQ)

Id	IT(AV)	VDRM VRRM	IDRM IRRM	VTM/ITM	IGT	VGT	IH	dv/dt	di/dt	T _{jm}	V _{iso}	Outline	
A	A	V	mA	V	A	mA	V	V/μS	A/μS	°C	V(AC)		
60	30	400-2600	8	1.45	60	100	2.5	100	800	50	125	2500	26/27
90	44	400-2600	15	1.45	90	100	2.5	100	800	100	125	2500	26/27
130	50	400-2600	25	1.45	130	150	2.5	100	800	100	125	2500	28/29
150	67	400-2600	25	1.50	150	180	2.5	100	800	100	125	2500	28/29
200	100	400-2600	30	1.50	200	180	2.5	100	800	100	125	2500	29
300	150	400-2600	40	1.50	300	180	2.5	100	800	100	125	2500	31
450	225	400-2600	40	1.50	450	200	3.0	100	800	100	125	2500	32

Three-phase Bridge Rectifier Output Controllable Module

Typical Applications

- For AC/DC motor controls.
- Rectifying power supplies.
- Welder, frequency converters.
- UPS power supply.
- Battery charge and discharge.

Features

- I_d@T_d0°C : 30A-300A.
- VRRM : 600-2000V.
- Welding technique under the production of vacuum and hydrogen gas.
- Electrical insulation class: chips and baseboard 2500 VAC voltage.

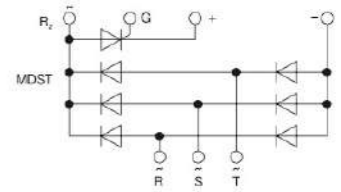

Connecting Program

Typical Applications

Apply three-phase AC input and DC output. Terminals R2 and R share single-phase current and conduct the energy in double sides. Terminal G use 5-24VDC which may conduct current from transformer terminal.

Type	I _d @T _c		IF(AV)	VRRM	IRRM	IGT	VGT	dv/dt	di/dt	VTM/ITM		T _{jm}	V _{iso}
	A	V								V	A		
MDST30	30	100	10	600-2000	8	100	0.8-1.5	800	50	1.45	30	125	2500
MDST60	60	100	20	600-2000	8	100	0.8-1.5	800	100	1.45	60	125	2500
MDST100	100	100	35	600-2000	10	150	0.8-1.5	800	100	1.45	100	125	2500
MDST150	150	100	50	600-2000	10	180	0.8-1.5	800	100	1.50	150	125	2500
MDST200	200	100	68	600-2000	10	180	0.8-1.5	800	100	1.50	200	125	2500
MDST300	300	100	100	600-2000	10	180	0.8-1.5	800	100	1.50	300	125	2500

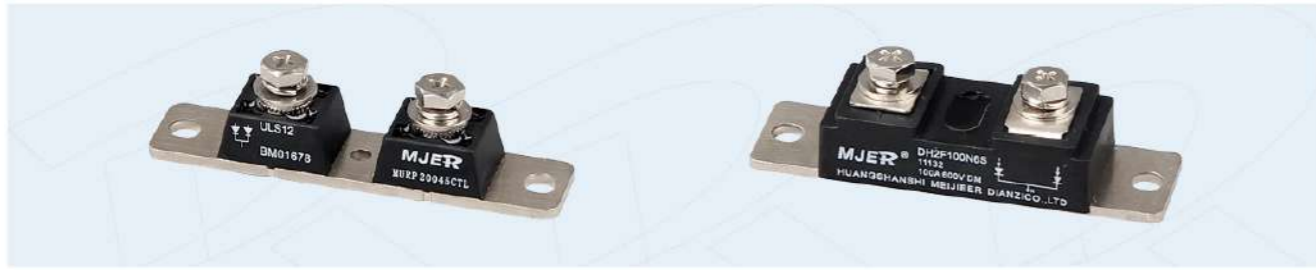

Schottky/super Fast Recovery Diode Module

Features

- The chips are electrically insulated from basom plate, 2500V AC voltage.
- Packaged as per international standard.
- Complete pressure connection structure, with excellent.
- Temperature characteristics and power cycling capacity.
- Forced air cooling for modules below 200A and air cooling or water cooling for modules above 300A.
- Simple installation, convenient use and maintenance.

Application

- UPS.
- Induction heating.
- Chopper.

Part Number Type & Circuit

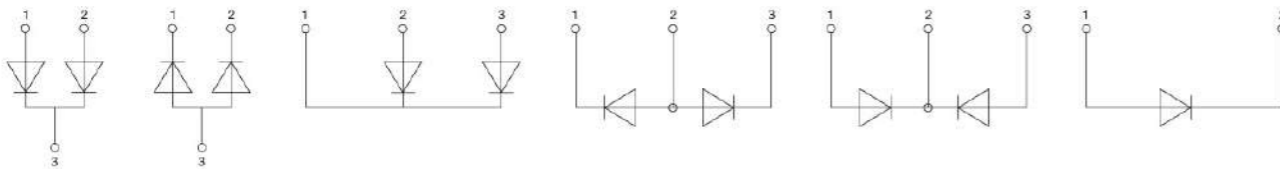

Mbrp, mur Schottky Diode Module Mbrp, Mup

Type	IF(AV)	VRRM	IFSM	VF	TJ	EAS	IRM	dv/dt	Ls	CI	Outline
	A	V	V	A	°C	MJ	mA	A/μS	nH	pF	
M**50	50	25-40	10.00	0.35	-55~150	180	10	10.000	3.0	10.300	14 Page Outline
M**100	100	25-35	20.00	0.40	-55~150	180	10	10.000	3.0	10.300	
M**200	200	35-45	25.00	0.45	-55~150	180	10	10.000	3.0	10.300	
M**300	300	35-45	25.00	0.45	-55~150	180	15	10.000	3.0	10.300	
M**400	400	35-45	25.00	0.45	-55~150	180	20	10.000	4.0	10.300	
M**600	600	35-45	25.00	0.45	-55~150	180	25	10.000	4.0	10.300	
M**800	800	35-45	25.00	0.50	-55~150	180	25	10.000	4.0	10.300	
M**1000	1000	40-50	30.00	0.55	-55~150	180	30	10.000	4.0	10.300	

Outline

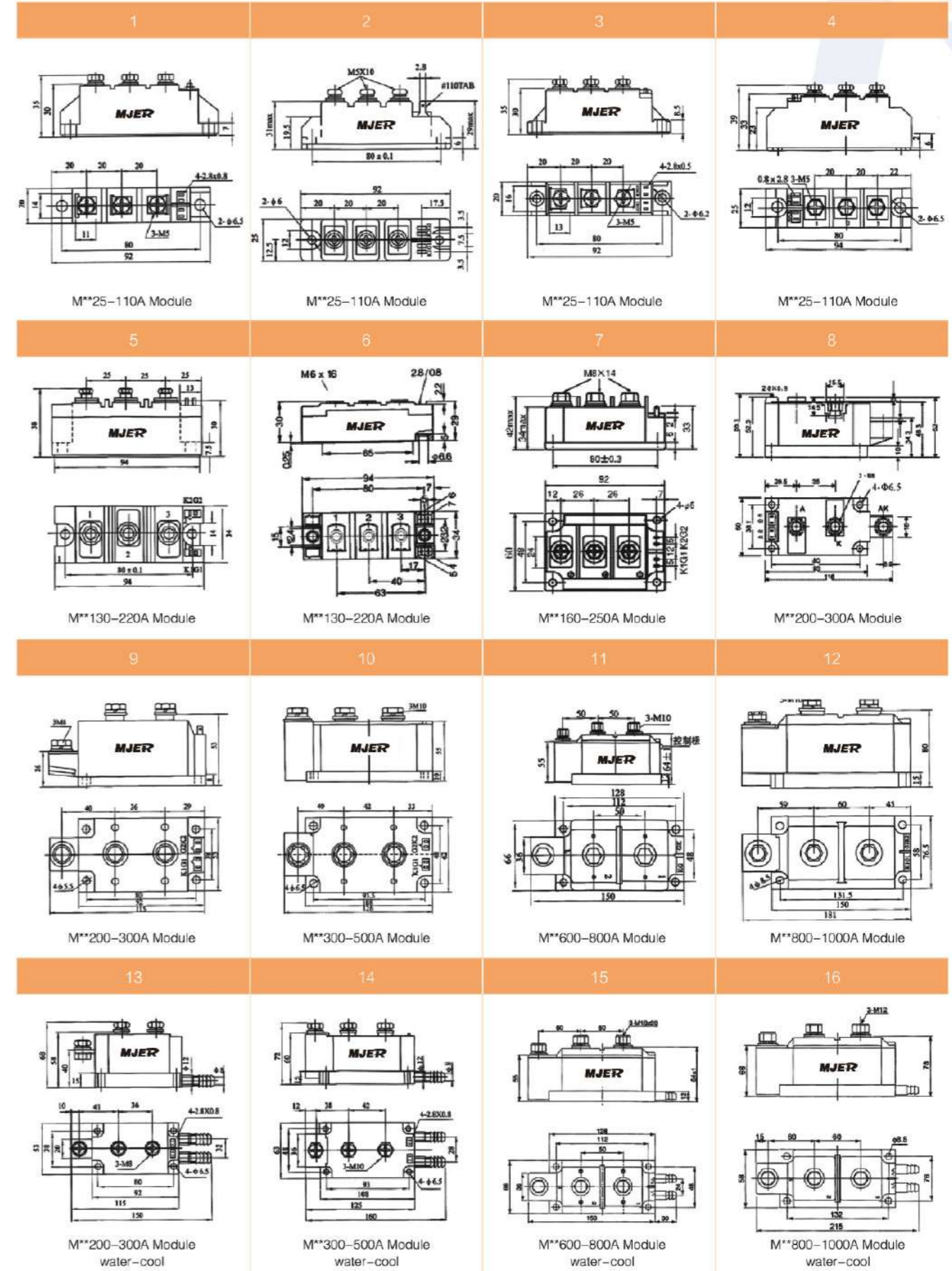
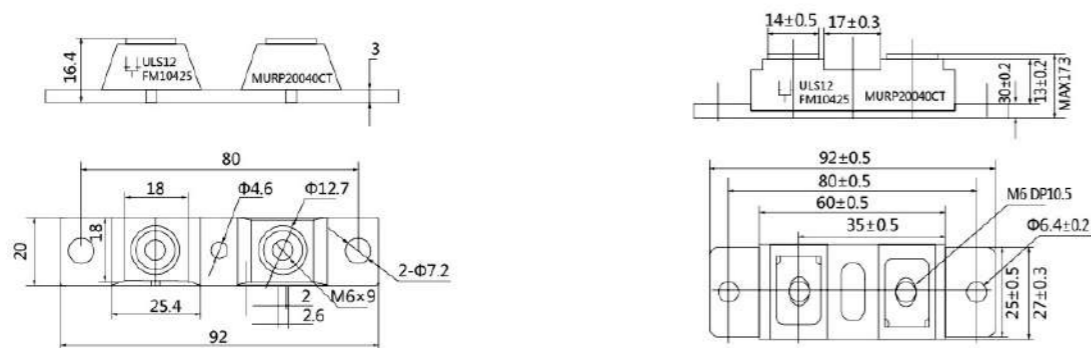

<p>17</p> <p>M**25-10A SINGLE MODULE</p>	<p>18</p> <p>M**25-110A SINGLE MODULE</p>	<p>19</p> <p>M**150-300A SINGLE MODULE</p>	<p>20</p> <p>M**300-500A SINGLE MODULE</p>
<p>21</p> <p>M**600-800A MODULE</p>	<p>22</p> <p>M**1000-1500A MODULE</p>	<p>23</p> <p>M**10-30A MODULE</p>	<p>24</p> <p>M**30-60A MODULE</p>
<p>25</p> <p>M**30-60A MODULE</p>	<p>26</p> <p>M**50-1000A MODULE</p>	<p>27</p> <p>M**50-100A MODULE</p>	<p>28</p> <p>M**150-250A MODULE</p>
<p>29</p> <p>M**150-250A MODULE</p>	<p>30</p> <p>M**200-250A MODULE</p>	<p>31</p> <p>M**250-300A MODULE</p>	<p>32</p> <p>M**350-500A MODULE</p>

<p>33</p> <p>V**25-100A MODULE</p>	<p>34</p> <p>V**110-250A MODULE</p>	<p>35</p> <p>40-100A MODULE</p>	<p>36</p> <p>V**16-36A MODULE</p>
<p>37</p> <p>M**40-130A MODULE non-insulation, SANREX TYPE</p>	<p>38</p> <p>M**150-200A MODULE non-insulation, SANREX TYPE</p>	<p>39</p> <p>M**150-200A MODULE non-insulation, MITSUBITION TYPE</p>	<p>40</p> <p>M**250-300A MODULE non-insulation, MITSUBITION TYPE</p>
<p>41</p> <p>Generator bridge rectifier 40-70A</p>	<p>42</p> <p>Generator bridge rectifier 70-100A</p>	<p>43</p> <p>Power Module DBC type 200-300A</p>	<p>44</p> <p>IR/SEMIKRON SIZE 400-600A</p>
<p>45</p> <p>150-200A non-insulation, Korea type</p>	<p>46</p> <p>50-100A half bridge IGBT Module</p>	<p>47</p> <p>50-100A half bridge IGBT Module</p>	<p>48</p> <p>200-600A Single Unite IGBT Module</p>

Product Application

GGX SSR the company's production is the use of a switch performance of foreign advanced technology and device manufacturing excellent new contactless electronic switch device. The input end requires only a small control current, with TTL, HTL, CMOS integrated circuit better compatibility; and the output circuit adopts thyristor or high power transistor to connect and disconnect the load current. Between input and output by the photoelectric coupling, on-off no movable contact member, therefore has reliable, fast switching speed, no noise, long service life, small volume, no spark, corrosion proof and anti vibration etc. At present it has been widely used in computer peripheral equipment, electric heating thermostat; CNC machine, remote control system, industrial automation equipment; signal lamps, traffic lights, lighting, stage lighting control equipment; instruments, medical equipment, copiers, printing machine, rubber and plastic machinery, automatic washing machine; in addition to the chemical, coal and other required Explosion, damp proof, there are a lot of use are anti-corrosion situation, has become the relay family (EMR) of the ideal upgrade product.

Models And Implications

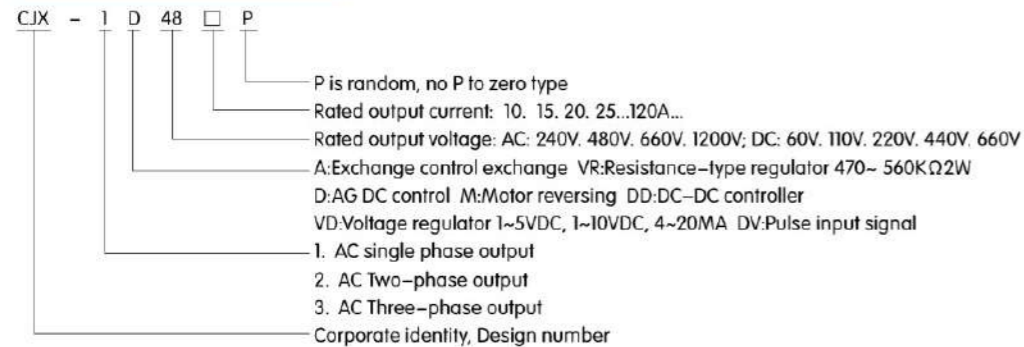

Zero input are constant current: DC3~32V (trigger current is greater than or equal to 5mA (vertical) except 3A~5A, IN3~12V); random inputs are series resistance type: DC4~8(trigger current set equal to 10mA).

Practical Solid State Relay Circ

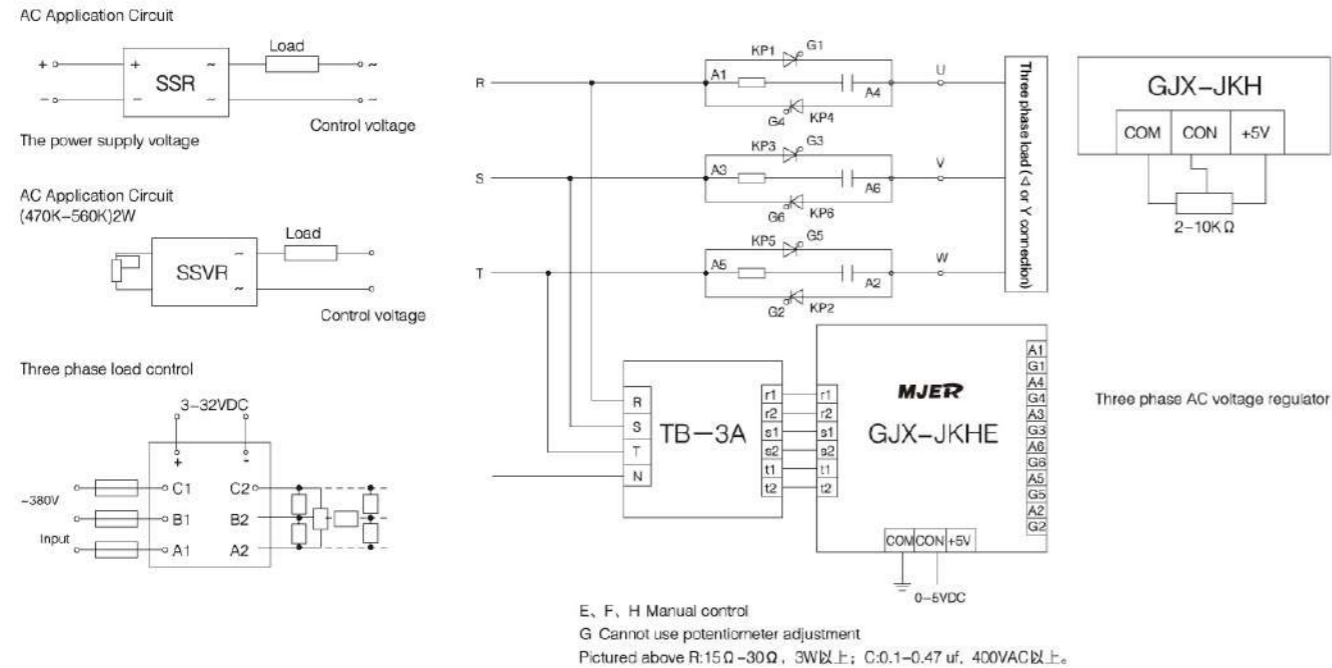

Note: the coefficient of safety of working current, resistive resistive load 2-3 times es, 5-7 times of inductive load.



Single Phase SSR

SSR Solid State Relays are AC relays, Triac Output, The trial version of the zero switching relay is an inexpensive solution for resistive loads. The zero switching relay switches on when the AC sine voltage just crosses zero, and switches off when the current crosses zero.

Features

- Rated operational current 10 to 40 Amps.
- Rated operational voltage 240V or 440V.
- 4000 Vrms optical isolation. (Input/Output).
- Input voltage range 4 to 16 Vdc, 3 to 32 Vdc or 90 to 280 Vac.
- Both "Zero Voltage" & phase controllable "Random Switching" versions.
- LED-indication for control input Vac.

Single Phase SSR Specification

Type	Voltage level	220VAC		380VAC		480VAC	
		Current level	Zero	Random type	Zero	Random type	Zero
Four square mounting type	10A	220D10	220D10P	380D10	380D10P	480D10	480D10P
	25A	220D25	220D25P	380D25	380D25P	480D25	480D25P
	40A	220D40	220D40P	380D40	380D40P	480D40	480D40P
Enhanced Four square mounting type	50A	H220D50	H220D50P	H380D50	H380D50P	H480D50	H480D50P
	60A	H220D60	H220D60P	H380D60	H380D60P	H480D60	H480D60P
	80A	H220D80	H220D80P	H380D80	H380D80P	H480D80	H480D80P
	90A	H220D90	H220D90P	H380D90	H380D90P	H480D90	H480D90P
	100A	H220D100	H220D100P	H380D100	H380D100P	H480D100	H480D100P
	120A	H220D120	H220D120P	H380D120	H380D120P	H480D120	H480D120P

Dimension

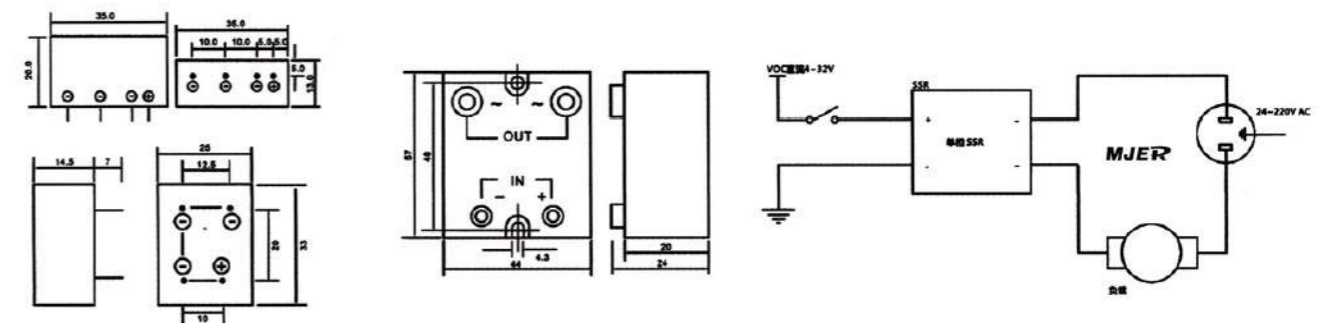



H3 60T02000A Industrial Grade SSR

H3 are power line relays allowing 10 to 150 Amps switching power, with voltage ratings from 280 to 480VAC. H3 series is Dual SCR Power Hybrid technology provides highly efficient thermal management for greatly increased cyclic life.

Features

- High power and high current, High performance/ Low cost circuit design.
- Logic compatible current regulated input. 4000 Vrms optical isolation.
- Both "Zero Voltage" & phase controllable "Random Switching" versions High voltage (1200Vpk) versions for 480V rms service.
- LED-indicator for control input, Control voltage range: 4 to 16 Vdc or 3 to 32 Vdc.
- Industry standard "SGR Modules" package.

List of models for single phase AC solid state relay

Type	Voltage level	220VAC		380VAC		480VAC	
		Current level	Zero	Random type	Zero	Random type	Zero
Rectangular Installation type	60A	H220D60	H220D60P	H380D60	H380D60P	H480D60	H480D60P
	80A	H220D80	H220D80P	H380D80	H380D80P	H480D80	H480D80P
	100A	H220D100	H220D100P	H380D100	H380D100P	H480D100	H480D100P
	120A	H220D120	H220D120P	H380D120	H380D120P	H480D120	H480D120P
	150A	H220D150	H220D150P	H380D150	H380D150P	H480D150	H480D150P
	200A	H220D200	H220D200P	H380D200	H380D200P	H480D200	H480D200P
	250A	H220D250	H220D250P	H380D250	H380D250P	H480D250	H480D250P
	300A	H220D300	H220D300P	H380D300	H380D300P	H480D300	H480D300P
	350A	H220D350	H220D350P	H380D350	H380D350P	H480D350	H480D350P
	400A	H220D400	H220D400P	H380D400	H380D400P	H480D400	H480D400P
	500A	H220D500	H220D500P	H380D500	H380D500P	H480D500	H480D500P
	800A	H220D800	H220D800P	H380D800	H380D800P	H480D800	H480D800P
1000A	H220D1000	H220D1000P	H380D1000	H380D1000P	H480D1000	H480D1000P	
2000A	H220D2000	H220D2000P	H380D2000	H380D2000P	H480D2000	H480D2000P	

Dimension

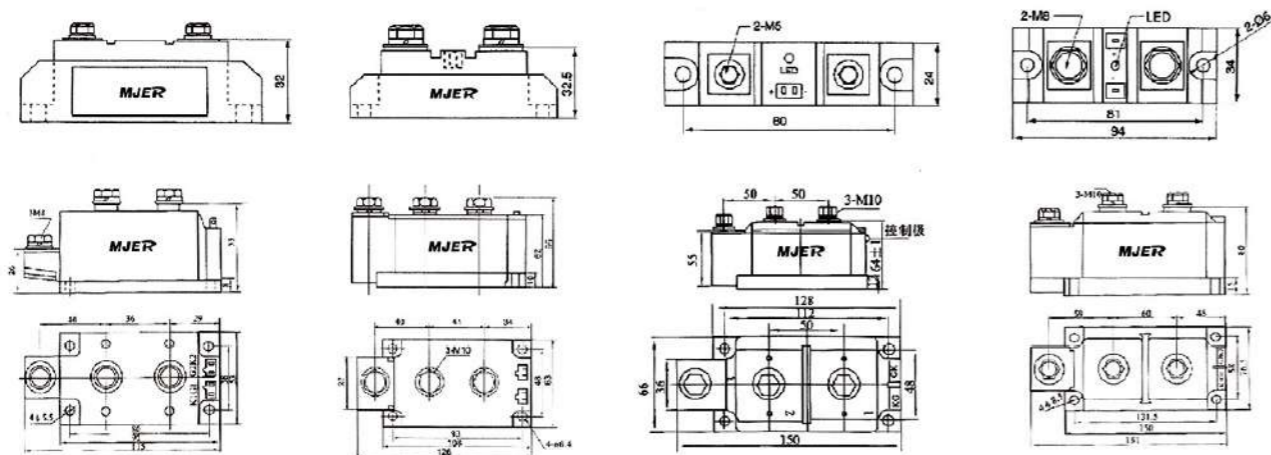

GJX10 T0 400A Three Phase SSR

GJX series three phase Solid State Relays is used three phase loads. SCR Output. GJX series is Dual SCR Power Hybrid technology provides efficient thermal management for greatly increased cyclic life.

Features

- Rated operational current 3x10/400.
- High voltage(1400Vpk)versions for 530V rms service. 2500kV rms Optical Isolation. (input/output)
- Both "Zero Voltage" & phase controllable "Random Switching" versions.
- Input Voltage Range 4 to 16 Vdc, 3 to 32 Vdc, 90 to 280 Vac.
- LED-indicator for control input.

Selection Guide

Voltage	Control voltage	Rated operational current									
		10A	15A	25A	40A	60A	80A	100A	120A	150A	200A
480VAC	3 to 32 Vdc	GJX1048ZD3	GJX1548ZD3	GJX2548ZD3	GJX4028ZD3	GJX6048ZD3	GJX8048ZD3	GJX10048ZD3	GJX12048ZD3	GJX15048ZD3	GJX20048ZD3
"zero Voltage"	90 to 280 Vac	GJX1048ZA4	GJX1548ZA4	GJX2548ZA4	GJX4028ZA4	GJX6048ZA4	GJX8048ZA4	GJX10048ZA4	GJX12048ZA4	GJX15048ZA4	GJX20048ZA4
530VAC	3 to 32 Vdc	GJX1053ZD3	GJX1553ZD3	GJX2553ZD3	GJX4028ZD3	GJX6053ZD3	GJX8053ZD3	GJX10053ZD3	GJX12053ZD3	GJX15053ZD3	GJX20053ZD3
"zero Voltage"	90 to 280 Vac	GJX1053ZA4	GJX1553ZA4	GJX2553ZA4	GJX4028ZA4	GJX6053ZA4	GJX8053ZA4	GJX10053ZA4	GJX12053ZA4	GJX15053ZA4	GJX20053ZA4
480VAC	3 to 32 Vdc	GJX1048RD3	GJX1548RD3	GJX2548RD3	GJX4028RD3	GJX6048RD3	GJX8048RD3	GJX10048RD3	GJX12048RD3	GJX15048RD3	GJX20048RD3
"zrandom"	90 to 280 Vac	GJX1048RA4	GJX1548RA4	GJX2548RA4	GJX4028RA4	GJX6048RA4	GJX8048RA4	GJX10048RA4	GJX12048RA4	GJX15048RA4	GJX20048RA4
530VAC	3 to 32 Vdc	GJX1053RD3	GJX1553RD3	GJX2553RD3	GJX4028RD3	GJX6053RD3	GJX8053RD3	GJX10053RD3	GJX12053RD3	GJX15053RD3	GJX20053RD3
"zrandom"	90 to 280 Vac	GJX1053RA4	GJX1553RA4	GJX2553RA4	GJX4028RA4	GJX6053RA4	GJX8053RA4	GJX10053RA4	GJX12053RA4	GJX15053RA4	GJX20053RA4

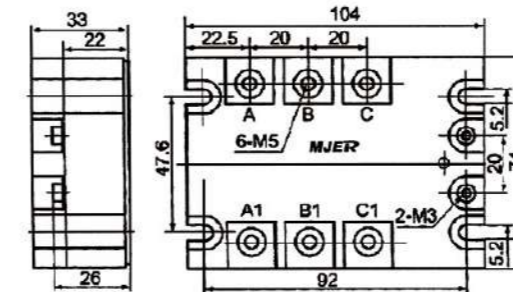

H: SCR
 10: 3x10A, 15: 3x10A, 25: 3x25A
 40: 3x40A, 60: 3x60, 80: 3x80A
 100: 3x100A, 120: 3x120A
 48: 480VAC, 53: 530VAC
 Z: Zero Voltage, R: Random Switching
 D1: DC 4 to 16V . D3: DC 3 to 32V,
 A4: 90 to 280V, D2: 15 to 30V

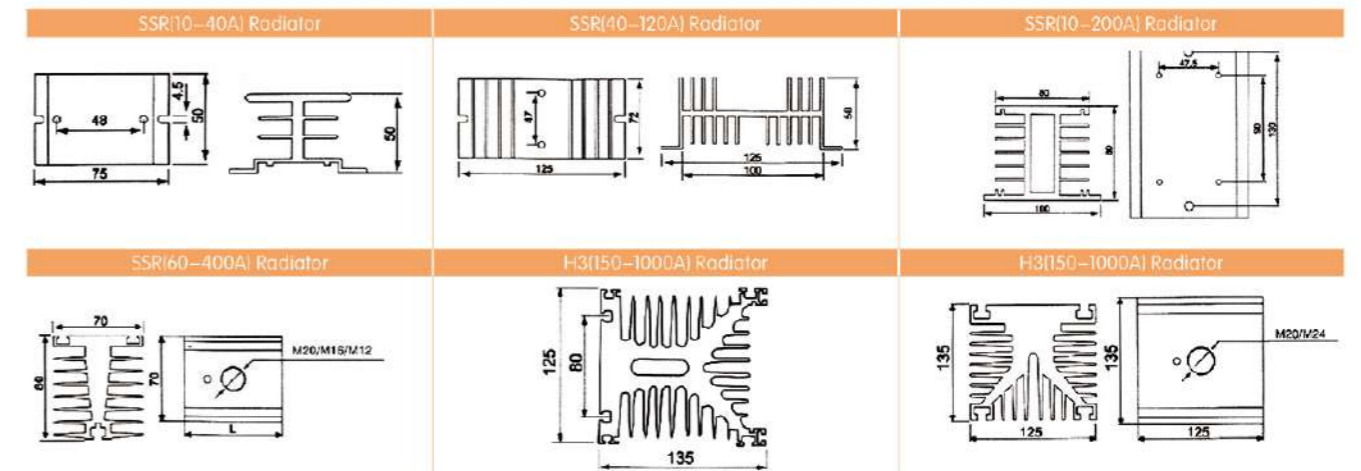



DTY Single-phase\sty Three Phase AC Phase Shift Voltage Adjusting Interlligent Module

Features

It is a kind of big power multi functional module consisting of three phase thyristor main circuit, phase shift triggering and monitoring circuit, phase-lacking protective circuit, overheat protective circuit, and limit current protective circuit, which is a complete electric phase shift and controlling system with protections and can adjust three phase voltage manually automatically. it is widely applicable for speed adjusting of three phase AC motor, electrical heating control, various power supply, industrial automation, chemical industry, mining, textile fields and communications etc, Besides, it has 0-10V and 4-20mA input interface but on special phase sequences for AC input of main circuit and features high controlling accuracy, stable performance and convenient use.

Parameters Of Main Circuit

Parameter unit	Nominal current Arms	Max working current Arms	Interdiction voltage of SCR Vpk	Frequency Hz	Dv/dt V/sec	Di/dt A/sec	Breaking leakage current(I _{Max}) MArms	Making voltage drop I(Max) Vrms	Insulating voltage (terminal/soleplate) Vrms	Weight kg
Value	50	3×50	1200	50/60	500	100	≤ 8	1.6	≥ 2500	2.2
	70	3×70	1200	50/60	500	100	≤ 10	1.6	≥ 2500	2.2
	120	3×120	1200	50/60	500	100	≤ 10	1.8	≥ 2500	2.2
	200	3×200	1200	50/60	500	100	≤ 10	1.8	≥ 2500	2.2
	250	3×250	1200	50/60	500	100	≤ 15	1.8	≥ 2500	2.2
	350	3×350	1200	50/60	500	100	≤ 15	1.8	≥ 2500	2.2
	500	3×350	1200	50/60	500	100	≤ 20	1.8	≥ 2500	2.2

Circuit Diagram

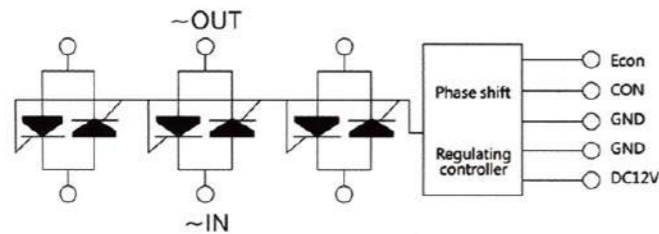

Dimension

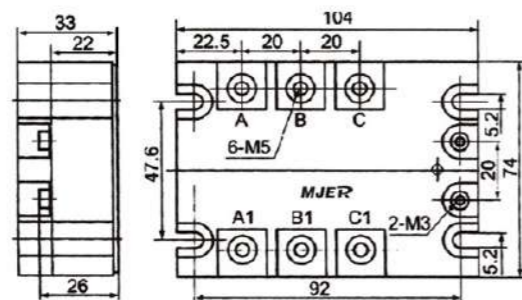

Feature

IGBT is a MOSFET and bipolar transistor made of a composite device, the input is extremely PNP transistor, which intergration of these two devices are the advantage of.

With a small power MOSFET device driver and switching speed advantage.

With a bipolar device saturation pressure lowering of the advantage of large capacity, it frequency response range and power MOSFET transistor, and is available to work on dozen of kHz frequency range.

Module type naming

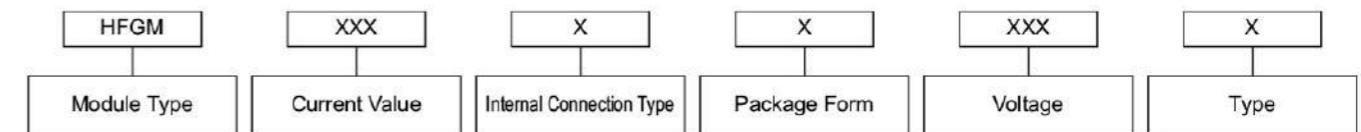

- Current value: It indicates the collector DC (continuous) current
- Internal connection type: T: bridge arm; L: low end connection; H: high end connection;
- D: single-tube structure
- Package form: A:A-pak S:Inf-A-pak D: Dual-Inf-A-pak
- Voltage: The voltage value at the collector and emitter is: voltage×10[V]
- Type: U type: super fast type; K type: super fast type provided with short circuit function (NPT)

Type	VCES	Ic@Tc		VCE(ON)	ICP	IGBT	Package
	V	A@25°C	A@°C	V	A	Type	
HFGM75D06V1	600	100	75/70	1.9	140	PT	V1
HFGM100D06V1	600	130	100/70	2.2	200	PT	V1
HFGM150D06V1	600	200	150/70	1.9	350	PT	V1
HFGM200D06V2	600	260	200/70	2.2	400	PT	V2
HFGM75D06AV1	600	100	75/80	1.5	140	Trench	V1
HFGM100D06AV1	600	130	100/80	1.5	200	Trench	V1
HFGM150D06AV1	600	210	150/80	1.5	350	Trench	V1
HFGM200D06AV1	600	260	200/80	1.5	400	Trench	V1
HFGM200D06AV2	600	260	200/80	1.5	400	Trench	V2
HFGM300D06AV3	600	360	300/80	1.5	600	Trench	V3
HFGM400D06AV3	600	450	400/80	1.5	800	Trench	V3
HFGM75D12SV1	1200	100	75/80	2.8	200	NPT	V1
HFGM100D12SV1	1200	130	100/70	3.2	200	NPT	V1
HFGM150D12SV3	1200	200	150/70	2.8	350	NPT	V3
HFGM200D12SV3	1200	260	200/70	3.2	400	NPT	V3
HFGM100D12AV1	1200	130	100/80	1.7	200	Trench	V1
HFGM150D12AV3	1200	200	150/80	1.7	350	Trench	V3
HFGM200D12AV3	1200	260	200/80	1.7	400	Trench	V3
HFGM300D12AV3	1200	360	300/80	1.7	600	Trench	V3



Bridge Rectifiers

Features

- Current: 5-300A.
- Voltage: 100-1600V.
- All models feature the same compact dimensions to provide a uniform mounting pitch.
- Glass passivated diode chips.
- Excellent power/volume ratio.
- High thermal conductivity package, electrically insulated case.

Application

- Eliminator supply.
- Industrial automatic control.
- Numerically-controlled machinery, telecontrol system.

Characteristics Valve For Bridge Rectifiers

Type	VFM(V)	VRRM(V)	IRRM(MV)	VISOL(V)	Ty(°C)	Weight(g)	Outline
KBPC5A-35A	≤ 1.30	100-1600	5	2500	(-40°C)~150°C	29	No
QL15A-40A	≤ 1.30	100-1600	5	2500	(-40°C)~150°C	35	
QL25A-50A	≤ 1.30	100-1600	5	2500	(-40°C)~150°C	47	
QL320A-100A	≤ 1.40	100-1600	7	2500	(-40°C)~150°C	315	
QL4150A-300A	≤ 1.50	100-1600	10	2500	(-40°C)~150°C	1200	
SQL320A-300A	≤ 1.40	100-1600	7	2500	(-40°C)~150°C	315	
SQL3150A-300A	≤ 1.50	100-1600	10	2500	(-40°C)~150°C	1200	
ZPQ10A-40A	≤ 1.30	100-1600	5	2500	(-40°C)~150°C	220	
4ZQ10A-40A	≤ 1.30	100-1600	5	2500	(-40°C)~150°C	150	
6ZQ10A-40A	≤ 1.30	100-1600	5	2500	(-40°C)~150°C	395	

Circuit Diagram

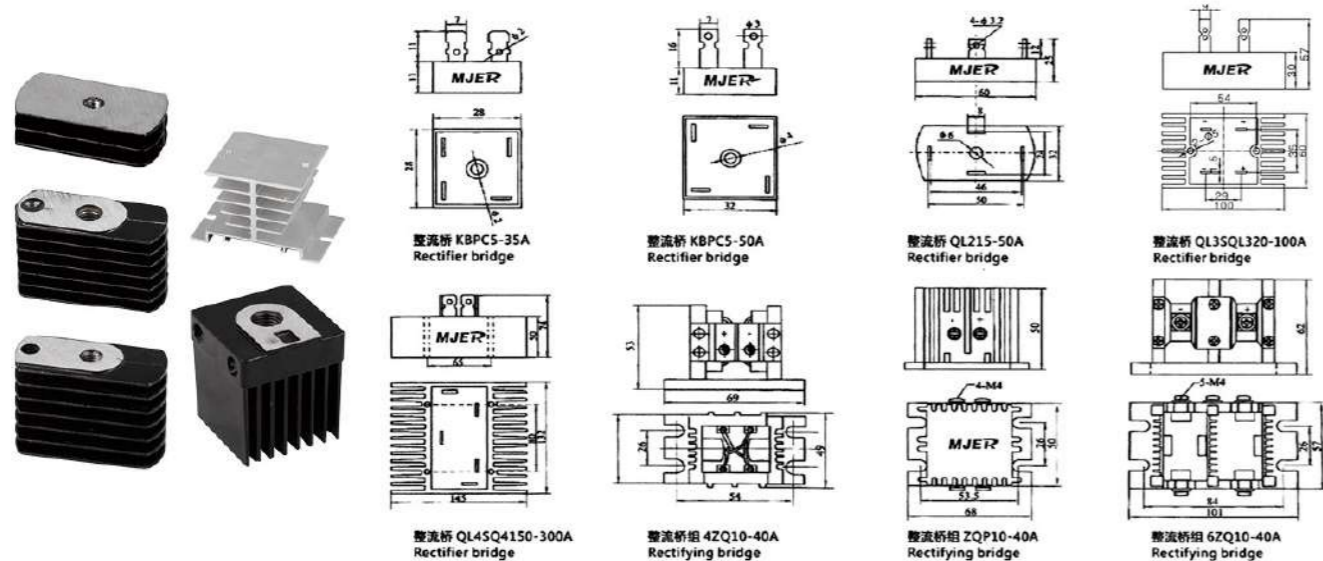

Features

- High surge current capability
- Stud cathode and stud anode version
- Wide current range
- Metric device version available

Typical Applications

- Battery charges
- Converters
- Power supplies
- Machine tool controls
- Welder
- Motor controls

Ordering Information Table

Device Code: **FR 70 HF R 120 M L**

① ② ③ ④ ⑤ ⑥ ⑦

- 1 - None=Standard recovery diodes; FR=Fast recovery diodes
- 2 - Current code=IF(AV)
- 3 - Outline code: F=D0-4 case 6A-25A; HF=D0-5 case 30A-85A; U=D0-8, D0-9 case 100A-300A
- 4 - None=Stud Normal Polarity(cathode to stud); R=Stud Reverse Polarity (anode to stud)
- 5 - Voltage code=code×10=VRRM
- 6 - None=Standard Inch Device; M=Metric Device
- 7 - Bigger size

Notice: If you need metric size or ceramic version, pls contact with ECC.

Type	IF _{50%}		V _{RM} /V _{SM}		IF _{AVG}	V _{RRM}	I _{ESD}	R _{θj-c}	T _j	M ²	Wt	Outline
	A	V	A	V								
6F(R)	6	1.1	18	9.0	200-1200	≤ 6	≤ 2.0	-40°C ~ +150°C				DO-4
12F(R)	12	1.25	36	19.0	200-1200	≤ 6	≤ 1.2					
16F(R)	16	1.25	48	25.0	200-1200	≤ 12	≤ 1.2					
25F(R)	25	1.1	75	40.0	200-1200	≤ 12	≤ 1.2					
30HF(R)	30	1.3	90	48.0	200-1200	≤ 10	≤ 0.8					DO-5
40HF(R)	40	1.3	120	64.0	200-1200	≤ 10	≤ 0.8					
50HF(R)	50	1.4	150	80.0	200-1200	≤ 10	≤ 0.8					
60HF(R)	60	1.4	180	96.0	200-1200	≤ 12	≤ 0.6					
70HF(R)	70	1.45	210	112.0	200-1600	≤ 12	≤ 0.5					DO-8
85HF(R)	85	1.45	255	136.0	200-1600	≤ 12	≤ 0.4					
100U(R)	100	1.8	300	160.0	200-1600	≤ 15	≤ 0.3					
150U(R)	150	1.5	450	240.0	200-1600	≤ 15	≤ 0.3					
100U(R)L	100	1.8	300	160.0	200-1600	≤ 15	≤ 0.3					DO-30
150U(R)L	150	1.5	450	240.0	200-1600	≤ 15	≤ 0.3					
200U(R)	200	1.3	600	320.0	200-1800	≤ 20	≤ 0.2	DO-9				
250U(R)	250	1.35	750	400.0	200-1800	≤ 20	≤ 0.15					
300U(R)	300	1.35	900	480.0	200-1800	≤ 20	≤ 0.15					
SD400N(R)	400	1.6	1200	640.0	200-2400	≤ 40	≤ 0.07					
SD500N(R)	500	1.6	1500	800.0	200-2400	≤ 40	≤ 0.065	B-8				
SD600N(R)	600	1.5	1800	960.0	200-2400	≤ 40	≤ 0.065					

Bridge Rectifier

Stud Version Semiconductor

Type	IF(AV)		VFM/IFM		IF(RMS)	VPRM	IRRM	RθC	Tc	Tj	M ²	Wt	Outline
	Tc=55°C		25°C										
	A	V	A	A	V	mA	°C/W	μS	°C	N/m	kg		
FR10F(R)	10	1.5	30	16.0	200-800	≤ 6	≤ 2.0	≤ 0.5	-40°C ~ +150°C	≤ 1.0	0.008	DO-4	
FR15F(R)	15	1.55	45	24.0	200-800	≤ 12	≤ 1.2	≤ 0.5		≤ 1.0	0.008		
FR20F(R)	20	1.70	60	32.0	200-800	≤ 12	≤ 1.2	≤ 0.5		≤ 1.0	0.008		
FR40HF(R)	40	1.95	120	64.0	200-1200	≤ 10	≤ 1.2	≤ 0.7		≤ 2.0	0.020	DO-5	
FR50HF(R)	50	1.90	150	80.0	200-1200	≤ 10	≤ 1.2	≤ 0.7		≤ 2.0	0.020		
FR70HF(R)	70	1.85	210	112.0	200-1200	≤ 12	≤ 0.8	≤ 1.0		≤ 2.0	0.020		
FR80HF(R)	85	1.85	255	136.0	200-1200	≤ 12	≤ 0.8	≤ 1.0		≤ 2.0	0.020	DO-8	
FR100U(R)	100	2.05	300	160.0	200-1200	≤ 15	≤ 0.3	≤ 1.5		≤ 12	0.120		
FR100U(R)L	100	2.05	300	160.0	200-1200	≤ 15	≤ 0.3	≤ 1.5		≤ 12	0.140		DO-30
FR150U(R)	150	2.00	450	240.0	200-1200	≤ 20	≤ 0.2	≤ 2.0	≤ 25	0.250	DO-9		
FR200U(R)	200	2.05	600	320.0	200-1200	≤ 20	≤ 0.2	≤ 2.5	≤ 25	0.250			

Diode Stud Version Outline

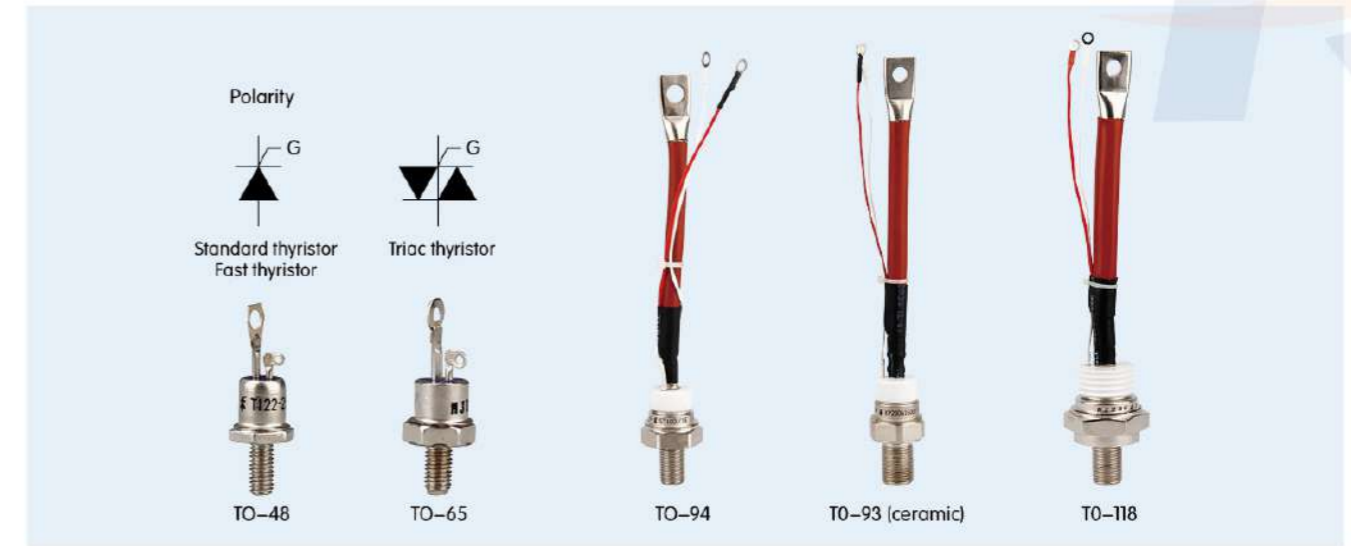
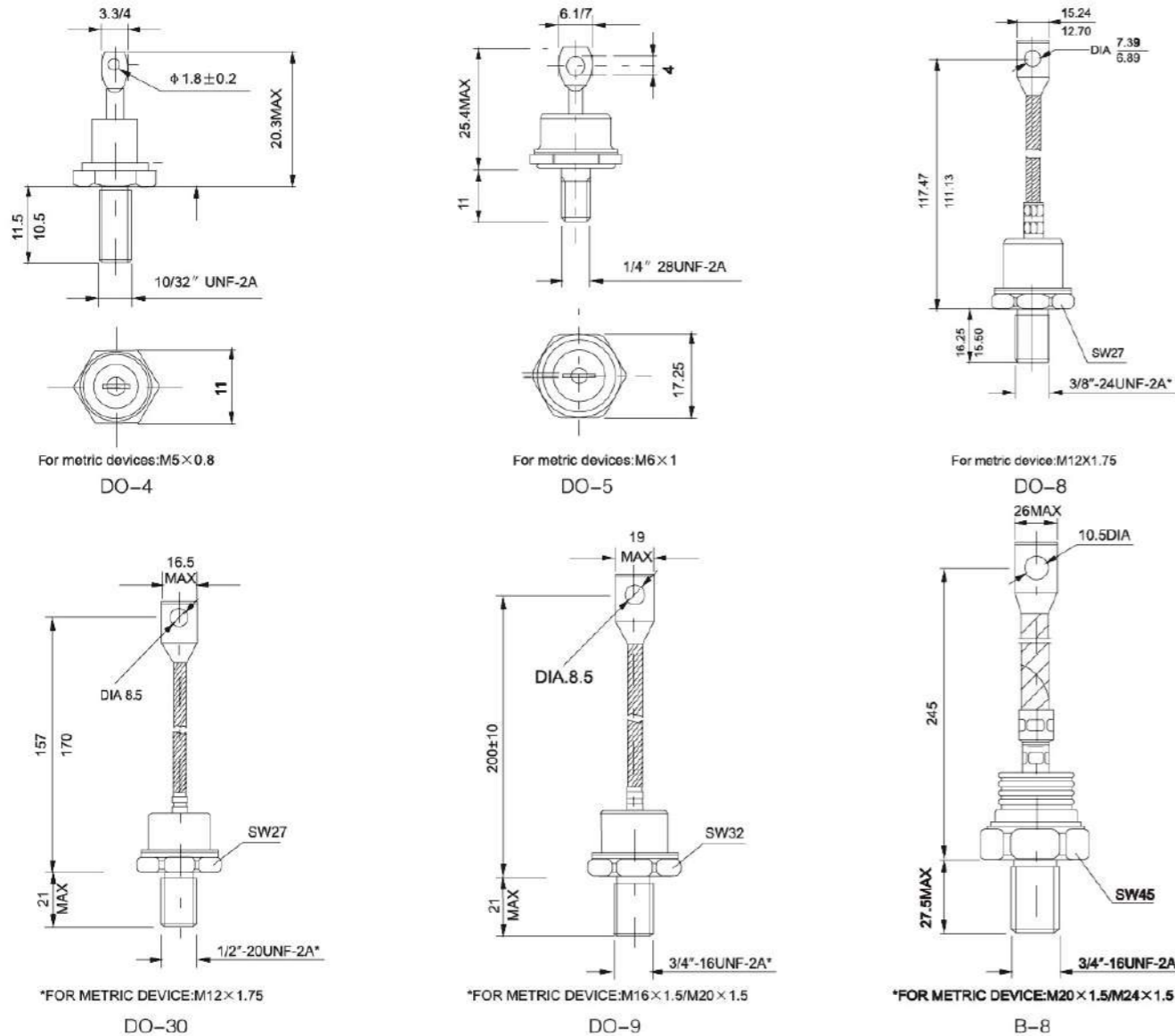

Features

- High current rating
- Excellent dynamic characteristics
- Superior surge capabilities
- Standard package
- Metric Device version available

Typical Applications

- Phase control applications in converters
- Lighting circuits
- Battery charges
- Regulated power supplies and temperature and speed control circuit
- Can be supplied to meet stringent military aerospace and other high-reliability requirements
- Power supplier & motor controls

Ordering Information Table

Device Code	S	50	RIA	120	M	Device Code	ST	300	S	16	M	V
	①	②	③	④	⑤		①	②	③	④	⑤	⑥
	1 - None=Standard thyristor	S=Triac thyristor	K=Fast thyristor				1 - ST=Standard thyristor	SST=Triac thyristor	KST=Fast thyristor			
	2 - Current code=IT(AV)						2 - Current code=IT(AV)					
	3 - Essential part number						3 - S=Stud version device					
	4 - Voltage code=code×10=VRRM						4 - Voltage code=code×100=VRRM					
	5 - None=standard inch device	M=metric device					5 - None=standard inch device	M=metric device				
							6 - None = ceramic seal	V=glass-metal seal				

Notice: If you need metric size, pls contact with ECC.

Type	IF(AV)		VFM/IFM		IF(RMS)	VPRM	IRRM	IGT	VGT	I _α	I _α	d _v /d _t	d _v /d _t	T _c	RθC	M ²	Wt	Outline
	Tc=55°C		25°C															
	A	V	A	A	V	mA	mA	V	mA	mA	mA	mA	°C	°C/W	N/m	kg		
10RIA	10	1.75	30	16	200-1200	≤ 10	10-100	≤ 2.5	≤ 150	≤ 200	≥ 500	≥ 100	-40°C ~ +125°C	≤ 1.8	≤ 2.0	0.016	TO-48	
16RIA	16	1.75	48	25	200-1200	≤ 10	10-100	≤ 2.5	≤ 150	≤ 200	≥ 500	≥ 100		≤ 1.5	≤ 2.0	0.016		
25RIA	25	1.70	75	40	200-1200	≤ 10	10-100	≤ 2.5	≤ 150	≤ 200	≥ 500	≥ 100		≤ 1.0	≤ 2.0	0.016		
40RIA	40	1.95	120	64	200-1200	≤ 12	50-200	≤ 2.5	≤ 150	≤ 200	≥ 500	≥ 100		≤ 1.0	≤ 2.0	0.022	TO-65	
50RIA	50	1.90	150	80	200-1200	≤ 12	50-200	≤ 2.5	≤ 150	≤ 200	≥ 500	≥ 100		≤ 0.8	≤ 2.0	0.022		
ST80S	80	1.6	240	128	200-1600	≤ 15	50-200	≤ 2.5	≤ 200	≤ 400	≥ 800	≥ 100		≤ 0.6	≤ 12	0.160		
ST100S	100	1.6	300	160	200-1600	≤ 15	50-200	≤ 2.5	≤ 200	≤ 400	≥ 800	≥ 100		≤ 0.6	≤ 12	0.160	TO-94	
ST130S	130	1.55	390	208	200-1600	≤ 15	50-200	≤ 2.5	≤ 200	≤ 400	≥ 800	≥ 100		≤ 0.55	≤ 12	0.160		
ST150S	150	1.6	450	240	200-1600	≤ 20	50-200	≤ 2.5	≤ 200	≤ 400	≥ 800	≥ 100		≤ 0.5	≤ 12	0.160		
ST180S	200	1.75	600	320	200-1800	≤ 20	50-200	≤ 2.5	≤ 400	≤ 600	≥ 800	≥ 100	≤ 0.4	≤ 25	0.280	TO-93		
ST230S	250	1.75	750	400	200-1800	≤ 20	50-200	≤ 2.5	≤ 400	≤ 600	≥ 800	≥ 100	≤ 0.2	≤ 25	0.280			
ST280S	280	1.7	840	450	200-1800	≤ 25	50-200	≤ 2.5	≤ 400	≤ 600	≥ 800	≥ 100	≤ 0.15	≤ 25	0.280			
ST300S	300	1.5	900	480	200-2400	≤ 40	50-200	≤ 2.5	≤ 600	≤ 1000	≥ 800	≥ 100	≤ 0.10	≤ 30	0.580	TO-118		
ST330S	330	1.55	990	530	200-2400	≤ 40	50-200	≤ 2.5	≤ 600	≤ 1000	≥ 800	≥ 100	≤ 0.07	≤ 30	0.580			
ST350S	350	1.6	1050	560	200-2400	≤ 40	50-200	≤ 2.5	≤ 600	≤ 1000	≥ 800	≥ 100	≤ 0.06	≤ 30	0.580			

Type	I _{FM}		V _{TM} /I _{TM}		V _{RRM}	I _{RM}	V _{GT}	L _g	l	d ₁ /d ₂	d ₃ /d ₄	T _j	R _{θj-c}	M ²	WI	Outline
	T _{vj} 55°C		25°C													
	A	V	A	V												
S10RIA	10	2.10	30	200-1200	≤ 15	≤ 350	≤ 200	≤ 250	≥ 500	≥ 10	-40°C ~ +125°C	≤ 0.12	≤ 2.0	0.016	TO-48	
S16RIA	16	2.15	48	200-1200	≤ 15	≤ 350	≤ 200	≤ 250	≥ 500	≥ 10	≤ 0.12	≤ 2.0	0.016	TO-48		
S25RIA	25	2.35	75	200-1200	≤ 25	≤ 350	≤ 250	≤ 300	≥ 500	≥ 10	≤ 0.11	≤ 2.0	0.022	TO-65		
S40RIA	40	2.30	120	200-1200	≤ 25	≤ 350	≤ 250	≤ 300	≥ 500	≥ 10	≤ 0.11	≤ 2.0	0.022	TO-65		
S50RIA	50	2.25	150	200-1200	≤ 25	≤ 350	≤ 250	≤ 300	≥ 500	≥ 10	≤ 0.11	≤ 2.0	0.022	TO-65		
SST80S	80	2.05	240	200-1600	≤ 30	≤ 350	≤ 250	≤ 300	≥ 500	≥ 10	≤ 0.10	≤ 12	0.160	TO-94		
SST100S	100	2.10	300	200-1600	≤ 30	≤ 350	≤ 250	≤ 300	≥ 500	≥ 10	≤ 0.10	≤ 12	0.160	TO-94		
SST150S	150	2.25	450	200-1600	≤ 30	≤ 350	≤ 250	≤ 300	≥ 500	≥ 10	≤ 0.09	≤ 25	0.280	TO-93		
SST180S	200	2.40	540	200-1600	≤ 30	≤ 350	≤ 250	≤ 300	≥ 500	≥ 10	≤ 0.09	≤ 25	0.280	TO-93		
SST250S	250	2.40	750	200-1600	≤ 30	≤ 350	≤ 250	≤ 300	≥ 500	≥ 10	≤ 0.08	≤ 30	0.580	TO-118		
SST300S	300	2.45	900	200-1600	≤ 30	≤ 350	≤ 250	≤ 300	≥ 500	≥ 10	≤ 0.08	≤ 30	0.580	TO-118		

Fats Thyristor (Stud Version)

Type	I _{FM}		V _{TM} /I _{TM}		V _{RRM}	I _{RM}	T _g	V _{GT}	V _{GT}	I _{th}	l _L	d ₁ /d ₂	d ₃ /d ₄	T _j	R _{θj-c}	M ²	WI	Outline
	T _{vj} 55°C		25°C															
	A	V	A	V														
K10RIA	10	2.35	30	16	200-1200	≤ 10	10-20	10-100	≤ 2.5	≤ 150	≤ 200	≥ 500	≥ 100	-40°C ~ +125°C	≤ 1.8	≤ 2.0	0.016	TO-48
K16RIA	16	2.35	48	25	200-1200	≤ 10	10-20	10-100	≤ 2.5	≤ 150	≤ 200	≥ 500	≥ 100	≤ 1.5	≤ 2.0	0.016	TO-48	
K25RIA	25	2.50	75	40	200-1200	≤ 12	10-20	50-100	≤ 2.5	≤ 150	≤ 200	≥ 500	≥ 100	≤ 1.0	≤ 2.0	0.022	TO-65	
K40RIA	40	2.55	120	64	200-1200	≤ 12	10-20	50-100	≤ 2.5	≤ 150	≤ 200	≥ 500	≥ 100	≤ 1.0	≤ 2.0	0.022	TO-65	
K50RIA	50	2.50	150	80	200-1200	≤ 12	10-20	50-100	≤ 2.5	≤ 150	≤ 200	≥ 500	≥ 100	≤ 0.8	≤ 2.0	0.022	TO-65	
KST80S	80	2.30	240	128	200-1600	≤ 15	15-25	50-100	≤ 2.5	≤ 200	≤ 400	≥ 800	≥ 100	≤ 0.6	≤ 12	0.160	TO-94	
KST100S	100	2.25	300	160	200-1600	≤ 15	15-25	50-100	≤ 2.5	≤ 200	≤ 400	≥ 800	≥ 100	≤ 0.6	≤ 12	0.160	TO-94	
KST150S	150	2.35	450	240	200-1800	≤ 20	15-30	50-100	≤ 2.5	≤ 200	≤ 400	≥ 800	≥ 100	≤ 0.5	≤ 25	0.280	TO-93	
KST180S	200	2.40	600	320	200-1800	≤ 20	15-30	50-100	≤ 2.5	≤ 400	≤ 600	≥ 800	≥ 100	≤ 0.45	≤ 25	0.280	TO-93	
KST230S	250	2.45	700	400	200-1800	≤ 25	15-30	50-100	≤ 2.5	≤ 400	≤ 600	≥ 800	≥ 100	≤ 0.3	≤ 30	0.580	TO-118	
KST300S	300	2.50	900	480	200-1800	≤ 40	15-30	50-100	≤ 2.5	≤ 400	≤ 600	≥ 800	≥ 100	≤ 0.25	≤ 30	0.580	TO-118	

Thyristor Stud Version Outline

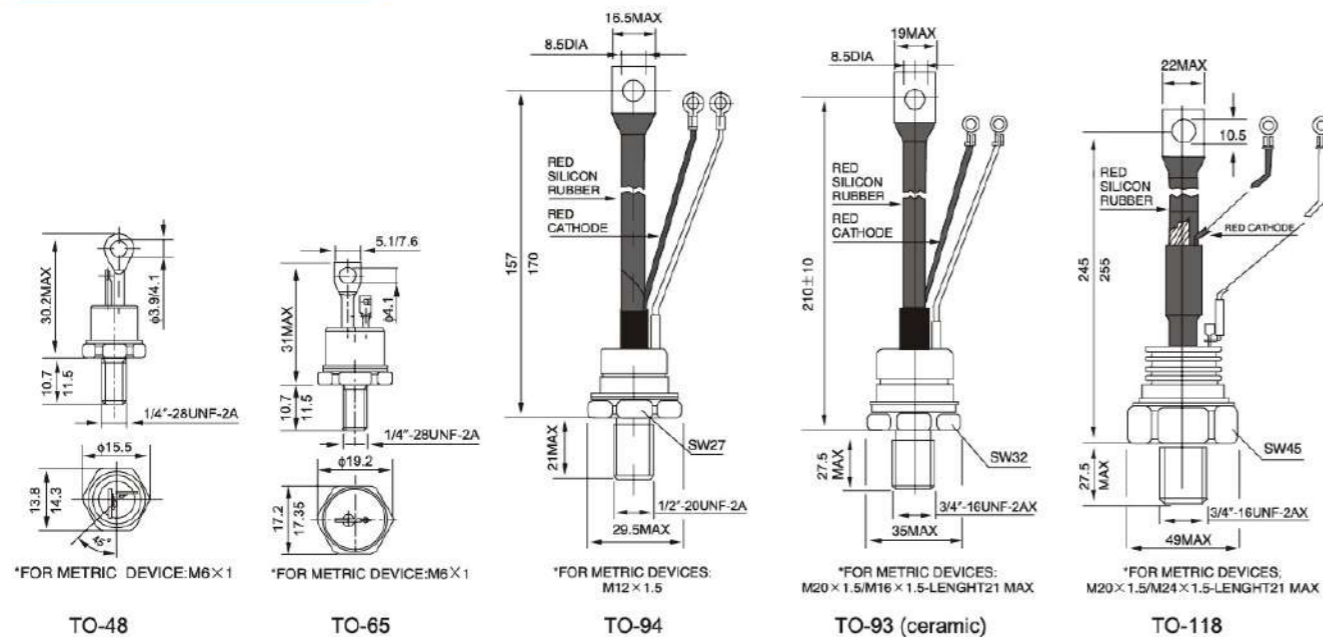

Features

- High surge current capability
- Stud cathode and stud anode version
- Wide current range
- Inch device version available

Typical Applications

- Battery charges
- Converters
- Power supplies
- Machine tool controls
- Welder
- Motor controls
- Lighting circuits

Ordering Information Table

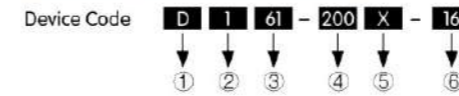

- 1 - D=Standard recovery diode DF=Fast recovery diode
- 2 - 1=Ceramic device 2=Glass-Metal device
- 3 - Device outline code
- 4 - Current code=IF(AV)
- 5 - None=Stud Reverse Polarity (anode to stud) X=Stud Normal Polarity (cathode to stud)
- 6 - Voltage code=Code x 100=VRRM

Russia Type Standard Recovery Diode (Stud Version)

Type	V _{RRM}	I _{RM}	I _{FM}	I _{FSM}	I _{FSM}	V _{TM} /I _{TM}	T _j	R _{θj-c}	M ²	WI	Outline
	V	mA	A	A	kA	V/A					
D212-10(X)	100-1200	3	10	15	0.25	1.35/31	-40°C ~ +150°C	2.700	0.9-1.1	0.006	RSD1
D212-16(X)	100-1200	3	16	25	0.27	1.35/50	2.000	0.9-1.1	0.006		
D212-25(X)	100-1200	3	25	39	0.31	1.35/78	1.250	0.9-1.1	0.006	RSD2	
D222-32(X)	100-1200	5	32	50	0.46	1.35/100	1.000	1.4-1.8	0.015		
D222-40(X)	100-1200	5	40	62	0.55	1.35/125	0.800	1.4-1.8	0.015	RSD2	
D232-50(X)	100-1600	6	50	76	1.20	1.35/157	0.600	5.0-6.2	0.027		
D232-63(X)	100-1600	6	63	96	1.40	1.35/198	0.500	5.0-6.2	0.027	RSD3	
D232-80(X)	100-1600	5	80	125	1.50	1.35/250	0.400	5.0-6.2	0.027		
D141-100(X)	100-1600	20	100	180	2.20	1.35/314	0.400	6-10	0.090	RSD4	
D151-125(X)	100-1600	20	125	195	3.00	1.35/392	0.300	10-20	0.165		
D151-160(X)	100-1600	20	160	300	4.50	1.35/502	0.240	10-20	0.165	RSD5	
D161-200(X)	100-1800	40	200	400	5.50	1.35/602	0.150	20-30	0.250		
D161-250(X)	100-1800	40	250	480	6.40	1.35/785	0.140	20-30	0.250	RSD6	
D161-320(X)	100-1800	40	320	520	7.50	1.35/1005	0.130	20-30	0.250		
D171-400(X)	100-2400	50	400	725	14.25	1.40/1256	0.085	20-30	0.465	RSD7	
D171-500(X)	100-2400	50	500	760	14.0	1.45/1500	0.080	25-35	0.465		

Russia Type Fast Thyristor (Stud Version)

Type	V_{RRM}	I_{RSM}	I_{FMV}	I_{FSM}	I_{FSM}	T_{rr}	T_c	$R_{\theta c}$	M^2	Wt	Outline	
	V	mA	A	A	kA	kA	μs	$^{\circ}C$	$^{\circ}C/W$	N/m		kg
DF112-10	400-1400	10	10	16	0.18	2.30/31	0.5	-40 $^{\circ}C$ ~ +150 $^{\circ}C$	2.50	0.9-1.1	0.006	RSD1
DF212-16	400-1400	10	16	25	0.25	2.30/50	0.5		1.60	0.9-1.1	0.006	
DF212-20	400-1400	10	20	31	0.31	2.30/62	0.5		1.20	0.9-1.1	0.006	
DF222-25	400-1400	15	25	39	0.40	2.30/78	0.5		1.00	1.4-1.8	0.015	RSD2
DF222-32	400-1400	15	32	50	0.50	2.30/98	0.5		0.80	1.4-1.8	0.015	
DF232-40	400-1400	20	40	62	0.60	2.30/125	0.7		0.60	5.0-6.2	0.027	RSD3
DF232-50	400-1400	20	50	78	0.75	2.30/157	0.7		0.50	5.0-6.2	0.027	
DF232-63	400-1400	20	63	98	0.95	2.30/198	0.7		0.40	5.0-6.2	0.027	RSD4
DF141-63	400-1400	50	63	100	2.0	2.23/198	10.2.0		0.45	6-10	0.090	
DF141-60	400-1400	30	80	125	2.5	1.58/250	4.8		0.45	6-10	0.090	RSD5
DF151-125	400-1400	30	125	200	4.0	2.04/390	2.0		0.25	10-20	0.165	
DF161-160	400-1400	20	160	250	3.5	2.45/500	3.2.4.0		0.25	20-30	0.250	RSD6
DF161-200	400-1400	20	200	300	4.3	1.85/528	3.2.4.0		0.25	20-30	0.250	
DF161-250	400-1400	30	250	390	4.5	2.71/785	3.2.4.0		0.15	20-30	0.250	RSD7
DF171-320	400-1400	30	320	500	5.3	2.13/1000	5.0.6.5	0.15	25-35	0.465		

Thyristor Stud Version Outline

Type	V_{RRM}	I_{RSM}	I_{FMV}	I_{FSM}	I_{FSM}	I_{FT}	V_{FM}/I_{FM}	T_{TO}	PRSM	r_f	T_{max}	$R_{th(j-c)}$	M^2	Wt	Outline
	V	mA	A	A	kA	A 2 S10 3	A	V	kW	m Ω	$^{\circ}C$	$^{\circ}C/W$	N/m	kg	
DL212-10	400-1600	6	10	15	0.25	0.31	1.35/31	0.90	2.5	17.5	-40 $^{\circ}C$ ~ +150 $^{\circ}C$	2.70	0.9-1.1	0.006	RSD1
DL212-16	400-1600	6	16	25	0.27	0.36	1.35/50	0.90	2.5	10.5		1.75	0.9-1.1	0.006	
DL212-25	400-1600	6	25	39	0.34	0.58	1.35/78	0.90	2.5	6.10		1.10	0.9-1.1	0.006	
DL222-32	400-1600	8	32	50	0.46	1.06	1.35/100	0.85	3.0	5.00		0.95	1.4-1.8	0.012	RSD2
DL222-40	400-1600	8	40	62	0.55	1.51	1.35/125	0.85	3.0	4.00		0.80	1.4-1.8	0.012	
DL232-50	400-1600	10	50	78	12	72	1.35/157	0.83	5.0	3.10		0.60	5.0-6.2	0.027	RSD3
DL232-63	400-1600	10	63	98	14	98	1.35/198	0.83	5.0	2.80		0.50	5.0-6.2	0.027	
DL232-80	400-1600	10	80	125	15	11.25	1.35/250	0.83	5.0	2.10		0.40	5.0-6.2	0.027	RSD4
DL141-100	400-1600	15	100	150	2.2	24	1.35/314	0.95	25	1.60		0.40	6-10	0.090	
DL151-160	400-1600	15	150	220	4.5	45	1.35/392	0.95	25	1.30		0.30	10-20	0.165	RSD5
DL161-200	400-1600	25	200	300	5.5	100	1.35/600	0.90	16	0.85		0.25	20-30	0.265	
DL161-250	400-1600	25	250	375	6.4	150	1.35/750	0.90	16	0.75		0.15	20-30	0.265	RSD6
DL171-320	400-1600	25	320	450	7.5	200	1.35/900	0.90	16	0.65		0.13	20-35	0.460	
DL171-400	400-1600	25	400	600	9.25	280	1.35/1200	0.90	16	0.55		0.095	20-35	0.460	RSD7

Russia Type Diode Stud Version Outline

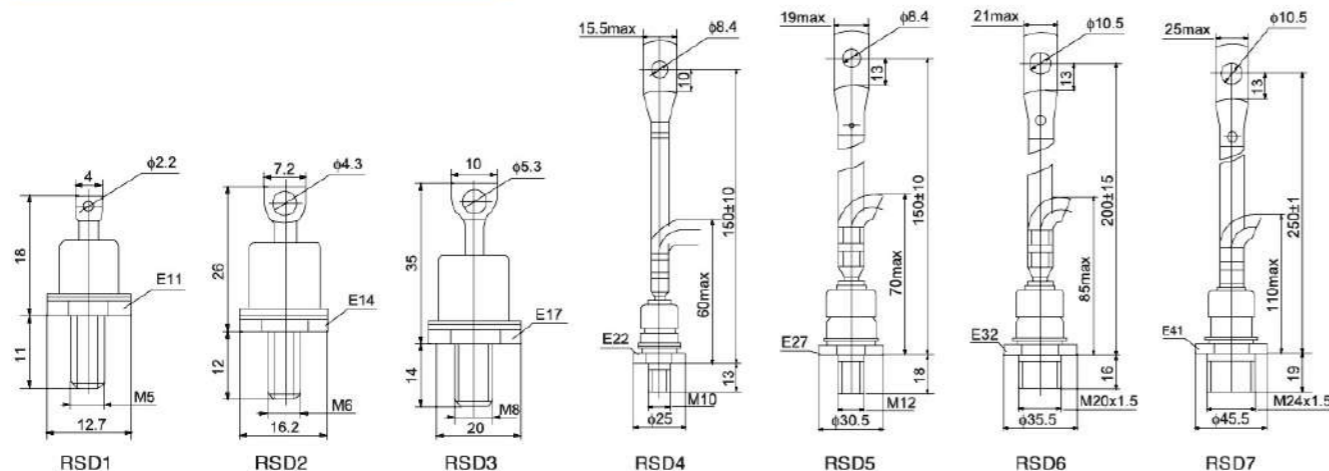

Features

- High surge current capability
- Stud cathode and stud anode version
- Wide current range
- Inch device version available

Typical Applications

- Battery charges
- Converters
- Power supplies
- Machine tool controls
- Welder
- Motor controls
- Lighting circuits

Ordering Information Table

Device Code: **TC 1 61 - 200 - 16**

① ② ③ ④ ⑤

1 - T=Phase control thyristor
TB=Fast thyristor TC=Triac thyristor
2 - 1=Ceramic device
2=Glass-Metal device

3 - Device outline code
4 - Current code=IT(AV)
5 - Voltage code=Code x 100=VRRM

Russia Type Phase Control Thyristor (Stud Version)

Type	V_{RRM}	I_{RSM}	I_{FMV}	I_{FSM}	I_{FSM}	V_{FM}/I_{FM}	d_v/d_i	d_c/d_i	V_{GT}	I_{GT}	I_{HT}	T_c	$R_{\theta c}$	T_{rr}	M^2	Wt	Outline
	V	mA	A	A	kA	V/A	A/ μs	V/ μ	mA	mA	mA	$^{\circ}C$	$^{\circ}C/W$	μs	N/m	kg	
T212-10	100-1300	3	10	15.7	0.15	1.93/31	125	50-500	3.0	40	5-50	-40 $^{\circ}C$ ~ +125 $^{\circ}C$	1.80	63	0.9-1.1	0.006	RST1
T212-16	100-1300	3	15	25.2	0.24	1.80/50	125	50-500	3.0	40	5-50		1.50	63	0.9-1.1	0.006	
T222-20	100-1300	3.5	20	31.4	0.30	1.75/63	125	50-500	3.0	60	5-50		0.90	63	1.4-1.8	0.015	
T222-25	100-1300	3.5	25	39.2	0.35	1.75/78	125	50-500	3.0	60	5-50		0.80	63	1.4-1.8	0.015	RST2
T232-25	1200-1600	9	25	30.2	0.33	2.20/78	125	50-500	3.5	100	5-100		0.80	160	5.0-6.2	0.023	
T232-40	100-1300	5	40	62.8	0.75	1.75/125	125	50-500	4.0	100	5-100		0.62	63	5.0-6.2	0.023	RST3
T232-50	100-1300	5	50	70.5	0.80	1.75/157	125	50-500	4.0	100	5-100		0.50	63	5.0-6.2	0.023	
T242-50	1200-1600	15	50	78.5	0.85	2.10/157	125	50-500	3.5	120	5-100		0.40	160	9.0-11	0.050	RST4
T242-63	100-1300	7	63	90.9	1.30	1.65/108	125	50-500	4.0	150	5-100		0.40	63	9.0-11	0.050	
T242-80	100-1300	7	80	125.8	1.50	1.63/250	125	50-500	4.0	150	5-100		0.30	63	9.0-11	0.050	RST5
T151-100	300-1600	15	100	160	2.0	1.80/314	160	200-1000	3.5	200	5-200		0.15	160	10-20	0.165	
T151-125	300-1600	15	125	200	2.5	1.75/392	125	200-1000	3.5	200	5-200		0.15	160	20-30	0.165	RST6
T161-160	300-1800	15	160	260	4.0	1.70/502	125	200-1000	3.5	200	5-200		0.15	160	20-30	0.250	
T161-200	300-1800	15	200	315	5.0	1.80/628	160	200-1000	3.5	200	5-200		0.13	250	20-30	0.250	RST7
T161-250	300-1600	30	250	390	5.0	1.85/780	125	200-1000	3.5	200	5-200	0.10	160	20-30	0.250		
T171-250	300-1800	30	250	393	6.0	1.75/785	125	200-1000	3.5	200	5-200	0.10	160	25-35	0.440	RST7	
T171-320	300-1800	30	320	500	8.5	1.60/1005	320	200-1000	3.5	200	5-200	0.85	160	25-35	0.440		

Russia Type Fast Thyristor (Stud Version)

Type	V_{RRM}	I_{TSM}	I_{TAV}	I_{TSM}	I_{TSM}	V_{TM}/I_{TM}	d_1/d_2	d_1/d_3	V_{GT}	I_{GT}	I_{T1}	T_c	$R_{c/w}$	T_{11}	M^2	WI	Outline
	V	mA	A	A	kA	V/A	A/ μ S	V/ μ	mA	mA	mA	$^{\circ}$ C	$^{\circ}$ C/W	μ S	N/m	kg	
TB212-10	400-1400	10	10	16	0.15	2.2/31	200	100-1000	2.0	100	5-50	-40 $^{\circ}$ C	1.50	12.5,20,25,32	0.9-1.1	0.006	RST1
TB222-16	400-1400	12	16	25	0.30	2.2/50	200	100-1000	2.0	120	5-50	-	0.90	12.5,20,25,32	1.5-1.7	0.015	RST2
TB222-20	400-1400	12	20	31	0.35	2.2/62	200	100-1000	2.0	120	5-50	-	0.80	12.5,20,25,32	1.5-1.7	0.015	RST2
TB232-25	400-1400	15	25	39	0.50	2.2/78	200	100-1000	2.5	170	5-100	-	0.82	12.5,20,25,32	5.0-8.2	0.023	RST3
TB232-32	400-1400	15	32	50	0.60	2.2/99	200	100-1000	2.5	170	5-100	-	0.62	12.5,20,25,32	5.0-6.2	0.023	RST3
TB232-40	400-1400	15	40	62	0.75	2.2/125	200	100-1000	2.5	170	5-100	-	0.50	12.5,20,25,32	5.0-6.2	0.023	RST3
TB242-50	400-1400	20	50	78	1.00	2.2/157	200	100-1000	3.0	200	5-100	-40 $^{\circ}$ C	0.40	12.5,20,25,32	9.0-1.1	0.050	RST4
TB242-63	400-1400	20	63	98	1.10	2.2/198	200	100-1000	3.0	200	5-100	-	0.30	12.5,20,25,32	9.0-1.1	0.050	RST4
TB151-80	500-1600	20	80	126	1.6	2.2/250	500	500-1000	3.0	250	5-200	+125 $^{\circ}$ C	0.25	20,25,32,40	10-20	0.165	RST5
TB151-100	500-1600	20	100	157	2.0	1.8/314	500	500-1000	2.5	250	5-200	-	0.25	20,25,32,40	10-20	0.165	RST5
TB161-125	500-1600	25	125	198	3.5	2.2/390	500	500-1000	2.5	250	5-200	-	0.15	20,25,32,40	20-30	0.250	RST6
TB161-160	500-1600	25	160	250	4.0	1.8/500	500	500-1000	2.5	250	5-200	-	0.15	20,25,32,40	20-30	0.250	RST6
TB171-200	500-1600	35	200	314	6.0	2.2/630	500	500-1000	3.5	250	5-200	-	0.10	20,25,32,40	25-35	0.440	RST7
TB171-250	500-1600	35	250	302	7.0	1.8/785	500	500-1000	3.5	250	5-200	-	0.10	20,25,32,40	25-35	0.440	RST7
TB171-320	500-1600	35	320	390	8.0	2.2/900	500	500-1000	3.5	250	5-200	-	0.10	20,25,32,40	25-35	0.440	RST7

Russia Type Triac Thyristor (Stud Version)

Type	V_{RRM}	I_{TSM}	I_{TAV}	I_{TSM}	V_{TM}/I_{TM}	d_1/d_2	d_1/d_3	V_{GT}	I_{GT}	I_{T1}	T_c	$R_{c/w}$	M^2	WI	Outline
	V	mA	A	kA	V/A	A/ μ S	V/ μ	mA	mA	mA	$^{\circ}$ C	$^{\circ}$ C/W	N/m	kg	
TC212-10	200-1200	3.0	10	0.07	1.85/14	5.0	2.2-25	2.0	3.0	5-50	-40 $^{\circ}$ C	2.50	0.9-1.1	0.006	RST1
TC212-16	200-1200	3.0	16	0.10	1.85/22	5.0	2.5-25	2.0	3.0	5-50	-	1.55	0.9-1.1	0.006	RST1
TC222-20	200-1200	3.5	20	0.12	1.85/29	5.0	2.5-50	2.5	3.5	5-50	-	1.30	1.5-1.7	0.015	RST2
TC222-25	200-1200	3.5	25	0.20	1.80/35	5.0	2.5-50	2.5	3.5	5-50	-	0.90	1.5-1.7	0.015	RST2
TC232-40	200-1200	5.0	40	0.25	1.85/58	6.3	6.3-100	3.0	4.0	50-100	-	0.65	5.0-6.2	0.023	RST3
TC232-50	200-1200	5.0	50	0.45	1.80/70	6.3	6.3-100	3.0	4.0	50-100	-	0.52	5.0-6.2	0.023	RST3
TC242-63	200-1200	7.0	63	0.40	1.80/89	6.3	6.3-100	3.0	5.0	50-100	-40 $^{\circ}$ C	0.44	9.0-1.1	0.050	RST4
TC242-80	200-1200	7.0	80	0.50	1.80/113	6.3	6.3-100	3.0	5.0	50-100	-	0.34	9.0-1.1	0.050	RST4
TC151-100	200-1200	10	100	1.0	1.65/140	6.3	6.3-100	3.0	300	50-100	+125 $^{\circ}$ C	0.22	10-20	0.165	RST5
TC151-125	200-1200	10	125	1.2	1.74/180	6.3	6.3-100	3.0	300	50-100	-	0.22	10-20	0.165	RST5
TC161-160	200-1600	15	160	1.8	1.75/225	6.3	6.3-100	3.0	300	50-200	-	0.14	20-30	0.250	RST6
TC161-200	200-1600	15	200	2.0	1.60/290	6.3	6.3-100	3.5	300	50-200	-	0.14	20-30	0.250	RST6
TC171-250	200-1600	25	250	3.0	1.70/350	25	6.3-100	3.5	300	50-200	-	0.10	25-35	0.440	RST7
TC171-320	200-1600	25	320	3.3	1.50/450	25	6.3-100	3.5	300	50-200	-	0.10	25-35	0.440	RST7

Russia Type Thyristor Stud Version Outline

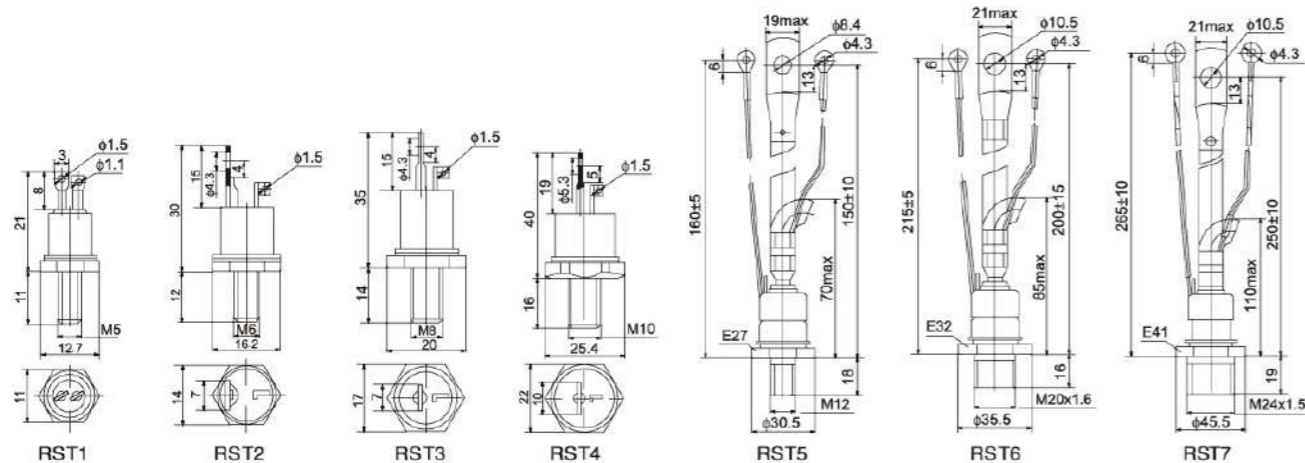

Features

- High surge current capability
- Stud cathode and stud anode version
- Wide current range
- Inch device version available

Typical Applications

- Machine tool controls
- Battery charges
- Converters
- Motor controls
- Welder
- Phase control applications in converters
- Lighting circuits

Ordering Information Table

Device Code

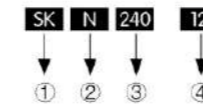

- 1** SEMIKRON - Type Semiconductor
- 2** - N=anode to stud (stud reverse polarity)
R=cathode to stud (stud normal polarity)
T=phase control thyristor

- 3** - Current code=IT(AV) or IF(AV)
- 4** - Voltage code=Code x 100=VRRM

Notice: If you need inch size or ceramic type, pls contact ECC.

SEMIKRON Type Standard Recovery Diode (Stud Version)

Type	I_{FSM}	V_{RM}/I_{RM}		I_{TSM}	V_{RRM}	I_{TSM}	$R_{c/w}$	T_c	M^2	WI	Outline
	A	V	A	A	V	mA	$^{\circ}$ C/W	$^{\circ}$ C	N/m	kg	
SKN26	25	1.25	75	40	200-1200	≤ 12	≤ 1.2	-40 $^{\circ}$ C	≤ 1.0	0.010	SKD4
SKR26	25	1.25	75	40	200-1200	≤ 12	≤ 1.2	-	≤ 1.0	0.010	
SKN46	45	1.4	135	75	200-1600	≤ 10	≤ 1.0	-	≤ 2.0	0.025	SKD5
SKR46	45	1.4	135	75	200-1600	≤ 10	≤ 1.0	-	≤ 2.0	0.025	
SKN71	70	1.45	210	115	200-1600	≤ 12	≤ 0.8	-	≤ 2.0	0.025	SKD5
SKR71	70	1.45	210	115	200-1600	≤ 12	≤ 0.8	-	≤ 2.0	0.025	
SKN45	45	1.4	135	75	200-1600	≤ 10	≤ 1.0	-	≤ 2.0	0.050	SKD5L
SKR45	45	1.4	135	75	200-1600	≤ 10	≤ 1.0	-	≤ 2.0	0.050	
SKN70	70	1.45	110	115	200-1600	≤ 12	≤ 0.8	-40 $^{\circ}$ C	≤ 2.0	0.050	SKD5L
SKR70	70	1.45	210	115	200-1600	≤ 12	≤ 0.8	-	≤ 2.0	0.050	
SKN100	100	1.6	300	160	200-1600	≤ 15	≤ 0.5	+125 $^{\circ}$ C	≤ 12	0.120	SKD8
SKR100	100	1.6	300	160	200-1600	≤ 15	≤ 0.5	-	≤ 12	0.120	
SKN130	130	1.5	390	210	200-1600	≤ 15	≤ 0.4	-	≤ 12	0.120	SKD8
SKR130	130	1.5	390	210	200-1600	≤ 15	≤ 0.4	-	≤ 12	0.120	
SKN240	240	1.35	720	400	200-1800	≤ 15	≤ 0.2	-	≤ 25	0.240	SKD9
SKR240	240	1.35	720	400	200-1800	≤ 15	≤ 0.2	-	≤ 25	0.240	
SKN320	320	1.5	960	210	200-1800	≤ 20	≤ 0.1	-	≤ 30	0.450	SKD10
SKR320	320	1.5	960	210	200-1800	≤ 20	≤ 0.1	-	≤ 30	0.450	
SKN400	400	1.6	1200	640	200-2400	≤ 20	≤ 0.1	-	≤ 30	0.450	SKD10
SKR400	400	1.6	1200	640	200-2400	≤ 20	≤ 0.1	-	≤ 30	0.450	

SEMIKRON Type Phase Control Thyristor (Stud Version)

Type	IF (AV)		VFM/IFM		IT (RMS)	VDRM	ITRM	IGT	VGT	I ₁	I ₂	d ₁ /d ₂	d ₁ /d ₁	T _J	R _{θc}	M ²	Wt	Outline
	T _{HS} 55°C		25°C															
	A	V	A	A	V	mA	mA	V	mA	mA	mA	mA	°C	°C/W	N/m	kg		
SKT10	10	1.75	30	16	200-1200	≤ 10	10-100	≤ 2.5	≤ 150	≤ 200	≥ 500	≥ 100		≤ 1.8	≤ 2.0	0.016		SKT4
SKT16	16	1.75	48	25	200-1200	≤ 10	10-100	≤ 2.5	≤ 150	≤ 200	≥ 500	≥ 100		≤ 1.5	≤ 2.0	0.016		
SKT24	25	1.7	75	40	200-1200	≤ 10	10-100	≤ 2.5	≤ 150	≤ 200	≥ 500	≥ 100		≤ 1.5	≤ 2.0	0.016		SKT5
SKT40	40	1.95	120	64	200-1200	≤ 12	10-100	≤ 2.5	≤ 150	≤ 200	≥ 500	≥ 100		≤ 1.0	≤ 2.0	0.025		
SKT50	50	1.9	150	80	200-1200	≤ 12	10-100	≤ 2.5	≤ 150	≤ 200	≥ 500	≥ 100		≤ 1.0	≤ 2.0	0.025		SKT8
SKT55	55	1.6	180	90	200-1600	≤ 15	50-100	≤ 2.5	≤ 200	≤ 400	≥ 800	≥ 100	-40°C ~ +125°C	≤ 0.8	≤ 12	0.120		
SKT80	80	1.6	240	128	200-1600	≤ 15	50-100	≤ 2.5	≤ 200	≤ 400	≥ 800	≥ 100		≤ 0.8	≤ 12	0.120		SKT9
SKT100	100	1.6	300	160	200-1600	≤ 15	50-100	≤ 2.5	≤ 200	≤ 400	≥ 800	≥ 100		≤ 0.8	≤ 12	0.120		
SKT130	130	1.55	390	208	200-1800	≤ 20	50-100	≤ 2.5	≤ 200	≤ 400	≥ 800	≥ 100		≤ 0.6	≤ 25	0.240		SKT10
SKT160	160	1.75	500	250	200-1800	≤ 20	50-100	≤ 2.5	≤ 200	≤ 400	≥ 800	≥ 100		≤ 0.6	≤ 25	0.240		
SKT200	200	1.75	600	320	200-1800	≤ 20	50-100	≤ 2.5	≤ 400	≤ 600	≥ 800	≥ 100		≤ 0.6	≤ 25	0.240		SKT10
SKT250	250	1.55	750	450	200-2400	≤ 30	50-100	≤ 2.5	≤ 400	≤ 600	≥ 800	≥ 100		≤ 0.4	≤ 30	0.450		
SKT300	300	1.50	900	500	200-2400	≤ 30	50-100	≤ 2.5	≤ 200	≤ 400	≥ 800	≥ 100		≤ 0.4	≤ 30	0.450		

SEMIKRON Type Stud Version Outline

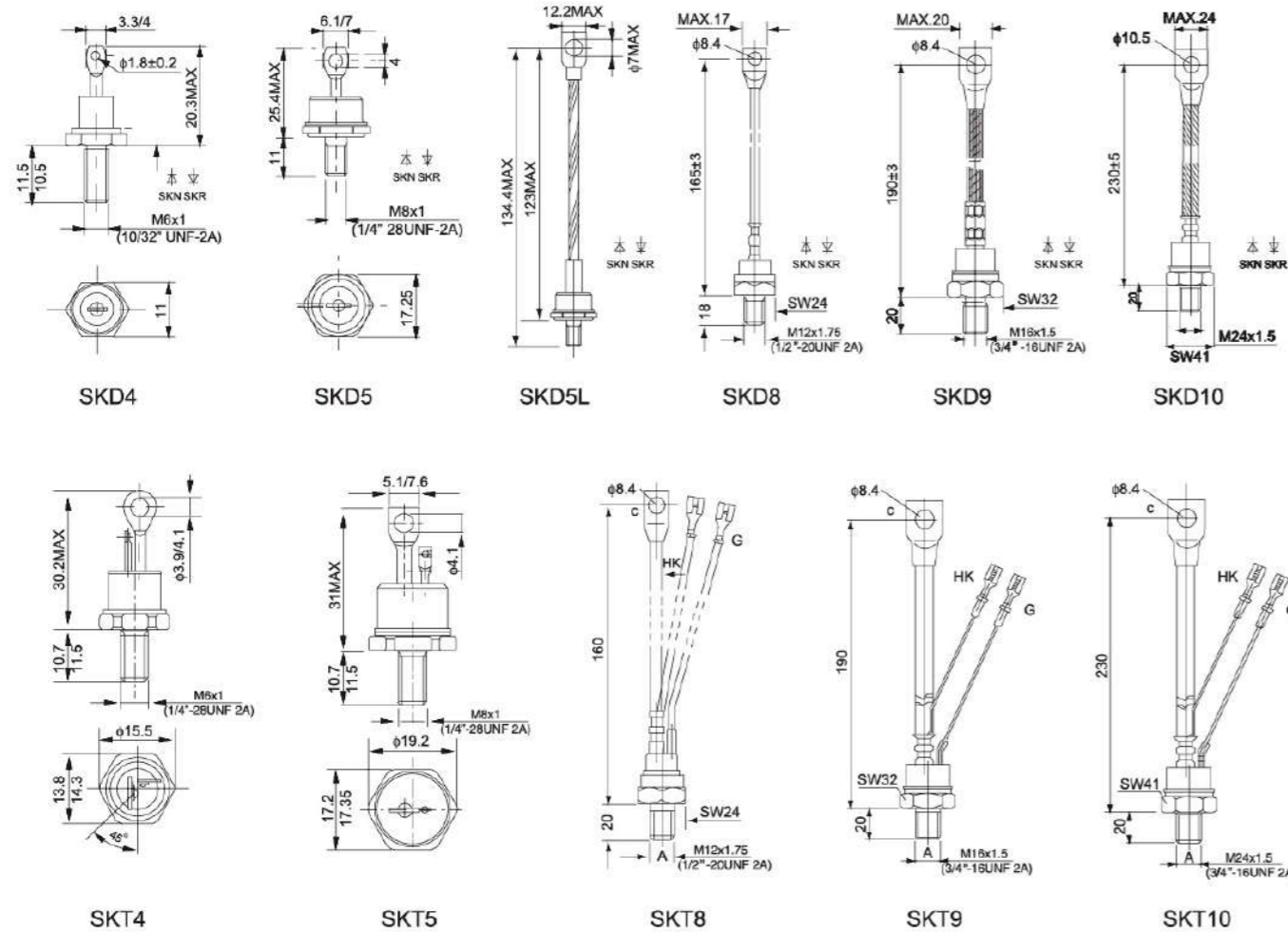

Chinese Type Standard Recovery Diode (stud Version)

Features

- High surge current capability
- Stud cathode and stud anode version
- Wide current range

Typical Applications

- Battery charges
- Converters
- Power supplies
- Machine tool controls
- Welder
- Motor controls

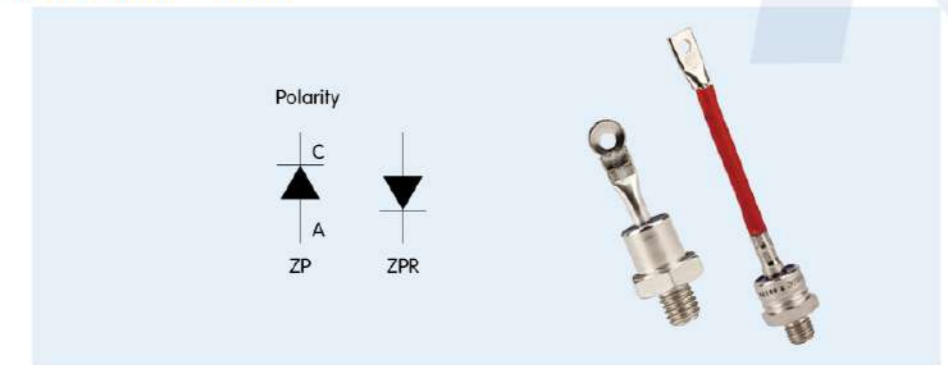

Type	IF (AV)		VFM	VDRM	ITRM	R _{θc}	T _J	Wt	Outline	Heatsink
	T _{HS} 55°C	25°C								
	A	A	V	V	mA	°C/W	°C	kg		
ZP5A	5	7.9	≤ 1.6	200-2000	≤ 2	≤ 4.0	-40°C ~ +150°C	0.010	A1	SZ13
ZP10A	10	16	≤ 1.6	200-2000	≤ 2	≤ 2.5		0.025	A2	SZ14
ZP20A	20	31	≤ 1.6	200-2000	≤ 6	≤ 1.4		0.027	A3/C1	SZ15
ZP30A	30	47	≤ 1.6	200-2000	≤ 6	≤ 1.0		0.110	C2	SZ16
ZP50A	50	79	≤ 1.6	200-2000	≤ 12	≤ 0.6		0.140	C3	SZ16
ZP100A	100	160	≤ 1.8	200-2000	≤ 12	≤ 0.3		0.205	C4	SL17
ZP200A	200	310	≤ 1.8	200-3000	≤ 12	≤ 0.2		0.325	C5	SL18
ZP300A	300	470	≤ 1.8	200-3000	≤ 15	≤ 0.11		0.470	C6	SL19
ZP400A	400	550	≤ 1.8	200-5000	≤ 15	≤ 0.075		0.750	C7	SL20
ZP500A	500	630	≤ 1.8	200-5000	≤ 15	≤ 0.068		0.925	C7/C8	SL20

Chinese Type Phase Control Thyristor (stud Version)

Features

- High current rating
- Excellent dynamic characteristics
- Superior surge capabilities
- Standard package

Typical Applications

- Phase control applications in converters
- Lighting circuits
- Battery charges
- Regulated power supplies and temperature and speed control circuit
- Can be supplied to meet stringent military, aerospace and other high-reliability requirements
- Power supplier & motor controls



Type	IT (RMS)		VFM	VDRM	ITRM	IGT	VGT	I _H	d ₁ /d ₂	d ₁ /d ₁	T _J	R _{θc}	Wt	Outline	Heatsink
	T _{HS} 55°C	25°C													
	A	A	V	V	mA	mA	V	mA	V/μS	A/μS	°C	°C/W	kg		
KP5A	5	8	≤ 2.2	200-2000	≤ 8	5-45	≤ 2.5	5-45	≥ 500	/	-40°C ~ +125°C	≤ 3.0	0.012	B1	SZ13
KP10A	10	16	≤ 2.2	200-2000	≤ 8	5-45	≤ 2.5	5-45	≥ 500	/		≤ 2.5	0.027	B2	SZ14
KP20A	20	32	≤ 2.2	200-2000	≤ 8	5-45	≤ 2.5	5-45	≥ 500	/		≤ 1.0	0.029	B3/D1	SZ15
KP30A	30	48	≤ 2.2	200-2000	≤ 10	5-50	≤ 2.5	5-50	≥ 800	100		≤ 0.5	0.112	D2	SZ16
KP50A	50	80	≤ 2.4	200-2000	≤ 10	5-150	≤ 2.5	5-150	≥ 800	100		≤ 0.14	0.142	D3	SZ16
KP100A	100	160	≤ 2.4	200-2000	≤ 10	5-200	≤ 2.5	5-200	≥ 800	100		≤ 0.11	0.207	D4	SL17
KP200A	200	320	≤ 2.6	200-2000	≤ 10	5-200	≤ 2.5	5-200	≥ 800	100		≤ 0.11	0.327	D5	SL18
KP300A	300	480	≤ 2.6	200-2000	≤ 30	5-200	≤ 2.5	5-200	≥ 800	100		≤ 0.08	0.472	D6	SL19
KP400A	400	550	≤ 2.6	200-3000	≤ 30	5-200	≤ 2.5	5-200	≥ 800	100		≤ 0.05	0.750	D7	SL20
KP500A	500	800	≤ 2.6	200-3000	≤ 30	5-200	≤ 2.5	5-200	≥ 800	100		≤ 0.04	0.927	D7/D8	SL20

Chinese Type Triac Thyristor (stud Version)

Features

- High current rating
- Excellent dynamic characteristics
- Superior surge capabilities
- Standard package

Typical Applications

- Phase control applications in converters
- Lighting circuits
- Battery charges
- Regulated power supplies and temperature and speed control circuit
- Can be supplied to meet stringent military, aerospace and other high-reliability requirements
- Power supplier & motor controls



Type	IFSM (A)		VSM (V)	VDRM (V)	IDRM (mA)	IGT (mA)	IH (mA)	VGT (V)	d _v /d _t (V/μs)	d/d _t (A/μs)	T _J (°C)	R _{θJC} (°C/W)	WI (kg)	Outline	Heatsink
	T ₁₀₀ 55°C	25°C													
K85A	5	≤ 2.6	200-2000	≤ 30	≤ 350	≤ 250	3.5	≤ 500	≤ 10	-40°C ~ +125°C	0.11	0.010	B1	SZ13	
KS10A	10	≤ 2.6	200-2000	≤ 30	≤ 350	≤ 250	3.5	≤ 500	≤ 10		0.11	0.025	B2	SZ14	
KS20A	20	≤ 2.6	200-2000	≤ 30	≤ 350	≤ 250	3.5	≤ 500	≤ 10		0.11	0.027	B3	SZ15	
KS30A	30	≤ 2.6	200-2000	≤ 30	≤ 350	≤ 250	3.5	≤ 500	≤ 10		0.11	0.110	D2	SZ16	
KS50A	50	≤ 2.6	200-2000	≤ 30	≤ 350	≤ 250	3.5	≤ 500	≤ 10		0.11	0.130	D3	SZ16	
KS100A	100	≤ 2.6	200-2000	≤ 30	≤ 350	≤ 250	3.5	≤ 500	≤ 10		0.11	0.165	D4	SL17	
KS200A	200	≤ 2.6	200-2000	≤ 30	≤ 350	≤ 250	3.5	≤ 500	≤ 10		0.11	0.335	D5	SL18	

Chinese Type Stud Version Outline List

Type	Outline No.	Dimension (mm)					
		d	D	L	h	φ1	φ2
50A	A1 B1	6	16	29	10	3	2
10A	A2 B2	8	22	39	13	4	2
20A	A3 B3	10	22	39	13	4	2
20A(L)	C1 D1	10	27	180	13	6	2
30A	G2 D2	12	32	170	15	6.5	5
50A	C3 D3	12	36	175	15	6.5	5
100A	C4 D4	16	36	200	16	8	5
200A	C5 D5	20	43	225	20	9	5
300A	C6 D6	20	49	240	20	9	5
400A/500A	C7 D7	30	57	300	26	15	5
500A	C8 D8	30	74	390	30	15	5

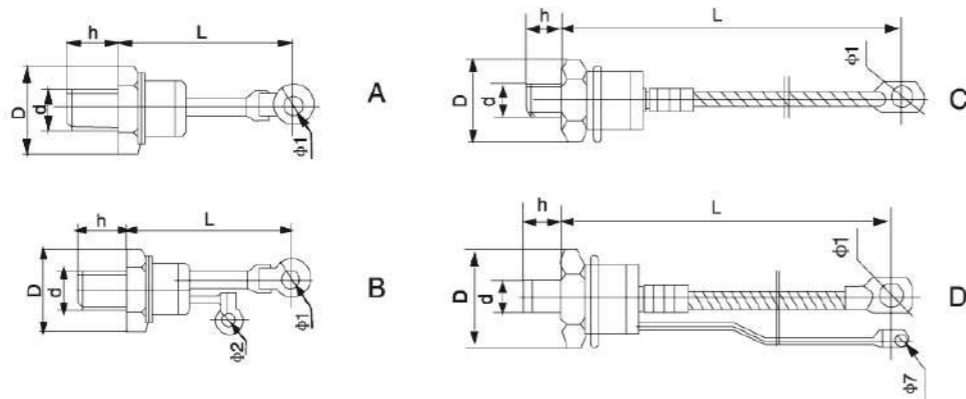

Features

- All diffuse technics
- Ceramic disc type seal
- Bifacial cooled

Typical Applications

- Big power transformer
- Welder
- Charger
- Motor control

Ordering Information Table

Device Code: SD 300 C 16 C

① ② ③ ④ ⑤

- 1 - SD=Standard recovery diode ZK=Fast recovery diode ZE=Welder class diode
- 2 - Current code=IF(AV)
- 3 - C=capsule version
- 4 - Voltage code=Code x 100=VRRM
- 5 - C=capsule case(A-puk)&(E-puk) L=capsule case (B-puk) K=capsule case(K-puk) R=capsule case(R-puk)



Notice:For other different outline, pls contact ECC.

Type	VRRM	IF(AV)	I _{FSM}	V _{IF/IFM}	R _{TH(j-c)}	T _{jm}	M ₂	Outline
	V	T ₁₀₀ 55°C A	mA	25°C V/A	°C/W	°C	KN	
SD200C	200-3000	200	16	1.8/600	0.090	150	3.3-5.5	E1/E2
SD300C	200-3000	300	30	1.8/900	0.065	150	5.3-10	E1/E2
SD400C	200-3000	400	40	1.8/1200	0.040	150	10-20	E1/E2
SD500C	200-5000	500	40	1.8/1500	0.040	150	10-20	E2/E3/E5
SD600C	200-5000	600	40	1.8/1800	0.033	150	10-20	E3/E5
SD800C	200-5000	800	80	2.2/2400	0.022	150	19-26	E5/E6
SD1000C	200-5000	1000	80	2.0/3000	0.022	150	19-26	E5/E6/E8
SD1200C	200-5000	1200	120	2.2/3000	0.020	150	21-30	E8
SD1500C	200-5000	1500	120	2.0/3000	0.020	150	21-30	E8/E9
SD2000C	200-5000	2000	160	2.2/4000	0.016	150	30-40	E11/E12/E13
SD2500C	200-5000	2500	200	2.2/5000	0.011	150	35-47	E11/E12/E13
SD3000C	200-5000	3000	160	2.0/5000	0.016	150	30-40	E11/E12/E13
SD3500C	200-5000	3500	200	2.0/5000	0.011	150	35-47	E14/E15
SD4000C	200-5000	4000	200	2.0/5000	0.009	150	70-85	E14/E15
SD5000C	200-5000	5000	200	2.5/5000	0.0135	170	70-85	E14/E15

Fast Recovery Diode (Capsule Version)

Features

- All diffuse technics
- Short recovery time
- Very small anti recovery charge
- Fast soft recovery features
- Ceramic disc type seal
- Bifacial cooled

Typical Applications

- Motor control
- Induction warm-up
- UPS power
- Charger
- Welder

Explanation

- I₂=I_{2FSM} × tw/2; tw=Half sine wave current, when at 50Hz, I₂t=0.005I_{2FSM}(A2S)FSM
- When at 60Hz, I₂t(8.3ms)=I_{2FSM}(10ms) × 1.066, T_J-T_{jm}
- I₂t(8.3ms)=I₂t(10ms) × 0.943, T_J=T_{jm}



Type	VRRM	IF(AV)	Trr	Qrr	IFSM	I _{FSM}	V _{IF/IFM}	R _{TH(j-c)}	T _{jm}	M ₂	Outline
	V	T ₁₀₀ 55°C A	100°C μs	μC	KA	mA	25°C V/A	°C/W	°C	KN	
ZK200C	200-3000	200	2	70	2.7	16	2.2/600	0.090	150	3.3-5.5	E1/E2
Zk300C	200-3000	300	3	100	4.1	30	2.4/900	0.065	150	5.3-10	E2
ZK400C	200-3000	400	3	100	5.4	40	2.4/1200	0.040	150	10-20	E2/E3/E5
ZK500C	200-3000	500	3	120	8	40	2.4/1800	0.033	150	10-20	E2/E3/E5
ZK800C	200-3000	800	3	130	10	40	2.6/2400	0.033	150	10-20	E5/E6/E8
ZK1000C	200-3000	1000	4	150	13	50	2.6/3000	0.030	150	15-20	E8



Features

- All diffuse technics
- Ceramic disc type seal
- Middle trigger
- Bifacial cooled
- High current

Typical Applications

- Big power transformer
- AC & DC motor control
- AC & DC switch
- Phase control rectification
- Inverter

Explanation

- I_{GT}, V_{GT}, I_H are all $T_A=25^\circ\text{C}$ test data, others are all $T_A=T_{jm}$ test data
- $I^2t = I_{TSM}^2 \times tw / 2; tw = \text{Half sine wave current, when at 50Hz, } I^2t = 0.005 I_{TSM}^2 (\text{A}^2\text{S})$
- When at 60Hz, $I_{TSM}(8.3\text{ms}) = I_{TSM}(10\text{ms}) \times 1.066, T_j = T_{jm}$
- $I^2t(8.3\text{ms}) = I^2t(10\text{ms}) \times 0.943, T_j = T_{jm}$

Ordering Information Table

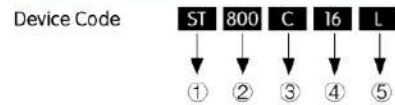

- 1** - ST=Standard thyristor
SST=Triac thyristor
KST=Fast thyristor
KE=Weledr thyristor
GTO=High frequency thyristor
- 2** - Current code=IF(AV)
- 3** - C=capsule version
- 4** - Voltage code=Code x 100=VRRM
- 5** - C=capsule case(A-puk)&(E-puk) L=capsule case (B-puk)
K=capsule case(K-puk) R=capsule case(R-puk)

Notice:For other different outline, pls contact ECC.

Type	$V_{CRM}V_{RRM}$	I_{TSM}	I_{TSM}	d_v/d_i	d_v/d_i	I_{DM}/I_{TSM}	I_{GT}	V_{GT}	I_H	V_{GM}/I_{TSM}	$R_{\theta(j-c)}$	T_{jm}	M^2	Outline
	V	A	kA	V/ μ S	A/ μ S	mA	mA	V	mA	V/A	$^\circ\text{C}/\text{W}$	$^\circ\text{C}$	KN	
ST200C	200-3000	200	2.5	300	100	30	35-250	0.8-2.0	20-150	2.4/600	0.065	125	5.3-10	E1/E2
ST300C	100-3000	300	3.8	300	100	30	35-250	0.8-2.5	20-200	2.2/900	0.055	125	5.3-10	E1/E2
ST400C	200-3000	400	5	300	100	40	35-250	0.8-2.5	20-200	2.4/1200	0.040	125	10-20	E1/E2
ST500C	200-5000	500	6.4	300	100	50	35-250	0.8-2.5	20-250	2.4/1500	0.035	125	15-20	E2/E3/E5
ST600C	200-5000	600	6.4	300	100	40	35-300	0.8-2.5	20-250	1.8/1800	0.035	125	10-20	E2/E3/E5
ST800C	200-5000	800	10	300	100	50	40-300	0.8-3.0	20-250	2.2/2400	0.032	125	15-20	E5/E6
ST1000C	200-5000	1000	13	500	150	80	40-300	0.8-3.0	20-300	2.4/3000	0.022	125	21-30	E6/E8
ST1200C	200-5000	1200	15	500	200	120	40-300	0.8-3.0	20-300	2.4/3000	0.020	125	21-30	E8
ST1500C	100-5000	1500	20	500	200	120	40-300	0.8-3.0	20-300	2.4/3000	0.017	125	27-34	E8/E9
ST1800C	200-5000	1800	22.5	500	200	160	40-300	0.8-3.0	20-300	2.4/4000	0.016	125	30-40	E11/E12/E13
ST2000C	200-5000	2000	25	500	250	200	40-300	0.8-3.0	20-300	2.4/4000	0.011	125	35-47	E11/E12/E13
ST2500C	200-5000	2500	31	500	250	200	40-300	0.8-3.0	20-300	2.4/5000	0.011	125	35-47	E11/E-12/E13
ST3000C	200-5000	3000	38	500	250	200	40-300	0.8-3.0	20-300	2.2/5000	0.011	125	35-47	E14/E15
ST3500C	200-5000	3500	44	500	250	250	40-300	0.8-3.0	20-300	2.4/5000	0.01	125	70-85	E14/E15
ST4000C	200-5000	4000	48	500	250	250	40-300	0.8-3.0	20-300	2.4/5000	0.01	125	70-85	F14/E15
ST4500C	200-5000	4500	54	500	250	250	40-300	0.8-3.0	20-300	2.35/5000	0.01	125	70-85	E15
ST5000C	200-5000	5000	60	500	250	250	40-300	0.8-3.0	20-300	2.4/5000	0.01	125	70-85	E15

Features

- All diffuse technics
- Ceramic disc type seal
- Middle trigger
- Bifacial cooled
- Same as two thyristor ant -abreast
- Use proper trigger current, anti & forward all could ducting

Explanation

- I_{GT}, V_{GT}, I_H are all $T_A=25^\circ\text{C}$ test data, others are all $T_A=T_{jm}$ test data
- $I^2t = I_{TSM}^2 \times tw / 2; tw = \text{Half sine wave current, when at 50Hz, } I^2t = 0.005 I_{TSM}^2 (\text{A}^2\text{S})$
- When at 60Hz, $I_{TSM}(8.3\text{ms}) = I_{TSM}(10\text{ms}) \times 1.066, T_j = T_{jm}$
- $I^2t(8.3\text{ms}) = I^2t(10\text{ms}) \times 0.943, T_j = T_{jm}$
- Gate trigger made (base point nt T1)

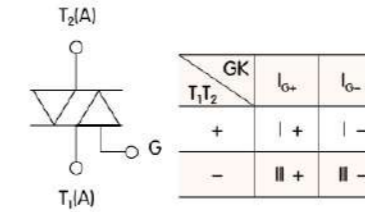

IGT, VGT, just for | +, | - || - 3 mode gate trigger
IH data for two side all could use.



Typical Applications

- AC switch
- Fast motor control

Type	$V_{CRM}V_{RRM}$	I_{TSM}	I_{TSM}	d_v/d_i	d_v/d_i	I_{DM}/I_{TSM}	I_{GT}	V_{GT}	I_H	V_{GM}/I_{TSM}	$R_{\theta(j-c)}$	T_{jm}	M^2	Outline
	V	A	kA	V/ μ S	A/ μ S	mA	mA	V	mA	V/A	$^\circ\text{C}/\text{W}$	$^\circ\text{C}$	KN	
SST200C	200-2000	200	1.7	50	50	20	20-200	0.8-2.5	20-200	2.4/300	0.120	125	3.3-5.5	E1/E2
SST300C	200-2000	300	2.5	50	50	30	20-200	0.8-2.5	20-200	2.4/500	0.065	125	5.3-10	E2
SST500C	200-2000	500	4	50	50	40	20-300	0.8-3.0	20-300	2.4/700	0.040	125	10-20	E5
SST600C	200-2000	600	4.2	50	50	40	20-300	0.8-3.0	20-300	2.4/900	0.035	125	10-20	E5
SST800C	200-2000	800	6.8	50	50	50	20-350	0.8-3.5	20-400	2.4/1200	0.035	125	15-20	E5/E8
SST1000C	200-2000	800	6.8	50	50	50	20-350	0.8-3.5	20-400	2.4/1200	0.035	125	20-30	E8

Fast Thyristor (capsule Version)

Features

- All diffuse technics
- Ceramic disc type seal
- N/middle trigger
- Good dynamic feature
- Low switch loss
- Bifacial cooled
- Fast switch feature

Explanation

- I_{GT}, V_{GT}, I_H are all $T_A=25^\circ\text{C}$ test data, others are all $T_A=T_{jm}$ test data
- $I^2t = I_{TSM}^2 \times tw / 2; tw = \text{Half sine wave current, when at 50Hz, } I^2t = 0.005 I_{TSM}^2 (\text{A}^2\text{S})$
- When at 60Hz, $I_{TSM}(8.3\text{ms}) = I_{TSM}(10\text{ms}) \times 1.066, I^2t(8.3\text{ms}) = I^2t(10\text{ms}) \times 0.943, T_j = T_{jm}$

Typical Applications

- Inverter
- Chopper
- Induction warm-up
- Current converter



Type	$V_{CRM}V_{RRM}$	I_{TSM}	t_q	d_v/d_i	d_v/d_i	I_{DM}/I_{TSM}	I_{GT}	V_{GT}	I_H	V_{GM}/I_{TSM}	$R_{\theta(j-c)}$	T_{jm}	M^2	Outline
	V	A	μ S	V/ μ S	A/ μ S	mA	mA	V	mA	V/A	$^\circ\text{C}/\text{W}$	$^\circ\text{C}$	KN	
KST200C	600-2500	200	16-35	500	200	30	40-250	0.9-2.5	20-400	2.9/600	0.065	115	5.3-10	E1/E2
KST300C	600-2500	300	16-35	500	200	30	40-250	0.9-2.5	20-400	2.8/900	0.055	115	5.3-10	E1/E2
KST400C	600-2500	400	16-35	500	300	40	40-250	0.9-2.5	20-400	2.8/1200	0.040	115	10-20	E2/E5
KST500C	600-2500	500	16-35	500	300	50	40-250	0.9-2.5	20-400	3.15/1500	0.035	115	15-20	E2/E3/E5
KST600C	600-2500	600	16-35	500	300	50	40-300	0.9-3.0	20-400	3.15/1800	0.032	115	15-20	E3/E5/E6
KST800C	600-2500	800	16-35	500	300	60	40-300	0.9-3.0	20-500	3.15/2400	0.030	115	18-25	E5/E6/E8
KST1000C	600-2500	1000	16-35	500	500	80	40-300	0.9-3.0	20-500	3.15/3000	0.024	115	19-26	E6/E8
KST1200C	600-2500	1200	16-35	500	500	100	40-300	0.9-3.0	20-500	3.15/3000	0.022	115	21-30	E8
KST1500C	600-2500	1500	16-35	500	500	120	40-300	0.9-3.5	20-500	3.15/3000	0.020	115	21-30	E8/E9
KST1800C	600-2500	1800	16-35	500	500	120	40-400	0.9-4.0	20-800	3.15/4000	0.017	115	27-34	E11/E12/13
KST2000C	600-2500	2000	40-80	500	600	160	40-450	0.9-4.5	20-1000	3.15/4000	0.016	115	30-40	E11/E12/13
KST2500C	600-2500	2500	40-80	500	600	200	40-450	0.9-4.5	20-1000	3.15/5000	0.011	115	35-47	E14/E15
KST3000C	600-2500	3000	40-80	500	600	250	40-450	0.9-4.5	20-1000	3.15/5000	0.009	115	70-85	E14/E15

Features

- All diffuse technics
- Diffuse bigger trigger
- Low switch loss
- Good dynamic feature
- Applicable frequency
- 2.5KHz-10KHz
- Ceramic disc type sea
- Bifacial cooled

Explanation

- I_{GT}, V_{GT}, I_{H1} are all $T_A=25^\circ\text{C}$ test data, others are all $T_A=T_{jm}$ test data
- $I^2t = I_{TSM}^2 \times tw / 2$; $tw = \text{Half sine wave current, when at 50Hz,}$
 $I^2t = 0.005 I_{TSM}^2 (\text{A}^2\text{S})$
- When at 60Hz, $I_{TSM}(8.3\text{ms}) = I_{TSM}(10\text{ms}) \times 1.066$,
 $I^2t(8.3\text{ms}) = I^2t(10\text{ms}) \times 0.943, T_j = T_{jm}$
- Gate trigger made (base point nt T1)

Typical Applications

- Inverter
- Welder
- Chopper
- Inductor
- Current converter



Type	V_{DGM}/V_{DGM}		IT_{VM}		I_{TSM}	d/d_1	d/d_2	I_{DGM}/I_{DGM}	I_{GT}	V_{GT}	I_H	V_{DM}/I_{DM}	$R_{th(j-c)}$	T_{jm}	M^2	Outline
	$T_{10-55^\circ\text{C}}$		100°C	10ms												
	V	A	A/kHz	μS												
GTO200C	800-1600	200	200/6	10-16	2.4	200	200	30	30-200	0.8-2.5	20-250	3.2/600	0.055	115	5.3-10	E1/E2
GTO300C	800-1600	300	300/6	10-16	3.6	200	200	40	30-250	0.8-3.0	20-400	3.2/900	0.035	115	10-20	E2
GTO400C	800-1600	400	300/10	8-10	4.8	200		40	30-250	0.8-3.0	20-400	3.2/1200	0.035	115	10-20	E2/E3
GTO500C	800-1600	500	500/6	10-16	6	200	200	50	30-250	0.8-3.0	20-400	3.2/1500	0.032	115	15-20	E3/E5
GTO600C	800-1600	600	600/6	12-18	7.2	200	250	60	30-250	0.8-3.0	20-400	3.2/1800	0.030	115	18-25	E5/E6
GTO800C	800-1600	800	800/6	12-18	9.6	200	250	80	30-250	0.8-3.0	20-400	3.2/2400	0.024	115	19-25	E6/E8
GTO1000C	800-1600	1000	1000/6	12-18	12	200	250	100	30-300	0.8-3.0	20-400	3.2/3000	0.022	115	21-30	E8
GTO1200C	800-1600	1200	800/8	8-15	14	200	250	100	30-300	0.8-3.0	20-400	3.2/3000	0.022	115	21-30	E8/E9

Welder Class Diode & Thyristor (capsule Version)

KE series feature

- Special for invert welder design
- Diffuse bigger trigger
- Low V_{TM}
- Low switch loss
- Good dynamic feature
- Could work at high switch frequency

ZE series feature

- Special for invert welder design
- Low V_{TM}
- Short recovery time
- Fast soft recovery features
- Ceramic disc type seal bifacial cooled



Type	V_{DGM}/V_{DGM}		$IF_{TAV}@T_{10}$		T_{10}	Q_{rr}	I_{SM}	I^2t	I_{RSM}	V_{DM}/I_{DM}	V_{TC}	r_f	$R_{th(j-c)}$	T_{jm}	M^2	Outline	
	100°C		10ms	25°C													150°C
	V	A	$^\circ\text{C}$	μS													μC
ZE200	200-800	200	126	3	300	5.4	100	30	2.0/900	1.38	0.40	0.055	150	5.3-10	E1/E2		
ZE300	200-800	300	122	3	500	6.7	220	40	2.0/1500	1.35	0.36	0.035	150	10-20	E1/E2		
ZE500	200-800	500	122	3	500	6.7	220	50	2.0/1500	1.35	0.35	0.035	150	15-20	E3/E5		

Type	V_{DGM}/V_{DGM}		$IF_{TAV}@T_{10}$		t_a	IT_{SM}	d/d_1	d/d_2	I_{DGM}/I_{DGM}	I_{GT}	V_{GT}	I_H	V_{DM}/I_{DM}	V_{TC}	r_f	$R_{th(j-c)}$	T_{jm}	M^2	Outline
	100°C		10ms	115°C															
	V	A	$^\circ\text{C}$	μS															
KE200	200-800	200	94	10-28	3.8	200	200	30	40-250	0.9-2.5	20-400	2.4/600	1.38	1.39	0.055	115	5.3-10	E1/E2	
KE300	200-800	300	96	10-28	5	200	200	40	40-250	0.9-2.5	20-400	2.4/900	1.32	1.36	0.035	115	10-20	E1/E2	
KE500	200-800	500	96	10-28	5	200	200	50	40-250	0.9-2.5	20-400	2.4/900	1.32	1.35	0.035	115	15-20	E3/E5	

<p>E1 A-PUK</p> <p>$\phi 26$ Power 100-200A Install force 3.3-5.5KN</p>	<p>E2 E-PUK</p> <p>$\phi 30$ Power 200-300A Install force 5.5-10KN</p>	<p>E3</p> <p>$\phi 36$ Power 300-500A Install force 10-20KN</p>
<p>E4</p> <p>$\phi 36$ Power 200-500A Install force 10-20KN</p>	<p>E5 B-PUK</p> <p>$\phi 40$ Power 300-800A Install force 15-20KN</p>	<p>E6</p> <p>$\phi 45$ Power 500-800A Install force 15-20KN</p>
<p>E7</p> <p>$\phi 50$ Power 800-1000A Install force 18-25KN</p>	<p>E8 K-PUK</p> <p>$\phi 55$ Power 1000-1500A Install force 19-26KN</p>	<p>E9</p> <p>$\phi 60$ Power 1500-2500A Install force 21-30KN</p>
<p>E10</p> <p>$\phi 65$ Power 1500-2500A Install force 27-34KN</p>	<p>E11</p> <p>$\phi 70$ Power 2000-3000A Install force 30-40KN</p>	<p>E12</p> <p>$\phi 70$ Power 2000-3000A Install force 30-40KN</p>
<p>E13 R-PUK</p> <p>$\phi 80$ Power 2500-5000A Install force 35-45KN</p>	<p>E14</p> <p>$\phi 80$ Power 2500-5000A Install force 35-45KN</p>	<p>E15</p> <p>$\phi 90$ Power 4000-5000A Install force 70-85KN</p>



Features

- All diffuse technics
- Ceramic disc type seal
- Middle trigger
- Bifacial cooled
- High current

Typical Applications

- Big power transformer
- AG & DG motor control
- AC & DC switch
- Phase control rectification
- Inverter
- Welder

Ordering Information Table

Device Code **T I 43 800 16**

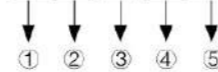

- 1** - D=Standard recovery diode DF=Fast recovery diode
DL=Avalanche rectifier diode T=Phase control thyristor
TB=Fast thyristor TC=Triac thyristor

2 - Voltage & cut time class

3 - Device outline code

4 - Current code=IF(AV) or IT(AV)

5 - Voltage code=Code x 100=V_{RRM}

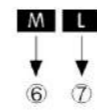

Explanation

- I_{GM}, V_{GM}, I_{SM} are all T_a=25°C test data, others are all T_a=T_{jm} test data
- I²t=I²_{SM} × t_w/2; t_w=Half sine wave current, when at 50Hz, I²t=0.005I²_{SM}(A²s)
- When at 60Hz, I_{SM}(8.3ms)=I_{SM}(10ms) × 1.066, T_j=T_{jm}
I²t(8.3ms)=I²t(10ms) × 0.943, T_j=T_{jm}

Russia Type Standard Recovery Diode(Capsule Version)

Type	V _{RRM}	I _{RRM}	IF(AV) T _c 55°C	IF(RSM) T _c 70°C	IF(SM) 10ms	V _{RM} /I _{RM} 25°C	T _j	R _{θc}	M ²	Wt	Outline
	V	mA	A	A	KA	V/A	°C	°C /W	KN	kg	
D123-200	400-3000	35	200	435	3.0	2.60/628	-40°C ~ +150°C	0.08	6	0.091	RC1
D123-250	400-3000	35	250	550	3.5	2.45/785		0.08	6	0.091	
D123-320	400-3000	35	320	650	4.2	2.25/1005		0.08	6	0.091	
D123-400	400-3000	35	400	9630	5.5	1.90/1255		0.08	6	0.091	
D123-500	400-3000	35	500	1200	7.5	1.80/1570		0.08	6	0.070	RC2
D123-530	400-3000	35	530	1512	9.0	1.30/1978		0.08	6	0.070	
D133-400	400-5000	50	400	1200	7	2.10/1256		0.036	10	0.180	RC3
D133-500	400-5000	50	500	1770	11	1.70/1570		0.038	10	0.180	
D133-630	400-5000	35	630	1970	11	1.80/1978		0.040	10	0.180	
D133-800	400-5000	40	800	2520	12	1.60/2512		0.038	10	0.180	RC4
D133-1000	400-5000	40	1000	2530	16	1.55/3140		0.036	10	0.180	
D143-630	400-5000	50	630	1695	10.5	2.10/1978		0.027	15	0.240	RC6
D143-800	400-5000	50	800	2825	16	1.55/2512		0.027	15	0.240	
D143-1000	400-5000	65	1000	3170	19	1.55/3140		0.027	15	0.240	
D143-1250	400-5000	70	1250	3285	20	1.65/3925		0.027	15	0.240	RC8
D243-800	400-5000	45	800	1755	12.5	1.95/2512		0.030	15	0.240	
D243-1000	400-5000	50	1000	2610	18	1.65/3140	0.030	15	0.240		
D153-1000	400-5000	100	1240	2420	16	2.00/3140	0.018	26	0.550	RC6	
D153-1250	400-5000	100	1480	2950	18	1.95/3925	0.018	26	0.550		
D153-1600	400-5000	100	1820	3455	22	1.80/5024	0.018	26	0.550	RC8	
D173-2000	400-5000	150	2180	4265	28	2.00/6280	0.010	45	1.200		
D173-2500	400-5000	150	2800	5485	32	1.95/7850	0.010	45	1.200		
D173-3200	400-5000	150	3200	6455	40	1.80/10048	0.010	33	1.200		
D173-4000	400-5000	150	4660	9200	50	1.65/12580	0.011	45	1.200		
D173-5000	400-5000	150	5640	11544	65	1.45/15700	0.010	45	1.200		

Russia Type Fast Recovery Diode (Capsule Version)

Type	V _{RRM}	I _{RRM}	IF(AV) T _c 55°C	IF(RSM) T _c 70°C	IF(SM) 10ms	V _{RM} /I _{RM} 25°C	T _{tr} 100°C	Q _{rr} 100°C	T _j	R _{θc}	M ²	Wt	Outline
	V	mA	A	A	KA	V/A	MS	μS	°C	°C /W	KN	kg	
DF323-200	400-3000	50	200	400	3.0	3.20/628	≤ 2	70	-40°C ~ +150°C	0.08	4.5	0.091	RC1
DF323-250	400-3000	50	250	500	4.5	1.95/785	≤ 3	70		0.08	4.5	0.067	RC2
DF333-300	400-3000	50	300	600	6.5	2.30/1250	≤ 3	100		0.04	10	0.180	RC3
DF333-400	400-3000	40	400	628	6.5	2.50/1256	≤ 3	100		0.04	10	0.180	
DF343-500	400-3000	50	500	785	10.5	3.00/1570	≤ 3	120		0.035	15	0.240	RC4
DF343-800	400-3000	40	800	1600	12.5	2.80/2500	≤ 4	130		0.035	15	0.240	
DF343-1000	400-3000	40	1000	2000	14.5	2.30/3140	≤ 4	150		0.035	15	0.240	RC6
DF353-800	400-3000	50	800	1600	9.5	3.50/2500	≤ 4	130		0.02	24	0.550	
DF353-1000	400-3000	100	1000	2000	16.0	3.20/2512	≤ 4	150		0.02	24	0.550	

Russia Type Avalanche Rectifier Diode (Capsule version)

Type	V _{RRM}	I _{RRM}	IF(AV) T _c 55°C	IF(RSM) T _c 70°C	IF(SM) 10ms	IT A ² S10 ³	V _{AV} /I _{AV} 25°C	T ₁₀	r _i	PRSM 100mks	T _j	R _{θc}	M ²	Wt	Outline
	V	mA	A	A	KA	A ² S10 ³	V/A	V	mΩ	KW	°C	°C /W	KN	kg	
DL123-320	400-1600	25	320	770	5.5	151	1.65/1000	0.90	0.830	16	-40°C ~ +150°C	0.075	6	0.070	RC2
DL133-500	400-1600	25	500	1430	12	720	1.50/1570	0.85	0.410	16		0.040	10	0.180	RC3
DL153-800	400-2000	100	800		12	720	2.50/1500			16		0.020	24	0.550	RC6
DL153-1000	400-2000	50	1250	2240	13	1620	3.00/3140	1.30	0.540	16		0.020	22	0.550	
DL153-1250	1200-3200	50	1250	1740	26	3380	2.00/4000	1.10	0.350	16		0.020	24	0.550	RC8
DL153-1600	1200-3200	50	1600	2980	26	3380	2.00/5024	1.00	0.300	16		0.020	24	0.550	
DL153-2000	1600-3200	50	2000	2650	30	4500	1.80/6280	0.90	0.185	16		0.020	24	0.550	RC8
DL173-3200	2400-3200	100	3250	5760	45	10125	2.2/10053	1.10	0.124	16		0.011	45	1.300	
DL173-4000	1600-2400	100	3860	6870	50	12500	2.2/12560	1.00	0.080	16		0.011	45	1.300	

Russia Type Phase Control Thyristor (Capsule version)

Type	V _{RRM}	I _{RRM}	IF(AV) T _c 55°C	IT(RSM) T _c 70°C	IT(SM) 10ms	V _{RM} /I _{RM} 25°C	d ₁ /d ₂	d ₁ /d ₃	I _{GT}	V _{GT}	I _H	T _j	R _{θc}	Y _a	M ²	Wt	Outline
	V	mA	A	A	KA	V/A	W/μS	A/μS	mA	mA	mA	°C	°C /W	μS	N/m	kg	
T123-200	400-1600	15	200	265	4.0	1.9/628	200	200-1600	3.5	250	200	-40°C ~ +125°C	0.08	250	6	0.07	RC1
T123-250	400-1600	20	250	750	4.5	1.75/785	200	200-1600	3.5	250	200		0.08	250	6	0.07	
T123-320	400-1600	20	330	1090	5.0	1.65/1005	200	500-1600	2.5	250	200		0.08	100-200	6	0.07	RC2
T123-500	400-800	30	500	550	6.0	1.50/1570	200	500-1600	2.5	200	250		0.07	63-125	6	0.07	
T133-400	400-1600	30	400	935	8.0	1.75/1258	200	200-1600	2.5	200	250		0.045	250	10	0.18	RC2
T133-500	100-800	50	500	1720	10	1.50/1570	320	500-1600	2.5	150	250		0.035	160	10	0.10	
T233-500	400-1800	30	500	1160	9.0	1.80/1570	200	500-1600	2.5	250	250		0.04	100-200	10	0.10	RC3
T133-600	100-800	50	600	2085	12	1.60/2512	200	500-1600	2.5	250	250		0.035	63-125	10	0.18	
T133-630	100-1200	40	630	1430	12	1.65/1978	200	500-1600	2.5	250	250		0.04	80-160	10	0.10	RC4
T143-500	400-1600	40	500	1175	11	1.80/1570	200	200-1600	3.5	300	250		0.034	250	15	0.240	
T243-500	1800-3200	40	550	1110	10	2.00/1570	200	500-1600	2.5	250	250		0.034	200-400	15	0.240	RC5
T143-600	900-1800	70	640	1250	9.0	1.95/1978	200	500-1600	2.5	250	300		0.032	160-320	15	0.240	
T143-1000	100-1200	50	800	1585	14	1.70/2512	200	500-1600	2.5	250	300		0.032	100-200	15	0.160	RC6
T143-1250	100-800	30	1045	1860	19	1.60/3140	200	500-1600	2.5	250	300		0.030	80-160	15	0.160	
T153-800	100-1000	50	800	1840	20	1.90/2512	200	200-1600	3.5	300	300		0.024	100-400	24	0.500	RC7
T153-1250	100-800	100	1250	3000	18	1.50/4000	300	500-1600	3.5	300	300		0.016	100-400	24	0.550	
T153-1600	100-800	100	1600	3500	22	1.45/5000	300	500-1600	3.5	200	300	0.016	100-400	24	0.550	RC8	
T253-500	5200-6000	150	530	1175	10	2.40/1570	100	500-1600	3.5	200	300	0.026	100-400	24	0.550		
T253-800	2000-2400	70	800	1470	17	2.10/2500	200	200-1600	3.5	350	300	0.020	100-400	24	0.550		
T253-1000	1000-1800	70	1000	2300	22	1.80/3140	200	200-1600	3.5	300	300	0.020	100-400	24	0.550		
T253-1250	400-1800	70	1250	1830	28	1.60/3925	200	200-1600	3.5	300	300	0.018	100-400	24	0.550		
T173-2000	1600-2000	200	2000	4600	49	1.65/6280	320	500-1600	3.5	300	300	0.011	100-400	24	1.200	RC8	
T173-2500	200-2400	100	2700	5750	52	1.70/7850	200	500-1600	3.5	350	300	0.010	100-400	24	1.200		
T173-3200	200-2400	200	3360	7360	60	1.50/10050	320	500-1600	3.5	300	300	0.010	100-400	24	1.200		
T173-4000	200-2400	200	4000	9200	62	1.50/12560	200	500-1600	3.5	300	300	0.010	100-400	24	1.200		

Russia Type Triac Thyristor (Capsule Version)

Type	V_{DRM}	I_{DRM}	I_{TAV}	I_{TSM}	V_{TM}/I_{TM}	d_1/d_2	d_1/d_3	V_{GT}	I_{GT}	I_H	T_j	R_{jc}	M^2	WT	Outline
	V	mA	A	KA	V/A	A/ μ S	V/ μ S	V	mA	mA					
TC123-200	200-1600	25	200	1.2	2.50/320	25	6.3-100	3.0	300	≤ 300	-40 $^{\circ}$ C ~ +125 $^{\circ}$ C	0.037	10	0.100	RC2
TC123-300	200-1600	25	300	1.6	2.20/500	25	6.3-100	3.0	300	≤ 300		0.037	10	0.100	RC2
TC133-500	200-1600	25	500	3.0	2.50/700	25	6.3-100	3.0	300	≤ 300		0.04	10	0.180	RC3
TC133-630	200-1600	25	630	3.3	2.20/800	63	6.3-100	3.0	300	≤ 300		0.37	10	0.180	RC3
TC143-800	200-1600	25	800	4.5	1.95/120	25	6.3-100	3.0	300	≤ 300	0.03	10	0.240	RC4	
TC143-1000	200-1600	25	1000	5.0	1.75/1400	25	6.3-100	3.0	300	≤ 300	0.028	10	0.240	RC4	

Russia Type Fast Thyristor (Capsule Version)

Type	V_{DRM}	I_{DRM}	I_{TAV}	I_{TSM}	I_{TSM}	V_{TM}/I_{TM}	d_1/d_2	d_1/d_3	V_{GT}	I_{GT}	I_H	T_j	R_{jc}	T_s	M^2	WT	Outline
	V	mA	A	KA	KA	V/A	A/ μ S	V/ μ S	V	mA	mA						
TB323-400	300-1400	40	400	628	6.5	2.7/1250	500	500-1000	3.5	300	≤ 200	-40 $^{\circ}$ C ~ +125 $^{\circ}$ C	0.035	12.5,16,32,40	10	0.10	RC2
TB333-500	300-1400	40	500	785	7.5	2.2/1570	500	500-1000	3.5	300	≤ 200		0.035	16,20,25,32,40	10	0.18	RC3
TB343-500	500-1000	50	500	785	9.0	2.6/1570	500	500-1000	3.5	300	≤ 200		0.028	25,2,40	15	0.16	RC4
TB143-630	500-1400	50	630	990	10.5	2.1/2000	500	500-1000	3.5	300	≤ 300		0.028	25,32,40,50	15	0.16	RC4
TB153-630	600-1400	100	630	990	1.5	2.4/2000	630	1000-1600	3.5	400	≤ 300	0.021	20,25,32,40,50	24	0.55	RC5	
TB453-800	600-1400	100	800	1250	15.0	2.3/2500	630	1000-1600	3.5	400	≤ 300	0.021	25,32,40,50,63	24	0.55	RC5	
TB143-500*	1400-2400	70	500	800	9.0	2.5/1570	500	500-1000	2.5	300	≤ 200	0.035	25,32,40,50,63	15	0.24	RC4	
TB553-800*	1400-2400	120	800	1250	17.0	2.8/2500	630	500-1000	2.5	400	≤ 400	0.021	25,32,40,50,63	24	0.55	RC6	
TB453-1000*	600-1400	100	1000	1600	16.0	2.5/3140	630	1000-1600	3.5	400	≤ 400	0.021	40,50,63	24	0.55	RC6	
TB273-2000*	1400-2400	2000	3200	40.0	1.85/6280	1000	500-1000	5.0	400	≤ 400	0.011	40,50,63	45	1.20	RC8		

Russia Type Capsule Version Outline

<p>RC1(123)</p> <p>Power: 200-300A Install force: 10-20KN</p>	<p>RC2(123B)</p> <p>Power: 300-600A Install force: 15-20KN</p>	<p>RC3(133)</p> <p>Power: 500-800A Install force: 15-20KN</p>	<p>RC4(143)</p> <p>Power: 500-1000A Install force: 18-25KN</p>
<p>RC5(143B)</p> <p>Power: 500-1000A Install force: 18-25KN</p>	<p>RC6(153)</p> <p>Power: 1000-2000A Install force: 20-30KN</p>	<p>RC7(153B)</p> <p>Power: 1000-2000A Install force: 30-40KN</p>	<p>RC8(173)</p> <p>Power: 2000-4000A Install force: 35-40KN</p>

High Power Solid-state Relay Three Phase Installation Instruction

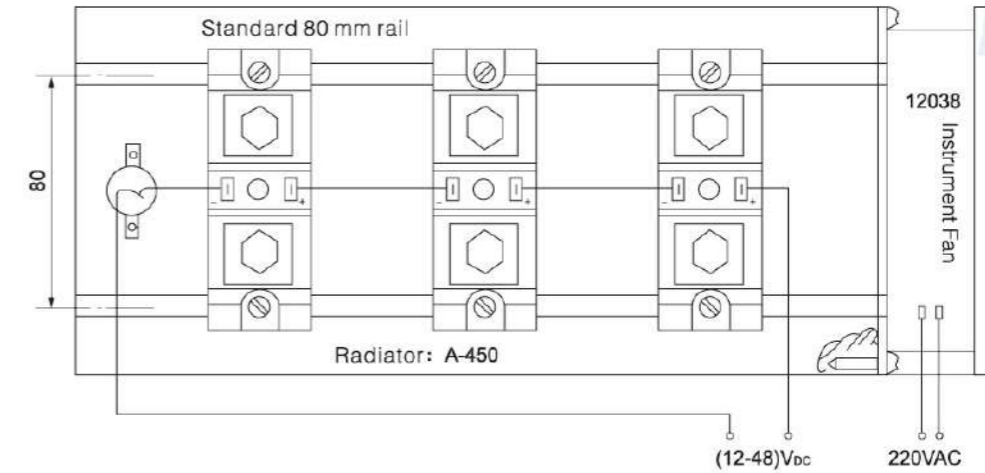

*Temperature controlled switch action as bottom limit to prevent relay from damage

Temperature controlled instrument noncontracting Voltage or current output

Installation Instruction

- The ambient temperature of applicable module should not be higher than 35 $^{\circ}$ C. If exceeding 35 $^{\circ}$ C, it should be derated. The humidity should not be higher than 85%.
- In the device, the module should be mounted in the ventilated place where the wind rate should not be less than 6m/s. Under low wind rate or self-cooling heatbarrier, it should be derated. Whatever the cooling type is, the module should not run under exceeding the shell temperature, the measurement point of shell temperature is the geometric center of long side baseboard of module.
- Table-board of radiator of mounting module should be smooth, bright and clean without any scoring. When mounting, remember to wipe off the dirt from the surface first, coat a layer of thermal conductive silicon grease (oil), such as DRZ thermal conductive grease. In this way, it is able to reduce the thermal contract resistance effectively, and reduce the shell temperature consequently, which is helpful to safety running of module.
- Fastening moment of mounting bolt is 5 \pm 1Nm, make sure that the bottom plate of module has been in close contact with table-board of radiator. Please carry out wiring correctly according to the module label and electrode marks on the shell.
- Fastening moment of connection bolt is 9 \pm 1Nm for M8, 3 \pm 0.5Nm for M5~6, make sure good contact between conductor and electrode, to reduce heat.
- In addition to the radiators recommended by this manual, users also could select radiators of other types according to needs, such as heat-pipe radiator, water-cooling radiator, air-cooling radiator of other shapes. When selecting air-cooling radiator of other shapes, the surface area required of radiator can be estimated roughly according to 15cm 2 /A. No matter which type of radiator is selected, it must be validated through tests that it is able to keep the shell temperature of module lower than the specified value in this manual.

<p>XC-M1</p> <p>Section area: 77.78cm2 circumference: 2302cm Weight: 21kg/m</p>	<p>XC-M2</p> <p>Section area: 44.45cm2 circumference: 1652cm Weight: 12kg/m</p>	<p>XC-M3</p> <p>Section area: 93.3cm2 circumference: 2540cm Weight: 25.2kg/m</p>
<p>XC-M4</p> <p>Section area: 29.3cm2 circumference: 1924cm Weight: 7.95kg/m</p>	<p>XC-M5</p> <p>Section area: 59.3cm2 circumference: 3080cm Weight: 16kg/m</p>	<p>XC-M6</p> <p>Section area: 66.7cm2 circumference: 1205cm Weight: 18.8kg/m</p>

Soild State Relay Heatsink

XC-SSR1P(10-60A)

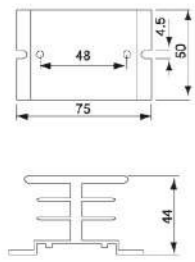

XC-SSR2P(40-120A)

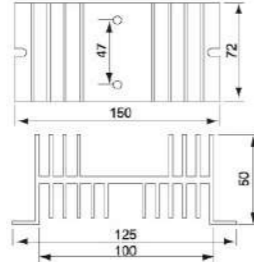

XC-SSR3P(10-100A)

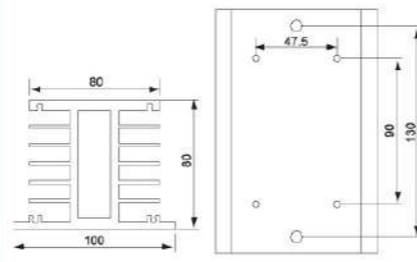

B-30, B-50

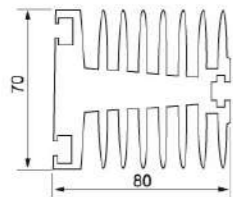

A-150, A-450

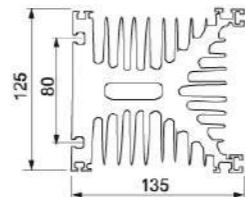

C-90, C-150

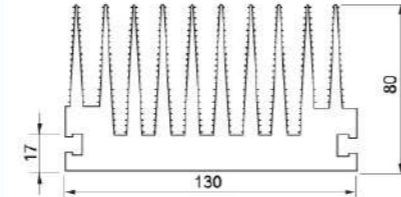

Bridge Rectifier Version Heatsink



KBPC, GBPC



QL, SQL

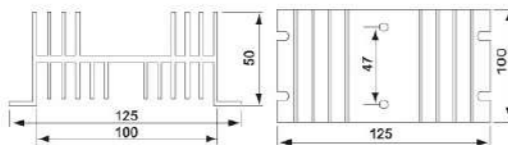

ZLXC-A3(300-600A)



XC-A1(10-85A)

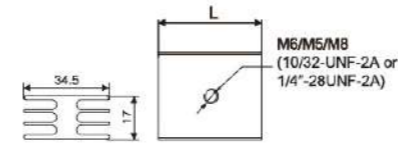

Also apply to Bridge diode 10-50A

XC-A2(100-300A)

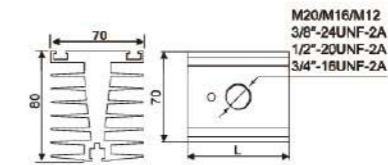

Also apply to SSR-HD series

XC-A3(300-600A)

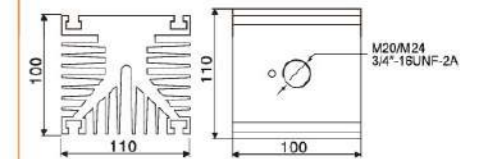

Capsule Version Heatsink

XC-B1(300-600A)

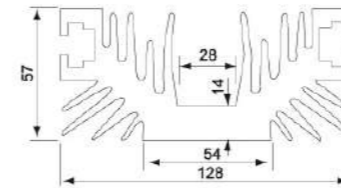

XC-B2(500-800A)

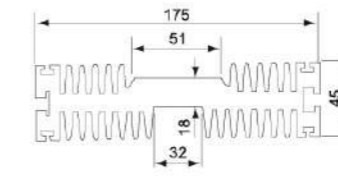

XC-B3(600-1000A)

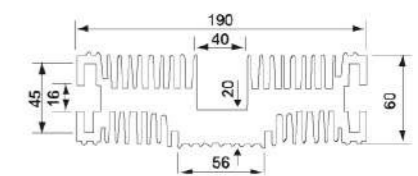

Section area	circumference	Weight	Section area	circumference	Weight	Section area	circumference	Weight
31cm ²	1190cm	8.4kg/m	35.9cm ²	1513cm	9.7kg/m	62.13cm ²	2170cm	14.4kg/m

XC-B4(1500-2000A)

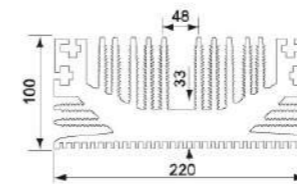

XC-B5(2000-3000A)

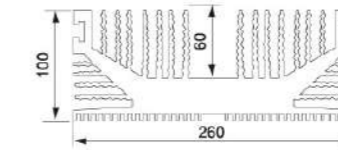

XC-B6(200-500A)

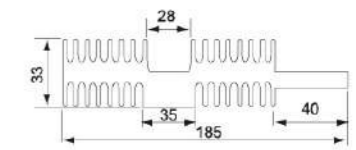

Section area	circumference	Weight	Section area	circumference	Weight	Section area	circumference	Weight
104.5cm ²	2233cm	28.2kg/m	125.6cm ²	3400cm	43.2kg/m	29.53cm ²	1090cm	8kg/m

XC-B4(1500-2000A)

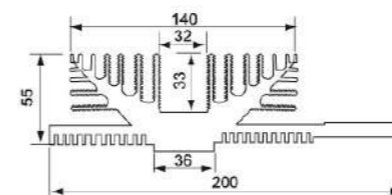

XC-B5(2000-3000A)

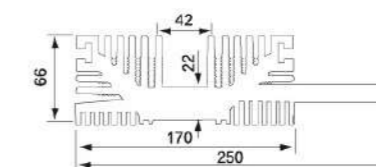

XC-B6(200-500A)

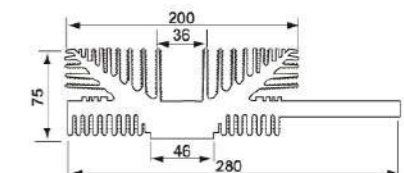

Section area	circumference	Weight	Section area	circumference	Weight	Section area	circumference	Weight
104.5cm ²	2233cm	28.2kg/m	125.6cm ²	3400cm	43.2kg/m	29.53cm ²	1090cm	8kg/m

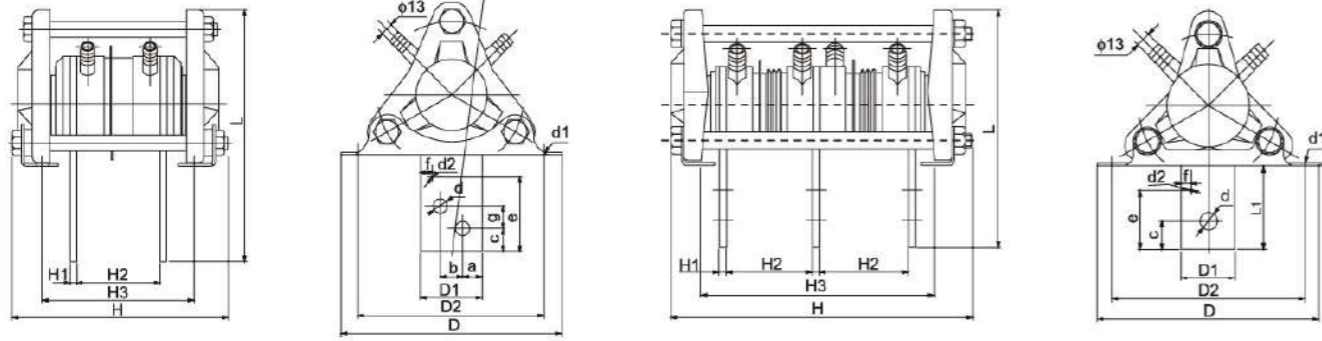

SS11, SS12, SS13, SS14

Type Single device heatsink

SS11BL, SS12BL, SS13BL, SS14BL

Double device heatsink

Type	Dimension			Terminal dimension					Install dimension												
	L	D	H	L1	H1	D1	D2	H2	H3	d	d1	d2	b	c	e	f	g	i	j	k	
SS11	140	135	145.5	53	4	30	112	64	105	2-Φ9	9×14	M3	/	20	35	6	/	45			
SS12	190	160	152	78	5	40	140	64	105	2-Φ13	11×14	M3	/	20	60	8	/	45			
SS11BL	140	135	215	53	4	30	112	64	147	3-Φ9	9×14	M3	/	20	35	6	/				
SS12BL	190	160	220	78	5	40	140	64	172	3-Φ13	11×14	M3	/	20	65	8	/				
SS13	190	160	152	78	6	50	140	64	105	4-Φ13	11×13	M3	20	15	60	8	20	45			
SS14	220	195	188	85	6	55	165	74	130	4-Φ13	11×13	M3	20	20	65	10	20	45			
SS13BL	190	160	220	78	6	50	140	64	172	4-Φ13	11×13	M3	20	15	60	8	20				
SS14BL	220	195	268	85	6	55	165	74	210	4-Φ13	11×13	M3	20	20	65	10	20				

SS15 Single device heatsink

SS15 Single device heatsink

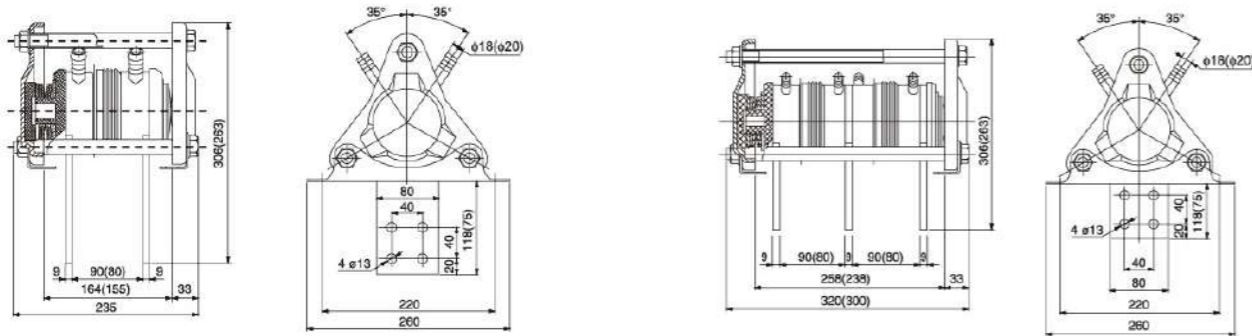

DSS3, DSS5, DSS6, DSS8 counter-abreast heatsink

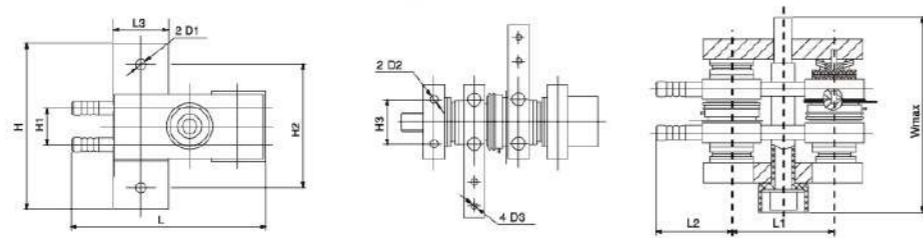

Type	Dimension				Install dimension							
	L	L1	L2	L3	H	H1	H2	H3	D1	D2	D3	Wmax
DSS3	140	70	50	40	118	25	88	25	Φ8.2	M5×7	M3×6	135
DSS5	170	88	57	50	130	30	100	30	Φ11	M6×15	M3×6	155
DSS6	148	93	59.5	55	151	35	121	35	Φ11	M6×15	M3×6	155
DSS8	202	100	62	60	190	50	160	50	Φ11	M6×15	M3×6	160

SF14, SF15, SF16, SF17 Air-cool heatsink

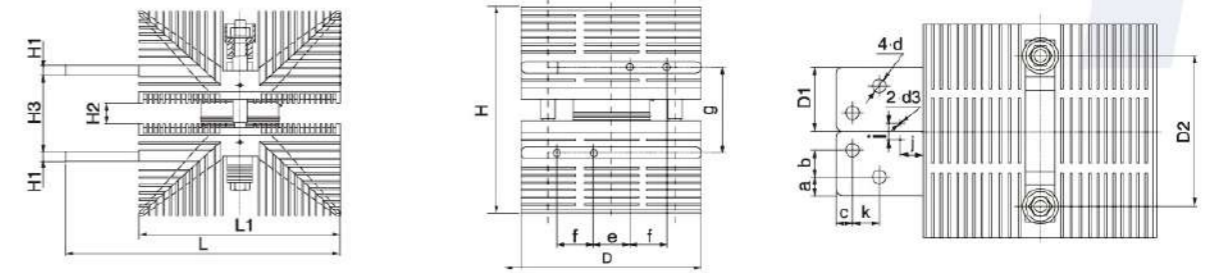

Type	Dimension			Terminal dimension			Install dimension													
	L	D	H	L1	H1	D1	D2	H2	H3	d	d1	a	b	c	e	f	g	i	j	k
SF14	250	140	145	80	50	10	105	15	45	Φ11	M6	12.5	25	12.5	40	35	55	8	20	25
SF15	280	140	165	80	60	12	110	15	50	Φ11	M6	17.5	25	15	40	35	62	8	20	25
SF16	280	180	200	80	60	12	130	15	66	Φ13	M6	17.5	25	15	30	40	78	8	20	25
SF17	300	200	215	80	60	12	130	15	73	Φ13	M6	17.5	25	15	40	40	85	8	20	25
SF17A	300	200	224	80	60	12			82	Φ13	M6	17.5	25	15	40	40	94	8	20	25

SF12BL Double Devices Air-cool Heatsink

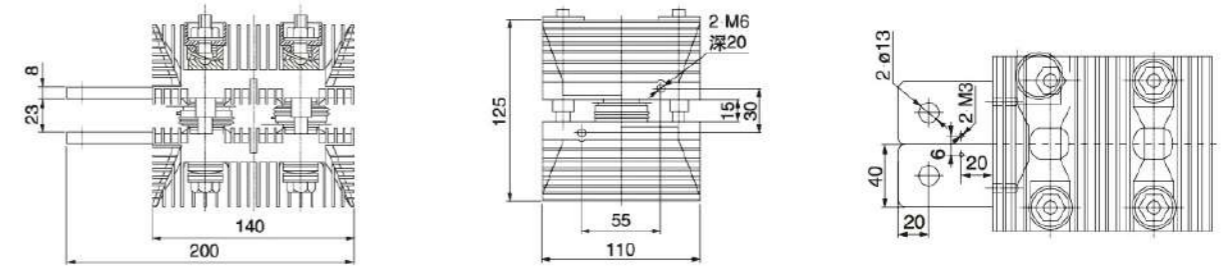

SF15BL Double Devices Air-cool Heatsink

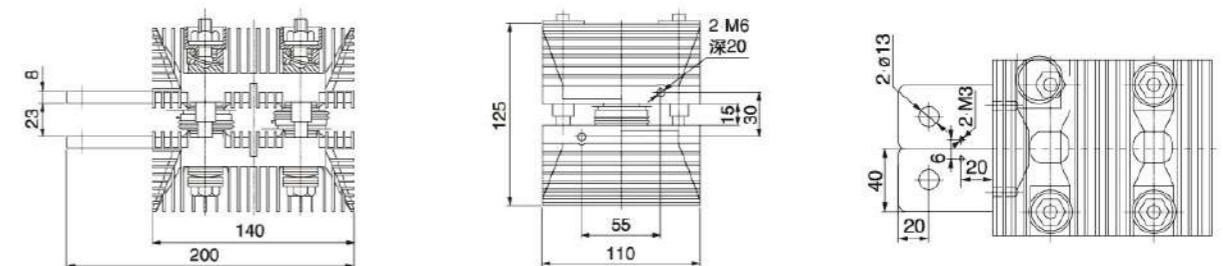

SF15CL Double Devices Air-cool Heatsink

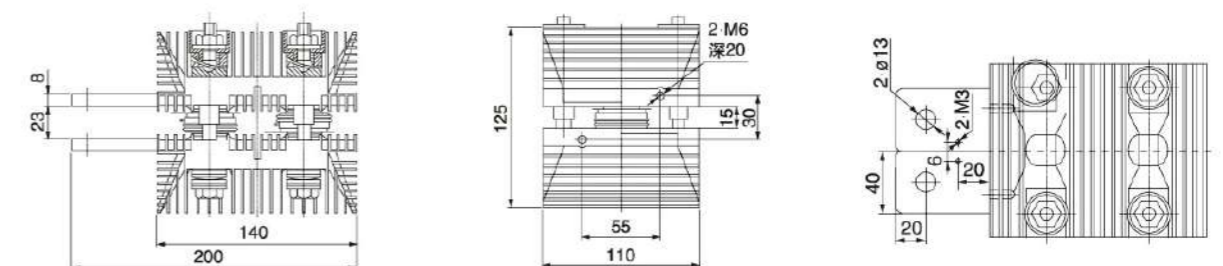

Welding Rectifier Assembly

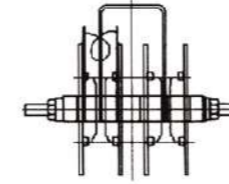

Carbon dioxide protection welding machine rectifier bridge NBC series				357x130x160
	UQDQ200A	150-500	200	
SF500	UQDQ300A	150-500	300	
SL1000	UQDQ400A	150-500	400	
SL2000	UQDQ500A	150-500	500	

Type	VRRM(A)	VRRM(A)	IRR(mA)	YTM(V)	H(V)	Temperature(°C)	Fix Power(N/M)	Speed(m/s)
TPE100A+D	100	≥ 600	≤ 3	≤ 1.2	150	≤ 55	≥ 12.5	3.0
TPE150A+D	150	≥ 600	≤ 4	≤ 1.2	150	≤ 60	≥ 12.5	3.0
TPE200A+D	200	≥ 600	≤ 5	≤ 1.3	150	≤ 60	≥ 12.5	3.0
TPE250A+D	250	≥ 600	≤ 5	≤ 1.3	150	≤ 65	≥ 12.5	3.0
TPE300A+D	300	≥ 600	≤ 6	≤ 1.3	150	≤ 80	≥ 12.5	3.0
TPE400A+D	400	≥ 600	≤ 6	≤ 1.4	150	≤ 85	≥ 12.5	3.0
TPE500A+D	500	≥ 600	≤ 7	≤ 1.4	150	≤ 90	≥ 12.5	3.0

Main Technail Specifications

Type	VRRM(A)	VRRM(A)	IRR(mA)	YTM(V)	H(V)	Temperature(°C)	Fix Power(N/M)	Speed(m/s)
TPE100A+S	100	≥ 600	≤ 3.5	≤ 1.30	150	≤ 55	≥ 12.5	3.0
TPE150A+S	150	≥ 600	≤ 4.0	≤ 1.30	150	≤ 60	≥ 12.5	3.0
TPE200A+S	200	≥ 600	≤ 5.5	≤ 1.35	150	≤ 60	≥ 12.5	3.0
TPE250A+S	250	≥ 600	≤ 6.0	≤ 1.35	150	≤ 65	≥ 12.5	3.0
TPE300A+S	300	≥ 600	≤ 6.5	≤ 1.35	150	≤ 80	≥ 12.5	3.0
TPE400A+S	400	≥ 600	≤ 8.0	≤ 1.40	150	≤ 85	≥ 12.5	3.0
TPE500A+S	500	≥ 600	≤ 10.0	≤ 1.40	150	≤ 85	≥ 12.5	3.0
TPE600A+S	600	≥ 600	≤ 10.0	≤ 1.45	150	≤ 90	≥ 12.5	3.0

Single Phase Bridge Rectifier Outline

DQ-1

DQ-2

DQ-3

DQ-4

DQ-5



Stud Version Base



Metal-glass cap



Ceramic cap (IR type)

Ceramic cap(Russia type)



Capsule cover (standard type and Russia type)

If big QTY can be defined, all part all could be sell directly, dimension plus check finish product's outline.

Three-phase Bridge Rectifier Outline

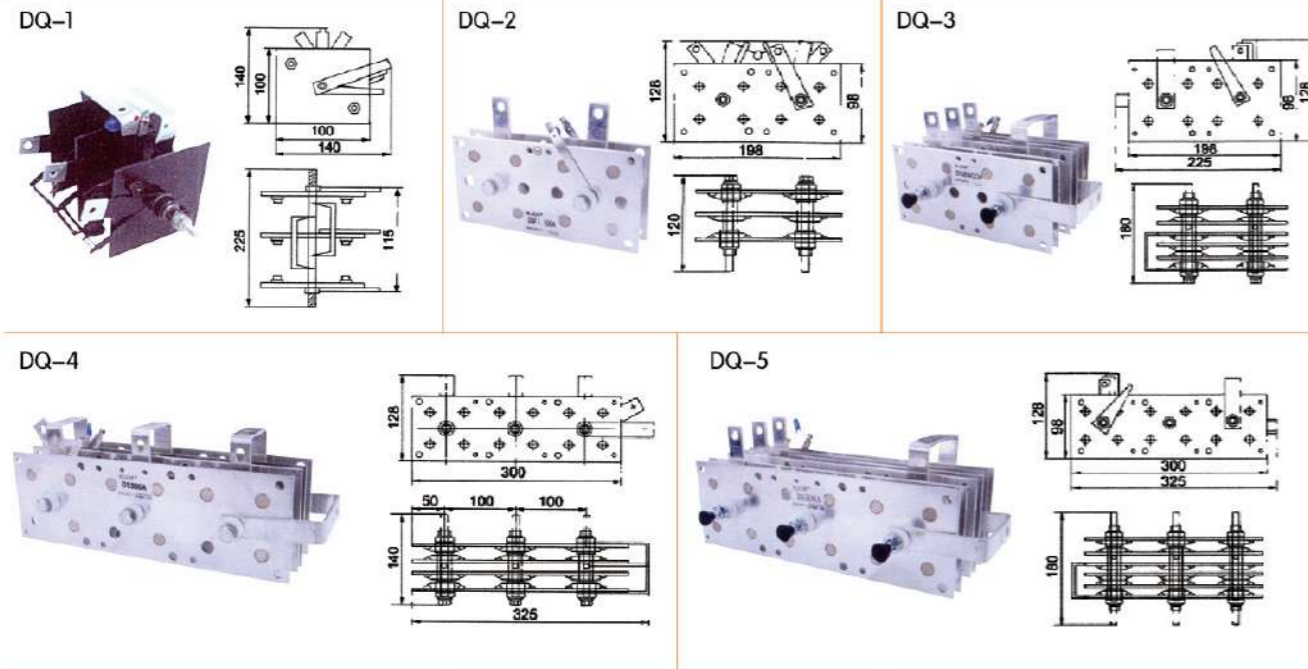

Other off-standard type products

(If big QTY can be defined, off-standard products can be custom-made!)

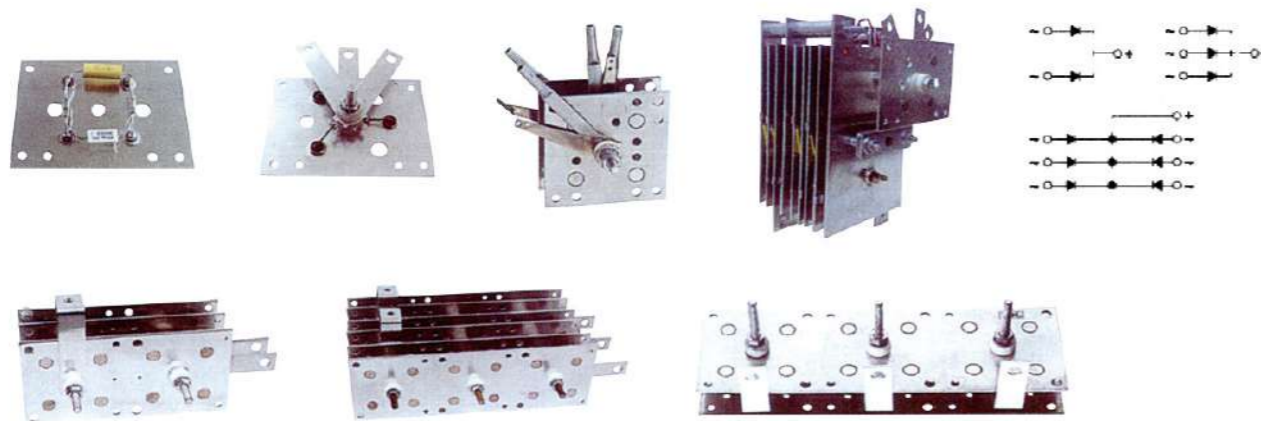

Three-phase Full Control Thyristor Bridge



Features

- Diffused junction
- Low leakage
- Low cost
- High surge current capability

Mechanical Data

- Case & terminal:red copper
- Terminal:easy for soldering
- Polarity:standard cathode to case red color
Reverse Anode to case black color

Outline Dimension List

Bosch type		DIM	Standard type	
Min	Max		Min	Max
12.90	13.06	A	12.90	13.06
7.70	8.10	B	8.60	9.00
1.25	1.31	C	1.80	2.20
29.10	31.10	D	54.00	56.00
11.10	11.50	E	16.10	16.50

Ordering Information Table

Device Code: **ZQ - 35 06 R A**

① ② ③ ④ ⑤

- 1** - ZQ=ECC standard recovery press-fit diode
ZA=ECC Avalanche press-fit diode
ZS=ECC Schottky press-fit diode
- 2** - Average rectified output current
- 3** - Voltage code=Code x 100=VRRM
- 4** - Polarity: None=Standard, Cathode to case, red color
R=Reverse, Anode to case, black or green color
- 5** - Outline number: None=Bosch type
A=Old standard, soft wire type
B, C, D, E, F, G, H are all un-standard case

*Different size all could custom-design.

Maximum Ratings and Electrical Characteristics @TA=25°C unless otherwise specified

Single phase, half wave, 60Hz, resistive or inductive load.For capacitive load, derate current by 20%.

Characteristic	Symbol	ZQ10A	ZQ15A	ZQ25A	ZQ35A	ZQ50A	Unit
Peak repetitive reverse voltage	VRRM	50-600					V
Working peak reverse voltage	VDC	50-600					V
DC blocking voltage		50-600					V
RMS reverse voltage	VR(RMS)	0.7 x VRRM					V
Average rectified output current @TA=150°C	IFI(AV)	10	15	25	35	500	A
Non-repetitive peak forward surge current 8.3ms single half sine-wave superimposed on rated load (JEDEC method)	FSM	200	300	400	400	1.1	A
Forward voltage @IF=80A	VFM	1.0	1.0	1.05	1.08		V
Peak reverse current @TA=25°C	IRM	5.0	5.0	5.0	5.0	5.0	Aμ
At rated DC blocking voltage @TA=100°C		250	250	250	250	250	Aμ
Typical junction capacitance (Note 1)	Cj	300					pF
Typical thermal resistance junction to case (Note 2)	RθJC	1.0					K/W
Operating and storage temperature range	TJ,TSTG	-65 to +175					°C

If need VRRM > 600V or un-standard type, pls contact ECC.

*also could make Avalanche diode, Schottky diode.

Other off-standard size

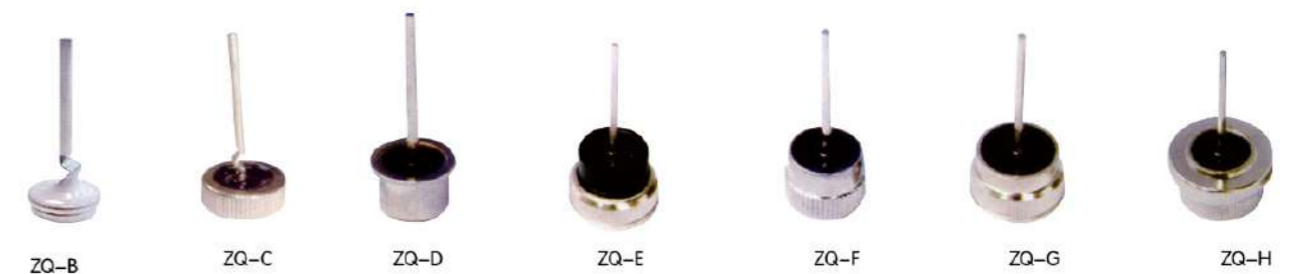

General Relay



General Relay



General Relay



High Power Relay



High Power Relay/Time relay



Time relay



Time relay/Relay socket



Relay socket

