



RAYSTAR

RAYSTAR Optronics, Inc.  
曜凌光電股份有限公司



# 曜凌光電股份有限公司 Raystar Optronics, Inc.

42881台中市大雅區科雅路25號5樓  
5F, No. 25, Keya Road, Daya Dist., Taichung City 42881, Taiwan  
T : +886-4-2565-0761 | F : +886-4-2565-0760  
sales@raystar-optronics.com | www.raystar-optronics.com

## RFJ320D-ALW-DNS

### SPECIFICATION

CUSTOMER:

<b>APPROVED BY</b>	
<b>PCB VERSION</b>	
<b>DATE</b>	

FOR CUSTOMER USE ONLY

<b>SALES BY</b>	<b>APPROVED BY</b>	<b>CHECKED BY</b>	<b>PREPARED BY</b>

Release DATE:

TFT Display Inspection Specification: <https://www.raystar-optronics.com/download/products.htm>  
Precaution in use of TFT module: <https://www.raystar-optronics.com/download/declaration.htm>

## Revision History

VERSION	DATE	REVISED PAGE NO.	Note
0	2021/01/27		First issue

RAYSTAR OPTRONICS

# Contents

1. Module Classification Information
2. Summary
3. General Specifications
4. Interface
5. Contour Drawing
6. Block Diagram
7. Absolute Maximum Ratings
8. Electrical Characteristics
9. Optical Characteristics
10. Reliability
11. Other

# 1.Module Classification Information

<b>R</b>	<b>F</b>	<b>J</b>	<b>32</b>	<b>0D</b>	<b>-</b>	<b>A</b>	<b>L</b>	<b>W</b>	<b>-</b>	<b>D</b>	<b>N</b>	<b>S</b>
1	2	3	4	5	-	6	7	8	-	9	10	11

Item	Description		
1	R : Raystar Optronics Inc.		
2	Display Type : F→TFT Type, J→ Custom TFT		
3	Solution: A: 128x160    B:320x234    C:320x240    D:480x234    E:480x272 F:800x480    G:640x480    H:1024x600    I:320x480    J:240x320 K:1280x800    L:240x400    M:1024x768    N:128x128    O:480x800 P:640x320    Q:800x600    S:480x128    T:800x320		
4	Display Size : 3.2" TFT		
5	Version Code.		
6	Model Type: A : TFT LCD E : TFT+FR+CONTROL BOARD J : TFT+FR+A/D BOARD N : TFT+FR+A/D BOARD+CONTROL BOARD S : TFT+FR+POWER BOARD (DC TO DC) 1 : TFT+CONTROL BOARD 6 : TFT+FR H : TFT+D/V BOARD I : TFT+FR+D/V BOARD B : TFT+POWER BD		
7	Polarizer Type, Temperature range, View direction I→Transmissive, W. T, 6:00 ;    C→Transmissive, N. T, 6:00 L→Transmissive, W.T,12:00 ;    F→Transmissive, N.T,12:00 Y→Transmissive,W.T, IPS TFT ; A→Transmissive, N.T, IPS TFT Z→Transmissive, W.T, O-TFT R→Transmissive, Super W.T, O-TFT N→Transmissive, Super W.T, 6:00; Q→Transmissive, Super W.T, 12:00 V→Transmissive, Super W.T, VA TFT		
8	Backlight	W : LED, White	H : LED, High Light White
		F : CCFL, White	
9	Driver Method	D: Digital    A: Analog    L : LVDS    M:MIPI	
10	Interface	N : without control board    A : 8Bit    B : 16Bit	
		S:SPI Interface    R: RS232    U:USB    I: I2C	
11	TS	N : Without TS    S : resistive touch panel	
		C : capacitive touch panel capacitive touch panel (G-F-F)	
		G : capacitive touch panel(G-G)	

---

## 2.Summary

TFT 3.2" is a TN transmissive type color active matrix TFT liquid crystal display that uses amorphous silicon TFT as switching devices. This module is composed of a TFT\_LCD module, it is usually designed for industrial application and this module follows RoHS,

RAYSTAR OPTRONICS

---

### 3. General Specifications

- Size: 3.2 inch
- Dot Matrix: 240x RGBx 320(TFT) dots
- Module dimension: 55.04 (W) x 77.6 (H) x 3.65(D) mm
- Active area: 48.6 x 64.8 mm
- Pixel pitch: 0.2025 x 0.2025 mm
- LCD type: TFT, Normally White, Transmissive
- View Direction: 6 o'clock
- Gray Scale Inversion Direction: 12 o'clock
- Aspect Ratio: Portrait
- Driver IC: ILI9341 or Equivalent
- Interface: 80 MCU 8bit /9bit/16bit/18bit/SPI(3 Wire/4 Wire)
- Backlight Type: LED, Normally White
- With /Without TP: With RTP
- Surface: Glare

\*Color tone slight changed by temperature and driving voltage.

## 4.Interface

### LCM PIN Definition

NO	Symbol	Function	I/O
1	YU	Y up for touch panel	—
2	XL	X left for touch panel	—
3	YD	Y down for touch panel	—
4	XR	X right for touch panel	—
5	VCI	Power supply(TYP: 2.8V).	P
6	IOVCC	Power supply(TYP:1.8V/2.8V).	P
7	R5	18-bit parallel bi-directional data bus for MCU system and RGB interface mode Fix to VSS level when not in use	I/O
8	R4		
9	R3		
10	R2		
11	R1		
12	R0		
13	G5		
14	G4		
15	G3		
16	G2		
17	G1		
18	G0		
19	B5		
20	B4		
21	B3		
22	B2		
23	B1		
24	B0		
25	SDA	Serial data input/output	I/O
26	DOTCLK	Data enable signal in RGB interface.	I
27	DE	A data ENABLE signal in RGB I/F mode	I
28	HSYNC	Horizontal synchronizing signal in RGB interface	I
29	VSYNC	Vertical synchronizing signal in RGB interface	I



30	NRD	Read enable pin I80 parallel bus system interface	I																																												
31	NWR_DNC	NWR Write enable pin I80 parallel bus system interface DNC Command/parameter or display data selection pin in serial bus system interface	I																																												
32	DNC_SCL	DNC Command/parameter or display data selection pin in parallel interface SCL Serial data clock in serial bus system Interface	I																																												
33	NCS	Chip select signal	I																																												
34	NRESET	System Reset	I																																												
35	IM0	System interface select: <table border="1" data-bbox="492 636 1044 978"> <thead> <tr> <th rowspan="2">IM2</th> <th rowspan="2">IM1</th> <th rowspan="2">IM0</th> <th rowspan="2">MCU-Interface Mode</th> <th colspan="2">DB Pin in use</th> </tr> <tr> <th>Register/Content</th> <th>GRAM</th> </tr> </thead> <tbody> <tr> <td>0</td> <td>0</td> <td>0</td> <td>80 MCU 8-bit bus interface I</td> <td>D[7:0]</td> <td>D[7:0]</td> </tr> <tr> <td>0</td> <td>0</td> <td>1</td> <td>80 MCU 16-bit bus interface I</td> <td>D[7:0]</td> <td>D[15:0]</td> </tr> <tr> <td>0</td> <td>1</td> <td>0</td> <td>80 MCU 9-bit bus interface I</td> <td>D[7:0]</td> <td>D[8:0]</td> </tr> <tr> <td>0</td> <td>1</td> <td>1</td> <td>80 MCU 18-bit bus interface I</td> <td>D[7:0]</td> <td>D[17:0]</td> </tr> <tr> <td>1</td> <td>0</td> <td>1</td> <td>3-wire 9-bit data serial interface I</td> <td colspan="2">SDA: In/OUT</td> </tr> <tr> <td>1</td> <td>1</td> <td>0</td> <td>4-wire 8-bit data serial interface I</td> <td colspan="2">SDA: In/OUT</td> </tr> </tbody> </table>	IM2	IM1	IM0	MCU-Interface Mode	DB Pin in use		Register/Content	GRAM	0	0	0	80 MCU 8-bit bus interface I	D[7:0]	D[7:0]	0	0	1	80 MCU 16-bit bus interface I	D[7:0]	D[15:0]	0	1	0	80 MCU 9-bit bus interface I	D[7:0]	D[8:0]	0	1	1	80 MCU 18-bit bus interface I	D[7:0]	D[17:0]	1	0	1	3-wire 9-bit data serial interface I	SDA: In/OUT		1	1	0	4-wire 8-bit data serial interface I	SDA: In/OUT		I
IM2	IM1	IM0					MCU-Interface Mode	DB Pin in use																																							
			Register/Content	GRAM																																											
0	0	0	80 MCU 8-bit bus interface I	D[7:0]	D[7:0]																																										
0	0	1	80 MCU 16-bit bus interface I	D[7:0]	D[15:0]																																										
0	1	0	80 MCU 9-bit bus interface I	D[7:0]	D[8:0]																																										
0	1	1	80 MCU 18-bit bus interface I	D[7:0]	D[17:0]																																										
1	0	1	3-wire 9-bit data serial interface I	SDA: In/OUT																																											
1	1	0	4-wire 8-bit data serial interface I	SDA: In/OUT																																											
36	IM1																																														
37	IM2																																														
38	GND	Ground	P																																												
39	VLED+	Anode of LED backlight.	P																																												
40	VLED-	Cathode of LED backlight.	P																																												

# 5. Contour Drawing

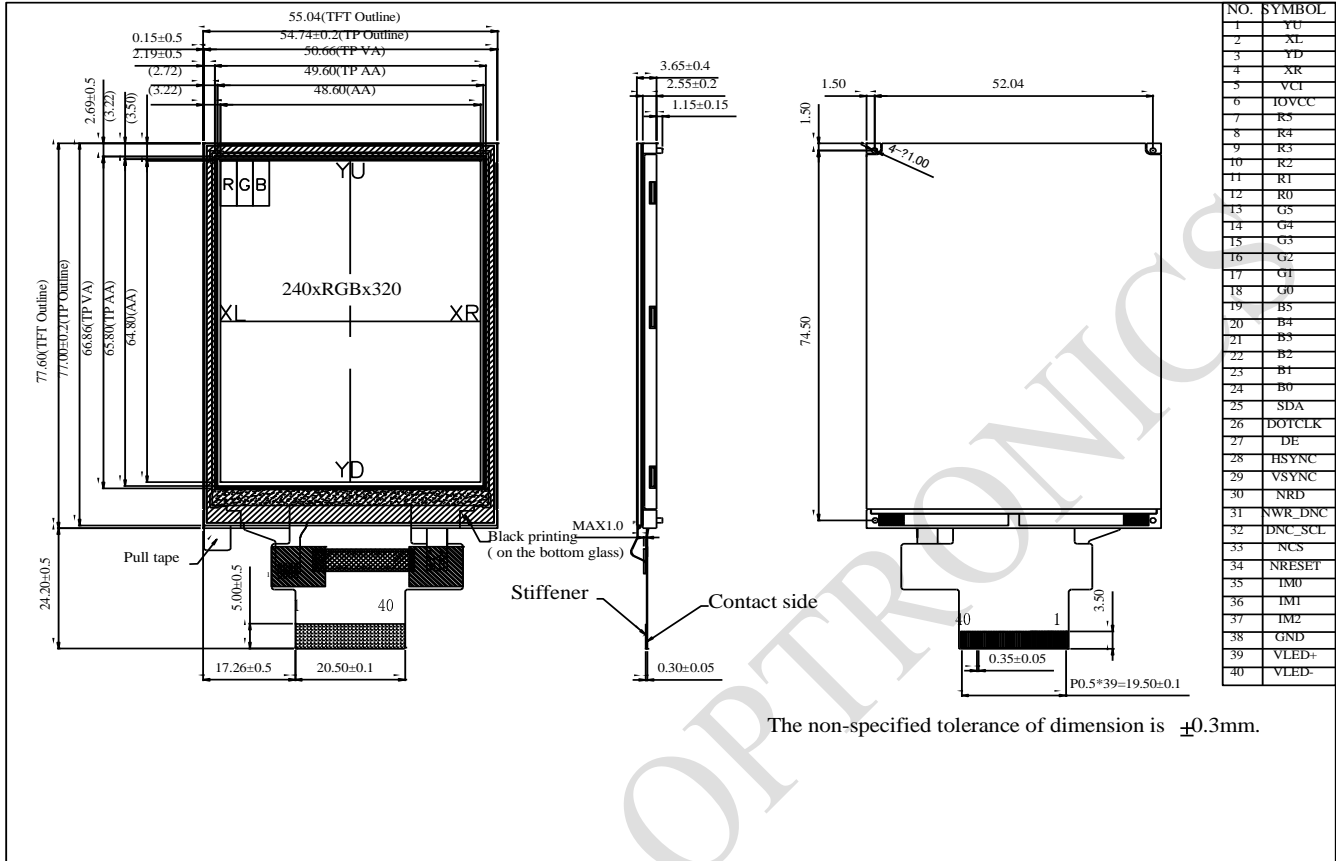

## 6. Block Diagram

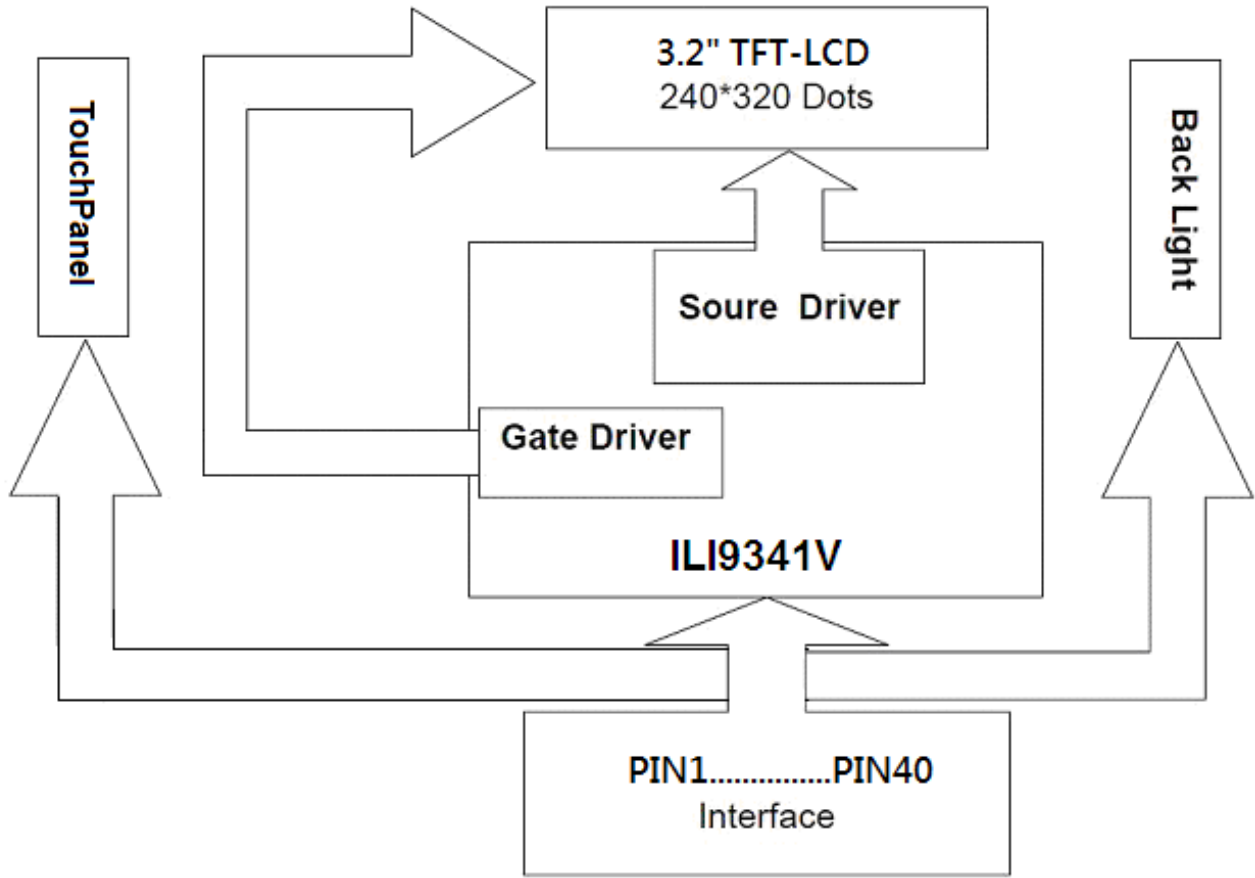

RAYSTAR

## 7. Absolute Maximum Ratings

Item	Symbol	Min	Typ	Max	Unit
Operating Temperature	TOP	-20	—	+70	□
Storage Temperature	TST	-30	—	+80	□

Note: Device is subject to be damaged permanently if stresses beyond those absolute maximum ratings listed above

- Temp. □60□, 90% RH MAX. Temp. >60□, Absolute humidity shall be less than 90% RH at 60□

RAYSTAR OPTRONICS

## 8. Electrical Characteristics

### 8.1. Operating conditions:

Item	Symbol	Condition	Min	Type	Max	Unit
Power supply voltage	V <sub>CI</sub>		2.5	2.8	3.3	V
Power supply voltage	IOVCC		1.65	2.8	3.3	V
Input high voltage	V <sub>ih</sub>		0.7IOVCC	-	IOVCC	V
Input low voltage	V <sub>il</sub>		GND	-	0.3IOVCC	V
Output high voltage	V <sub>oh</sub>	IOL=-1.0mA	0.8 IOVCC	-	IOVCC	V
Output low voltage	V <sub>ol</sub>	IOL =1.0mA	GND	-	0.2 IOVCC	V
Current consumption	I <sub>vci</sub>	-	-	5.5	8.25	mA

This value is test for VDD=3.3V , Ta=25 °C only

### 8.2. LED driving conditions

Parameter	Symbol	Min	Typ	Max	Unit	Remark
LED current	—	—	120	—	mA	—
LED voltage	V <sub>LED+</sub>	2.7	3.1	3.4	V	Note 1
LED Life Time	—	—	50000	—	Hr	Note 2,3

Note 1 : There are 1 Groups LED

Note 2 : Ta = 25°C

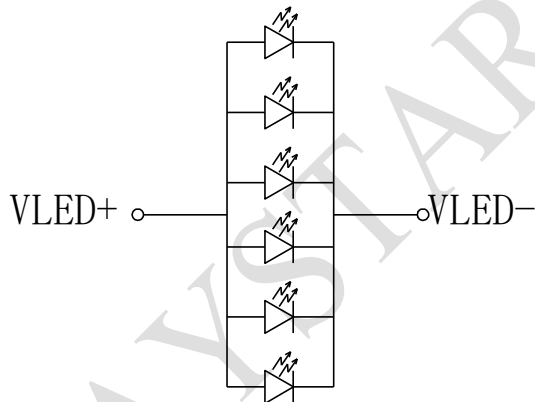

### CIRCUIT DIAGRAM

Note 3 : Brightness to be decreased to 50% of the initial value

## 9. Optical Characteristics

Item	Symbol	Condition.	Min	Typ.	Max.	Unit	Remark	
Response time	Tr	$\theta=0^\circ$ 、 $\Phi=0^\circ$	-	4	8	.ms	Note 3	
	Tf		-	12	24	.ms		
Contrast ratio	CR	At optimized viewing angle	400	500	-	-	Note 4	
Color Chromaticity	White	$\theta=0^\circ$ 、 $\Phi=0^\circ$	Wx	0.26	0.31	0.36		Note 2,6,7
			Wy	0.28	0.33	0.38		
Viewing angle (Gray Scale Inversion Direction)	Hor.	$CR \geq 10$	$\Theta_R$	35	45	-	Deg.	Note 1
			$\Theta_L$	35	45	-		
	Ver.		$\Phi_T$	35	45	-		
			$\Phi_B$	10	20	-		
Brightness	-	-	250	350	-	cd/m <sup>2</sup>	Center of display	
Uniformity	(U)	-	75	-	-	%	Note 5	

Ta=25±2°C

Note 1: Definition of viewing angle range

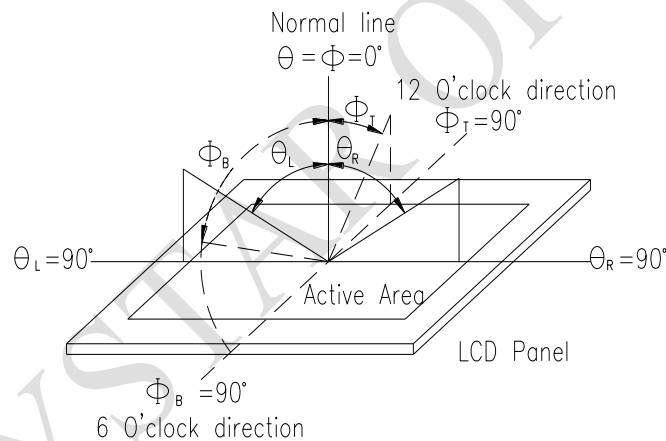

Fig 9.1. Definition of viewing angle

Note 2: Test equipment setup:

After stabilizing and leaving the panel alone at a driven temperature for 10 minutes, the measurement should be executed. Measurement should be executed in a stable, windless, and dark room. Optical specifications are measured by Topcon BM-7 or BM-5 luminance meter 1.0° field of view at a distance of 50cm and normal direction.

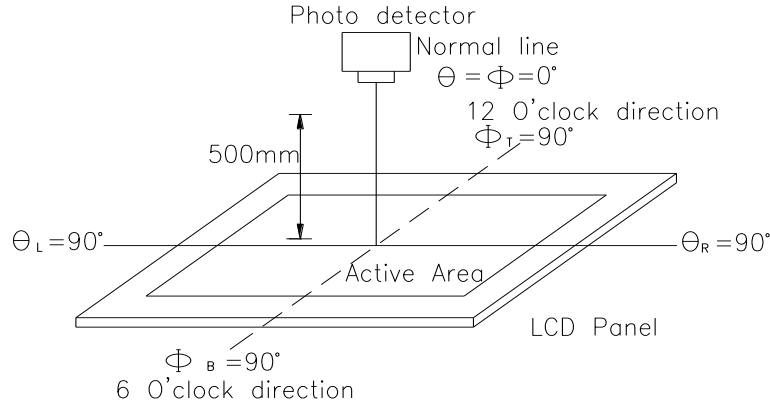
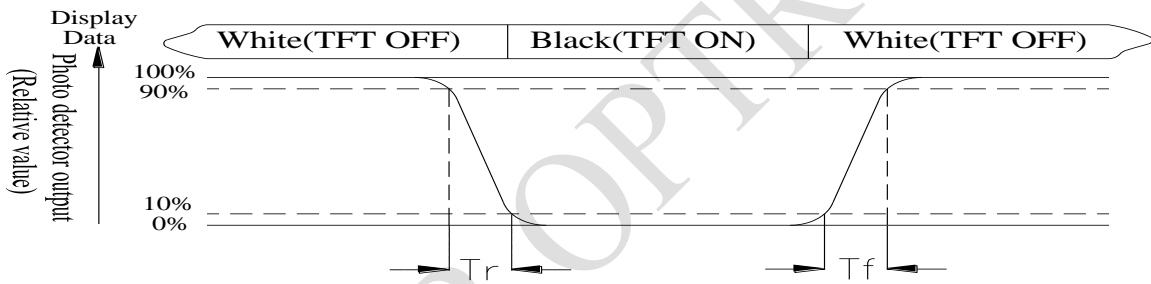

Fig 9.2. Optical measurement system setup

Note 3: Definition of Response time:

The response time is defined as the LCD optical switching time interval between “White” state and “Black” state. Rise time,  $T_r$ , is the time between photo detector output intensity changed from 90% to 10%. And fall time,  $T_f$ , is the time between photo detector output intensity changed from 10% to 90%



Note 4: Definition of contrast ratio:

The contrast ratio is defined as the following expression.

$$\text{Contrast ratio (CR)} = \frac{\text{Luminance measured when LCD on the "White" state}}{\text{Luminance measured when LCD on the "Black" state}}$$

**Note 5: Definition of Luminance Uniformity**

Active area is divided into 9 measuring areas (reference the picture in below). Every measuring point is placed at the center of each measuring area.

Luminance Uniformity (U) =  $L_{min}/L_{max} \times 100\%$

L = Active area length

W = Active area width

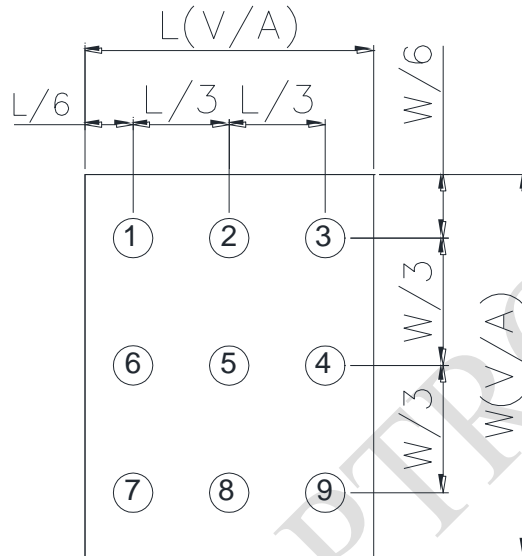

Fig 9.3. Definition of uniformity

**Note 6: Definition of color chromaticity (CIE 1931)**

Color coordinates measured at the center point of LCD

Note 7: Measured at the center area of the panel when all the input terminals of LCD panel are electrically opened.



## 10. Reliability

Content of Reliability Test (Wide temperature, -20°C~70°C)

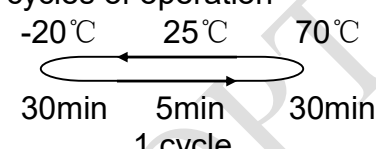
Environmental Test			
Test Item	Content of Test	Test Condition	Note
High Temperature storage	Endurance test applying the high storage temperature for a long time.	80°C 96hrs	2
Low Temperature storage	Endurance test applying the low storage temperature for a long time.	-30°C 96hrs	1,2
High Temperature Operation	Endurance test applying the electric stress (Voltage & Current) and the thermal stress to the element for a long time.	70°C 96hrs	—
Low Temperature Operation	Endurance test applying the electric stress under low temperature for a long time.	-20°C 96hrs	1
High Temperature/ Humidity Operation	The module should be allowed to stand at 40°C, 90%RH max	40°C, 90%RH 96hrs	1,2
Thermal shock resistance	The sample should be allowed stand the following 10 cycles of operation <div style="text-align: center;">  <p>-20°C    25°C    70°C</p> <p>30min    5min    30min</p> <p>1 cycle</p> </div>	-20°C/70°C 10 cycles	—
Vibration test	Endurance test applying the vibration during transportation and using.	Total fixed amplitude : 1.5mm Vibration Frequency : 10~55Hz One cycle 60 seconds to 3 directions of X,Y,Z for Each 15 minutes	3
Static electricity test	Endurance test applying the electric stress to the terminal.	VS=±600V(contact) ,±800v(air), RS=330Ω CS=150pF 10 times	—

Note1: No dew condensation to be observed.

Note2: The function test shall be conducted after 4 hours storage at the normal Temperature and humidity after remove from the test chamber.

Note3: The packing have to including into the vibration testing.

**LCM Sample Estimate Feedback Sheet**

**Module Number :** \_\_\_\_\_

**1 、 Panel Specification :**

1. Panel Type :	<input type="checkbox"/> Pass	<input type="checkbox"/> NG , _____
2. View Direction :	<input type="checkbox"/> Pass	<input type="checkbox"/> NG , _____
3. Numbers of Dots :	<input type="checkbox"/> Pass	<input type="checkbox"/> NG , _____
4. View Area :	<input type="checkbox"/> Pass	<input type="checkbox"/> NG , _____
5. Active Area :	<input type="checkbox"/> Pass	<input type="checkbox"/> NG , _____
6. Operating Temperature :	<input type="checkbox"/> Pass	<input type="checkbox"/> NG , _____
7. Storage Temperature :	<input type="checkbox"/> Pass	<input type="checkbox"/> NG , _____
8. Others :	_____	

**2 、 Mechanical Specification :**

1. PCB Size :	<input type="checkbox"/> Pass	<input type="checkbox"/> NG , _____
2. Frame Size :	<input type="checkbox"/> Pass	<input type="checkbox"/> NG , _____
3. Material of Frame :	<input type="checkbox"/> Pass	<input type="checkbox"/> NG , _____
4. Connector Position :	<input type="checkbox"/> Pass	<input type="checkbox"/> NG , _____
5. Fix Hole Position :	<input type="checkbox"/> Pass	<input type="checkbox"/> NG , _____
6. Backlight Position :	<input type="checkbox"/> Pass	<input type="checkbox"/> NG , _____
7. Thickness of PCB :	<input type="checkbox"/> Pass	<input type="checkbox"/> NG , _____
8. Height of Frame to PCB :	<input type="checkbox"/> Pass	<input type="checkbox"/> NG , _____
9. Height of Module :	<input type="checkbox"/> Pass	<input type="checkbox"/> NG , _____
10. Others :	<input type="checkbox"/> Pass	<input type="checkbox"/> NG , _____

**3 、 Relative Hole Size :**

1. Pitch of Connector :	<input type="checkbox"/> Pass	<input type="checkbox"/> NG , _____
2. Hole size of Connector :	<input type="checkbox"/> Pass	<input type="checkbox"/> NG , _____
3. Mounting Hole size :	<input type="checkbox"/> Pass	<input type="checkbox"/> NG , _____
4. Mounting Hole Type :	<input type="checkbox"/> Pass	<input type="checkbox"/> NG , _____
5. Others :	<input type="checkbox"/> Pass	<input type="checkbox"/> NG , _____

**4 、 Backlight Specification :**

1. B/L Type :	<input type="checkbox"/> Pass	<input type="checkbox"/> NG , _____
2. B/L Color :	<input type="checkbox"/> Pass	<input type="checkbox"/> NG , _____
3. B/L Driving Voltage (Reference for LED Type) :	<input type="checkbox"/> Pass	<input type="checkbox"/> NG , _____
4. B/L Driving Current :	<input type="checkbox"/> Pass	<input type="checkbox"/> NG , _____
5. Brightness of B/L :	<input type="checkbox"/> Pass	<input type="checkbox"/> NG , _____
6. B/L Solder Method :	<input type="checkbox"/> Pass	<input type="checkbox"/> NG , _____
7. Others :	<input type="checkbox"/> Pass	<input type="checkbox"/> NG , _____

>> Go to page 2 <<

Module Number : \_\_\_\_\_

**5、Electronic Characteristics of Module :**

1.Input Voltage :	<input type="checkbox"/> Pass	<input type="checkbox"/> NG , _____
2.Supply Current :	<input type="checkbox"/> Pass	<input type="checkbox"/> NG , _____
3.Driving Voltage for LCD :	<input type="checkbox"/> Pass	<input type="checkbox"/> NG , _____
4.Contrast for LCD :	<input type="checkbox"/> Pass	<input type="checkbox"/> NG , _____
5.B/L Driving Method :	<input type="checkbox"/> Pass	<input type="checkbox"/> NG , _____
6.Negative Voltage Output :	<input type="checkbox"/> Pass	<input type="checkbox"/> NG , _____
7.Interface Function :	<input type="checkbox"/> Pass	<input type="checkbox"/> NG , _____
8.LCD Uniformity :	<input type="checkbox"/> Pass	<input type="checkbox"/> NG , _____
9.ESD test :	<input type="checkbox"/> Pass	<input type="checkbox"/> NG , _____
10.Others :	<input type="checkbox"/> Pass	<input type="checkbox"/> NG , _____

**6、Summary :**

Sales signature : \_\_\_\_\_

Customer Signature : \_\_\_\_\_

Date : / /