

The information provided herein is from CONNELY Electronic Co., Ltd. and is confidential. Any disclosure to a party other than the recipient is prohibited. The intellectual properties and its rights contained herein, including but not limited to, trademarks, patents, copyrights, trade secrets, and technical know-how, are owned exclusively by CONNELY or its affiliates. Unauthorized use of this information in any format or manner. CONNELY may enforce its intellectual property rights at its own discretion; failures or delays to exercise such rights does not constitute a waiver of such rights.

NOTES:

1. SPECIFICATIONS

- . Contact Rating: 50mA at 12Vdc
- . Insulation Resistance:100MΩ min.
- . Contact Resistance:50mΩ max.
- . Dielectric Withstanding Voltage: 250V AC(rms) for 1 minute.
- . Operating Life:100,000 cycles
- . Travel:0.5±0.1mm
- . Operation Temperature Range: -25°C to +70°C

REV.	DESCRIPTION	DRAWN	CHECKED	APPROVED
A	NEW RELEASE	JLZ 11/26/18'		

- . Wave Soldering: Recommended Solder Temperature At 500°F(260°C)max. 5 Seconds
- . Hand Soldering: Use Soldering Iron Of 30 Watts,Controlled At 608°F(320°C)Approximately 2 Seconds.

2. PRODUCT NUMBER CODE:

DS1041-19 - X X X X X X X

- Operating Life
10: 100,000 cycles
- Operating force
600: 600±50gf
- Packing type
A: polybag
- Actuator color
K: Black
- Housing color
K: Black
- Profile Height(Dim H)
080:8.0mm
- No. of contacts
2: 2 pos

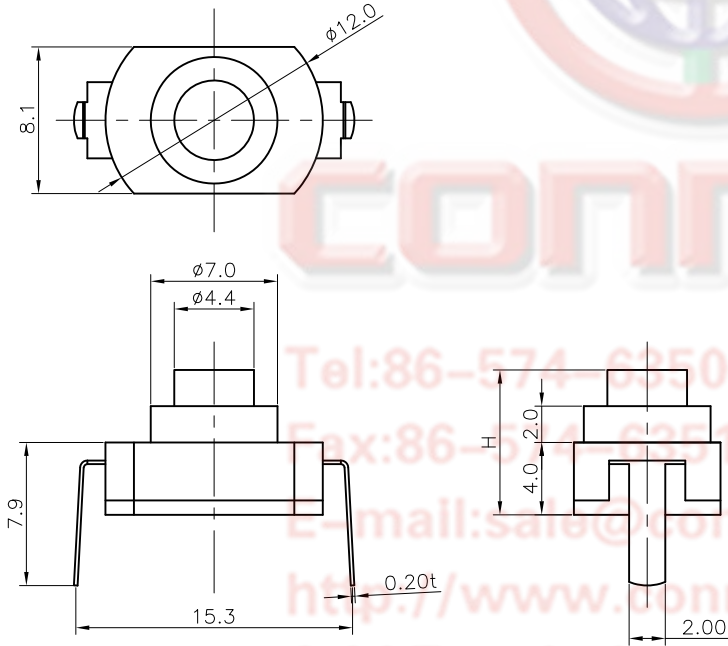

Tel:86-574-62508787
 Fax:86-574-62510817
 E-mail:sales@connfly.com
 http://www.connfly.com
 Add:East Industry Zone KuangYan
 Town Cixi Ningbo China
 P.C:315333

GENERAL TOLERANCE		ANGLE TOLERANCE		PROJECTION		TITLE	ø12*8.1mm Tact Switch	
X.	±0.60	X.	±5°	UNITS	mm		V/T 2 Positions Type	
.X	±0.38	.X	±3°	SHEET SIZE	A4	SERIES	DS1041-19 SERIES	
.XX	±0.25	.XX	±2°	晨翔电子有限公司 CONNFLY CONNELY ELECTRONIC CO. LTD				
DRAWING TYPE		CUSTOMER						
SCALE	1:1	SHEET	1 OF 1					
DRAWING NO.		C-DS1041-19-XXXXXXXX-A						