



# TAI-SAW TECHNOLOGY CO., LTD.

No. 3, Industrial 2nd Rd., Ping-Chen Industrial District,  
Taoyuan, 324, Taiwan, R.O.C.

TEL: 886-3-4690038 FAX: 886-3-4697532

E-mail: [tstsales@mail.taisaw.com](mailto:tstsales@mail.taisaw.com) Web: [www.taisaw.com](http://www.taisaw.com)

## Approval Sheet For Product Specification

Issued Date:

Product Name: SAW Resonator 803.931 MHz SMD 3.8X3.8 mm

TST Parts No.: TC0176A

Customer Parts No.: \_\_\_\_\_

Company: _____
Division: _____
Approved by : _____
Date: _____

Checked by: Vincent Liu

Approval by: Francis Chen

Date: 2002/11/12



# TAI-SAW TECHNOLOGY CO., LTD.

No. 3, Industrial 2nd Rd., Ping-Chen Industrial District,  
Taoyuan, 324, Taiwan, R.O.C.

TEL: 886-3-4690038 FAX: 886-3-4697532

E-mail: [tstsales@mail.taisaw.com](mailto:tstsales@mail.taisaw.com) Web: [www.taisaw.com](http://www.taisaw.com)

## SAW Resonator 803.931 MHz

MODEL NO.: TC0176A

REV. NO.:3

### A. FEATURES:

1. 1-Port Resonator.

### B. MAXIMUM RATING:

1. Input Power Level: 0 dBm

2. DC voltage: 12 V

3. Operating Temperature: -40°C to +85°C

4. Storage Temperature: -40°C to +85°C

### C. ELECTRICAL CHARACTERISTICS:

Characteristic	Units	Minimum	Typical	Maximum
Center frequency <b>Fr</b>	<b>MHz</b>	803.806	803.931	804.056
Insertion Loss <b>IL</b>	<b>dB</b>	-	1.5	2.5
Equivalent Elements				
Motional capacitance <b>C1</b>	<b>fF</b>	-	1.67	-
Motional inductance <b>L1</b>	<b>μH</b>	-	23.5	-
Motional resistance <b>R1</b>	<b>Ohm</b>	-	14.2	33
Parallel capacitance <b>Co</b>	<b>pF</b>	-	2.84	-
Temp.coeff.	<b>ppm/c*2</b>	-	0.032	-
Turnover To	<b>deg.C</b>	20	-	50
Package size		SMD 3.8X3.8X1.4mm		

### D. OUTLINE DRAWING:

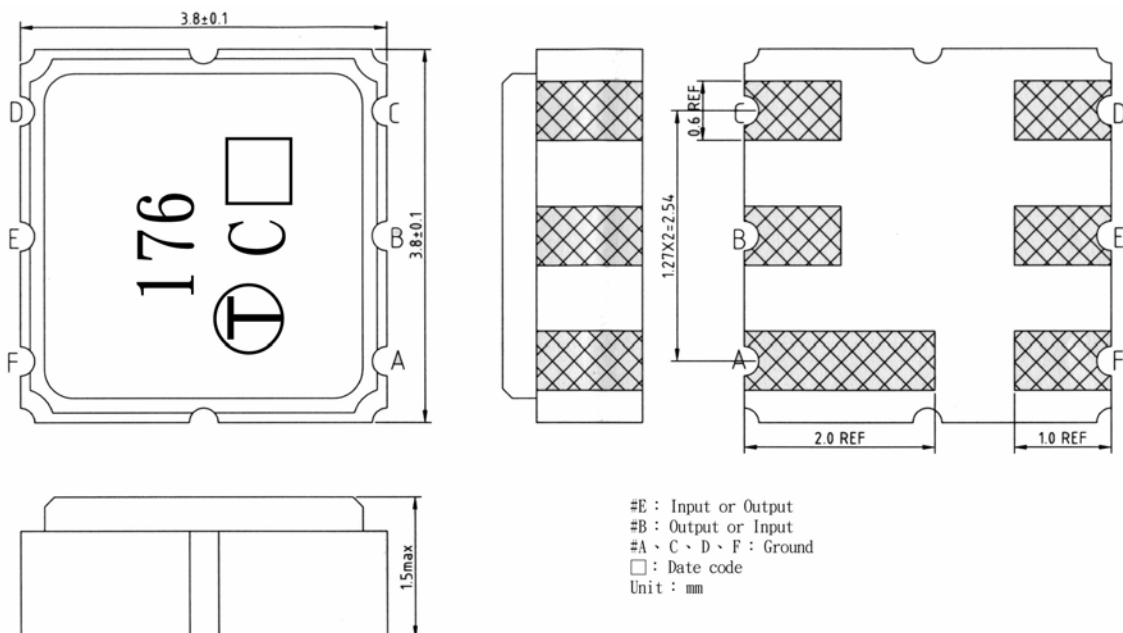

E. EQUIVALENT CIRCUIT:

One-Port Resonator:

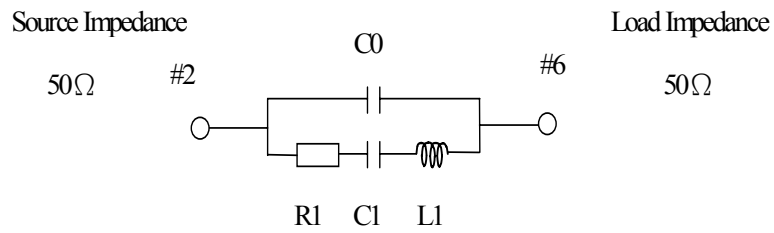

F. FREQUENCY CHARACTERISTICS:

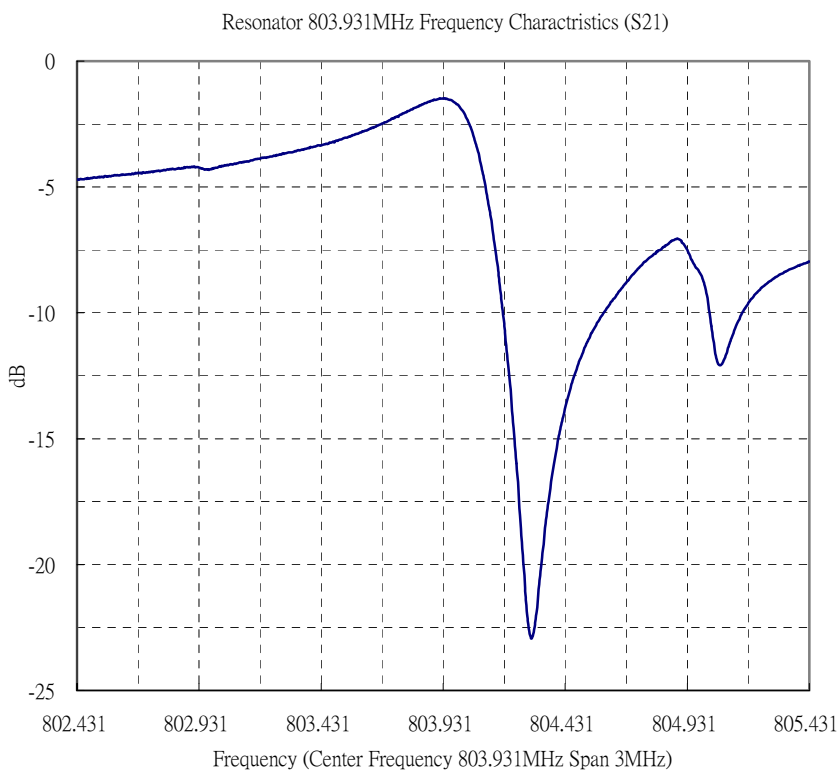

G. TEST CIRCUIT:

Network analyzer

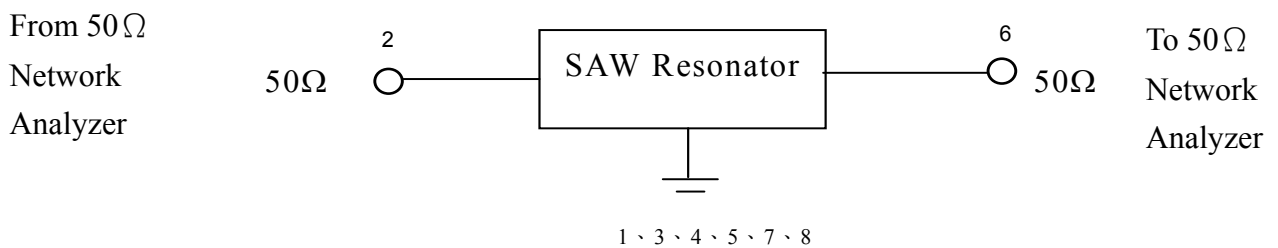

H. PACKING:

1. REEL DIMENSION

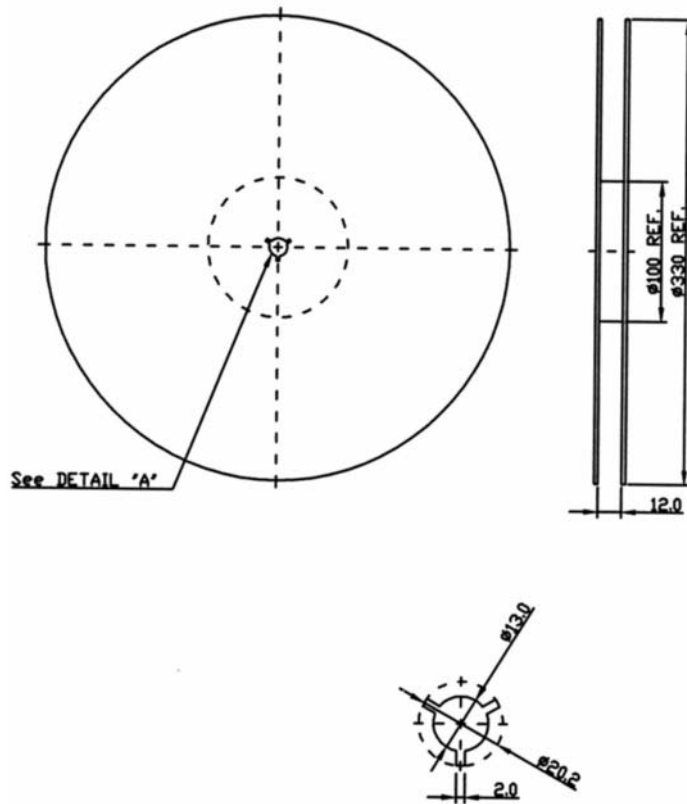

2. TAPE DIMENSION

