

TK67, %+

TK67, %+

- For general AF applications
- High collector current
- High current gain
- Low collector-emitter saturation voltage
- Complementary types: TKBC807 (PNP)

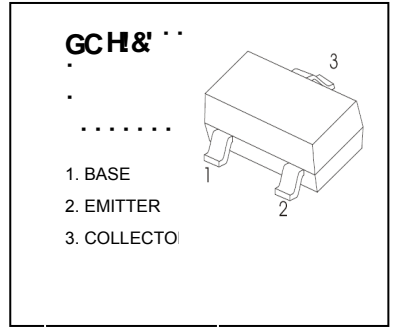

MAXIMUM RATINGS (T_a=25°C unless otherwise noted)

Symbol	Parameter	Value	Unit
V _{CB0}	Collector-Base Voltage	50	V
V _{CEO}	Collector-Emitter Voltage	45	V
V _{EBO}	Emitter-Base Voltage	5	V
I _C	Collector Current	500	mA
P _C	Collector Power Dissipation	300	mW
R _{θJA}	Thermal Resistance From Junction To Ambient	417	°C/W
T _j	Junction Temperature	150	°C
T _{stg}	Storage Temperature	55~+150	°C

TK67, %+ 5 @ 7 HF 5 @ 7 < 5 F 5 7 H9 F -GH7 G'fh1 &) °C i b`Ygg'cH Yfk jgY gdYWZ YXL`

Parameter	Symbol	Value	A in	Typ	A ax	Unit
Collector-Base Voltage	V _{CB0}	I _C = 10μA, I _E = 0	50			V
Collector-Emitter Voltage	V _{CEO}	I _C = 10mA, I _B = 0	45			V
Emitter-Base Voltage	V _{EBO}	I _E = 1μA, I _C = 0	5			V
Collector-Base Saturation Voltage	V _{CB(sat)}	V _{CE} = 45V, I _E = 0			0.1	μA
Emitter-Base Saturation Voltage	V _{EB(sat)}	V _{EB} = 4V, I _C = 0			0.1	μA
Current Gain	h _{FE}	h _{FE(1)}	V _{CE} = 1V, I _C = 100mA	100	600	
		h _{FE(2)}	V _{CE} = 1V, I _C = 500mA	40		
Collector-Emitter Saturation Voltage	V _{CE(sat)}	I _C = 500mA, I _B = 50mA			0.7	V
Base-Emitter Saturation Voltage	V _{BE(sat)}	I _C = 500mA, I _B = 50mA			1.2	V
Base-Emitter Voltage	V _{BE}	V _{CE} = 1V, I _C = 500mA			1.2	V
Output Capacitance	C _{ob}	V _{CB} = 10V, f = 1MHz		10		pF
Transition Frequency	f _T	V _{CE} = 5V, I _C = 10mA, f = 100MHz	100			MHz

TK67, %+ 5 @ 7 HF 5 @ 7 < 5 F 5 7 H9 F -GH7 G'fh1 &) °C i b`Ygg'cH Yfk jgY gdYWZ YXL`

Parameter	TK67, %+ (%)	TK67, %+ (&)	TK67, %+ (\$) (\$)
V _{CE(sat)}	0.7	0.7	0.7
V _{BE(sat)}	1.2	1.2	1.2
A _{Uf} (b)	*5	*6	*7

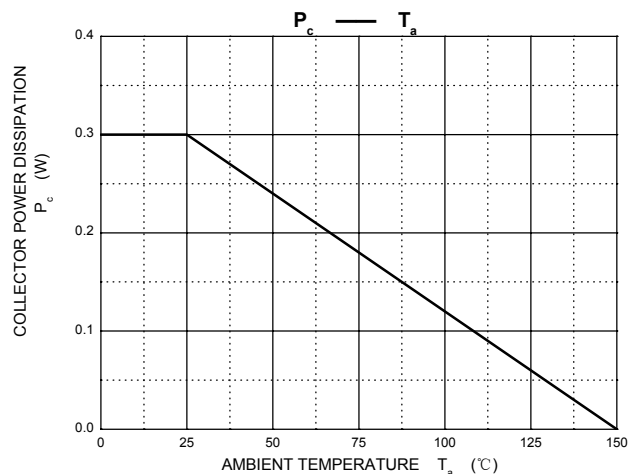
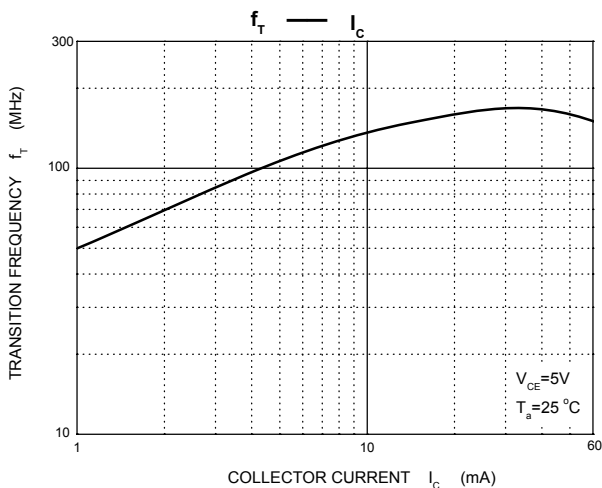
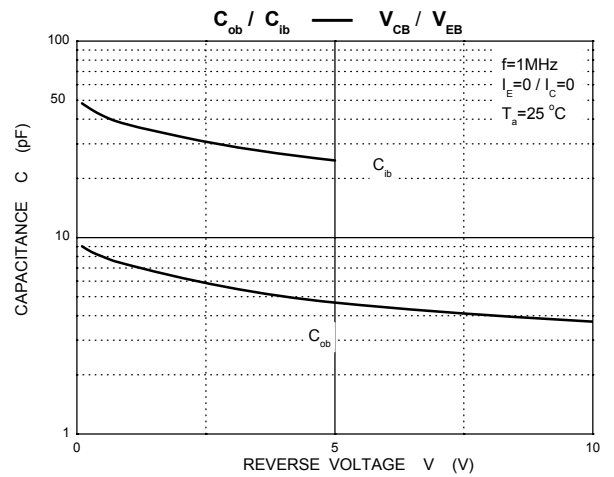
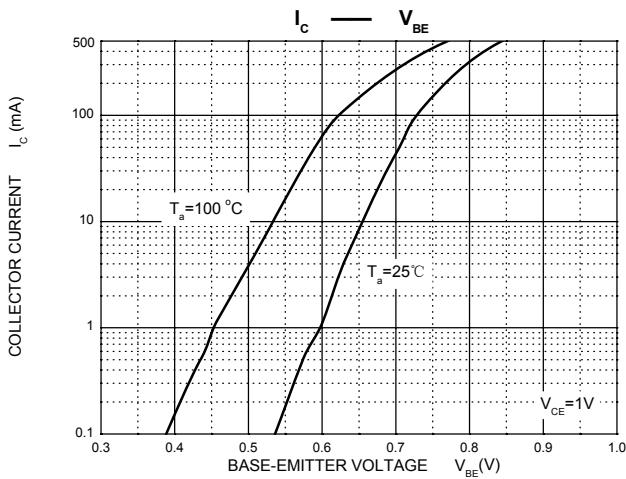
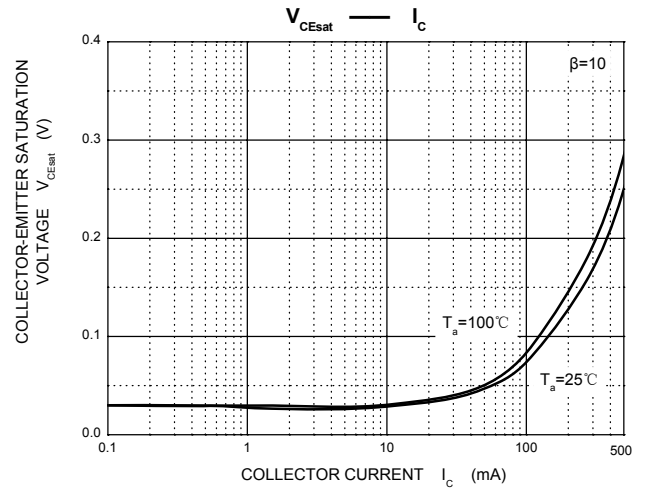
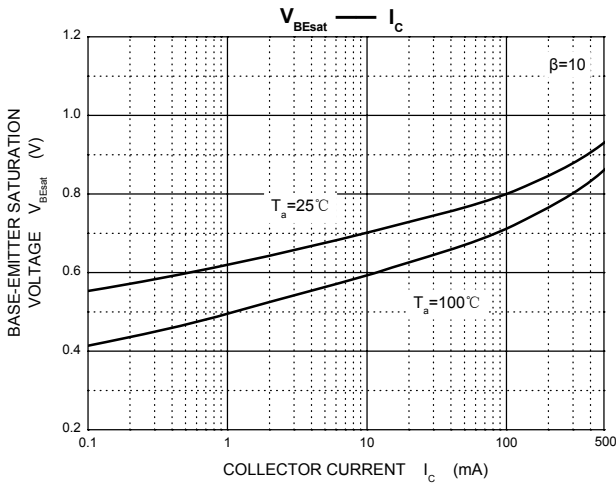
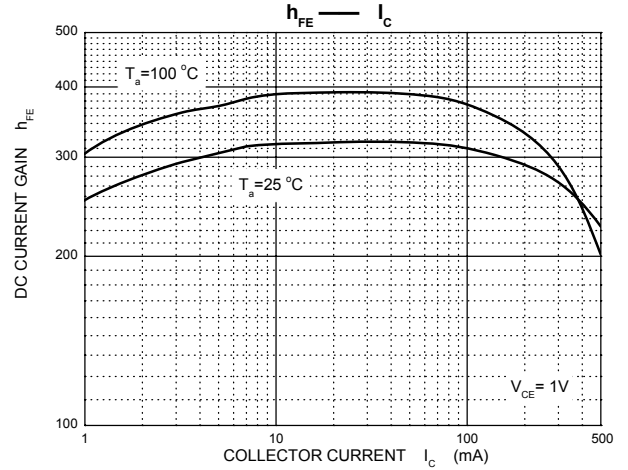
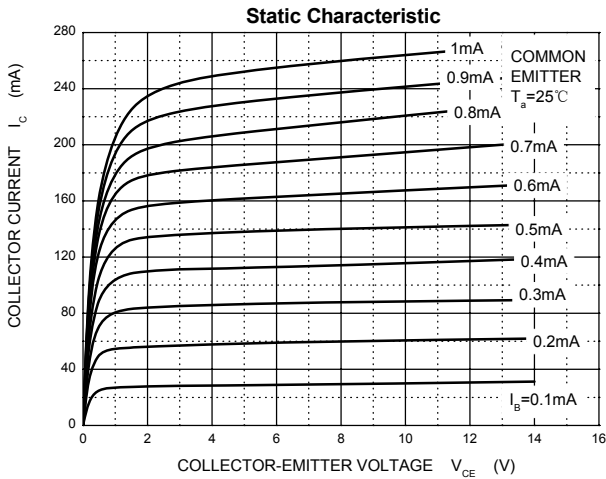

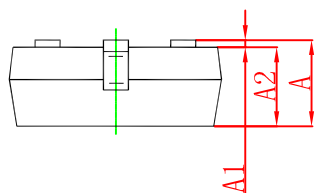
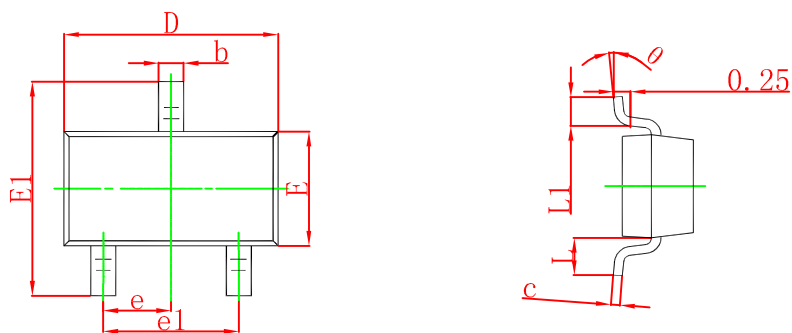

Symbol	Dimensions In Millimeters		Dimensions In Inches	
	Min	Max	Min	Max
A	0.900	1.150	0.035	0.045
A1	0.000	0.100	0.000	0.004
A2	0.900	1.050	0.035	0.041
b	0.300	0.500	0.012	0.020
c	0.080	0.150	0.003	0.006
D	2.800	3.000	0.110	0.118
E	1.200	1.400	0.047	0.055
E1	2.250	2.550	0.089	0.100
e	0.950 TYP		0.037 TYP	
e1	1.800	2.000	0.071	0.079
L	0.550 REF		0.022 REF	
L1	0.300	0.500	0.012	0.020
θ	0°	8°	0°	8°

SOT-23 Suggested Pad Layout

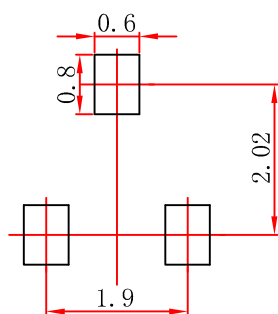

- Note:
1. Controlling dimension: in millimeters.
 2. General tolerance: $\pm 0.05\text{mm}$.
 3. The pad layout is for reference purposes only.