

This product is under development and specifications are subject to change.

Specifications for

Blanview TFT-LCD Monitor (TENTATIVE)

(10.4" SVGA 600 x RGB x 800 Landscape)

Version 0.1

(Please be sure to check the specifications latest version.)

MODEL COM104H9M11SSS

Customer's Approval

Signature :

Name :

Section :

Title :

Date :



TOPPAN INC.
Electronics Division
Ortus Subdivision

Approved by

Checked by

Prepared by

Version History

Ver.	Date	Page	Description
0.0	Jul.16,2021	-	- Tentative issue
0.1  x5	Nov.11.2021	P.10	4. Pin Assignment Change Note
		P.15	6.2 LVDS Interface Delete VD, HD in format table R2 +/-.
		P.18	Add Note
		P.23	7. Characteristics Add Rating
		P.28	11. Packing Specifications Add Packing Specifications
		P.28	APPENDIX (1.Measurement Condition (Backlight ON)) Correct Note

Contents

1. Application	4
2. Outline Specifications		
2.1 Features of the Product	5
2.2 Display Method	5
3. Dimensions and Shape		
3.1 Dimensions	7
3.2 Outward Form	8
3.3 Serial № print (S-label)	9
4. Pin Assignment	10
5. Absolute Maximum Rating	11
6. Electrical Characteristics		
6.1 DC Characteristics	12
6.2 LVDS Interface	13
6.3 Input Timing Specifications	16
6.4 Power ON/OFF Sequence	17
7. Characteristics		
7.1 Optical Characteristics	18
8. Inspection Criteria		
8.1 Inspection Condition	19
8.2 Light Method	19
8.3 Definition Of Inspection Area	19
9. Item and Criteria		
9.1 Visual inspection criterion in cosmetic	20
9.2 Defective Display and Screen Quality	21
10. Reliability Test	22
11. Packing Specifications	23
12. Handling Instruction		
12.1 Cautions for Handling LCD panels	24
12.2 Precautions for Handling	25
12.3 Precautions for Operation	25
12.4 Storage Condition for Shipping Cartons	26
12.5 Precautions for Peeling off the Protective film	27
12.6 Warranty	27
APPENDIX	28

1. Application

This Specification is applicable to 264.0 mm (10.4 inch) Blanview TFT-LCD monitor for non-military use.

- ◎ TOPPAN makes no warranty or assume no liability that use of this Product and/or any information including drawings in this Specification by Purchaser is not infringing any patent or other intellectual property rights owned by third parties, and TOPPAN shall not grant to Purchaser any right to use any patent or other intellectual property rights owned by third parties. Since this Specification contains TOPPAN's confidential information and copy right, Purchaser shall use them with high degree of care to prevent any unauthorized use, disclosure, duplication, publication or dissemination of TOPPAN's confidential information and copy right.
- ◎ If Purchaser intends to use this Products for an application which requires higher level of reliability and/or safety in functionality and/or accuracy such as transport equipment (aircraft, train, automobile, etc.), disaster-prevention/security equipment or various safety equipment, Purchaser shall consult TOPPAN on such use in advance.
- ◎ This Product shall not be used for application which requires extremely higher level of reliability and/or safety such as aerospace equipment, telecommunication equipment for trunk lines, control equipment for nuclear facilities or life-support medical equipment.
- ◎ It must be noted as an mechanical design manner, especial attention in housing design to prevent arcuation/flexure caused by stress to the LCD module shall be considered.
- ◎ TOPPAN assumes no liability for any damage resulting from misuse, abuse, and/or miss-operation of the Product deviating from the operating conditions and precautions described in the Specification.
- ◎ It shall be mutually conferred if nonconforming defect which result from unspecified cause in this specification arises.
- ◎ If any issue arises as to information provided in this Specification or any other information, TOPPAN and Purchaser shall discuss them in good faith and seek solution.
- ◎ TOPPAN assumes no liability for defects such as electrostatic discharge failure occurred during peeling off the protective film or Purchaser's assembly process.
- ◎ This Product is compatible for RoHS(2.0) directive.

Object substance	Maximum content [ppm]
Cadmium and its compound	100
Hexavalent Chromium Compound	1000
Lead & Lead compound	1000
Mercury & Mercury compound	1000
Polybrominated biphenyl series (PBB series)	1000
Polybrominated biphenyl ether series (PBDE series)	1000
Bis(2-ethylhexyl)phthalate series(DEHP series)	1000
Butyl benzyl phthalate series(BBP series)	1000
Dibutyl phthalate series(DBP series)	1000
Diisobutyl phthalate series(DIBP series)	1000

<Features of Blanview>

- Backlight power consumption required to assure visibility. (equivalent to 3.5"QVGA)

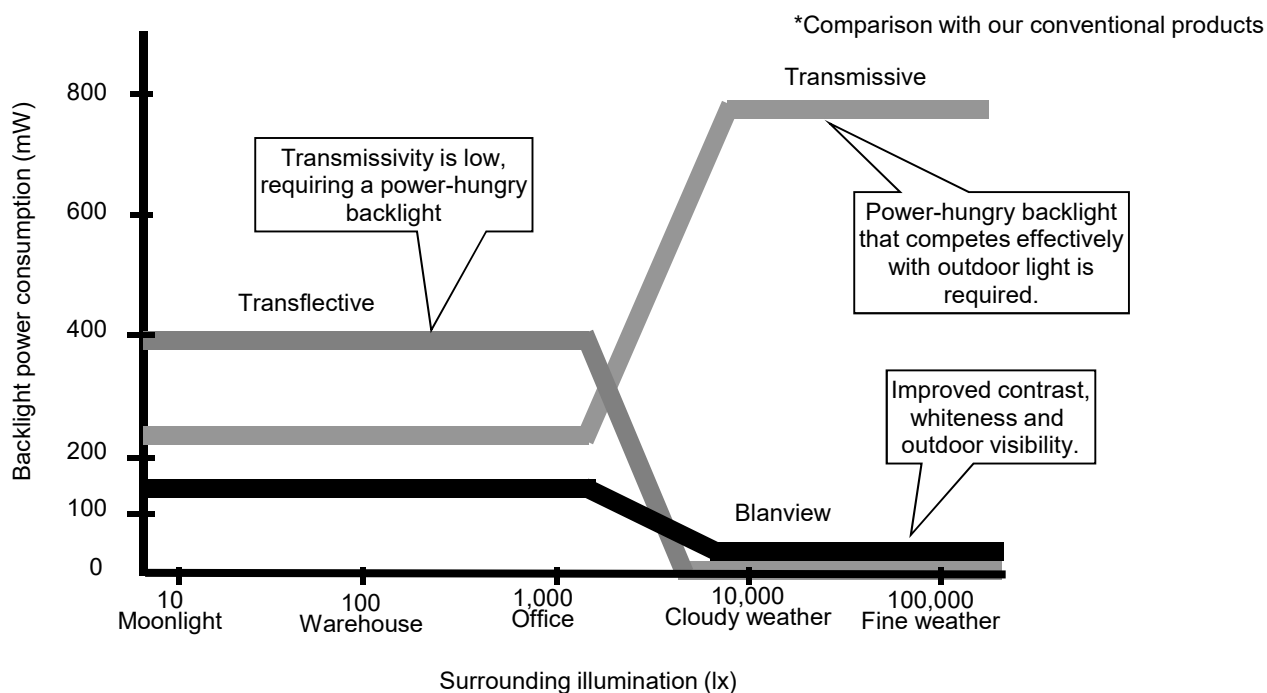

- Contrast characteristics under 100,000lx. (same condition as direct sunlight.)

With better contrast (higher contrast ratio), Blanview TFT-LCD has the best outdoor readability in three different types of TFT-LCD.

Below chart shows contrast value against panel surface brightness. (Horizontal: Panel surface brightness/ Vertical: Contrast value) LCD panel has enough outdoor readability above our Standard line. (TOPPAN criteria)

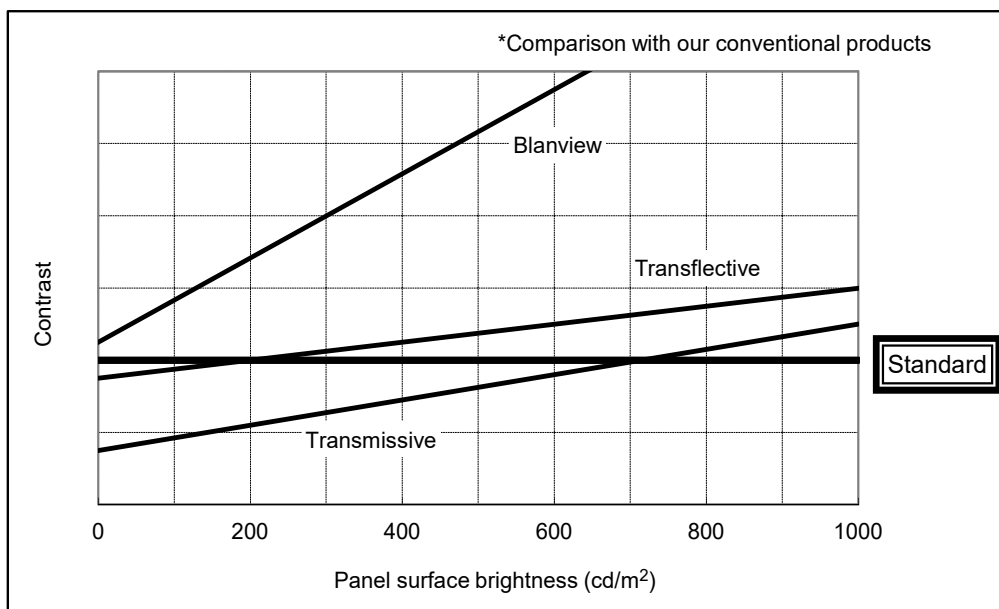

3. Dimensions and Shape

3.1 Dimensions

Items	Specifications	Unit	Remarks
Outline dimensions	(230.0)[H] × (180.2)[V] × (11.0)[D]	mm	
Active area	211.2[H] × 158.4[V]	mm	Diagonal 264.0 mm
Number of dots	2400[H] × 600[V]	dot	
Dot pitch	88.0[H] × 246.0[V]	um	
Weight	T.B.D.	g	

3.2 Outward form

(8/30)
21TLM019
Issue:Nov.11,2021

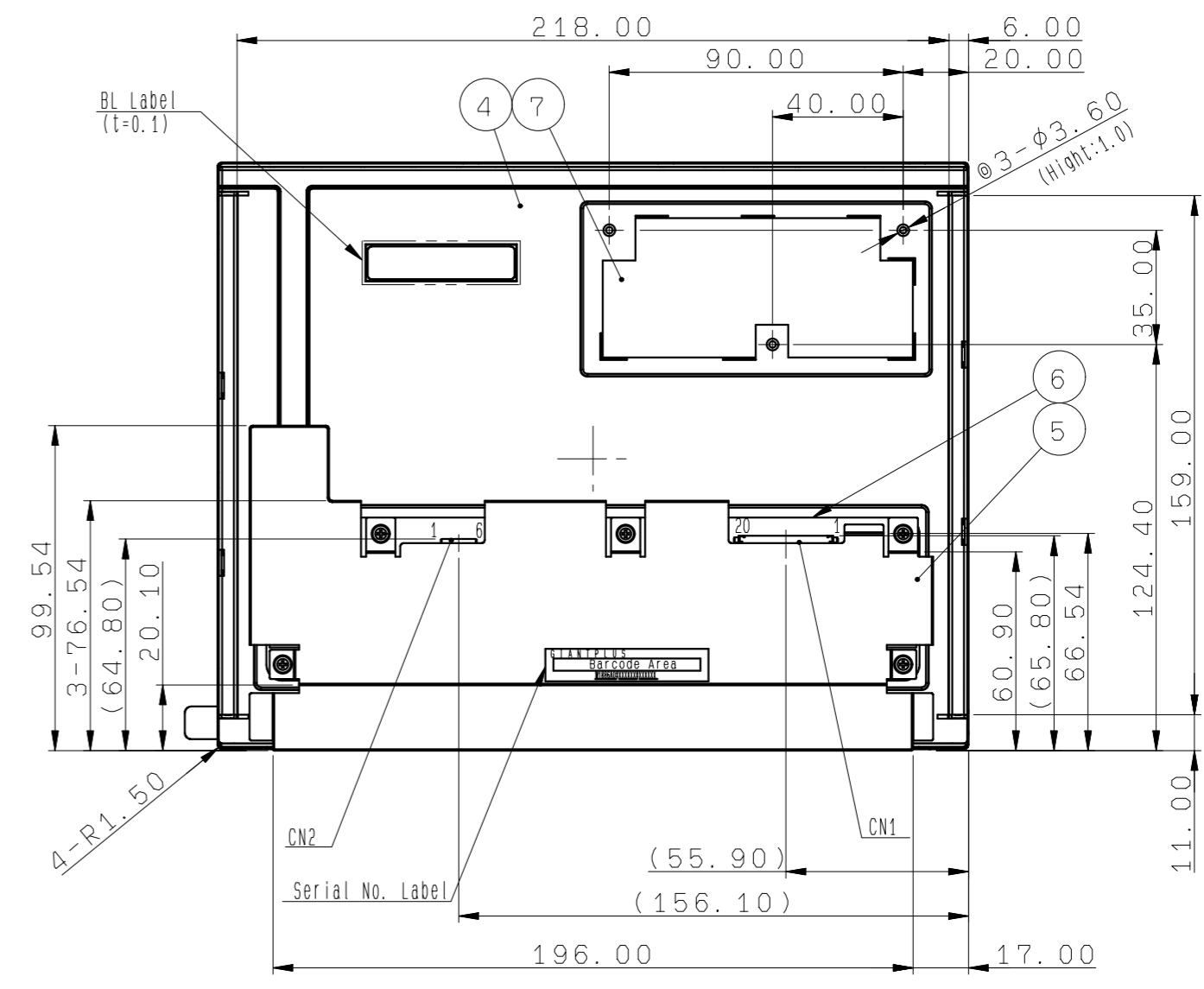
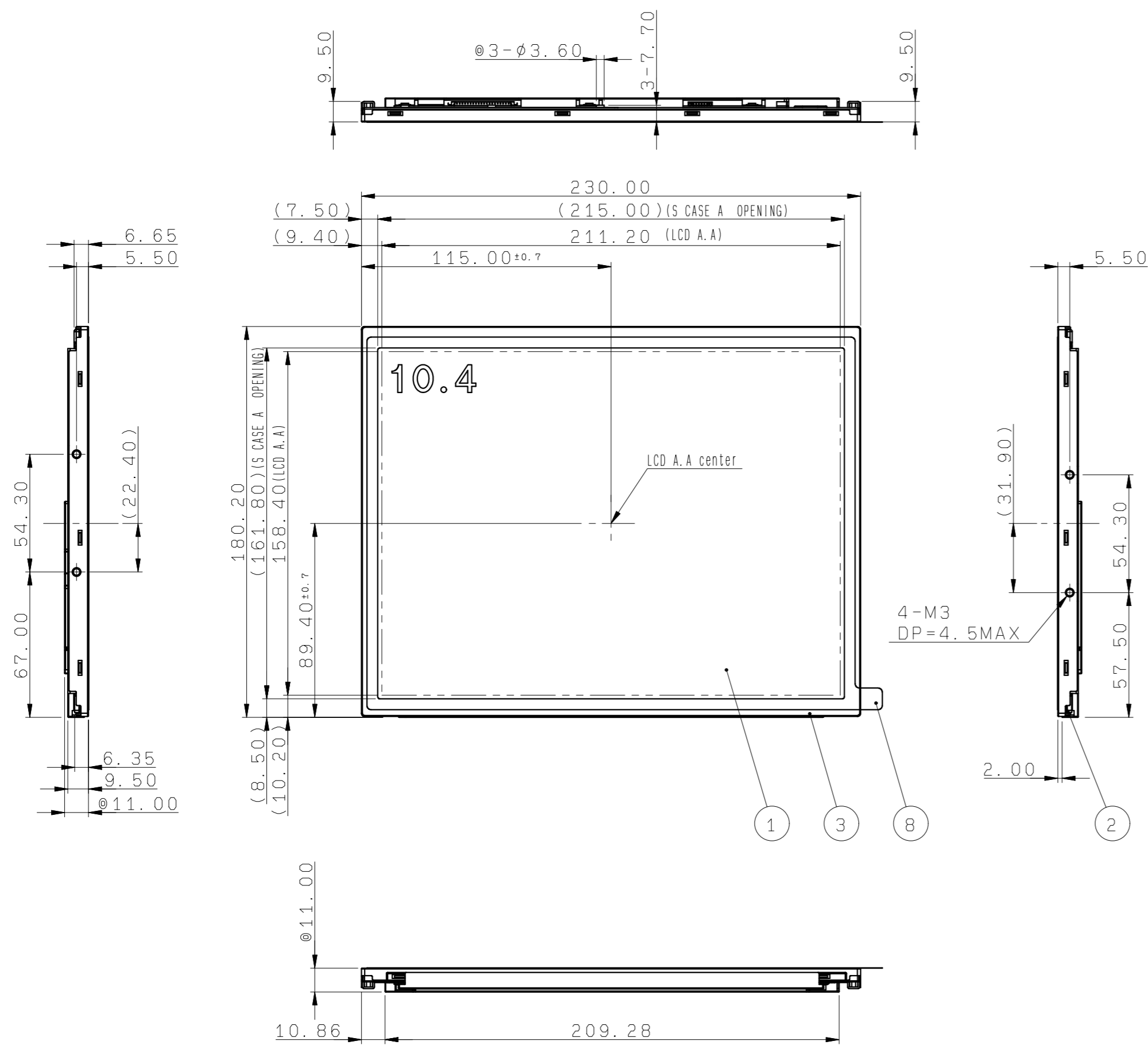

NOTE : 1.Connector :
CN1:F1-SEB20P-HFE(JAE).
CN2:F1-56P-HFE(JAE).

Protection Film	8			
Insulation Film	7			
PCB B	6			
S CASE E	5		SUS t=0.3	
S CASE C	4		AL t=0.8	
S CASE A	3		SUS t=0.3	
FRAME	2		PC	
TFT-LCD PANEL	1		Glass substrate thickness=0.5±0.5t	
PART NAME	ITEM	PART CODE	MODEL NUMBER	REMARK
APPROVED 尾木幹生	GENERAL TOLERANCE ±0.5	SCALE 1/2	UNIT mm	TOPPAN TOPPAN INC. DO NOT DUPLICATE, CONFIDENTIAL AND PROPRIETARY
CHECKED 加藤真一	ISSUE (Y-M-D) 21:10:29	MODEL COM104H9M11S**		
CHECKED	NAME			
DESIGN 前田創				
DRAW 前田創				
			OUTLINE-G9M11	DRAWING No. RJD602397D201
				REV. SHEET DIV. /

3.3 Serial label (S-label)

3.3.1 Display items

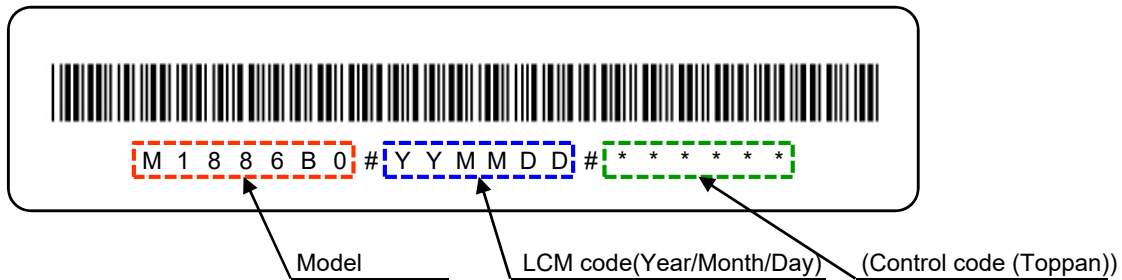

3.3.2 Location of Serial Label (S-label)

Refer to 3.2 "Outward Form".

4. Pin Assignment

**LCD_CN**

No.	Symbol	Details
1	VCC	Power supply (3.3V)
2	VCC	Power supply (3.3V)
3	GND	Ground
4	GND	Ground
5	R0-	LVDS DATA0(-)
6	R0+	LVDS DATA0(+)
7	GND	Ground
8	R1-	LVDS DATA1(-)
9	R1+	LVDS DATA1(+)
10	GND	Ground
11	R2-	LVDS DATA2(-)
12	R2+	LVDS DATA2(+)
13	GND	Ground
14	CLK-	LVDS CLK(-)
15	CLK+	LVDS CLK(+)
16	GND	Ground
17	R3-	LVDS DATA3(-) *Note
18	R3+	LVDS DATA3(+) *Note
19	MODE	VESA/JEIDA switching terminal (Low: 8bit_JEIDA or 6bit_JEIDA / High: 8bit_VESA)
20	SC	Display direction switching (Low: Normal display, High: Reverse display)

- Used connector: 20186-020E-11F (I-PEX) or FI-SEB20P-HFE (JAE)
- Corresponding connector: 20197-*20U-F (I-PEX) or FI-S20S[for discrete Wire], FI-SE20ME[for FPC] (JAE)

Note) For 6-bits input, set MODE = 0 (JEIDA) and set pin numbers 17, 18 as the following recommended inputs.

- Enter the Low data of the LVDS transmitter in 17 and 18.
- or
- Connect pin 17 to VCC via 680Ω and pin 18 to GND via 620Ω.

BL_CN

No.	Symbol	Details	Remark
1	VL	Backlight Voltage (12V)	
2	VL	Backlight Voltage (12V)	
3	GNDL	Ground	
4	GNDL	Ground	
5	BLEN	Backlight ON-OFF	High: ON Low: OFF
6	VPDIM	Light Dimmer Control (PWM) input	High active

- Used connector: FI-S6P-HFE (JAE)
- Corresponding connector: FI-S6S (JAE)

- Please make sure to check a consistency between pin assignment in "3.2 Outward Form" and your connector pin assignment when designing your circuit.
Inconsistency in input signal assignment may cause a malfunction.

5. Absolute Maximum Rating

Item	Symbol	Rating		Unit
		MIN	MAX	
LCD Supply Voltage	VCC	-0.3	4.0	V
Input Voltage for Logic	VI	-0.3	VCC+0.3	V
Backlight Power Supply Input Voltage	VL	-0.3	14.0	V
Backlight ON-OFF	BLEN	-0.3	14.0	V
Light Dimmer Control (PWM) input Voltage	VPDIM	-0.3	5.75	V
Operational temperature range Note1	Top	-30	70	°C
Storage temperature range	Tstg	-30	80	°C

Note1: Panel surface temperature

6. Electrical Characteristics

6.1 DC Characteristics

6.1.1 LCD Display Module

(Unless otherwise noted, Ta=25 °C, VCC=3.3V, GND=0V)

Item	Symbol	Condition	Rating			Unit	Applicable terminal
			MIN	TYP	MAX		
LCD Supply Voltage	VCC		(3.0)	3.3	(3.6)	V	VCC
LCD operating current	ICC		-	(248)	(496)	mA	VCC
Input Voltage for Logic	LCD_VIH		0.8×VCC	-	VCC	V	MODE, SC
	LCD_VIL		0	-	0.2×VCC	V	MODE, SC

6.1.2 Backlight

(Unless otherwise noted, Ta=25 °C, VL=12V, GND=0V)

Item	Symbol	Condition	Rating			Unit	Applicable terminal
			MIN	TYP	MAX		
Supply Input Voltage	VL		(10.8)	12.0	(13.2)	V	VL
Supply Input Current	IL		--	(241)	(482)	mA	VL
Backlight ON-OFF	High_BLEN	ON	(2.5)	--	(VL)	V	BLEN
	Low_BLEN	OFF	0	--	(0.4)	V	
Light Dimmer Control PWM Input Voltage	Low_VPDIM	ON	(2.5)	--	(5.5)	V	VPDIM
	High_VPDIM	OFF	0	--	(0.4)	V	
PWM frequency	f PDIM		200	500	1000	Hz	VPDIM
Dimming Rate (PWM Duty)	DR	VL=12.0V	(5)	--	100	%	VPDIM
Estimated Life of LED Note	LL	IL=(45)mA Ta=25°C	--	(TBD)	--	hrs	

- Note:
- The lifetime of the LED is defined as a period till the brightness of the LED decreases to the half of its initial value.
 - This figure is given as a reference purpose only, and not as a guarantee.
 - This figure is estimated for an LED operating alone. As the performance of an LED may differ when assembled as a monitor together with a TFT panel due to different environmental temperature.
 - Estimated lifetime could vary on a different temperature and usually higher temperature could reduce the life significantly.

6.2 LVDS Interface

6.2.1 LVDS DC Characteristics

(Unless otherwise noted, $T_a=25\text{ }^\circ\text{C}$, $V_{CC}=3.3\text{V}$, $GND=0\text{V}$)

Item	Symbol	Condition	Rating			Unit	Applicable terminal
			MIN	TYP	MAX		
Differential input high threshold	Rxvth	$R_{XVCM}=1.2\text{V}$	-	-	0.1	V	CLK+, CLK-, R0+, R0-, R1+, R1-, R2+, R2-, R3+, R3-
Differential input low threshold	Rxvtl		-0.1	-	-	V	
Differential input Common-mode voltage	Rxvcm		0.6	1.2	$2.4- V_{ID} /2$	V	
Differential input voltage	$ V_{ID} $		0.2	0.4	0.6	V	
Differential input leakage current	R_{VXliz}		-10	-	10	μA	

Single end signals

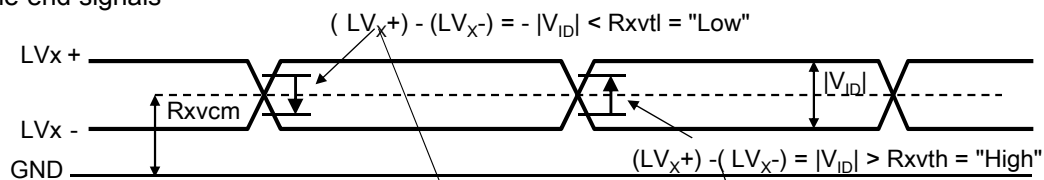

Differential signals

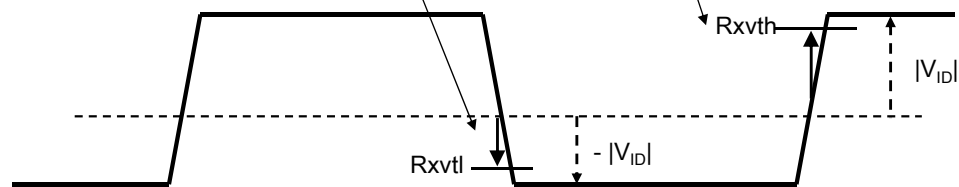

6.2.2 LVDS AC Characteristics

(Unless otherwise noted, $T_a=25\text{ }^\circ\text{C}$, $V_{CC}=3.3\text{V}$, $GND=0\text{V}$)

Item	Symbol	Rating			Unit	
		MIN	TYP	MAX		
CLK Frequency	f clk	20	-	80	MHz	
Clock period	Tc	12.5	-	50	ns	
1 data bit time	UI	-	1/7	-	Tc	
CLK High level Width	T chw	-	4	-	UI	
CLK Low level Width	T clw	-	3	-	UI	
Position 1	Tpos_1	-0.25	0	0.25	UI	
Position 0	Tpos_0	0.75	1	1.25	UI	
Position 6	Tpos_6	1.75	2	2.25	UI	
Position 5	Tpos_5	2.75	3	3.25	UI	
Position 4	Tpos_4	3.75	4	4.25	UI	
Position 3	Tpos_3	4.75	5	5.25	UI	
Position 2	Tpos_2	5.75	6	6.25	UI	
PLL wake-up time	TenPLL	-	-	150	us	

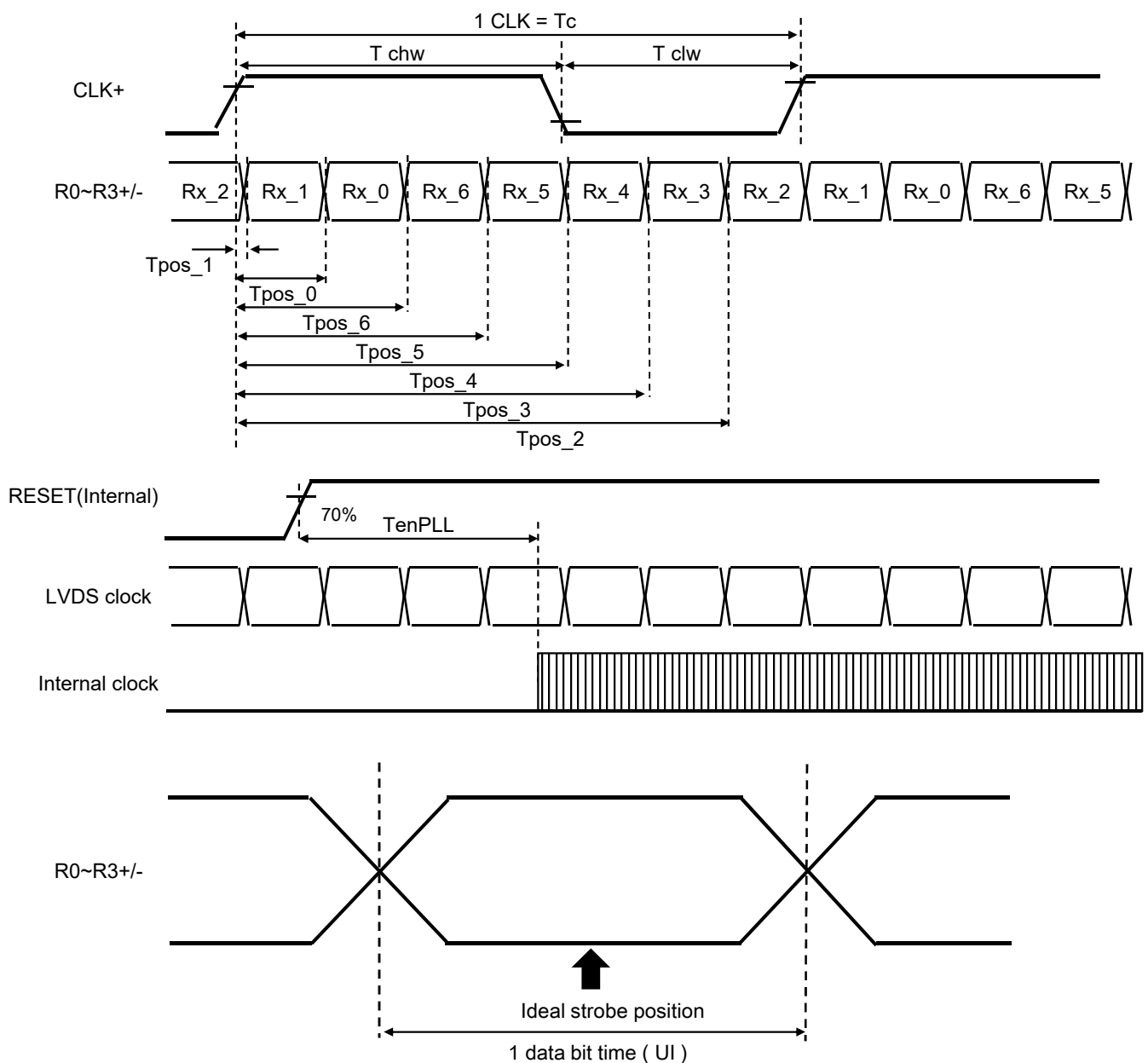

6.2.3 Input Data Format



VESA Format 8bit (MODE = High)

* (MSB : R[7],G[7],B[7])

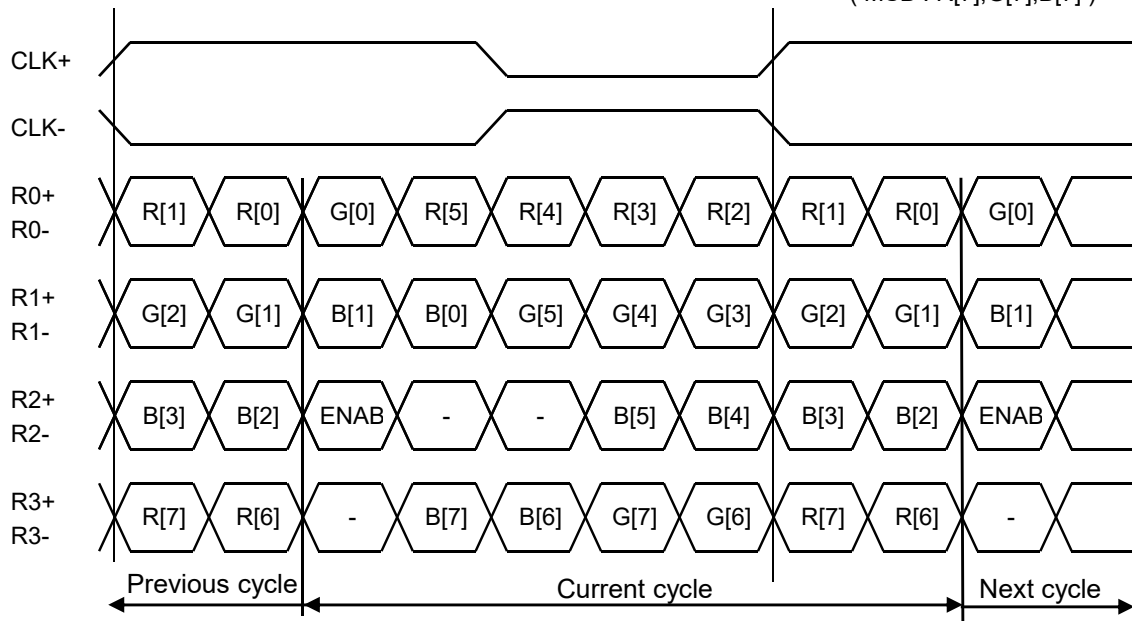

JEIDA Format 8bit (MODE = Low)

* (MSB : R[7],G[7],B[7])

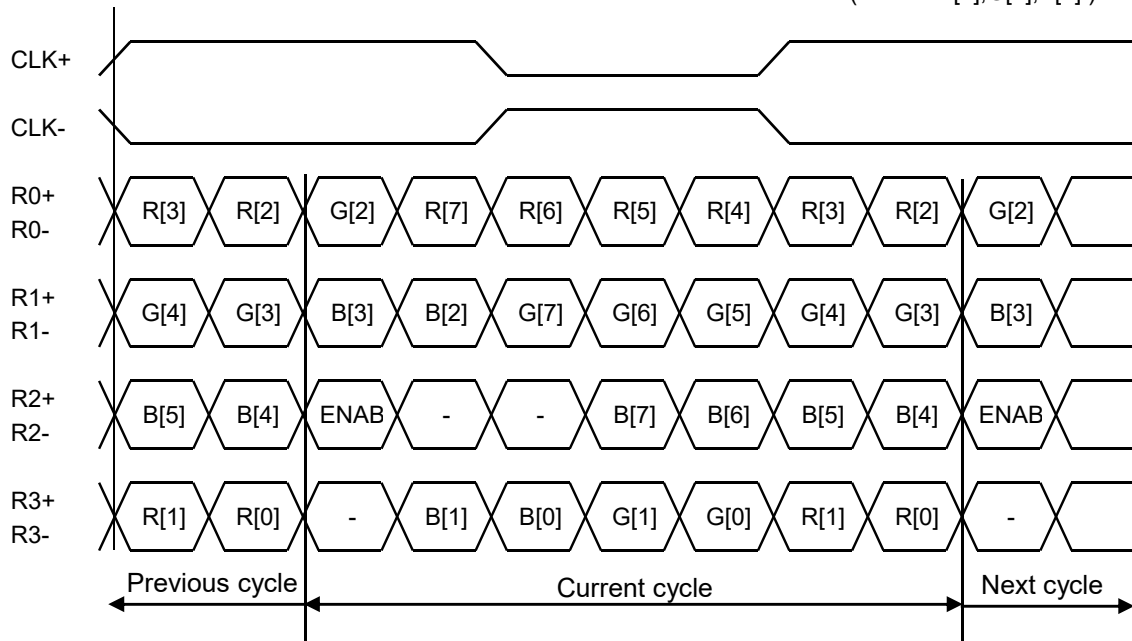

Note) For 6-bits input, MSB : R[7],G[7],B[7] and LSB : R[2],G[2],B[2].

6.3 Input Timing Specifications

Item	Symbol	Rating			Unit	Signal (*)	
		MIN	TYP	MAX			
CLK frequency	fCLK	(35)	40	(42)	MHz	CLK	
Vertical	Frequency	fVD	(55)	60	(64.2)	Hz	VD,ENAB
	Period	t _v	(613)	628	-	H	R[7:0],G[7:0],B[7:0]
	Blanking Time	t _{vb}	(13)	28	-	H	
	Active Time	t _{vdp}	600			H	
Horizontal	Frequency	fHD	(35.2)	37.9	(39.2)	kHz	CLK,HD,ENAB
	Period	t _h	(826)	1056	-	CLK	R[7:0],G[7:0],B[7:0]
	Blanking Time	t _{hb}	(26)	256	-	CLK	
	ENAB pulse width	t _{enp}	800			CLK	
	Active Time	t _{hdp}	800			CLK	

(*) Input terminals are (R0 +/-, R1 +/-, R2 +/-, R3 +/-, CLK +/-).

<Vertical timing>

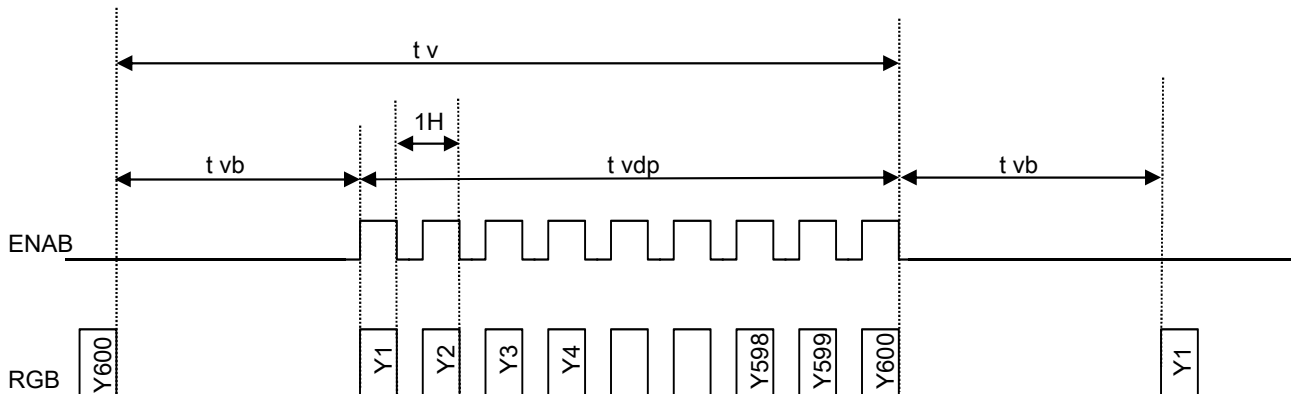

<Horizontal timing>

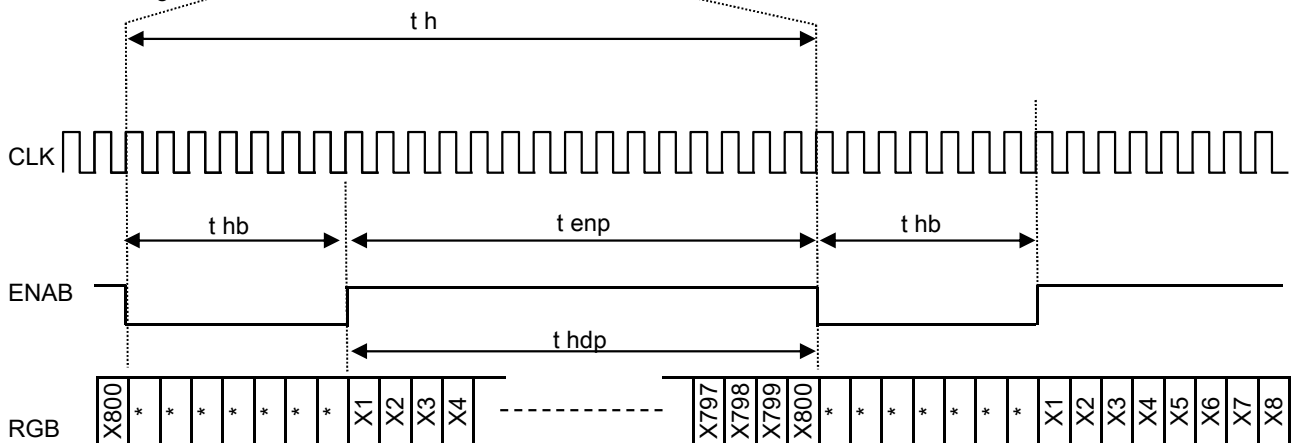

6.4 Power ON/OFF Sequence

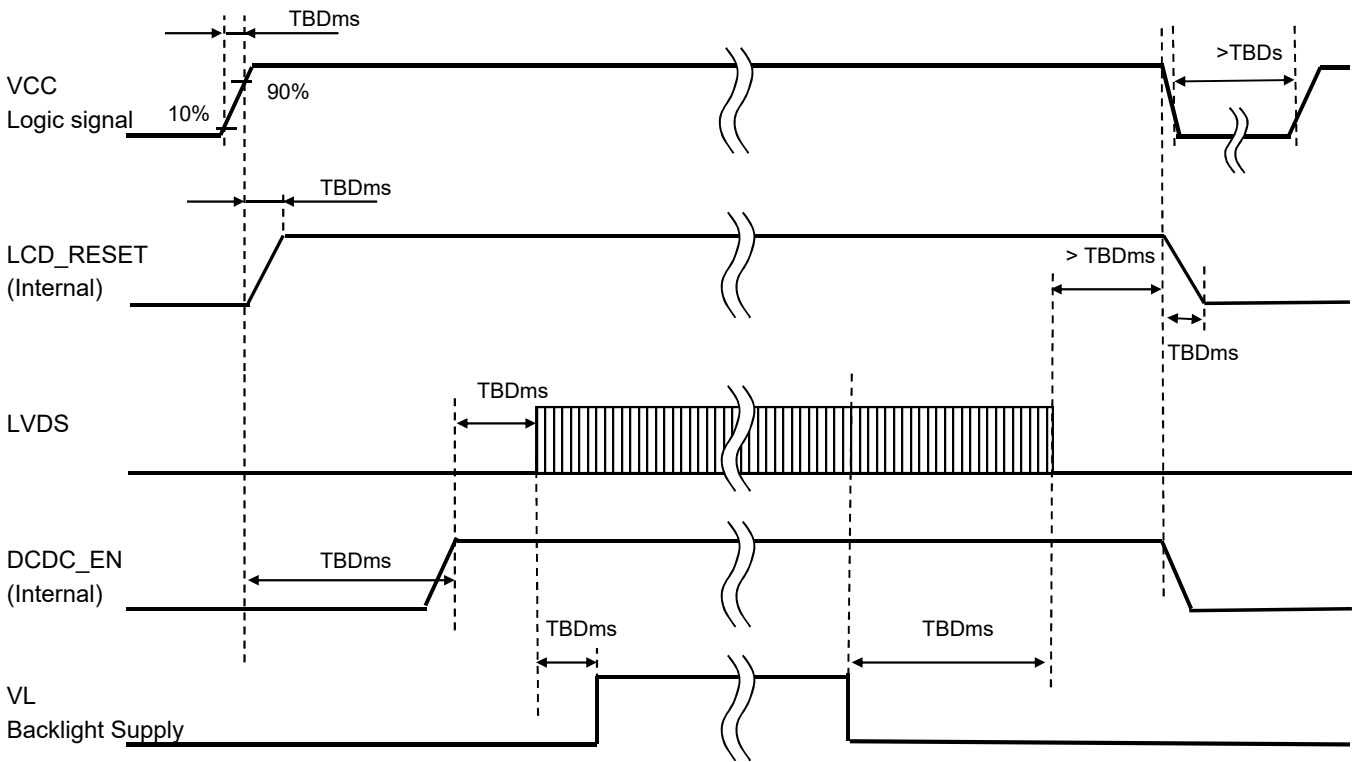

7. Characteristics



7.1 Optical Characteristics

(Measurement Condition)

Measuring instruments: CS2000 (KONICA MINOLTA), LCD7200 (OTSUKA ELECTRONICS), EZcontrastXL88 (ELDIM)

Driving condition: VCC=3.3V, GND=0V, Optimized VCOMDC

Backlight: VL=12.0V, (IL= (45.0) mA)

Measured temperature: Ta = 25°C

Item		Symbol	Condition	MIN	TYP	MAX	Unit	Note №	Remark
Response time	Rise time	TON	[Data]= 00h → FFh → 00h	-	-	40	ms	1	
	+ Fall time	TOFF							
Contrast ratio	Backlight ON	CR	[Data]= FFh / 00h	650	1000	-		2	
	Backlight OFF			-	(TBD)	-			
Viewing angle	Left	θL	[Data]= FFh / 00h CR ≥ 10	85	-	-	deg	3	
	Right	θR		85	-	-	deg		
	Up	φU		85	-	-	deg		
	Down	φD		85	-	-	deg		
White Chromaticity		x	[Data]= FFh	0.26	0.31	0.36		4	
		y		0.28	0.33	0.38			
Center Brightness			[Data]= FFh	450	650	-	cd/m ²	5	
Brightness distribution			[Data]= FFh	70	-	-	%	6	

* Note number 1 to 6: Refer to the APPENDIX of "Reference Method for Measuring Optical Characteristics".

8. Inspection Criteria

8.1 Inspection Condition

8.1.1 Environmental conditions

The environmental conditions for inspection shall be as follows

Room temperature: $23 \pm 5^{\circ}\text{C}$

Humidity: $50 \pm 20\% \text{RH}$

8.1.2 The external visual inspection

With a single 1000 ± 200 lux fluorescent lamp as the light source, the inspection was in the distance of 30cm or more from the LCD to the inspector's eyes.

8.2 Light Method

Environment lamp under 1000 ± 200 lux,
Viewing direction for inspection over 300mm.

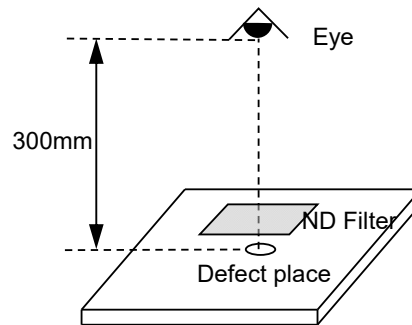

8.3 Definition Of Inspection Area

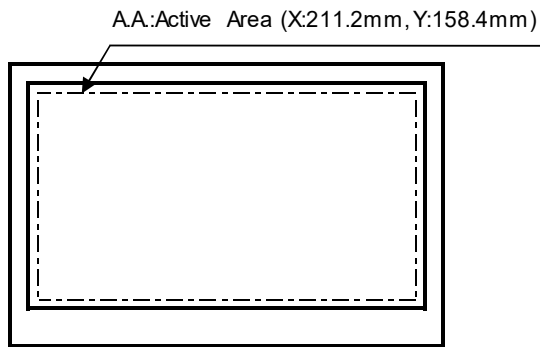

9. Item and Criteria

9.1 Visual inspection criterion in cosmetic

9.1.1 LCM appearance defect with in A.A

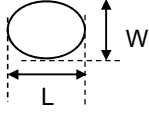
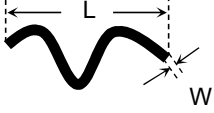
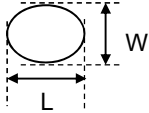
Item	Criteria		
Round type	Spec	Permissible Q'ty	$\phi = (L + W) / 2$ L : Length W : Width 
	$\phi < 0.15\text{mm}$	Disregard	
	$0.15\text{mm} \leq \phi \leq 0.30\text{mm}$	3	
	$0.30\text{mm} < \phi$	0	
Liner type	Spec	Permissible Q'ty	L : Length W : Width 
	$L \leq 3.0\text{mm}$ and $W \leq 0.05\text{mm}$	Disregard	
	$L \leq 3.0\text{m}$ and $0.05\text{mm} < W \leq 0.10\text{mm}$	3	
	$3.0\text{mm} < L$ or $0.10\text{mm} < W$	0	
Polarizer Bubble	Spec	Permissible Q'ty	$\phi = (L + W) / 2$ L : Length W : Width 
	$\phi < 0.15\text{mm}$	Disregard	
	$0.15\text{mm} \leq \phi \leq 0.30\text{mm}$	3	
	$0.30\text{mm} < \phi$	0	
Polarizer Dent	Spec	Permissible Q'ty	
	$\phi < 0.15\text{mm}$	Disregard	
	$0.15\text{mm} \leq \phi \leq 0.30\text{mm}$	3	
	$0.30\text{mm} < \phi$	0	

9.1.2 Others

Item	Criteria
Copper peeling	Reject
No insulation film	Reject

9.2 Defective Display and Screen Quality

Defective Display	Line defect	Black, white or color line, 3 or more neighboring defective dots	Reject	
				
	Dot defect	Uneven brightness on dot-by-dot base due to defective TFT or CF, or dust is counted as dot defect	Refer to Table 1 Note1) 1dot : 1R / 1G / 1B Note2) Point defect area $\geq 1/2$ dot.	
Item				
Screen Quality	Round type	Spec	Permissible Q'ty	
		$\phi < 0.15\text{mm}$	Disregard	
		$0.15\text{mm} \leq \phi \leq 0.30\text{mm}$	3	
		$0.30\text{mm} < \phi$	0	$\phi = (L + W) / 2$ L : Length W : Width 
	Liner type	Spec	Permissible Q'ty	L : Length W : Width 
		$L \leq 3.0\text{mm}$ and $W \leq 0.05\text{mm}$	Disregard	
$L \leq 3.0\text{mm}$ and $0.05\text{mm} < W \leq 0.10\text{mm}$		3		
	$3.0\text{mm} < L$ or $0.10\text{mm} < W$	0		
Mura	Black		Invisible through 10% ND filter	
	White / Gray / R / G / B		Invisible through 5% ND filter	

Table 1

Item	Zone		Total
	A	B	
Bright dot	1	2	3
Dark dot	2	3	3
Bright dot + Dark dot	3	4	5
Two adjacent dot	Reject		-

(Zone)

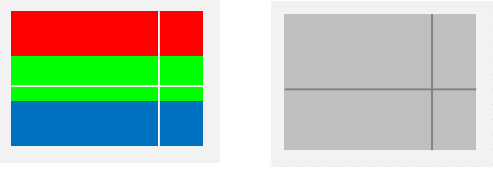
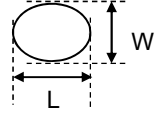
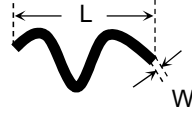
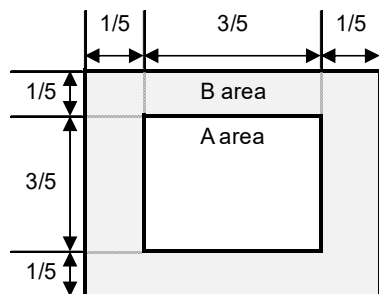

Division of A and B areas

B area: Active area

Dimensional ratio between A and B areas: 1: 3: 1

(Refer to the left figure)

10. Reliability Test

Test Item		Test condition		Number of failures / Number of examinations
Durability test	High temperature storage	Ta = 80°C	240hrs	TBD
	Low temperature storage	Ta = -30°C	240hrs	TBD
	High temperature and High humidity storage	Ta = 60°C, RH = 90% non condensing	240hrs	※ TBD
	High temperature operation	Tp = 70°C	240hrs	TBD
	Low temperature operation	Tp = -30°C	240hrs	TBD
	High temperature and High humidity operation	Tp = 40°C, RH = 90% non condensing	240hrs	※ TBD
	Thermal shock storage	-30°C ←→ 80°C (30min/30min)	100cycle	TBD
Mechanical test	Vibration test	Total amplitude 1.5mm, f = 10 ~55Hz, X,Y,Z directions for each 1 hours		TBD

Note: Ta = ambient temperature / Tp = Panel temperature

※ The profile of high temperature / humidity storage and High Temperature/humidity operation (Pure water of over 10MΩ·cm shall be used.)

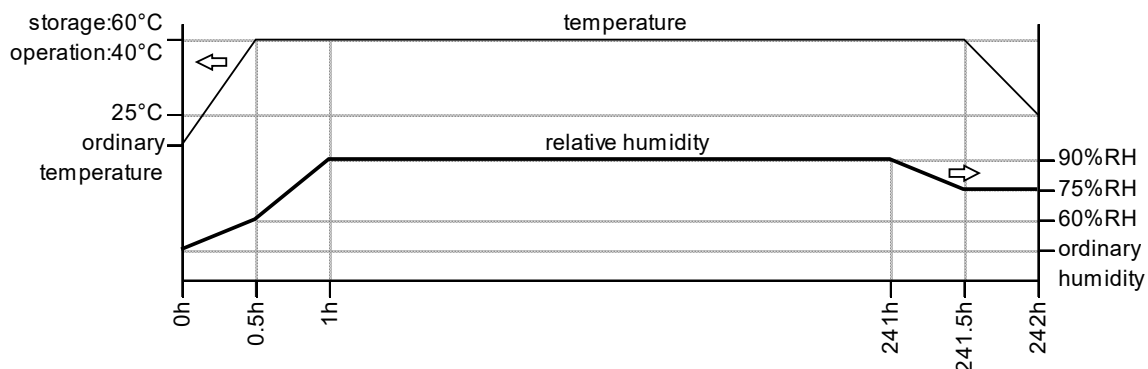

Reliability Criteria

Measure the parameters after leaving the monitor at the ordinary temperature for 24 hours or more after the test completion.

Item	Standard	Remark
Display quality	No visible abnormality shall be seen.	
Contrast ratio	(200) or more	Backlight ON



11. Packing Specifications

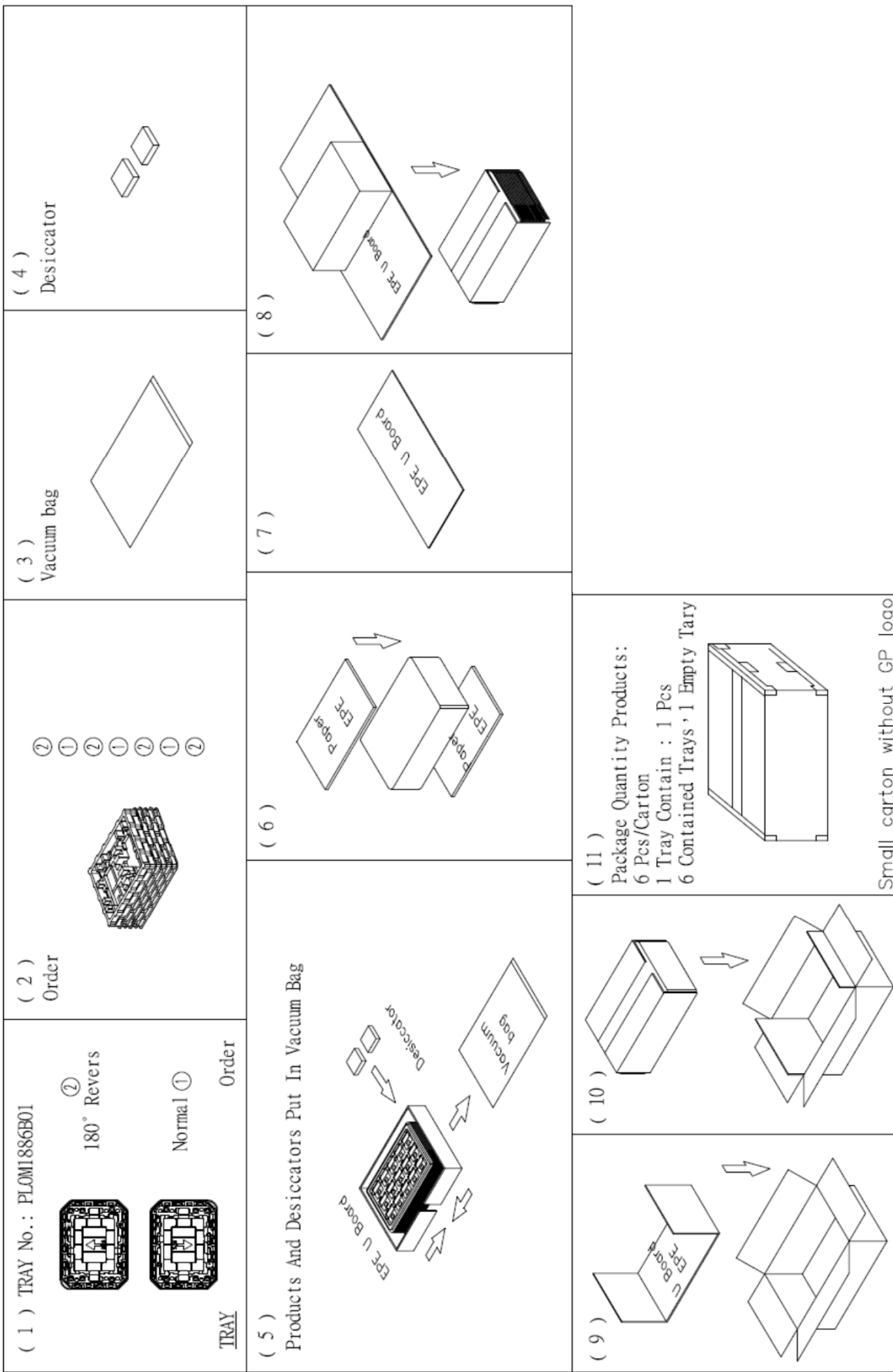

12. Handling Instruction

12.1 Cautions for Handling LCD panels



Caution

- (1) Do not make an impact on the LCD panel glass because it may break and you may get injured from it.
 - (2) If the glass breaks, do not touch it with bare hands.
(Fragment of broken glass may stick you or you cut yourself on it.)
 - (3) If you get injured, receive adequate first aid and consult a medial doctor.
 - (4) Do not let liquid crystal get into your mouth.
(If the LCD panel glass breaks, try not let liquid crystal get into your mouth even toxic property of liquid crystal has not been confirmed.)
 - (5) If liquid crystal adheres, rinse it out thoroughly.
(If liquid crystal adheres to your cloth or skin, wipe it off with rubbing alcohol or wash it thoroughly with soap.
If liquid crystal gets into eyes, rinse it with clean water for at least 15 minutes and consult an eye doctor.
- If you scrap this products, follow a disposal standard of industrial waste
- (6) that is legally valid in the community, country or territory where you reside.
 - (7) Do not connect or disconnect this product while its application products is powered on.
 - (8) Do not attempt to disassemble or modify this product as it is precision component.
 - (9) If a part of soldering part has been exposed, and avoid contact (short-circuit) with a metallic part of the case etc. about Circuit board of this model, please.
Please insulate it with the insulating tape etc. if necessary.
The defective operation is caused, and there is a possibility to generation of heat and the ignition.
 - (10) For protection your circuit, we recommend you to add excess current protection circuit to power supply.



Caution

This mark is used to indicate a precaution or an instruction which, if not correctly observed, may result in bodily injury, or material damages alone.

12.2 Precautions for Handling

- 1) Wear finger tips at incoming inspection and for handling the TFT monitors to keep display quality and keep the working area clean.
Do not touch the surface of the monitor as it is easily scratched.
- 2) Wear grounded wrist-straps and use electrostatic neutralization blowers to prevent static charge and discharge when handling the TFT monitors as the LED in this TFT monitors is damageable to electrostatic discharge.
Designate an appropriate operating area, and set equipment, tools, and machines properly when handling this product.
- 3) Avoid strong mechanical shock including knocking, hitting or dropping to the TFT monitors for protecting their glass parts.
Do not use the TFT monitors that have been experienced dropping or strong mechanical shock.
- 4) Do not use or storage the TFT monitors at high temperature and high humidity environment.
Particularly, never use or storage the TFT monitors at a location where condensation builds up.
- 5) Avoid using and storing TFT monitors at a location where they are exposed to direct sunlight or ultraviolet rays to prevent the LCD panels from deterioration by ultraviolet rays.
- 6) Do not stain or damage the contacts of the Connector
FPC cable needs to be inserted until it can reach to the end of connector slot.
During insertion, make sure to keep the cable in a horizontal position to avoid an oblique insertion.
Otherwise, it may cause poor contact or deteriorate reliability of the Connector.
- 7) Peel off the protective film on the TFT monitors during mounting process.
Refer to the section 12.5 on how to peel off the protective film.
We are not responsible for electrostatic discharge failures or other defects occur when peeling off the protective film.

12.3 Precautions for Operation

- 1) Since this TFT monitors are not equipped with light shielding for the driver IC,
do not expose the driver IC to strong lights during operation as it may cause functional failures.
- 2) In case of powering up or powering off this LCD module,
be sure to comply the sequence as instructed in this specification.
- 3) Do not plug in or out the FPC cable while power supply is switch on.
Plug the FPC cable in and out while power supply is switched off.
- 4) Do not operate the TFT monitors in the strong magnetic field. It may break the TFT monitors.
- 5) Do not display a fixed image on the screen for a long time.
Use a screen-saver or other measures to avoid a fixed image displayed on the screen for a long time.
Otherwise, it may cause burn-in image on the screen due the characteristics of liquid crystal.

12.4 Storage Condition for Shipping Cartons

(Storage environment)

- Temperature 0 to 40° C
- Humidity 60%RH or less
No-condensing occurs under low temperature with high humidity condition.
- Atmosphere No poisonous gas that can erode electronic components and/or wiring materials should be detected.
- Time period 1 year
- Unpacking To prevent damages caused by static electricity, anti-static precautionary measures (e.g. earthing, anti-static mat) should be implemented.
After unpack, keep product in the appropriate condition, otherwise bubble seal of Protective film may be printed on Polarizer.
- Maximum piling up (TBD) cartons

*Conditions to storage after unpacking

(Storage environment)

- Temperature 0 to 40° C
- Humidity 60%RH or less
No-condensing occurs under low temperature with high humidity condition.
- Atmosphere No poisonous gas that can erode electronic components and/or wiring materials should be detected.
- Time period 1 year (Shelf life)
- Others Keep/ store away from direct sunlight
Storage goods on original tray made by TOPPAN.

12.5 Precautions for Peeling off the Protective film

The followings work environment and work method are recommended to prevent the TFT monitors from static damage or adhesion of dust when peeling off the protective films.

A) Work Environment

- a) Humidity: 50 to 70 %RH, Temperature 15 to 27 ° C
- b) Operators should wear conductive shoes, conductive clothes, conductive finger tips and grounded wrist-straps.
Use an electrostatic neutralization blower.
- c) Anti-static treatment should be implemented to work area's floor.
Use a room shielded against outside dust with sticky floor mat laid at the entrance to eliminate dirt.

B) Work Method

TBD

12.6 Warranty

TOPPAN is only liable to defective goods which is stored and used under the condition complying with this specifications and returned within 1 (one) year.

Warranty caused by manufacturing defect shall be conducted by replacement of goods or refundment at unit price.

APPENDIX

Reference Method for Measuring Optical Characteristics and Performance

1.Measurement Condition (Backlight ON)

Measuring instruments: CS2000 (KONICA MINOLTA), LCD7200 (OTSUKA ELECTRONICS), EZcontrastXL88 (ELDIM)

Driving condition: Refer to the section "Optical Characteristics"

Measured temperature: 25°C unless specified

Measurement system: See the chart below. The luminance meter is placed on the normal line of measurement system.

Measurement point: At the center of the screen unless otherwise specified

Dark box at constant temperature

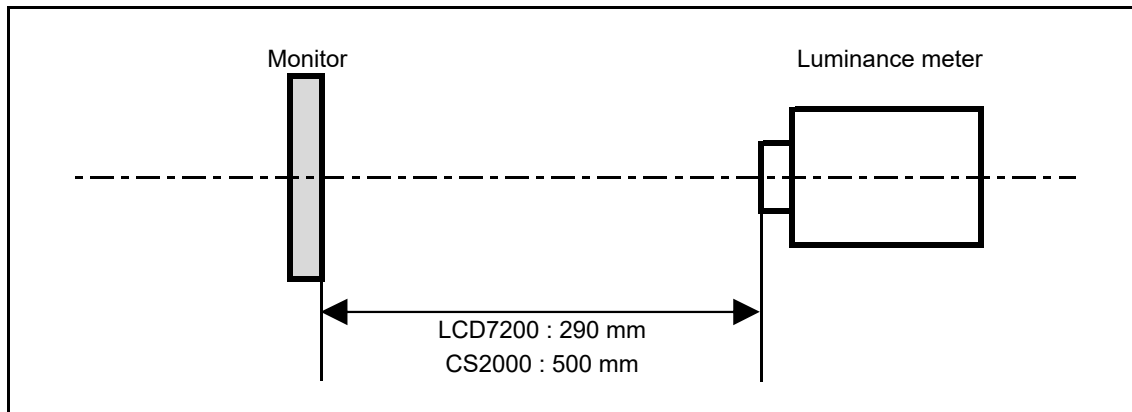

*Measurement is made after 30 minutes of lighting of the backlight.

Measurement point: At the center point of the screen

Brightness distribution: 9 points shown in the following drawing.

<Landscape model>

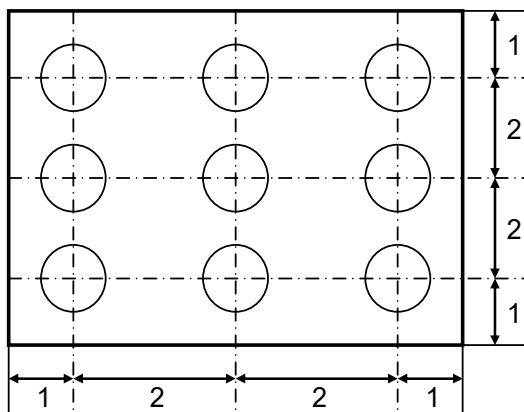

Dimensional ratio of active area



Backlight VL=12.0V, (IL=(45.0)mA)

Measurement Condition (Contrast ratio Backlight OFF only)

Measuring instruments: LCD7200(OTSUKA ELECTRONICS) , Ring Light (40,000 lx, $\phi 58$)

Driving condition: Refer to the section "Optical Characteristics"

Measured temperature: 25°C unless specified

Measurement system: See the chart below.

Measurement point: At the center of the screen unless otherwise specified

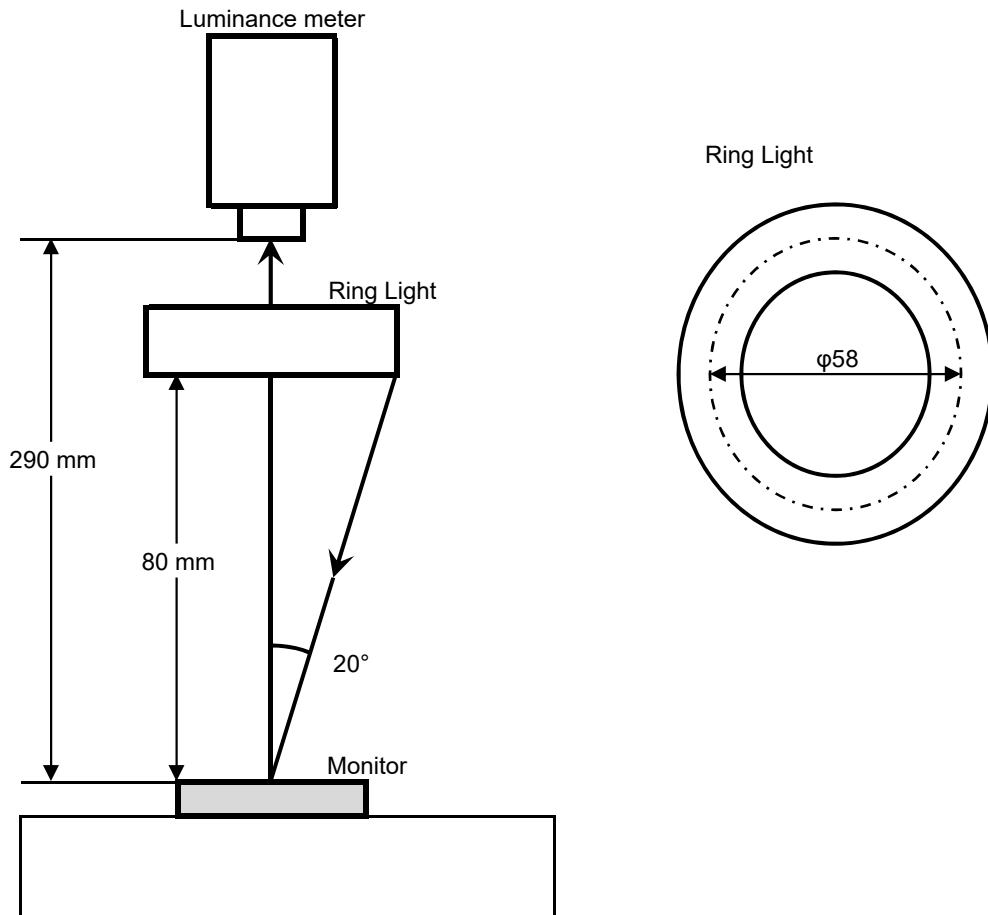

2. Test Method

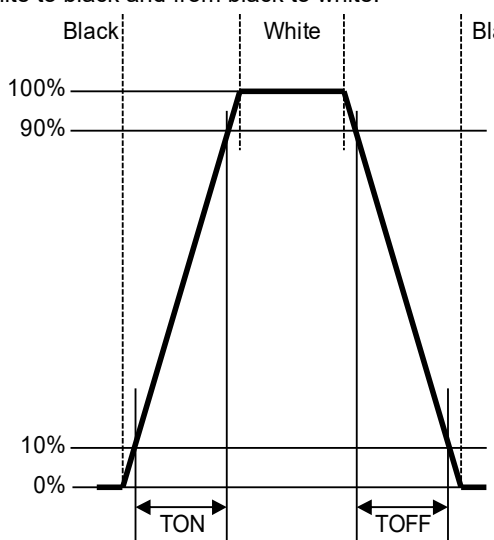
Notice	Item	Test method	Measuring instrument	Remark
1	Response time	<p>Measure output signal waveform by the luminance meter when raster of window pattern is changed from white to black and from black to white.</p> 	LCD7200	Black display [Data]=00h White display [Data]=FFh TON Rise time TOFF Fall time
2	Contrast ratio	<p>Measure maximum luminance Y1([Data]=(FF)h) and minimum luminance Y2([Data]=00h) at the center of the screen by displaying raster or window pattern. Then calculate the ratio between these two values.</p> <p>Contrast ratio = $Y1/Y2$</p> <p>Diameter of measuring point: 7.8mmφ(CS2000) Diameter of measuring point: 3mmφ(LCD7200)</p>	CS2000 LCD7200	Backlight ON Backlight OFF
3	Viewing angle Horizontalθ Verticalφ	Move the luminance meter from right to left and up and down and determine the angles where contrast ratio is 10.	EZcontrastXL88	
4	White chromaticity	<p>Measure chromaticity coordinates x and y of CIE1931 colorimetric system at [Data] =FFh</p> <p>Color matching function: 2°view measurement angle: 1°</p>	CS2000	
5	Center brightness	Measure the brightness at the center of the screen.	CS2000	
6	Brightness distribution	<p>(Brightness distribution) = $100 \times B/A \%$</p> <p>A : max. brightness of the 9 points B : min. brightness of the 9 points</p>	CS2000	