

Specifications for
Blanview TFT-LCD Monitor
(5.0" WVGA 800 x RGB x 480 Landscape)

Version 1.0

(Please be sure to check the specifications latest version.)

MODEL COM50H5N25ULC

Customer's Approval

Signature :

Name :

Section :

Title :

Date :

ORTUSTECH



TOPPAN INC.
Electronics Division
Technological Development Department III

Approved by

S. Epuchi

Checked by

J. Matsuzaki

Prepared by

M. Tojo

Version History

Ver.	Date	Page	Description
0.0	Dec.8,2022	-	- Tentative issue
1.0	Jun.29,2023	-	- First issue
△ ×6		P.1	Cover
		Change	Department name
		P.11	5. Absolute Maximum Rating
		Add	Conditioni
			6. Recommended Operating Conditions
		Correct	Operating humidity range
		P.19	9.1 Optical Characteristics
		Change	Reference brightness
		Add	White Chromaticity
		P.21	10.1 Defective Display and Screen Quality
Add	Signal condition		
P.23	11. Reliability Test		
Add	number of failures / number of examinations		
Add	Applied voltage (Surface discharge test)		
Correct	Error correct		

1. Application

This Specification is applicable to 127.35 mm (5.0 inch) Blanview TFT-LCD monitor for non-military use.

- ◎ TOPPAN makes no warranty or assume no liability that use of this Product and/or any information including drawings in this Specification by Purchaser is not infringing any patent or other intellectual property rights owned by third parties, and TOPPAN shall not grant to Purchaser any right to use any patent or other intellectual property rights owned by third parties. Since this Specification contains TOPPAN's confidential information and copy right, Purchaser shall use them with high degree of care to prevent any unauthorized use, disclosure, duplication, publication or dissemination of TOPPAN's confidential information and copy right.
- ◎ If Purchaser intends to use this Products for an application which requires higher level of reliability and/or safety in functionality and/or accuracy such as transport equipment (aircraft, train, automobile, etc.), disaster-prevention/security equipment or various safety equipment, Purchaser shall consult TOPPAN on such use in advance.
- ◎ This Product shall not be used for application which requires extremely higher level of reliability and/or safety such as aerospace equipment, telecommunication equipment for trunk lines, control equipment for nuclear facilities or life-support medical equipment.
- ◎ It must be noted as an mechanical design manner, especial attention in housing design to prevent arcuation/flexure caused by stress to the LCD module shall be considered.
- ◎ TOPPAN assumes no liability for any damage resulting from misuse, abuse, and/or miss-operation of the Product deviating from the operating conditions and precautions described in the Specification.
- ◎ It shall be mutually conferred if nonconforming defect which result from unspecified cause in this specification arises.
- ◎ If any issue arises as to information provided in this Specification or any other information, TOPPAN and Purchaser shall discuss them in good faith and seek solution.
- ◎ TOPPAN assumes no liability for defects such as electrostatic discharge failure occurred during peeling off the protective film or Purchaser's assembly process.
- ◎ This Product is compatible for RoHS(2.0) directive.

Object substance	Maximum content [ppm]
Cadmium and its compound	100
Hexavalent Chromium Compound	1000
Lead & Lead compound	1000
Mercury & Mercury compound	1000
Polybrominated biphenyl series (PBB series)	1000
Polybrominated biphenyl ether series (PBDE series)	1000
Bis(2-ethylhexyl)phthalate series(DEHP series)	1000
Butyl benzyl phthalate series(BBP series)	1000
Dibutyl phthalate series(DBP series)	1000
Diisobutyl phthalate series(DIBP series)	1000

2. Outline Specifications

2.1 Features of the Product

- 5.0 inch diagonal display, 800 x RGB [H] x 480 [V] dots.
- 16.7 M colors (8-bit) / 262 k colors (6-bit).
- 3.3V voltage single power source.
- Timing generator [TG], Counter-electrode driving circuitry, Built-in power supply circuit.
- Long life & High bright white LED back-light.
- Blanview TFT-LCD, improved outdoor readability.

	Indoor		Outdoor	
	Readability	Power Efficiency (Battery Life)	Readability	Power Efficiency (Battery Life)
Transmissive	Good	Good	Fair	Poor
Transflective	Fair	Poor	Good	Good
Blanview	Good	Good	Good	Good

2.2 Display Method

Items	Specifications	Remarks
Display type	16.7 M colors. / 262 k colors. Blanview, Normally black.	
Driving method	a-Si TFT Active matrix. Line-scanning, Non-interlace.	
Dot arrangement	RGB stripe arrangement.	Refer to "Dot arrangement"
Signal input method	8-bit / 6-bit LVDS interface (VESA format)	
Backlight type	Long life & High bright white LED.	
NTSC ratio	50 %	

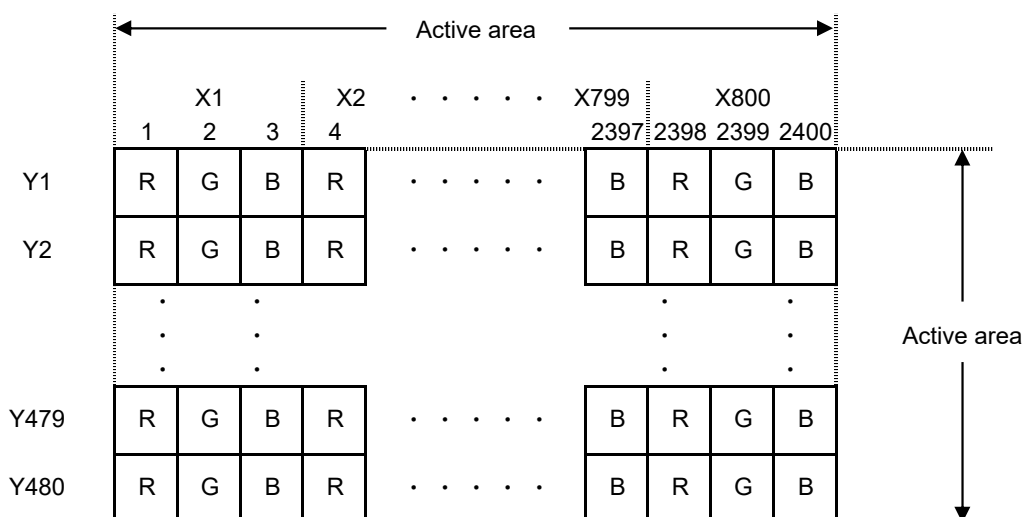

Dot arrangement (FPC cable placed down side)

<Features of Blanview>

- Backlight power consumption required to assure visibility. (equivalent to 3.5"QVGA)

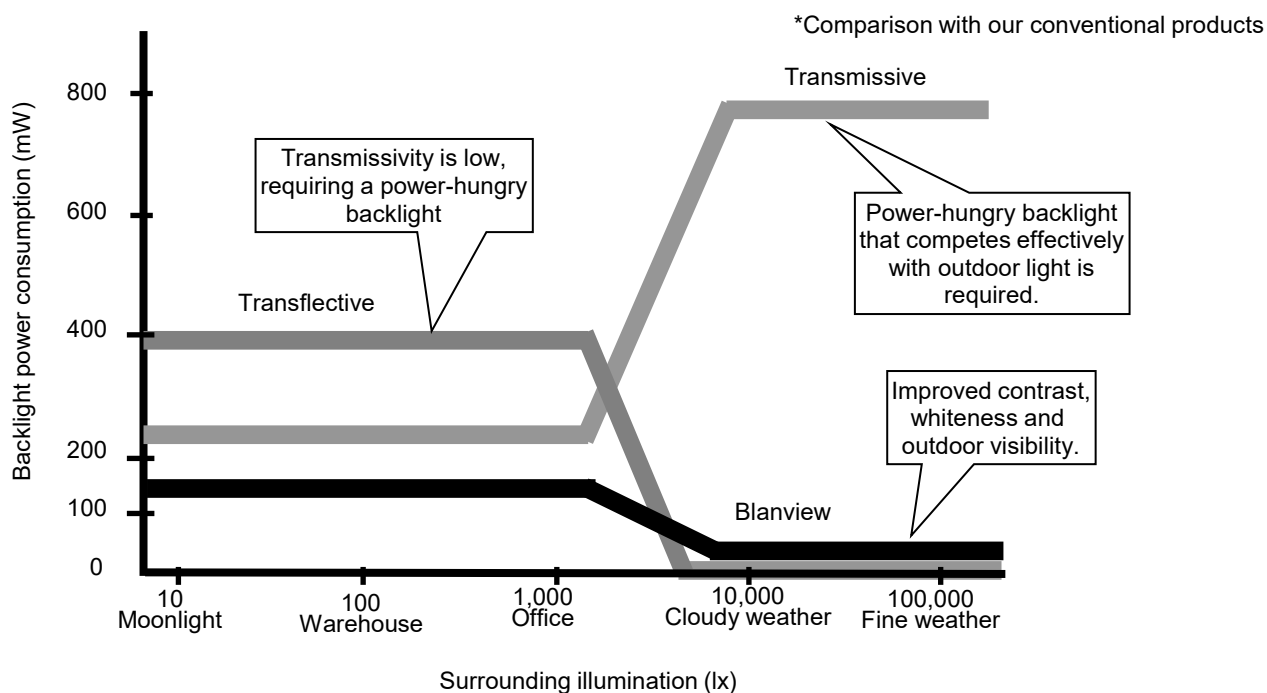

- Contrast characteristics under 100,000lx. (same condition as direct sunlight.)

With better contrast (higher contrast ratio), Blanview TFT-LCD has the best outdoor readability in three different types of TFT-LCD.

Below chart shows contrast value against panel surface brightness. (Horizontal: Panel surface brightness/ Vertical: Contrast value) LCD panel has enough outdoor readability above our Standard line. (TOPPAN criteria)

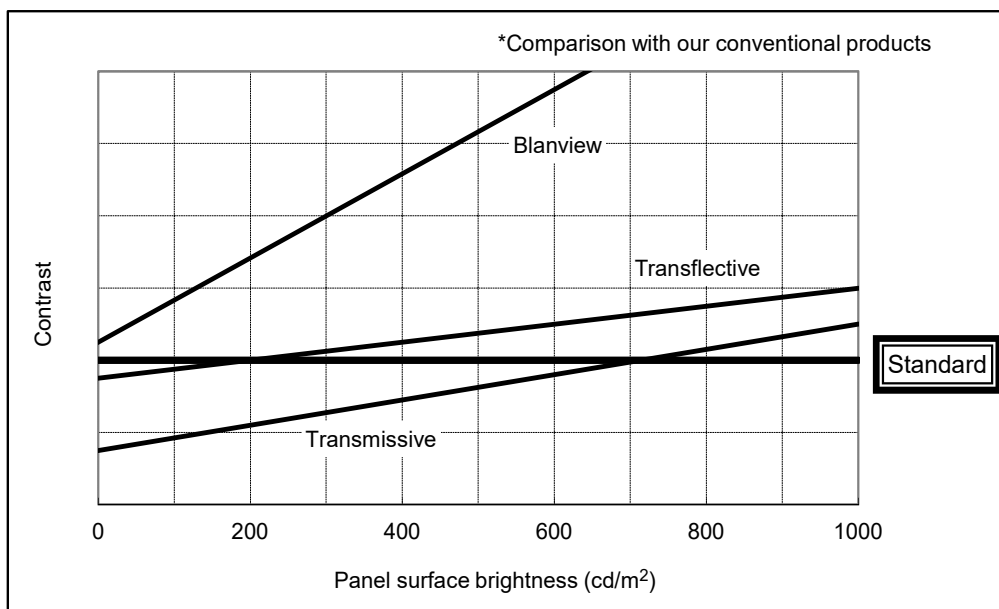

3. Dimensions and Shape

3.1 Dimensions

Items	Specifications	Unit	Remarks
Outline dimensions	124.00[H] × 80.82[V] × 6.18[D]	mm	Exclude FPC cable and parts on FPC.
Active area	109.20[H] × 65.52[V]	mm	127.35mm diagonal
Number of dots	2400[H] × 480[V]	dot	
Dot pitch	45.5[H] × 136.5[V]	um	
Surface hardness of the polarizer	2	H	2.94N
Weight	88	g	Include FPC cable

3.2 Outward Form

EC No.	REV. No.	REVISE	DATE (Y:M:D)	APPROVED	CHECKED	PREPARED
####			##:##:##	##	##	

(8/32)
22TLM113
Issue: Jun.29,2023

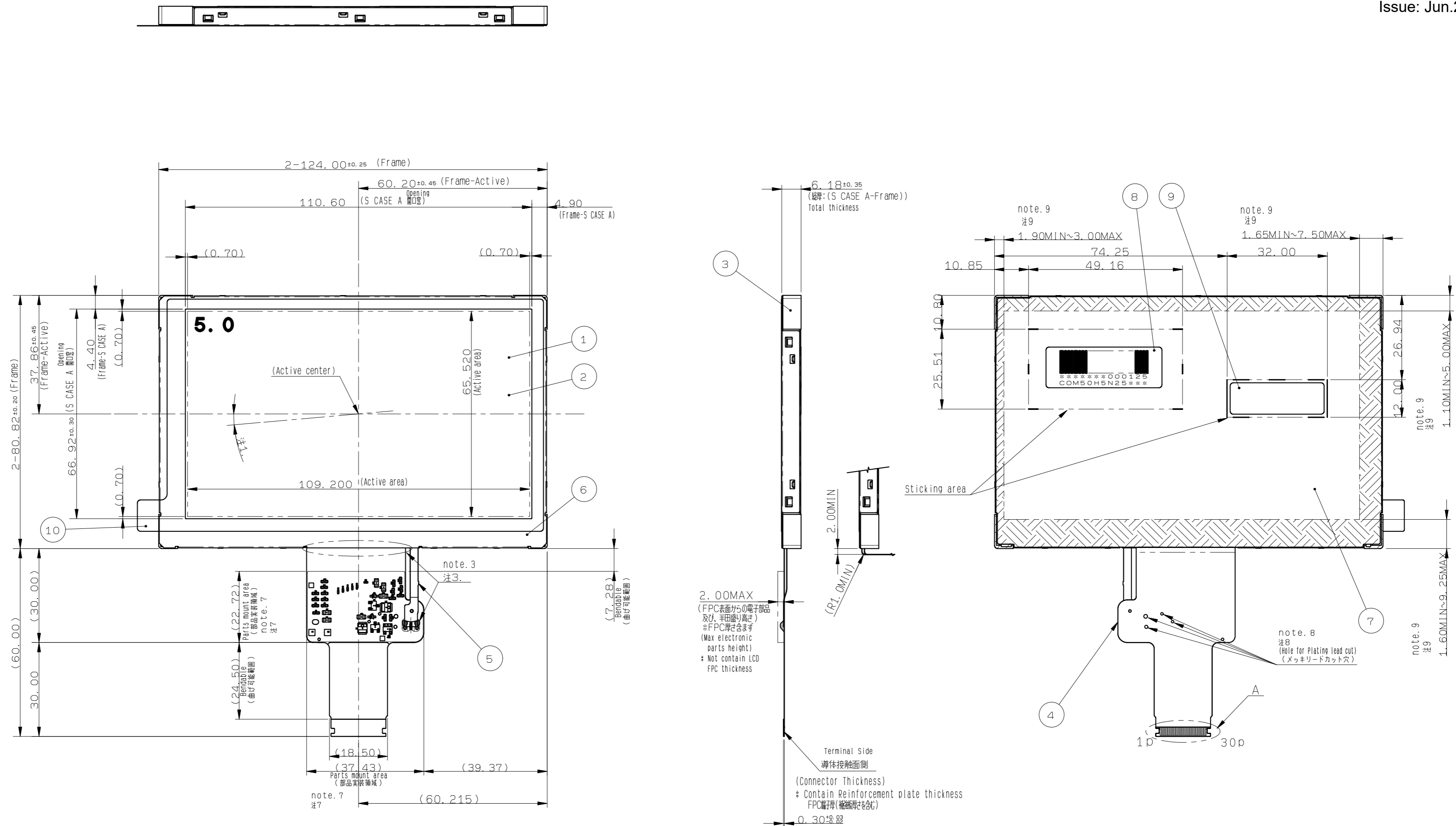

Angular deviation of LCD cell from the TFT-LCD monitor's reference note axis shall be less than $\pm 50'$.
注1. TFT-LCD PANELの角度ズレは、モニター基準軸に対し $\pm 50'$ 以下とする。
Protective film is affixed on front surface of the screen.
Protective film is not protrude from the outline of the monitor.
2. 保護膜が表面側に貼られる。
保護膜はモニター外形からはみ出さないものとする。
Don't stress to FPC bonding area & the solder area.
3. FPCの圧着部及び半田接続部には負荷の掛からないようご注意ください。
Recommended FPC connectors : IRI50/IMS A-9699S-30A-GFN1(Lower contact)
4. FPCの推奨コネクタの規格を下記に示す。
イリソ電子工業 : 9699 series (IMS A-9699S-30A-GFN1(下接点))
A SERIAL LABEL is affixed the area as shown in the drawing.
The thickness of SERIAL LABEL will be added to that of part's(S CASE C's) surface.
5. SERIAL LABELが図示の位置に貼り付けられます。
シラベル厚さが貼付け面から(S CASE Cから)凸となります。

Burrs direction of S CASE is outward.(Burrs size is less than 0.03mm.)
6. S CASEのバリ方向は外側になります。(MAXO.03mm)
Don't touch any conductive material to conductive area.
7. 導体開口部は導体部品との接触を避けてください。
Don't touch any conductive material to plating cut area.
8. メッキリードカット位置は導体部品との接触を避けてください。
In case TFT-LCD monitor is fixed to the case of your product. It's recommended that monitor is fixed in to area.
9. モニタは 範囲内で固定することを推奨いたします。

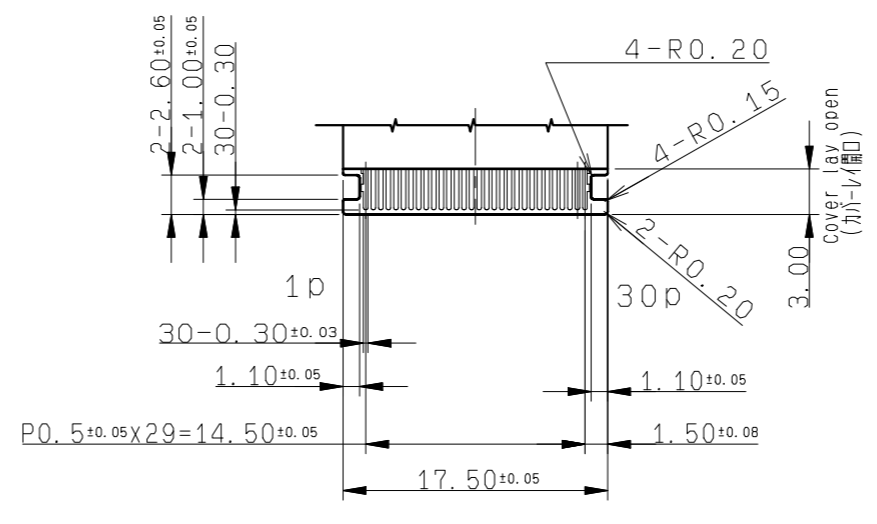

PART NAME	ITEM	PART CODE	MODEL NUMBER	REMARK
Protective film	10			
LABEL	9			For BL unit (30x10x0.080t)
S LABEL	8	Barcode(CODE39)		For Monitor (37x13x0.075t)
S CASE C	7			SUS (t=0.20)
S CASE A	6			SUS (t=0.15)
FPC B	5			Use of LED
FPC A	4			Au/Ni plating AU/Niメッキ Use of LCD
Frame	3			PC
Polarizer	2			
TFT-LCD PANEL	1			Glass thickness=0.50±0.50t

APPROVED	木下大輔	GENERAL TOLERANCE ±0.5	SCALE 1/1	UNIT mm
CHECKED	加藤真一	ISSUE (Y:M:D) 23:06:12	MODEL CCM50H5N25U**	 TOPPAN INC. DO NOT DUPLICATE, CONFIDENTIAL AND PROPRIETARY
CHECKED		NAME		
DESIGN	雷田恵太	OUTLINE-D5N25		DRAWING No. RJD603544D201
DRAW	雷田恵太			REV. SHEET DIV. # /

3.3 Serial Label (S-label)

3.3.1 Display Items

A section : Bar code

B section : Combination of a character

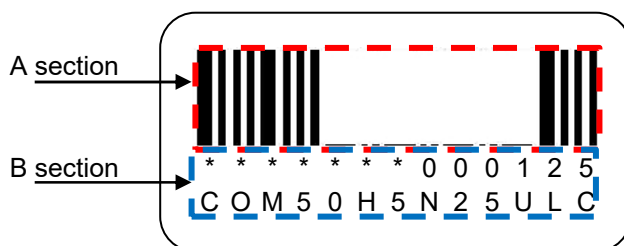

Details of B section

Upper column: It indicates The least significant digit of manufacture year (1 digit), manufacture month with below alphabet (1letter), model code (5characters), serial number (6digits).

* * ***** *****
 — — — —
 a b c d

Contents of display							
a	The least significant digit of manufacture year						
b	Manufacture month	Jan-A	Mar-C	May-E	Jul-G	Sep-I	Nov-K
		Feb-B	Apr-D	Jun-F	Aug-H	Oct-J	Dec-L
c	Model code	50CZC (Made in Japan) 50DAC (Made in Malaysia)					
d	Serial number						

* Example of indication of Serial label (S-label)

•Made in Japan

3L50CZC000125

means "manufactured in December 2023, 5.0" CZ type, C specifications, serial number 000125"

•Made in Malaysia

3L50DAC000125

means "manufactured in December 2023, 5.0" DA type, C specifications, serial number 000125"

Lower column: Model (13characters)

3.3.2 Location of Serial Label (S-label)

Refer to 3.2 "Outward Form".

3.3.3 Others

Bar code readability is excluded from quality assurance coverage.

4. Pin Assignment

No.	Symbol	Function
1	BLH	LED drive power source. (Anode side)
2	BLL2	LED drive power source . (Cathode side 2)
3	BLL1	LED drive power source . (Cathode side 1)
4	GND	Ground
5	VDD	Power supply input.
6	VDD	Power supply input.
7	TEST1	TEST input (Connect to VDD)
8	TEST2	TEST input (Connect to GND)
9	TEST3	TEST input (Connect to GND)
10	NC	No connection
11	UL/DR	Up & Left / Down & Right switching terminal (Low : DR , High or NC : UL)
12	IM	6 / 8 bit (based on VESA) switching terminal (Low : 6bit , High or NC : 8bit)
13	STBYB	Standby signal (Low: Standby operation,High:Normal operation)
14	GND	Ground
15	R0-	LVDS DATA0(-)
16	R0+	LVDS DATA0(+)
17	GND	Ground
18	R1-	LVDS DATA1(-)
19	R1+	LVDS DATA1(+)
20	GND	Ground
21	CLK-	LVDS CLK(-)
22	CLK+	LVDS CLK(+)
23	GND	Ground
24	R2-	LVDS DATA2(-)
25	R2+	LVDS DATA2(+)
26	GND	Ground
27	R3-	LVDS DATA3(-)
28	R3+	LVDS DATA3(+)
29	GND	Ground
30	NC	No connection

- Recommended connector : IRISO ELECTRONICS 9699 series [IMSA-9699S-30A-GFN1]
- Please make sure to check a consistency between pin assignment in "3.2 Outward Form" and your connector pin assignment when designing your circuit.
Inconsistency in input signal assignment may cause a malfunction.
- Since FPC cable has gold plated terminals, gilt finish contact shoe connector is recommended.



5. Absolute Maximum Rating

GND=0V

Item	Symbol	Condition	Rating		Unit	Applicable terminal
			MIN	MAX		
Supply voltage	VDD		-0.3	3.9	V	VDD
Input voltage for logic	VI		-0.3	VDD+0.3	V	UL/DR , IM , STBYB
Forward current	IL	Ta=25°C	--	70	mA	BLH-BLL1/BLL2
Storage temperature range	Tstg		-40	95	°C	
Storage humidity range	Hstg		Non condensing in an environmental moisture at or less than 40 °C90%RH.			



6. Recommended Operating Conditions

GND=0V

Item	Symbol	Condition	Rating			Unit	Applicable terminal
			MIN	TYP	MAX		
Supply voltage	VDD		3.0	3.3	3.6	V	VDD
Input voltage for logic	VI		0	--	VDD	V	UL/DR , IM , STBYB
Operational temperature range	Top	Note1	-30	+25	+85	°C	Panel surface temperature
Operating humidity range	Hop	Ta≤40°C	20	--	85	%	
		Ta>40°C	Non condensing in an environmental moisture at or less than 40 °C85%RH.				

Note1: This monitor is operable in this temperature range. With regard to optical characteristics, refer to Item 9."Characteristics".

7. Electrical Characteristics

7.1 DC Characteristics

(Unless otherwise noted, Ta=25 °C,VDD=3.3V,GND=0V)

Item	Symbol	Condition	Rating			Unit	Applicable terminal
			MIN	TYP	MAX		
High Level Input Voltage	VIH		0.7VDD	—	VDD	V	UL/DR, IM,STBYB
Low Level Input Voltage	VIL		0	—	0.3VDD	V	
Pull up resistor	RI		200	350	850	kΩ	Pull up : IM , STBYB
			100	175	425	kΩ	Pull up : UL/DR
Operating Current	IDD	Color Bar Input timing=typ	—	38	76	mA	VDD

(Backlight)

Item	Symbol	Condition	Rating			Unit	Applicable terminal
			MIN	TYP	MAX		
Forward current	IL	Ta=25 °C	--	20	70	mA	BLH - BLL1 / BLL2
Forward voltage	VL	Ta=25 °C IL=20.0 mA Note1	--	13.7	14.9	V	
Estimated Life of LED	LL	Ta=25 °C IL=20.0 mA Note2	--	100,000	--	hrs	

Note1: - Reference value

Note2: - The lifetime of the LED is defined as a period till the brightness of the LED decreases to the half of its initial value.

- This figure is given as a reference purpose only, and not as a guarantee.
 - This figure is estimated for an LED operating alone.
- As the performance of an LED may differ when assembled as a monitor.
- Estimated lifetime could vary on a different temperature and usually higher temperature could reduce the life significantly.

7.2 LVDS interface

7.2.1 LVDS DC Characteristics

(Unless otherwise noted, $T_a=25\text{ }^\circ\text{C}$, $V_{DD}=3.3\text{V}$, $GND=0\text{V}$)

Item	Symbol	Condition	Rating			Unit	Applicable terminal
			MIN	TYP	MAX		
Differential input high threshold voltage	Rxvth	$R_{XVCM}=1.2\text{V}$	-	-	0.1	V	CLK+, CLK-, R0+, R0-, R1+, R1-, R2+, R2-, R3+, R3-
Differential input low threshold voltage	Rxvtl		-0.1	-	-	V	
Differential input common Mode voltage	Rxvcm		1.0	1.2	$1.8- VID /2$	V	
Differential input voltage	$ V_{ID} $		0.2	-	0.6	V	
Differential input leakage current	$R_{V_{leak}}$		-10	-	+10	μA	

Single end signals

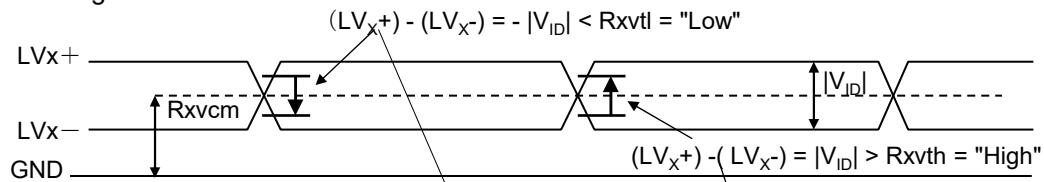

Differential signals

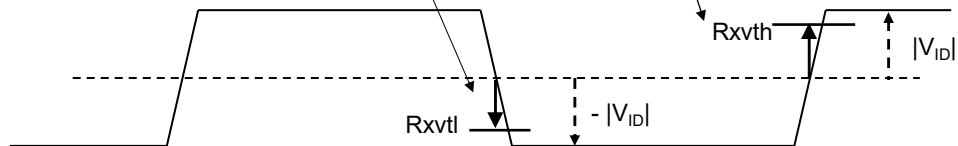

7.2.2 LVDS AC Characteristics

(Unless otherwise noted, $T_a=25\text{ }^\circ\text{C}$, $V_{DD}=3.3\text{V}$, $GND=0\text{V}$)

Item	Symbol	Rating			Unit	
		MIN	TYP	MAX		
CLK Frequency	f clk	25.2	27.2	30.5	MHz	
Clock period	Tc	32.8	36.8	39.7	ns	
1 data bit time	UI	-	1/7	-	Tc	
CLK High level Width	T chw	2.9	4	4.1	UI	
CLK Low level Width	T clw	2.9	3	4.1	UI	
Position 1	Tpos_1	-0.2	0	0.2	UI	
Position 0	Tpos_0	0.8	1	1.2	UI	
Position 6	Tpos_6	1.8	2	2.2	UI	
Position 5	Tpos_5	2.8	3	3.2	UI	
Position 4	Tpos_4	3.8	4	4.2	UI	
Position 3	Tpos_3	4.8	5	5.2	UI	
Position 2	Tpos_2	5.8	6	6.2	UI	
Receiver Strobe Position 7	TEYEW	0.6	-	-	UI	
Receiver Strobe Position 8	TEX	-	-	0.2	UI	

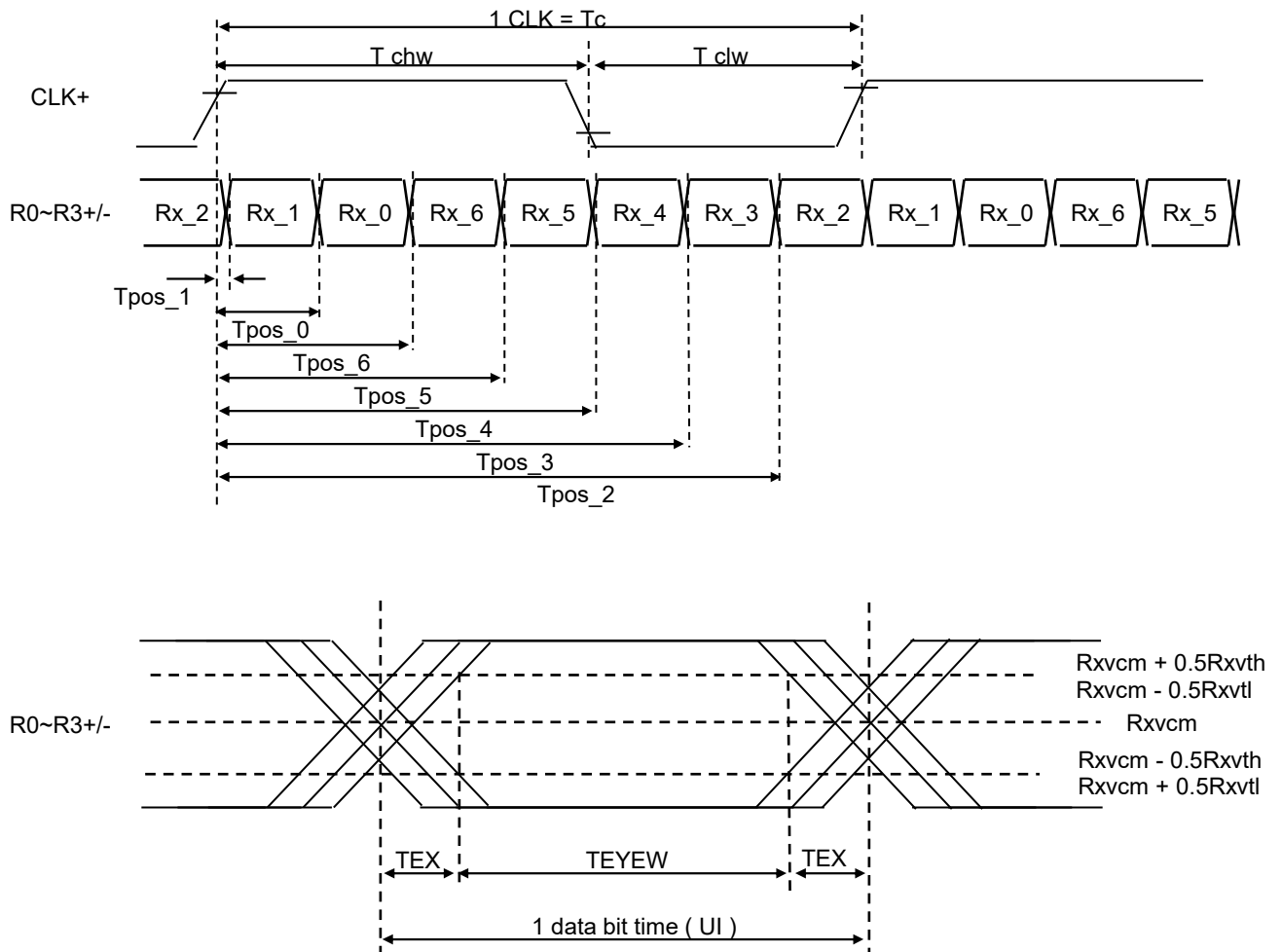

7.2.3 LVDS Data Format

VESA Format 8bit

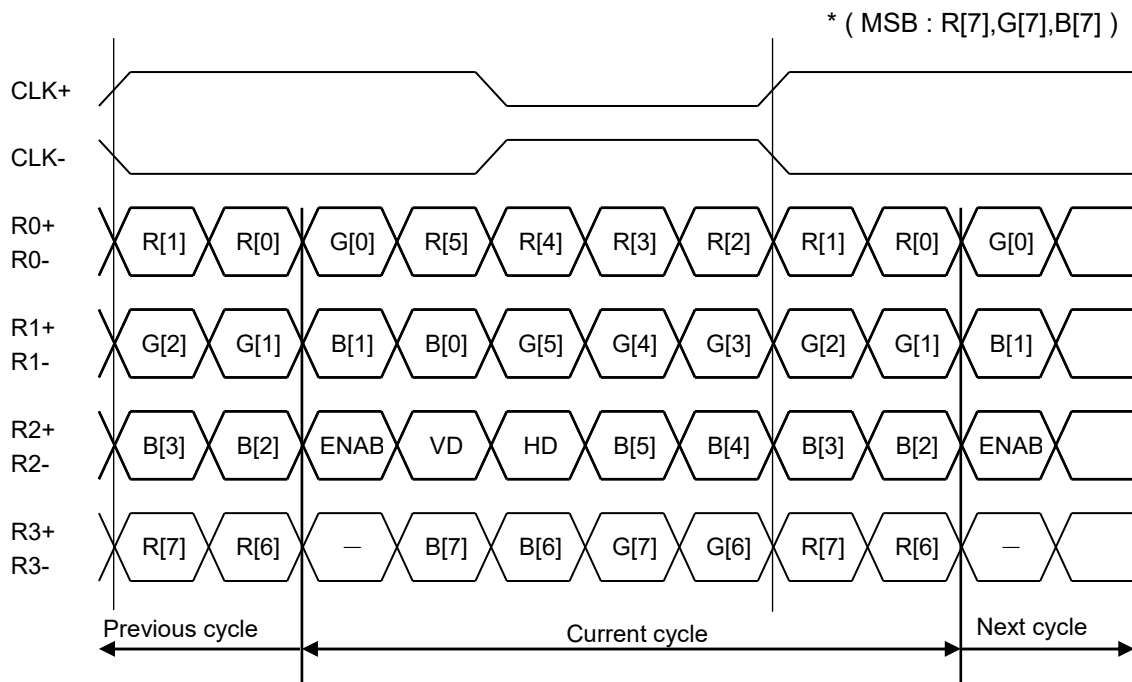

VESA Format 6bit

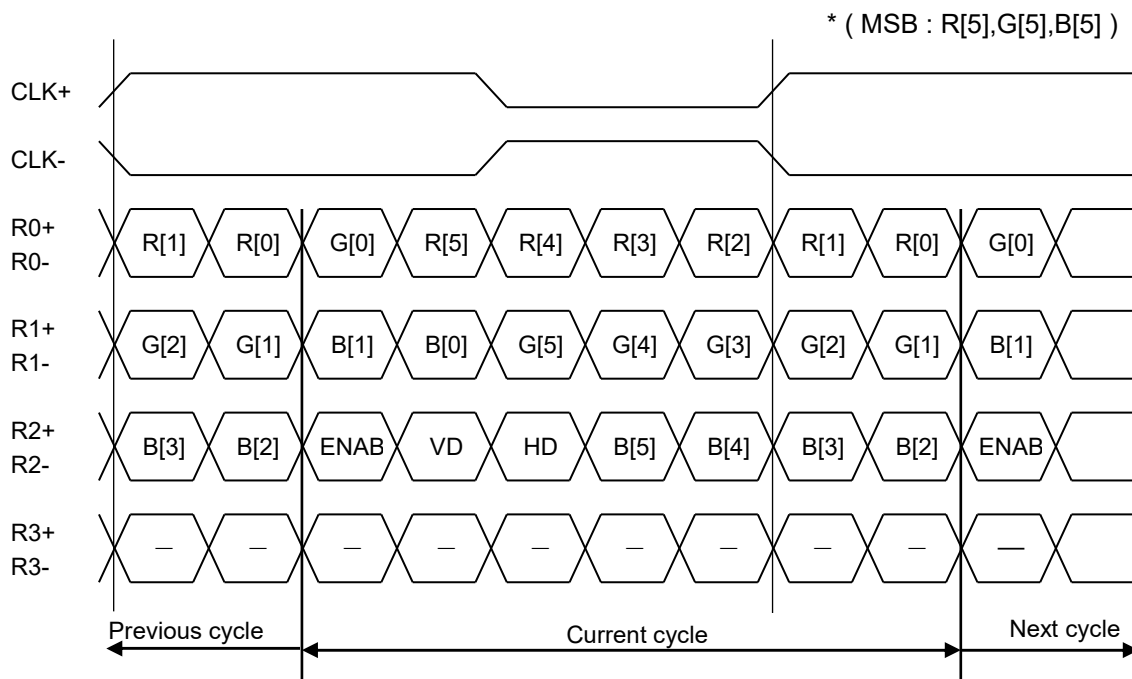

7.3 Input timing

Item	Symbol	Rating			Unit	Signal (*)
		MIN	TYP	MAX		
CLK frequency	fCLK	25.2	27.2	30.5	MHz	CLK
VD frequency	fVD	54	60	66	Hz	VD
1 vertical field	tv	490	528	552	H	
VD pulse width	tvp	1	2	66	H	
VD back porch	tvb	5	10	67	H	
VD front porch	tvf	5	38	67	H	
Vertical valid data	tvdp	480			H	VD,HD,ENAB R[7:0],G[7:0],B[7:0]
HD frequency	fHD	-	31.7	-	kHz	
1 horizontal field	th	856	860	920	CLK	
HD pulse width	thp	1	2	100	CLK	
HD back porch	thb	5	16	101	CLK	
HD front porch	thf	19	44	115	CLK	CLK,HD,ENAB R[7:0],G[7:0],B[7:0]
ENAB pulse width	tenp	800			CLK	
Horizontal valid data	thdp	800			CLK	

(*) Input terminals are (R0+/- , R1+/- , R2+/- , R3+/- , CLK+/-).

<Vertical timing>

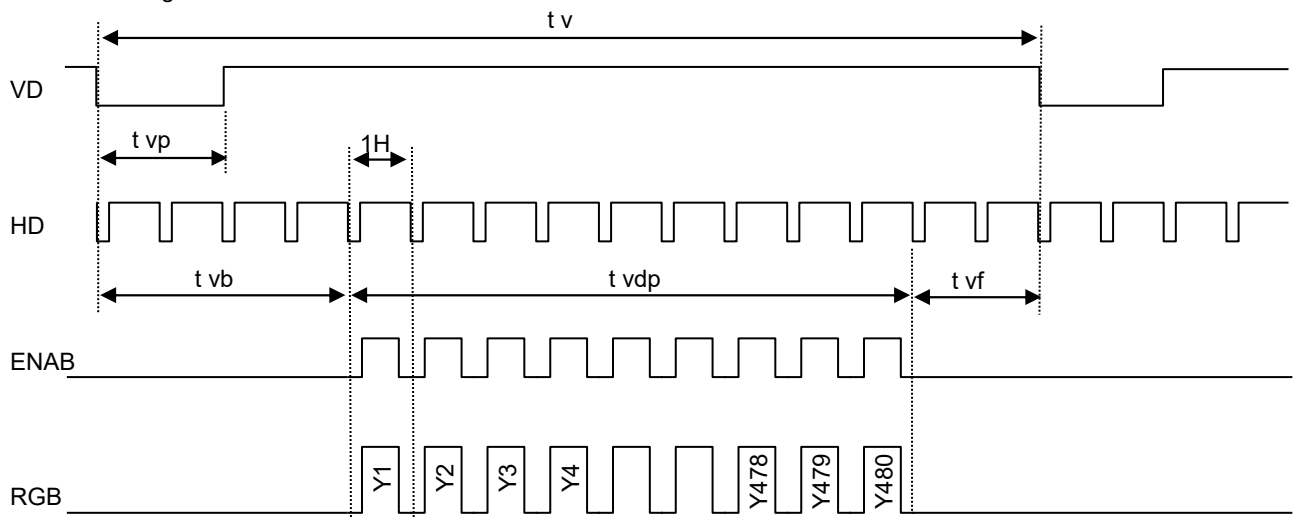

<Horizontal timing>

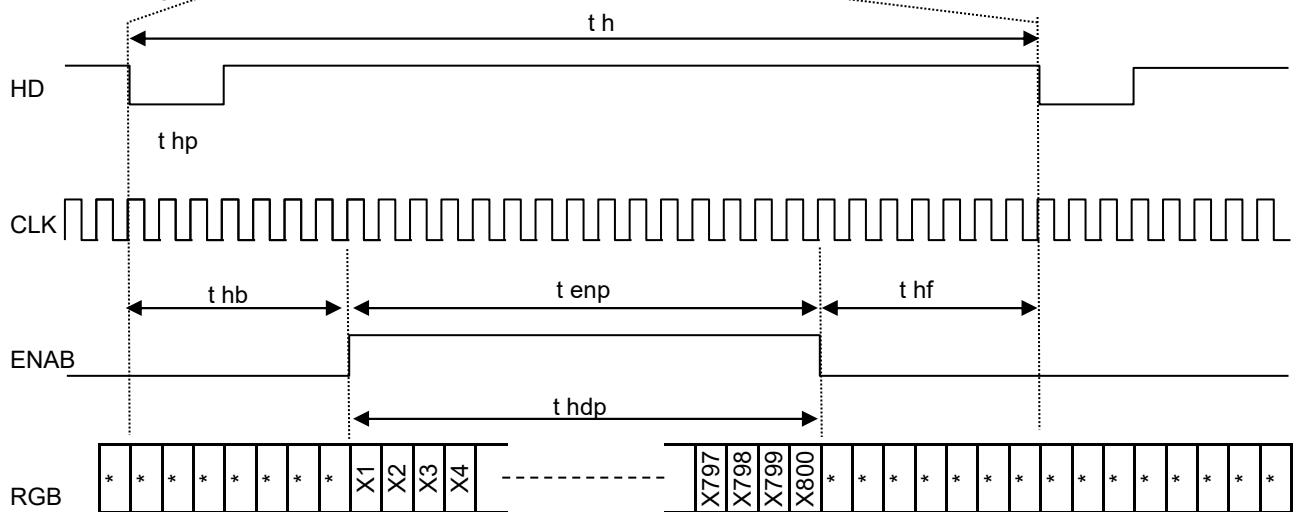

7.4 Power ON/OFF sequences

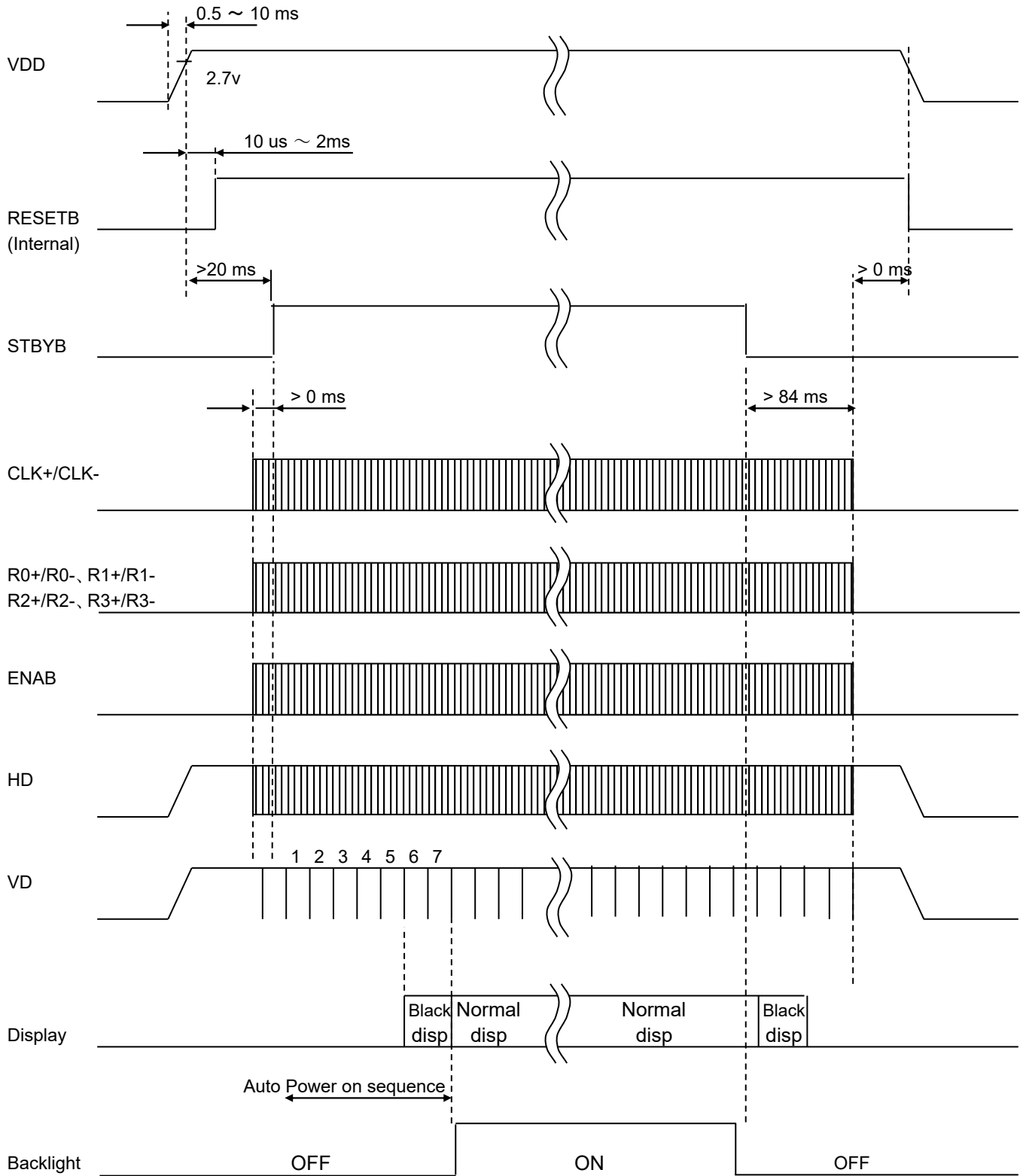

Note: ENAB, HD and VD are included in the R2 + / R2- terminals.

8. LED Circuit

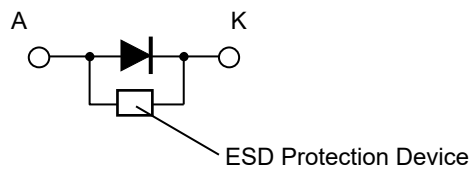
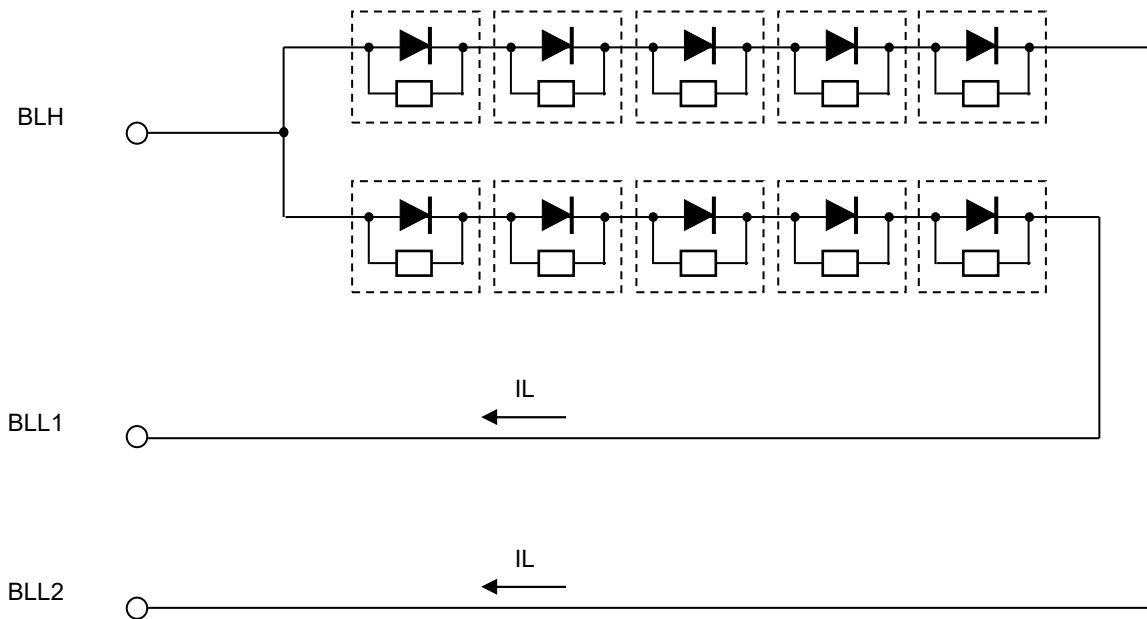

9. Characteristics

 9.1 Optical Characteristics

(Measurement Condition)

Measuring instruments: CS2000 (KONICA MINOLTA), LCD7200 (OTSUKA ELECTRONICS), EZcontrastXL88 (ELDIM)

Driving condition: VDD=3.3V, GND=0V, Optimized VCOMDC

Backlight: IL= 20.0 mA

Measured temperature: Ta = 25°C

Item		Symbol	Condition	MIN	TYP	MAX	Unit	Note №	Remark
Response time	Rise time	TON	[Data]= 00h← → FFh	-	-	50	ms	1	
	+ Fall time	TOFF							
Contrast ratio	Backlight ON	CR	[Data]= FFh / 00h	420	700	-		2	
	Backlight OFF			-	2.5	-			
Viewing angle	Left	θL	[Data]= FFh / 00h CR ≥ 10	80	-	-	deg	3	
	Right	θR		80	-	-	deg		
	Up	φU		80	-	-	deg		
	Down	φD		80	-	-	deg		
White Chromaticity		x y	[Data]= FFh	White chromaticity range				4	
Center Brightness			[Data]= FFh	- 240	1200 420	- -	cd/m ²	5	IL= 65.0 mA *reference only IL= 20.0 mA
Brightness distribution			[Data]= FFh	70	-	-	%	6	
Burn-in				No noticeable burn-in image shall be observed after 2 hours of window pattern display.				7	

* Note number 1 to 7: Refer to the APPENDIX of "Reference Method for Measuring Optical Characteristics and Performance".

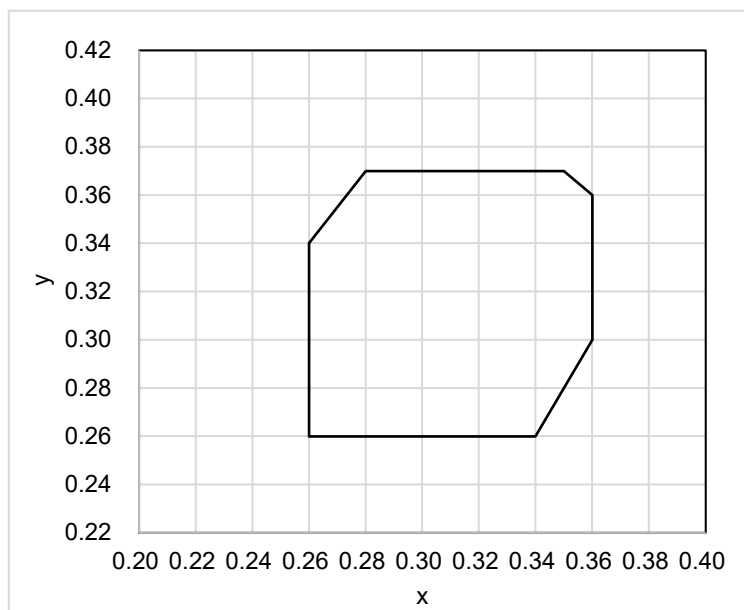

White Chromaticity Range

(White Chromaticity Range)

x	y
0.26	0.34
0.26	0.26
0.34	0.26
0.36	0.30
0.36	0.36
0.35	0.37
0.28	0.37

9.2 Temperature Characteristics

(Measurement Condition)

Measuring instruments: CS2000 (KONICA MINOLTA), LCD7200 (OTSUKA ELECTRONICS)

Driving condition: VDD=3.3V, GND=0V, Optimized VCOMDC

Backlight: IL= 20.0 mA

Item		Symbol	Specification		Remark
			Ta = -30 °C	Ta = 85 °C	
Response time	Rise time + Fall time	TON + TOFF	1500 msec or less	40 msec or less	
Contrast ratio		CR	200 or more	200 or more	Backlight ON
Display Quality			No noticeable display defect or ununiformity should be observed.		

10. Criteria of Judgment

△ 10.1 Defective Display and Screen Quality

Test Condition: Observed TFT-LCD monitor from front during operation with the following conditions

Driving Signal: Raster Patter (RGB, white, black)

Signal condition: [Data]:00h, 94h, FFh (3steps)

Observation distance: 30 cm

Illuminance: 200 to 350 lx

Backlight: IL=20.0mA

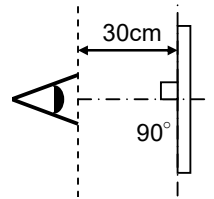

Defect item	Defect content	Criteria		
Display Quality	Line defect	Black, white or color line, 3 or more neighboring defective dots	Not exists	
	Dot defect	Uneven brightness on dot-by-dot base due to defective TFT or CF, or dust is counted as dot defect (brighter dot, darker dot)	Refer to table 1	
		High bright dot: Visible through 2% ND filter at [Data]=00h	Acceptable	
		Low bright dot: Visible through 5% ND filter at [Data]=00h Dark dot: Appear dark through white display at [Data]=94h Invisible through 5% ND filter at [Data]=00h		
Stain	Uneven brightness (white stain, black stain etc)	Invisible through 5% ND filter at Black screen. Invisible through 1% ND filter at other screen.		
Screen Quality	Foreign particle	Point-like	$0.25\text{mm} < \varphi$	N=0
			$0.20\text{mm} < \varphi \leq 0.25\text{mm}$	$N \leq 2$
			$\varphi \leq 0.20\text{mm}$	Acceptable
	Liner	$3.0\text{mm} < \text{length and } 0.08\text{mm} < \text{width}$	N=0	
		$\text{length} \leq 3.0\text{mm or width} \leq 0.08\text{mm}$	Acceptable	
Others		Use boundary sample for judgment when necessary		

φ (mm): Average diameter = (major axis + minor axis)/2
Permissible number: N

Table1

Area	High bright dot	Low bright dot	Dark dot	Total	Criteria
A	0	2	2	3	Permissible distance between same color bright dots (includes neighboring dots): 3 mm or more Permissible distance between same color high bright dots (includes neighboring dots): 5 mm or more
B	2	4	4	6	
Total	2	4	4	7	

<Landscape model>

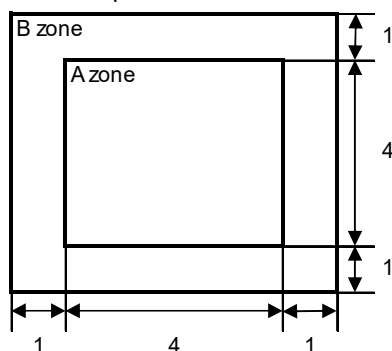

Division of A and B areas

B area: Active area

Dimensional ratio between A and B areas: 1: 4: 1

(Refer to the left figure)

10.2 Screen and Other Appearance

Testing conditions

Observation distance: 30 cm

Illuminance: 1200 ~ 2000 lx

Item		Criteria	Remark
Polarizer	Flaw	Ignore invisible defect when the backlight is on.	Applicable area: Active area only (Refer to the section 3.2 Outward Form)
	Stain		
	Dirt		
	Bubble		
	Dust		
	Dent		
S case		No functional defect occurs	
FPC		No functional defect occurs	



11. Reliability Test

Test item		Test condition		number of failures / number of examinations
Durability test	High temperature storage	Ta = 95°C	500hrs	0 / 3
	Low temperature storage	Ta = -40°C	500hrs	0 / 3
	High temperature & high humidity storage	Ta = 60°C, RH = 90%, non condensing	500hrs	0 / 3
	High temperature operation	Tp = 85°C	500hrs	0 / 3
	Low temperature operation	Tp = -30°C	500hrs	0 / 3
	High temperature & high humidity operation	Tp = 40°C, RH = 90%, non condensing	500hrs	0 / 3
	Thermal shock storage	-40°C ↔ 95°C (30min / 30min)	100cycles	0 / 3
	Lightfastness	Xenon Blackpanel 63±3°C non-shower 450W/m ² (300~700nm) non-operating Integral dose 800MJ/m ²		0 / 3
Mechanical environmental test	Electrostatic discharge test (Non operation)	Confirms to EIAJ ED-4701/300, C=200pF, R=0Ω, V=±200V Each 3 times of discharge on and power supply and other terminals.		0 / 3
	Surface discharge test (Non operation)	C=250pF, R=100Ω, V=±12kV Each 5 times of discharge in both polarities on the center of screen with the case grounded.		0 / 3
	FPC tension test (FPC of LCD only)	Pull the FPC with the force of 3N for 10 sec. in the direction - 90-degree to its original direction.		0 / 3
	FPC bend test (FPC of LCD only)	Pull the FPC with the force of 3N for 10 sec. in the direction -180-degree to its original direction. Reciprocate it 3 times.		0 / 3
	Vibration test	Total amplitude 1.5mm, f=10~55Hz, X,Y,Z directions for each 2 hours		0 / 3
	Impact test	Use TOPPAN original jig (see next page) and make an impact with peak acceleration of 1000m/s ² for 6 msec with half sine-curve at 3 times to each X, Y, Z directions in conformance with JIS C 60068-2-27-2011.		0 / 3
Packing test	Packing vibration-proof test	Acceleration of 19.6m/s ² with frequency of 10→55→10Hz, X,Y, Z direction for each 30 minutes.		0 / 1 packing
	Packing drop test	Drop from 75cm high. 1 time to each 6 surfaces, 3 edges, 1 corner		0 / 1 packing

Note: Ta=ambient temperature Tp=Panel temperature

※ The profile of high temperature/humidity storage and High Temperature/humidity operation
(Pure water of over 10MΩ·cm shall be used.)

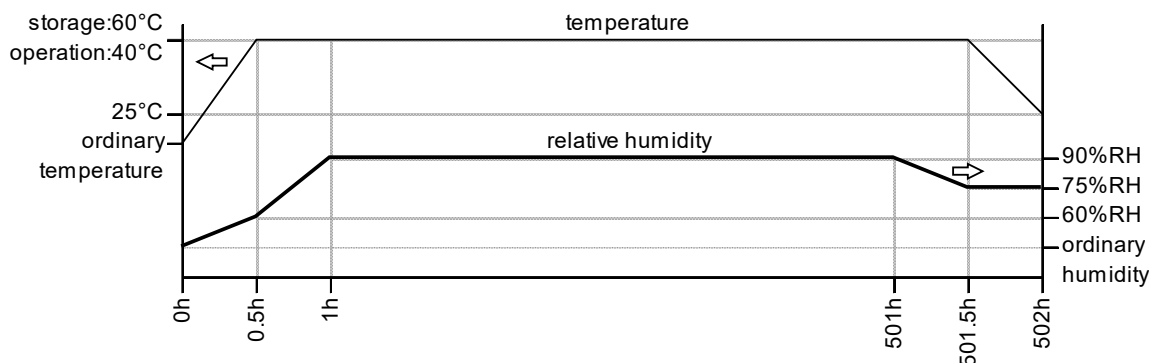
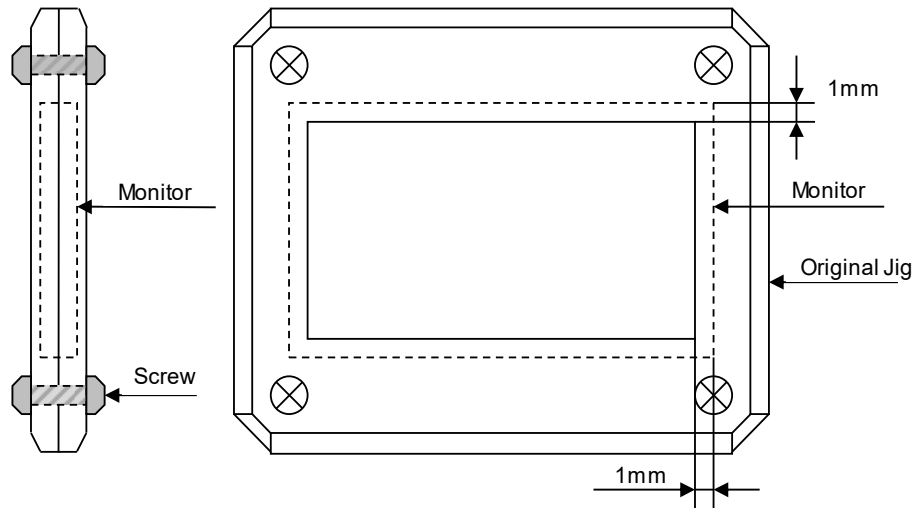

Table2. Reliability Criteria

The parameters should be measured after leaving the monitor at the ordinary temperature for 24 hours or more after the test completion.

Item	Standard	Remark
Display quality	No visible abnormality shall be seen. (Except for unevenness by PoI deterioration.)	
Contrast ratio	200 or more	Backlight ON

TOPPAN Original Jig



FPC tension test

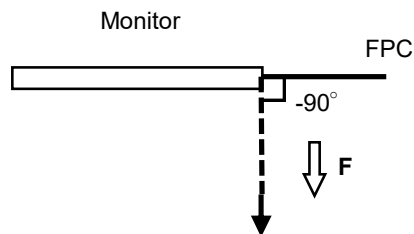

FPC bend test

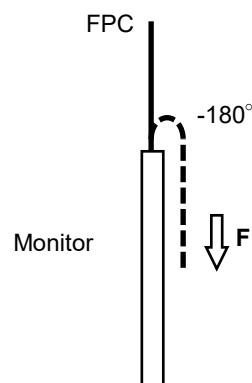

12. Packing Specifications

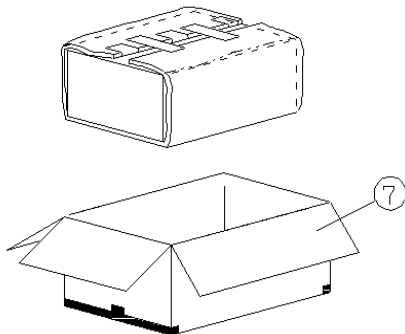
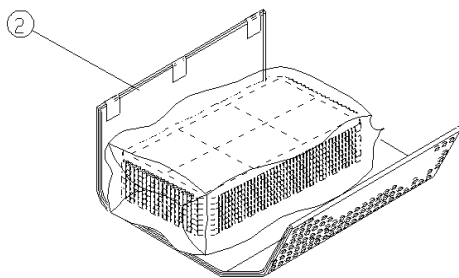
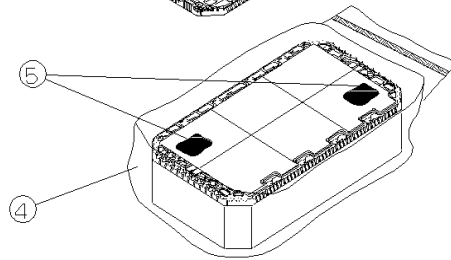
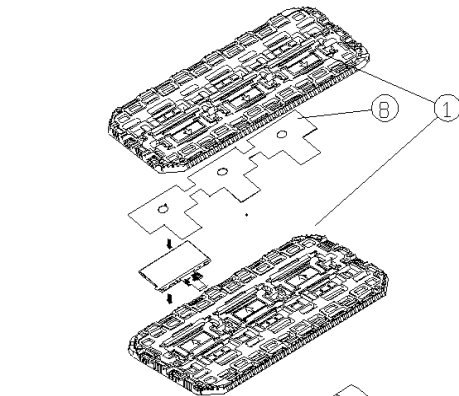

Step1. Each product is to be placed on the tray with its the display surface facing upward.(3 products per the tray)
Foam sheet is to be placed on the products in the tray.

Step2. Each tray needs to be stacked with 180 degrees alternate to the tray under or over it and the trays be in a stack of 8.
One empty tray is to be put on the top of stack of 8 packed trays.
When overlaying the tray, change the direction of 180 °.

Step3. 2 packs of moisture absorbers are to be placed on the top tray as shown in the drawing.
Put piled trays into a sealing bag.

Step4. Vacuum and seal the sealing bag with the vacuum sealing machine.

Step5. The stack of trays in the sealing bag is to be wrapped with a bubble cushioning sheet.

Step6. The wrapped trays are placed in the outer carton.

Step7. Bubble cushioning sheets are to be inserted into the outer carton with same orientation.
The outer carton is to be sealed in H-shape with packing tape as shown in the drawing.

Step8. The model number, quantity of products, and shipping date are to be printed on the outer carton.
If necessary, shipping labels or impression markings are to be put on the outer carton.

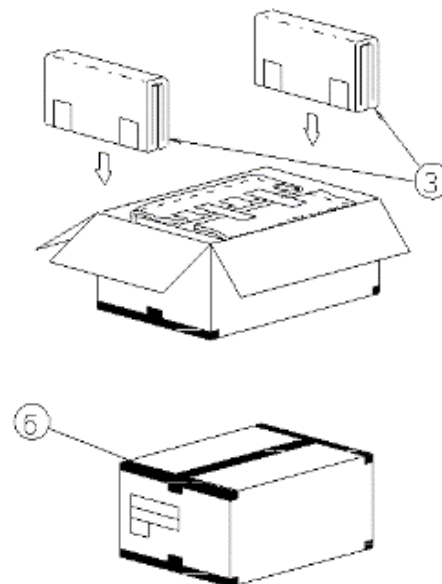

Remark: The return of packing materials is not required.

Packing item name	Specs., Material
① Tray	A-PET
② B SHEET C	Anti-static air bubble sheet
③ B SHEET D	Anti-static air bubble sheet
④ Sealing bag	
⑤ Drier	Moisture absorber
⑥ Packing tape	
⑦ Outer carton	Corrugated cardboard
⑧ FOAM SHEET	Anti-static polyethylene

Dimension of extra outer carton	
D : Approx.	(356 mm)
W : Approx.	(664 mm)
H : Approx.	(182 mm)
Quantity of products packed in one carton:	24
Gross weight : Approx.	5.0 kg

13. Handling Instruction

13.1 Cautions for Handling LCD panels



Caution

- (1) Do not make an impact on the LCD panel glass because it may break and you may get injured from it.
- (2) If the glass breaks, do not touch it with bare hands.
(Fragment of broken glass may stick you or you cut yourself on it.)
- (3) If you get injured, receive adequate first aid and consult a medial doctor.
- (4) Do not let liquid crystal get into your mouth.
(If the LCD panel glass breaks, try not let liquid crystal get into your mouth even toxic property of liquid crystal has not been confirmed.)
- (5) If liquid crystal adheres, rinse it out thoroughly.
(If liquid crystal adheres to your cloth or skin, wipe it off with rubbing alcohol or wash it thoroughly with soap. If liquid crystal gets into eyes, rinse it with clean water for at least 15 minutes and consult an eye doctor.)
- (6) If you scrap this products, follow a disposal standard of industrial waste that is legally valid in the community, country or territory where you reside.
- (7) Do not connect or disconnect this product while its application products is powered on.
- (8) Do not attempt to disassemble or modify this product as it is precision component.
- (9) If a part of soldering part has been exposed, and avoid contact (short-circuit) with a metallic part of the case etc. about FPC of this model, please.
Please insulate it with the insulating tape etc. if necessary.
The defective operation is caused, and there is a possibility to generation of heat and the ignition.
- (10) Since excess current protection circuit is not built in this TFT module, there is the possibility that LCD module or peripheral circuit become feverish and burned in case abnormal operation is generated.
We recommend you to add excess current protection circuit to power supply.
- (11) The devices on the FPC are damageable to electrostatic discharge, because the terminals of the devices are exposed.
Wear grounded wrist-straps and use electrostatic neutralization blowers to prevent static charge and discharge when handling the TFT monitors.
Designate an appropriate operating area, and set equipment, tools, and machines properly when handling this product.

Caution



This mark is used to indicate a precaution or an instruction which, if not correctly observed, may result in bodily injury, or material damages alone.

13.2 Precautions for Handling

- 1) Wear finger tips at incoming inspection and for handling the TFT monitors to keep display quality and keep the working area clean.
Do not touch the surface of the monitor as it is easily scratched.
- 2) Wear grounded wrist-straps and use electrostatic neutralization blowers to prevent static charge and discharge when handling the TFT monitors as the LED in this TFT monitors is damageable to electrostatic discharge.
Designate an appropriate operating area, and set equipment, tools, and machines properly when handling this product.
- 3) Avoid strong mechanical shock including knocking, hitting or dropping to the TFT monitors for protecting their glass parts.
Do not use the TFT monitors that have been experienced dropping or strong mechanical shock.
- 4) Do not use or storage the TFT monitors at high temperature and high humidity environment.
Particularly, never use or storage the TFT monitors at a location where condensation builds up.
- 5) Avoid using and storing TFT monitors at a location where they are exposed to direct sunlight or ultraviolet rays to prevent the LCD panels from deterioration by ultraviolet rays.
- 6) Do not stain or damage the contacts of the FPC cable .
FPC cable needs to be inserted until it can reach to the end of connector slot.
During insertion, make sure to keep the cable in a horizontal position to avoid an oblique insertion.
Otherwise, it may cause poor contact or deteriorate reliability of the FPC cable.
- 7) Do not bend or pull the FPC cable or carry the TFT monitor by holding the FPC cable.
Especially, it will cause mechanical damage or critical defect if FPC is pull up or bent up to short of display.

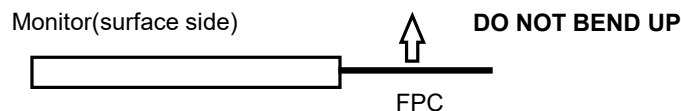

- 8) Peel off the protective film on the TFT monitors during mounting process.
Refer to the section 13.5 on how to peel off the protective film.
We are not responsible for electrostatic discharge failures or other defects occur when peeling off the protective film.

13.3 Precautions for Operation

- 1) Since this TFT monitors are not equipped with light shielding for the driver IC,
do not expose the driver IC to strong lights during operation as it may cause functional failures.
- 2) In case of powering up or powering off this LCD module,
be sure to comply the sequence as instructed in this specification.
- 3) Do not plug in or out the FPC cable while power supply is switch on.
Plug the FPC cable in and out while power supply is switched off.
- 4) Do not operate the TFT monitors in the strong magnetic field. It may break the TFT monitors.
- 5) Do not display a fixed image on the screen for a long time.
Use a screen-saver or other measures to avoid a fixed image displayed on the screen for a long time.
Otherwise, it may cause burn-in image on the screen due the characteristics of liquid crystal.

13.4 Storage Condition for Shipping Cartons

(Storage environment)

- Temperature 0 to 40° C
- Humidity 60%RH or less
No-condensing occurs under low temperature with high humidity condition.
- Atmosphere No poisonous gas that can erode electronic components and/or wiring materials should be detected.
- Time period 1 year
- Unpacking To prevent damages caused by static electricity, anti-static precautionary measures (e.g. earthing, anti-static mat) should be implemented.
After unpack, keep product in the appropriate condition, otherwise bubble seal of Protective film may be printed on Polarizer.
- Maximum piling up 8 cartons (excluding the bottom)

*Conditions to storage after unpacking

(Storage environment)

- Temperature 0 to 40° C
- Humidity 60%RH or less
No-condensing occurs under low temperature with high humidity condition.
- Atmosphere No poisonous gas that can erode electronic components and/or wiring materials should be detected.
- Time period 1 year (Shelf life)
- Others Keep/ store away from direct sunlight
Storage goods on original tray made by TOPPAN.

13.5 Precautions for Peeling off the Protective film

The followings work environment and work method are recommended to prevent the TFT monitors from static damage or adhesion of dust when peeling off the protective films.

A) Work Environment

- a) Humidity: 50 to 70 %RH, Temperature 15 to 27° C
- b) Operators should wear conductive shoes, conductive clothes, conductive finger tips and grounded wrist-straps.
Use an electrostatic neutralization blower.
- c) Anti-static treatment should be implemented to work area's floor.
Use a room shielded against outside dust with sticky floor mat laid at the entrance to eliminate dirt.

B) Work Method

The following procedures should taken to prevent the driver ICs from charging and discharging.

- a) Use an electrostatic neutralization blower to blow air on the TFT monitors to its lower left when FPC is placed at the bottom.
Optimize direction of the blowing air and the distance between the TFT monitors and the electrostatic neutralization blower.
- b) Peel off the Tab slowly (spending more than 2 secs to complete)
by pulling it to opposite direction.

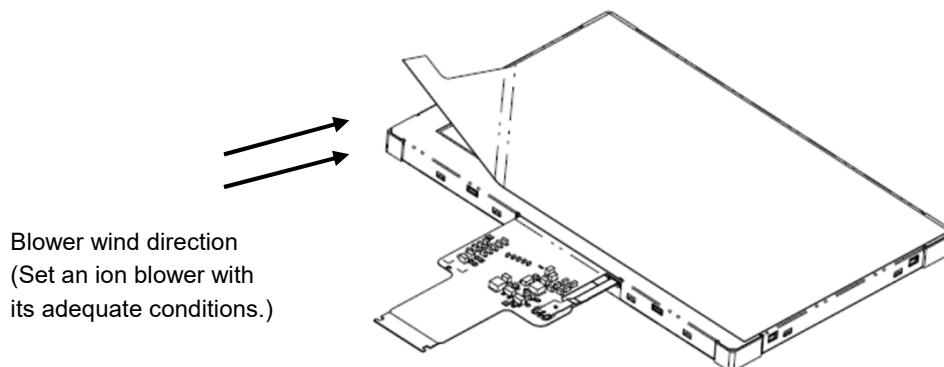

13.6 Warranty

TOPPAN is only liable to defective goods which is stored and used under the condition complying with this specifications and returned within 1 (one) year.

Warranty caused by manufacturing defect shall be conducted by replacement of goods or refundment at unit price.

APPENDIX

Reference Method for Measuring Optical Characteristics and Performance

1. Measurement Condition (Backlight ON)

Measuring instruments: CS2000 (KONICA MINOLTA), LCD7200 (OTSUKA ELECTRONICS), EZcontrastXL88 (ELDIM)

Driving condition: Refer to the section "Optical Characteristics"

Measured temperature: 25°C unless specified

Measurement system: See the chart below. The luminance meter is placed on the normal line of measurement system.

Measurement point: At the center of the screen unless otherwise specified

Dark box at constant temperature

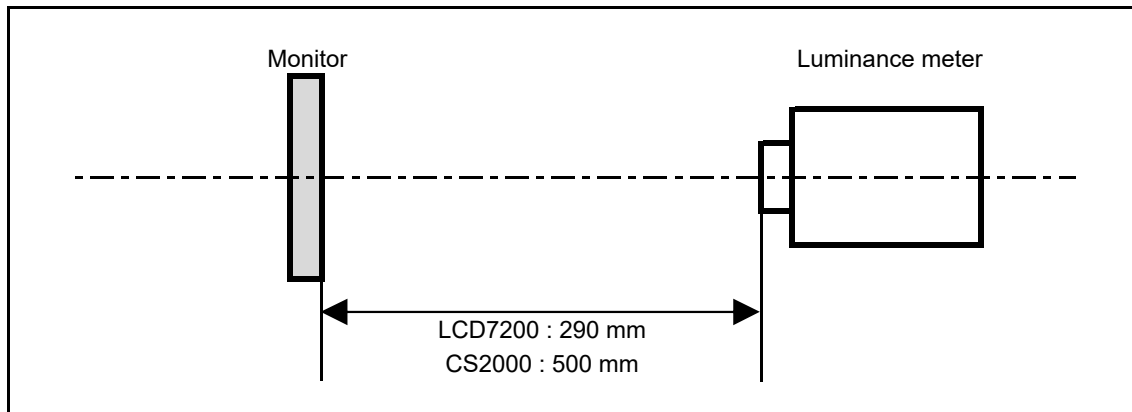

*Measurement is made after 30 minutes of lighting of the backlight.

Measurement point: At the center point of the screen

Brightness distribution: 9 points shown in the following drawing.

<Landscape model>

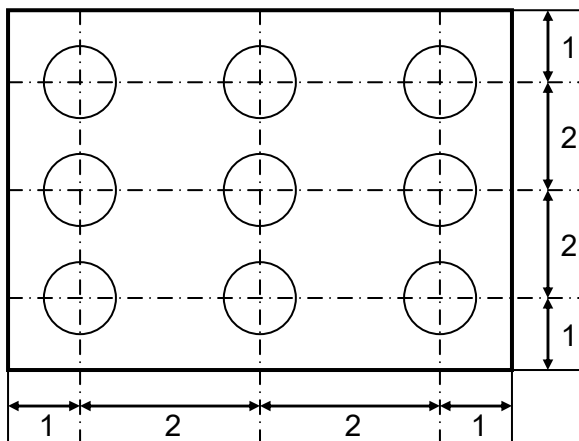

Dimensional ratio of active area

Backlight IL=20.0mA

Measurement Condition (Contrast ratio Backlight OFF only)

Measuring instruments: LCD7200(OTSUKA ELECTRONICS) , Ring Light (40,000 lx, $\phi 58$)

Driving condition: Refer to the section "Optical Characteristics"

Measured temperature: 25°C unless specified

Measurement system: See the chart below.

Measurement point: At the center of the screen unless otherwise specified

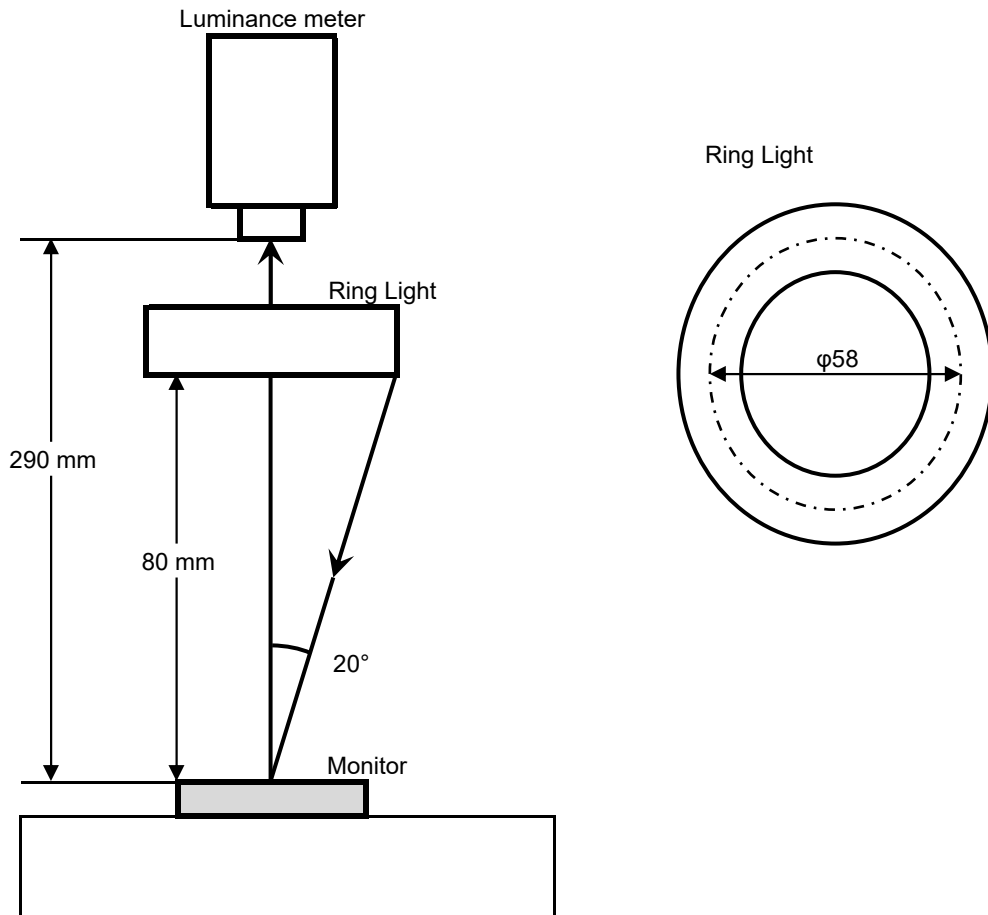

2. Test Method

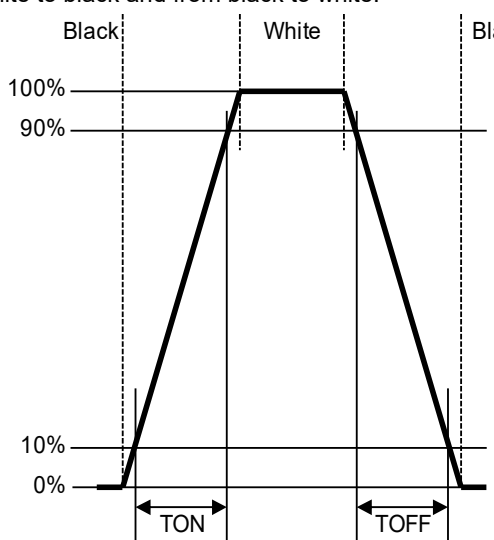
Notice	Item	Test method	Measuring instrument	Remark
1	Response time	Measure output signal waveform by the luminance meter when raster of window pattern is changed from white to black and from black to white. 	LCD7200	Black display [Data]=00h White display [Data]=FFh TON Rise time TOFF Fall time
2	Contrast ratio	Measure maximum luminance Y1([Data]=FFh) and minimum luminance Y2([Data]=00h) at the center of the screen by displaying raster or window pattern. Then calculate the ratio between these two values. $\text{Contrast ratio} = Y1/Y2$ Diameter of measuring point: 7.8mmφ(CS2000) Diameter of measuring point: 3mmφ(LCD7200)	CS2000 LCD7200	Backlight ON Backlight OFF
3	Viewing angle Horizontalθ Verticalφ	Move the luminance meter from right to left and up and down and determine the angles where contrast ratio is 10.	EZcontrastXL88	
4	White chromaticity	Measure chromaticity coordinates x and y of CIE1931 colorimetric system at [Data] = FFh Color matching function: 2°view measurement angle: 1°	CS2000	
5	Center brightness	Measure the brightness at the center of the screen.	CS2000	
6	Brightness distribution	$(\text{Brightness distribution}) = 100 \times B/A \%$ A : max. brightness of the 9 points B : min. brightness of the 9 points	CS2000	
7	Burn-in	Visually check burn-in image on the screen after 2 hours of "window display" ([Data]=00h/FFh).		At optimized VCOMDC