

The information provided herein is from CONNELY Electronic Co., Ltd. and is confidential. Any disclosure to a party other than the recipient is prohibited. The intellectual properties and its rights contained herein, including but not limited to, trademarks, patents, copyrights, trade secrets, and technical know-how, are owned exclusively by CONNELY or its affiliates. Unauthorized use of this information in any format or manner. CONNELY may enforce its intellectual property rights at its own discretion; failures or delays to exercise such rights does not constitute a waiver of such rights.

1                      2                      3                      4                      5                      6                      7                      8

| REV. | DESCRIPTION | DRAWN         | CHECKED | APPROVED |
|------|-------------|---------------|---------|----------|
| A    | NEW RELEASE | JLZ 04/14/18' |         |          |
|      |             |               |         |          |
|      |             |               |         |          |

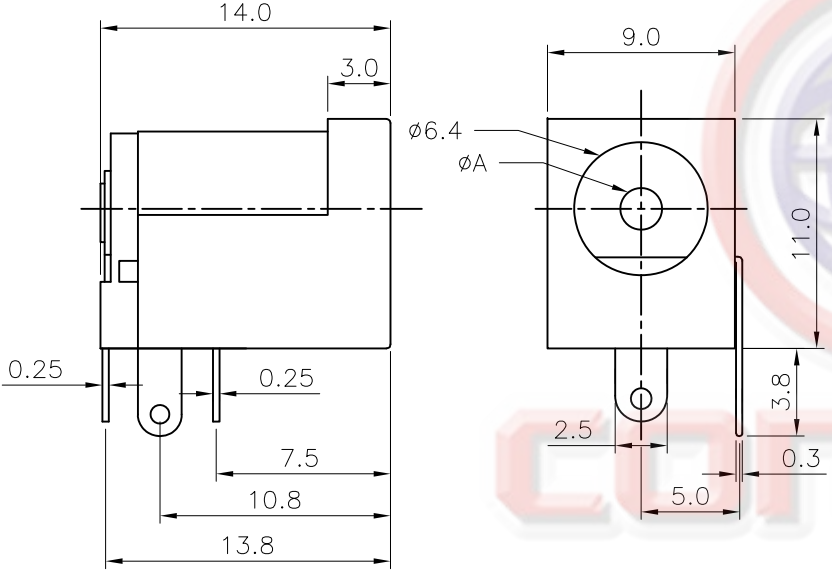

- NOTES:
- ELECTRICAL CHARACTERISTICS:
    - CONTACT RESISTANCE: 30mΩ Max.
    - DIELECTRIC WITHSTANDING VOLTAGE: 250V AC(rms) FOR 1 MINUTE.
    - INSULATION RESISTANCE: 100MΩ Min.
    - CURRENT RATING:3A.
  - ENVIRONMENT CHARACTERISTICS:
    - TEMPERATURE: -25°C~+70°C.
  - MATERIALS
    - CONTACT MATERIAL: COPPER ALLOY.
    - CONTACT PLATING: Ag
    - INSULATOR MATERIALS: PBT,BLACK.
  - PRODUCT NUMBER CODE:
 

DS1152-01 - X X X X X 0 X X

- Pin Dim. A type
  - 0: A=2.0mm
  - 1: A=2.5mm
- Packing type
  - P: Ploybag
- Housing color
  - B: Black
- Contact Plating
  - Y: Full Silver
- Mounting type
  - R: R/A type
- Connector type
  - S: Socket
- No.OF CONTACTS
  - 03

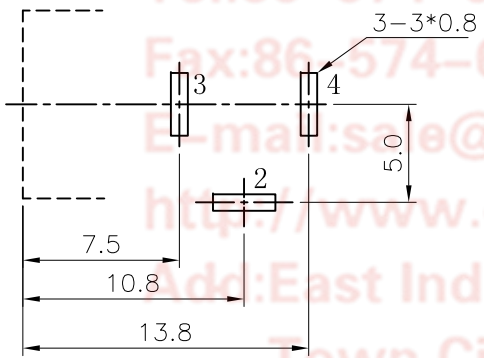
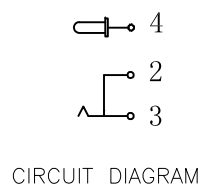

Tel:86-574-63508787  
 Fax:86-574-63510817  
 E-mail:sale@connfly.com  
 http://www.connfly.com  
 Add:East Industry Zone KuangYan  
 Town Cixi Ningbo China  
 P.C:315333

| GENERAL TOLERANCE |       | ANGLE TOLERANCE        |       | PROJECTION | TITLE                         |        |                  |
|-------------------|-------|------------------------|-------|------------|-------------------------------|--------|------------------|
| X.                | ±0.60 | X.                     | ±5°   |            | ∅6.4mm DC Power Jack R/A Type |        |                  |
| .X                | ±0.38 | .X                     | ±3°   | mm         |                               |        |                  |
| .XX               | ±0.25 | .XX                    | ±2°   | UNITS      | SHEET SIZE                    |        |                  |
| DRAWING TYPE      |       |                        |       | CUSTOMER   | A4                            | SERIES | DS1152-01 SERIES |
| SCALE             |       | 1:1                    | SHEET | 1 OF 1     |                               |        |                  |
| DRAWING NO.       |       | C-DS1152-01-XXXXX0XX-A |       |            |                               |        |                  |

**晨翔电子有限公司**  
**CONNFLY CONNELY ELECTRONIC CO. LTD**

1                      2                      3                      4                      5                      6                      7                      8