

Specifications for
Blanview TFT-LCD Monitor
(2.7" QVGA 240 x RGB x 320 Portrait)

Version 1.0

(Please be sure to check the specifications latest version.)

MODEL COM27H2P92UTC

Customer's Approval

Signature :

Name :

Section :

Title :

Date :

ORTUSTECH



TOPPAN INC.
Electronics Division
Technological Development Department III

Approved by

S. Epuclii

Checked by

J. Matsuzaki

Prepared by

M. Tojo

Version History

Ver.	Date	Page	Description	
0.0	Oct.4,2022	-	-	Tentative issue
1.0	May.24,2023	-	-	First issue
 ×23		P.1		Cover
			Change	Department name
		P.3		Contents
			Add	Contents
			Change	Page №
		P.5		2.2 Display Method
			Add	Items
			Correct	Signal input method
		P.11		4. Pin Assignment
			Correct	Pin Assignment
		P.12		5. Absolute Maximum Rating
			Delete	Condition
				6. Recommended Operating Conditions
			Correct	Rating
		P.13		7.1 DC Characteristics
			Correct	Symbol,Condition
			Correct	Note
		P.16		8.1 Interface
			Add	Contents
		P.17		8.2 Command transfer
			Add	Contents
		P.18-20		8.3 Data transfer
			Add	Contents
P.21,22		9.1 Power ON Sequence		
	Correct	Sequence		
P.23		9.2 Sleep IN Sequence		
	Correct	Table head		
		9.3 Sleep OUT Sequence		
	Correct	Table head		
		9.4 Power OFF Sequence		
	Correct	Table head		
P.24,25		9.5 Refresh Sequence		
	Correct	Sequence		
P.26		9.6 Power ON/OFF timing		
	Correct	Contents		
P.30		13.1 Defective Display and Screen Quality		
	Add	Signal condition		
P.31		13.2 Screen and Other Appearance		
	Add	Criteria (Glass chipping)		
P.32		14. Reliability Test		
	Add	number of failures / number of examinations		
	Add	Applied voltage		

Contents



1. Application	4
2. Outline Specifications		
2.1 Features of the Product	5
2.2 Display Method	5
3. Dimensions and Shape		
3.1 Dimensions	7
3.2 Outward Form	8
3.3 Serial № print (S-print)	10
4. Pin Assignment	11
5. Absolute Maximum Rating	12
6. Recommended Operating Conditions	12
7. Electrical Characteristics		
7.1 DC Characteristics	13
7.2 AC Characteristics	15
8. Interface		
8.1 Interface	16
8.2 Command transfer	17
8.3 Data transfer	18
9. Sequence		
9.1 Power ON Sequence	21
9.2 Sleep IN Sequence	23
9.3 Sleep OUT Sequence	23
9.4 Power OFF Sequence	19
9.5 Refresh Sequence	24
9.6 Power ON/OFF timing	26
10. LED Circuit	27
11. Touch Panel Circuit	27
12. Characteristics		
12.1 Optical Characteristics	28
12.2 Temperature Characteristics	29
13. Criteria of Judgment		
13.1 Defective Display and Screen Quality	30
13.2 Screen and Other Appearance	31
14. Reliability Test	32
15. Packing Specifications	34
16. Handling Instruction		
16.1 Cautions for Handling LCD panels	35
16.2 Precautions for Handling	36
16.3 Precautions for Operation	36
16.4 Storage Condition for Shipping Cartons	37
16.5 Precautions for Peeling off the Protective film	38
16.6 Warranty	38
APPENDIX	39

1. Application

This Specification is applicable to 68.4 mm (2.7 inch) Blanview TFT-LCD monitor with Touch Panel for non-military use.

- ◎ TOPPAN makes no warranty or assume no liability that use of this Product and/or any information including drawings in this Specification by Purchaser is not infringing any patent or other intellectual property rights owned by third parties, and TOPPAN shall not grant to Purchaser any right to use any patent or other intellectual property rights owned by third parties. Since this Specification contains TOPPAN's confidential information and copy right, Purchaser shall use them with high degree of care to prevent any unauthorized use, disclosure, duplication, publication or dissemination of TOPPAN's confidential information and copy right.
- ◎ If Purchaser intends to use this Products for an application which requires higher level of reliability and/or safety in functionality and/or accuracy such as transport equipment (aircraft, train, automobile, etc.), disaster-prevention/security equipment or various safety equipment, Purchaser shall consult TOPPAN on such use in advance.
- ◎ This Product shall not be used for application which requires extremely higher level of reliability and/or safety such as aerospace equipment, telecommunication equipment for trunk lines, control equipment for nuclear facilities or life-support medical equipment.
- ◎ It must be noted as an mechanical design manner, especial attention in housing design to prevent arcuation/flexure caused by stress to the LCD module shall be considered.
- ◎ TOPPAN assumes no liability for any damage resulting from misuse, abuse, and/or miss-operation of the Product deviating from the operating conditions and precautions described in the Specification.
- ◎ It shall be mutually conferred if nonconforming defect which result from unspecified cause in this specification arises.
- ◎ If any issue arises as to information provided in this Specification or any other information, TOPPAN and Purchaser shall discuss them in good faith and seek solution.
- ◎ TOPPAN assumes no liability for defects such as electrostatic discharge failure occurred during peeling off the protective film or Purchaser's assembly process.
- ◎ This Product is compatible for RoHS(2.0) directive.

Object substance	Maximum content [ppm]
Cadmium and its compound	100
Hexavalent Chromium Compound	1000
Lead & Lead compound	1000
Mercury & Mercury compound	1000
Polybrominated biphenyl series (PBB series)	1000
Polybrominated biphenyl ether series (PBDE series)	1000
Bis(2-ethylhexyl)phthalate series(DEHP series)	1000
Butyl benzyl phthalate series(BBP series)	1000
Dibutyl phthalate series(DBP series)	1000
Diisobutyl phthalate series(DIBP series)	1000

2. Outline Specifications

2.1 Features of the Product

- 2.7 inch diagonal display, 720 [H] x 320 [V] dots. 240RGB x 320 pixel.
- 6-bit / 262,144 colors.
- Single power supply operation of 2.7V.
- Timing generator [TG], Counter-electrode driving circuitry, Built-in power supply circuit.
- Long life & High bright white LED back-light.
- Blanview TFT-LCD, improved outdoor visibility.

	Indoor		Outdoor	
	Readability	Power Efficiency (Battery Life)	Readability	Power Efficiency (Battery Life)
Transmissive	Good	Good	Fair	Poor
Transflective	Fair	Poor	Good	Good
Blanview	Good	Good	Good	Good

2.2 Display Method

Items	Specifications	Remarks
Display type	VA type 262,144 colors Blanview, Normally Black	
Driving method	a-Si TFT Active matrix Line-scanning, Non-interlace	
Dot arrangement	RGB stripe arrangement	Refer to "Dot arrangement"
Signal input method	6-bit CPU interface	
Backlight type	Long life & High bright white LED	
Touch panel	Resistance type,transmissive analog tablet	Surface finishing:Clear
NTSC ratio	50%	

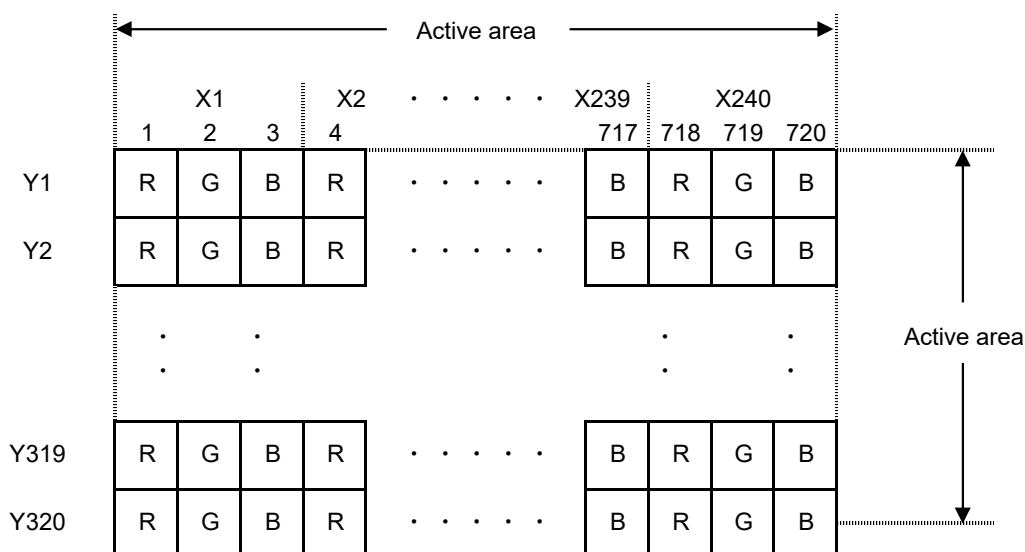

Dot arrangement (FPC cable placed left side)

<Features of Blanview>

- Backlight power consumption required to assure visibility. (equivalent to 3.5"QVGA)

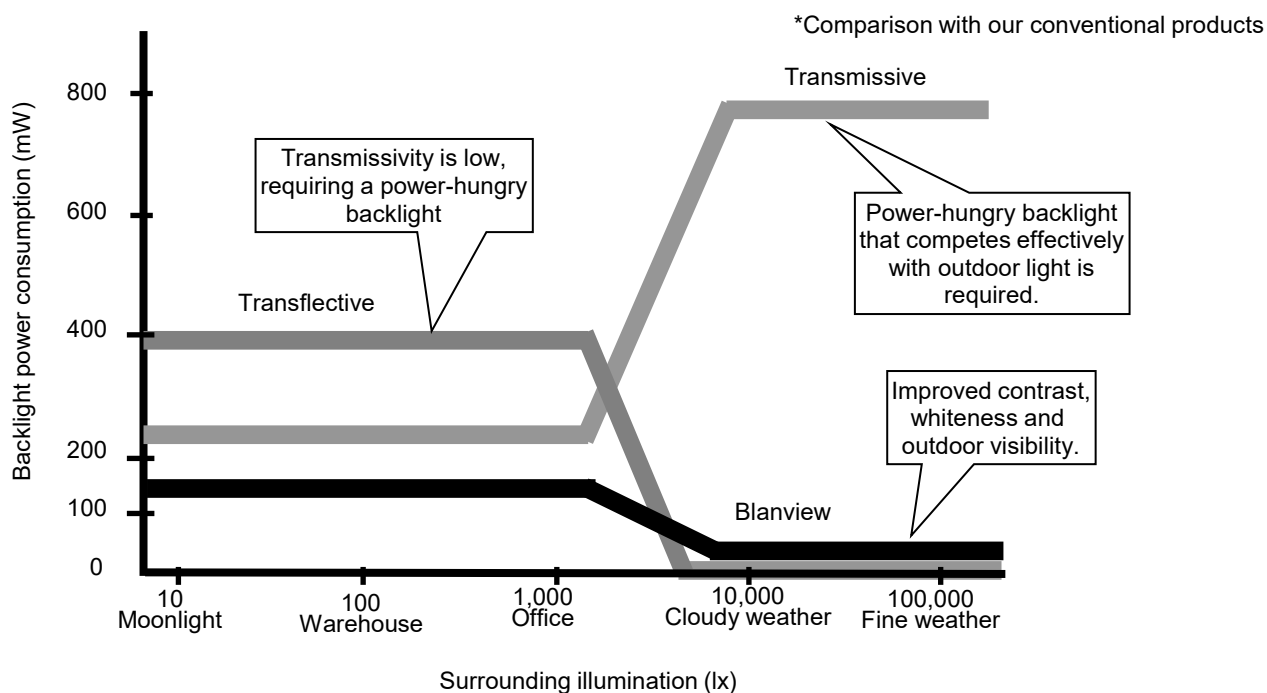

- Contrast characteristics under 100,000lx. (same condition as direct sunlight.)

With better contrast (higher contrast ratio), Blanview TFT-LCD has the best outdoor readability in three different types of TFT-LCD.

Below chart shows contrast value against panel surface brightness. (Horizontal: Panel surface brightness/ Vertical: Contrast value) LCD panel has enough outdoor readability above our Standard line. (TOPPAN criteria)

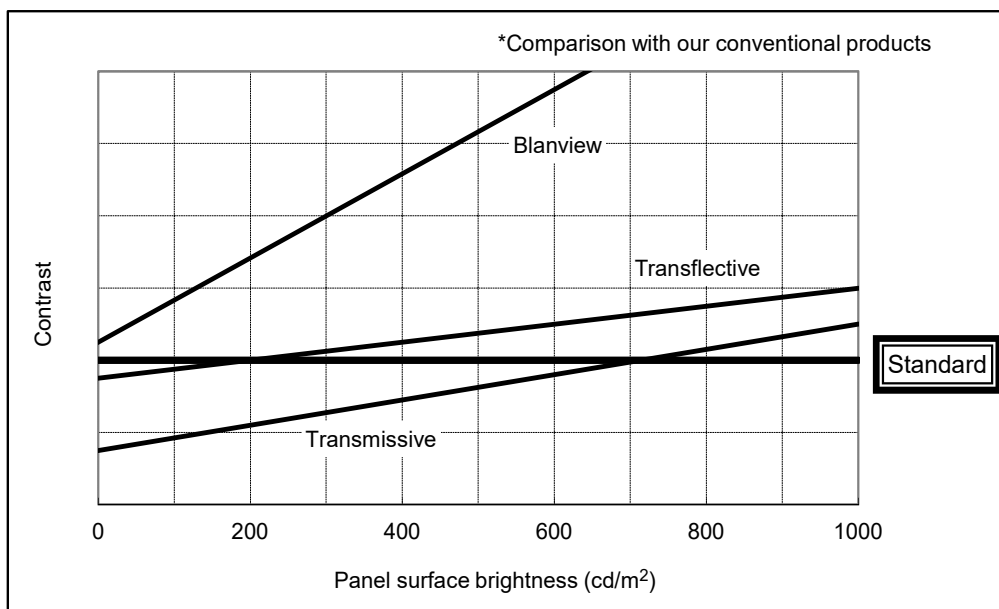

3. Dimensions and Shape

3.1 Dimensions

Items	Specifications	Unit	Remarks
Outline dimensions	47.00[H] × 66.00[V] × 4.19[D]	mm	exclude FPC and components on the FPC
Active area	41.04[H] × 54.72[V]	mm	68.4mm diagonal
Number of dots	720[H] × 320[V]	dot	
Dot pitch	57.0[H] × 171.0[V]	um	
Hardness of Touch Panel surface	3	H	
Weight	25.0	g	Include FPC cable

3.2 Outward Form

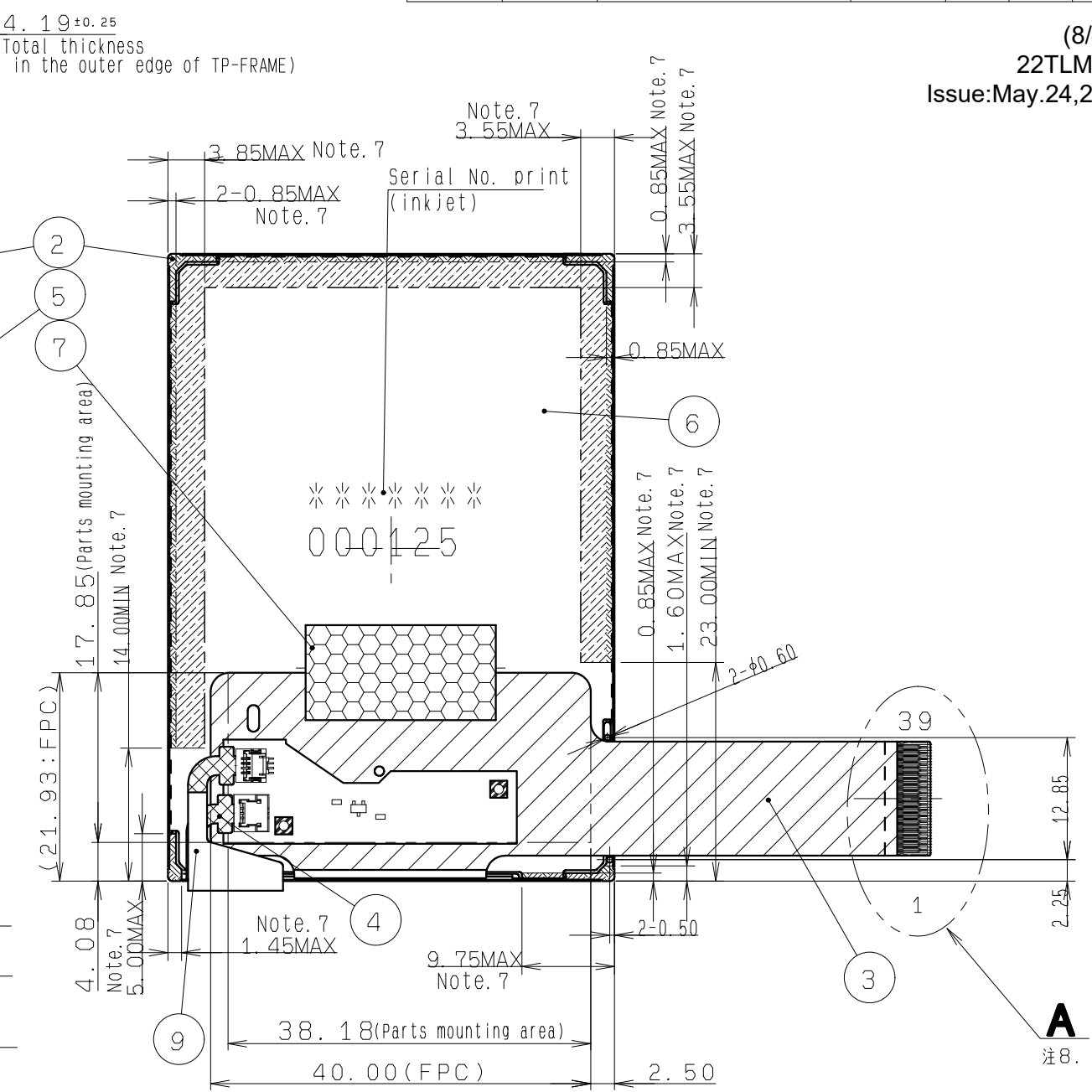
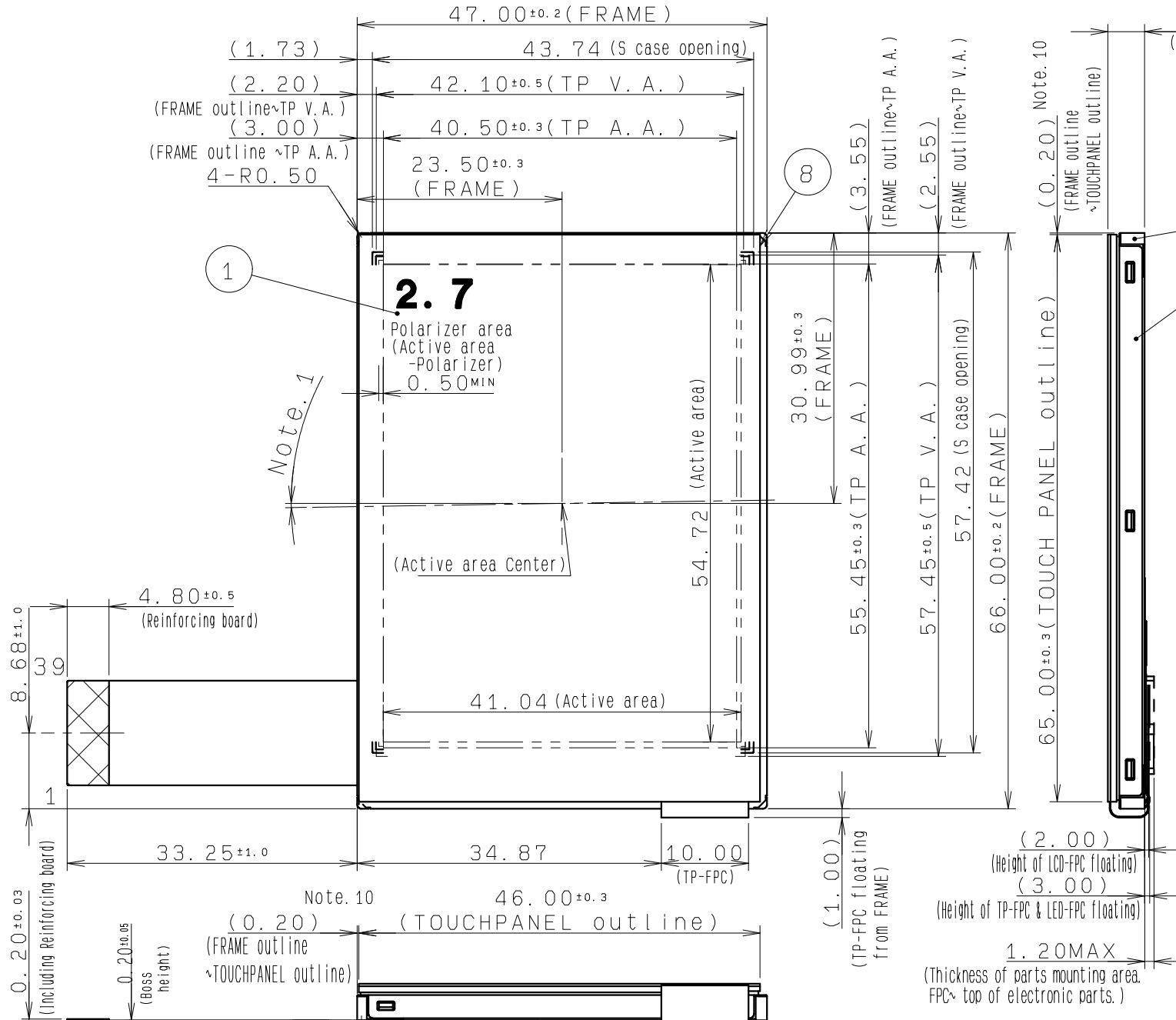

- Note 1. Angular deviation of LCD cell from the TFT-LCD monitor's reference axis shall be less than [±40'].
- Note 2. Recommended FPC connectors
For LCD : HIROSE, part number: FH23-39S-0.3SHW(05)
- Note 3. Protective film is affixed on front surface of the screen.
Location tolerance of the protective film shall be ±1.5 mm to the polarizing film.
- Note 4. Keep a gap, for example 0.3 to 0.7mm between the bezel edge and T/P surface to avoid the bezel edge from making contacting with the T/P surface that may cause a "false touch" with the bottom layer.
- Note 5. Bezel Opening design:
It is recommended to design based on LCD Active area and LCD Active area center.
Please place the bezel opening to maintain the operation by a stylus pen or finger inside the T/P response area. (Refer to "Example of housing design")
The dimensions shown (note6) in drawing are One example of the bezel design.
- Note 6. Linearity is guaranteed in the area surrounded by 3mm inside lines from TOUCHPANEL Active Area.
- Note 7. In case TFT-LCD monitor is fixed to the case of your product, it's recommended that monitor is fixed in to area. If the burden on area are smaller than area, these area can be used too. Please choose a size implement the test.
- Note 8. Refer to "4. PIN ASSIGNMENT" about the pin No. of TOUCHPANEL.
- Note 9. Refer to "14. CRITERIA OF JUDGMENT" about the appearance specification of a polarizer.
- Note 10. Touch Panel fits in the outer shape of the frame.

	10		
FPC C	9		Use for TP
TOUCH PANEL	8		Glass substrate thickness=0.7t Surface finishing: Clear
I-TAPE	7		t=0.05
S CASE C	6		SUS304
S CASE A	5		SUS304
FPC B	4		Use for LED
FPC A	3		Use for LCD
FRAME	2		PC
LCD	1		Glass substrate thickness=0.5t
PART NAME	ITEM	PART CODE	MODEL NUMBER
			REMARK

APPROVED 木下大輔	GENERAL TOLERANCE ±0.5	SCALE Free	UNIT mm
CHECKED 加藤真一	ISSUE (Y:M:D) 23:04:20	MODEL COM27H2P92U**	
CHECKED	NAME		DO NOT DUPLICATE, CONFIDENTIAL AND PROPRIETARY
DESIGN 富田恵太	OUTLINE-D2P92		DRAWING No. RJD603980D301
DRAW 富田恵太			REV. SHEET DIV. # 1/2 ASS'Y

EC No.	REV. No.	REVISE	DATE (Y:M:D)	APPROVED	CHECKED	PREPARED
###			##:##:##	##	##	

(9/43)
22TLM052
Issue: May.24,2023

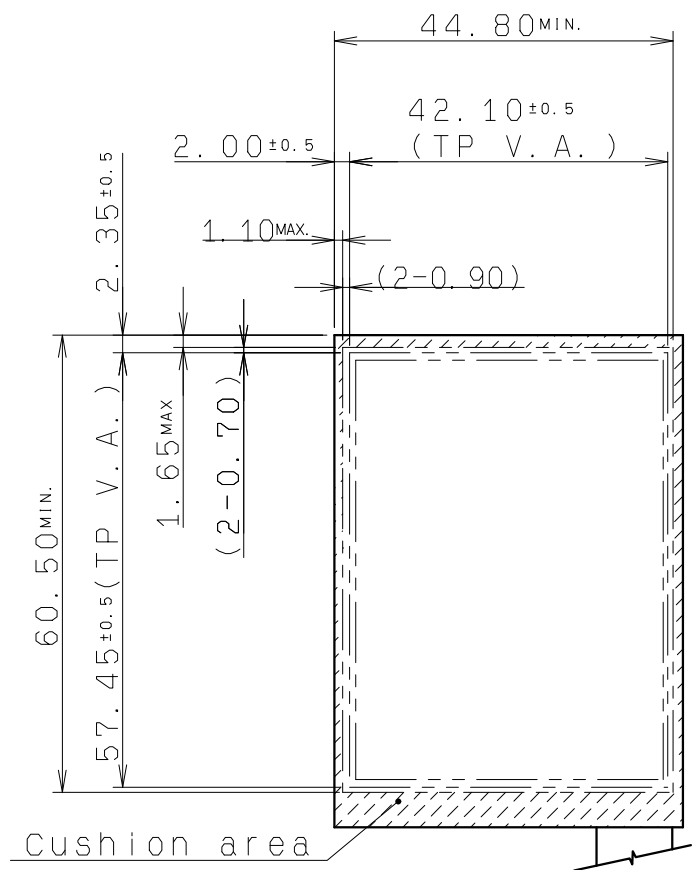
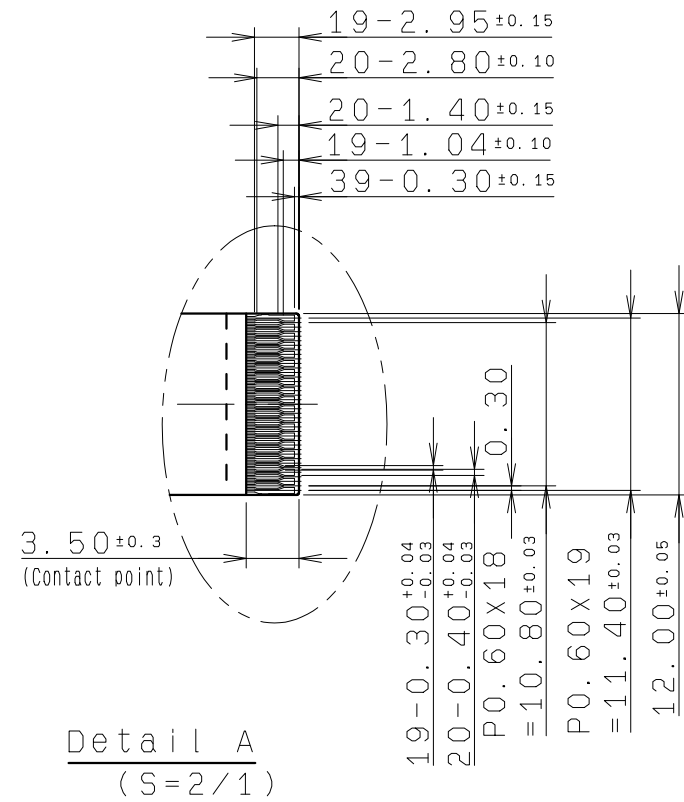

Example of Housing Design

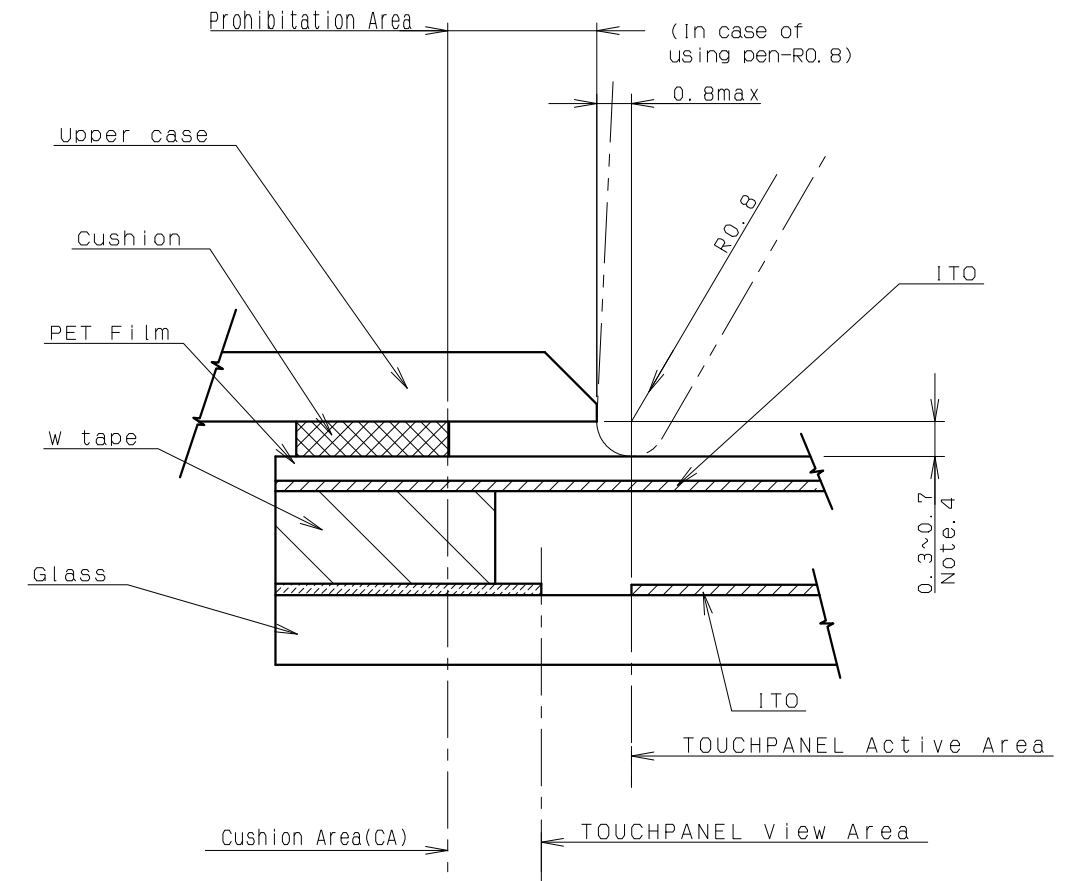

Design guidance for the upper case & the cushion

Note 11. Upper case opening

- a. Please place the upper case opening to maintain the operation by a stylus pen inside the TP response area
- b. Please use the appropriate material (PMMA, PC, etc.) as the upper case.

Note 12. Cushion design

- a. Please put the cushion on the upper case.
- b. Do not use an adhesive tape to stick on the TP surface.
- c. Please position the cushion over the cushion area to avoid a short.

APPROVED 木下大輔	GENERAL TOLERANCE ±0.5	SCALE Free	UNIT mm	TOPPAN TOPPAN INC. DO NOT DUPLICATE, CONFIDENTIAL AND PROPRIETARY				
CHECKED 加藤真一	ISSUE (Y:M:D) 23:04:20	MODEL COM27H2P92U**						
CHECKED	NAME			DRAWING No.	REV.	SHEET	DIV.	
DESIGN 富田恵太				OUTLINE-D2P92	RJD603980D301	#	2/2	
DRAW 富田恵太								

3.3 Serial № print (S-print)

3.3.1 Display Items

S-print indicates the least significant digit of manufacture year (1digit), manufacture month with below alphabet (1letter), model code (5characters), serial number (6digits).

* Contents of Display

*	*	*****	*****
-	-	-----	-----
a	b	c	d

Contents of display				
a	The least significant digit of manufacture year			
b	Manufacture month	Jan-A Feb-B Mar-C Apr-D	May-E Jun-F Jul-G Aug-H	Sep-I Oct-J Nov-K Dec-L
c	Model code	27HDC (Made in Japan) 27HEC (Made in Malaysia)		
d	Serial number			

* Example of indication of Serial № print (S-print)

- Made in Japan

2L27HDC000125

means "manufactured in December 2022, 2.7" HD type, C specifications, serial number 000125"

- Made in Malaysia

2L27HEC000125

means "manufactured in December 2022, 2.7" HE type, C specifications, serial number 000125"

3.3.2 Location of Serial № print (S-print)

Refer to 3.2 "Outward Form".

3.3.3 Others

Please note that it is likely to disappear with an organic solvent about the Serial print.



4. Pin Assignment

No.	Symbol	Function
1	VSS	GND
2	VSS	GND
3	VCI	Power supply for main circuit
4	IOVCC	Power supply for I/O circuit
5	VSS	GND
6	RESETB	Reset signal (Lo-active)
7	CSB	Chip selection signal (Lo: Select, Hi: Unselect)
8	RS	Register selection signal (Lo:command, Hi:parameter / Display data)
9	WRB	Write signal
10	VSS	GND
11	D0	Data I/O
12	D1	Data I/O
13	D2	Data I/O
14	D3	Data I/O
15	D4	Data I/O
16	D5	Data I/O
17	D6	Data I/O
18	D7	Data I/O
19	D8	Data I/O
20	D9	Data I/O
21	D10	Data I/O
22	D11	Data I/O
23	D12	Data I/O
24	D13	Data I/O
25	D14	Data I/O
26	D15	Data I/O
27	D16	Data I/O
28	D17	Data I/O
29	VSS	GND
30	BS0	Interface mode setting terminal
31	BS1	Interface mode setting terminal
32	RDB	Read signal
33	XL	X-axis left terminal
34	YD	Y-axis down terminal
35	XR	X-axis right terminal
36	YU	Y-axis up terminal
37	TE	Synchronization signal output
38	BLH	LED drive power source. (Anode side)
39	BLL	LED drive power source. (Cathode side)

Note :

- Recommended connector : Hirose FH23 series "FH23-39S-0.3SHW(05) "
- In the circuit design, the terminal array of connector for use with terminal sequence of the "3.2 Outward Form", please be sure to check.
If the array of the signal input to the product is different, it may cause a malfunction.
- FPC of the terminal has been decorated with gold-plated.
Connector contact terminals is recommended the use of gold-plated products.
- Interface mode setting terminals are fixed as follows on the FPC.
BS2=GND



5. Absolute Maximum Rating

VSS=0V

Item	Symbol	Condition	Rating		Unit	Applicable terminal
			MIN	MAX		
Supply voltage	VCI		-0.3	4.6	V	VCI
Supply voltage	IOVCC		-0.3	VCI	V	IOVCC
Input voltage for logic	VI		-0.3	IOVCC+0.3	V	RESETB,CSB,RS,WRB,D0-D17,BS0,BS1,RDB
LED Forward current	IL	Ta=25°C	—	35.0	mA	BLH - BLL
		Ta=70°C	—	15.0		
Touch Panel input voltage	VIT		—	7.0	V	XR,XL,YU,YD
Storage temperature range	Tstg		-30	80	°C	
Storage atmospheric range	Hstg	40°C90%RH or less of moisture content with no condensation				



6. Recommended Operating Conditions

VSS=0V

Item	Symbol	Condition	Rating			Unit	Applicable terminal
			MIN	TYP	MAX		
Supply voltage	VCI		2.6	2.7	3.6	V	VCI
Supply voltage	IOVCC		1.65	VCI	VCI	V	IOVCC
Input voltage for logic	VI		0	—	IOVCC	V	RESETB,CSB,RS,WRB,D0-D17,BS0,BS1,RDB
Operational temperature range	Top	*note	-20	25	70	°C	Touch Panel surface temperature
Operating humidity range	Hop	Ta ≤ 40°C	20	—	85	%	
		Ta > 40°C	40°C85%RH or less of moisture content with no condensation				

note : The maximum value of LED Forward current "IL", do not exceed the following allowable current value.

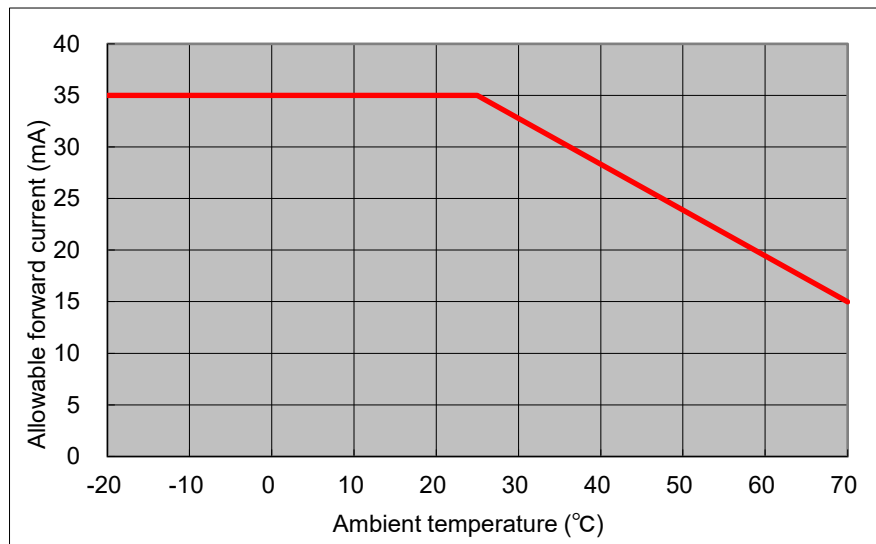

7. Electrical Characteristics



7.1 DC Characteristics

7.1.1 Display section

(Unless otherwise noted, Ta=25°C, VCI=2.7V, IOVCC=2.7V, VSS=0V)

Item	Symbol	Condition	Rating			Unit	Applicable terminal
			MIN	TYP	MAX		
Input Signal Voltage	VIH		0.7×IOVCC	—	IOVCC	V	RESETB,CSB,RS,WRB,
	VIL		0	—	0.3×IOVCC	V	D0-D17,BS0,BS1,RDB
Output Signal Voltage	VOH	IOH = -0.1mA	0.8×IOVCC	—	—	V	D0-D17,TE
	VOL	IOL = 0.1mA	—	—	0.2×IOVCC	V	
Operating Current	ICI	BS0=0	—	6.1	12.2	mA	VCI
	IOICC	Color bar *note	—	2	10	μA	IOVCC
		BS0=1	—	30	60	μA	
Standby Current	ICI	BS=0	—	6	30	μA	VCI
	IOICC	Other input with constant voltage	—	2	10	μA	IOVCC
		BS0=1	—	30	60	μA	

note : CPU is not accessing the display RAM, still image display state (Color bar display)

7.1.2 Backlight section

Item	Symbol	Condition	Rating			Unit	Applicable terminal
			MIN	TYP	MAX		
Forward current	IL25	Ta=25°C	—	7.0	35.0	mA	BLH - BLL
	IL70	Ta=70°C	—	—	15.0	mA	
Forward voltage	VL	Ta=25°C, IL=7.0mA	—	8.0	8.5	V	
Estimated Life of LED	LL	Ta=25°C, IL=7.0mA Note	—	50,000	—	hrs	

note :

- The lifetime of the LED is defined as a period till the brightness of the LED decreases to the half of its initial value.
- This figure is given as a reference purpose only, and not as a guarantee.
- This figure is estimated for an LED operating alone.
As the performance of an LED may differ when assembled as a monitor.
- Estimated lifetime could vary on a different temperature and usually higher temperature could reduce the life significantly.

7.1.3 Touch Panel

Ta=25° C

Item	Symbol	Condition	Rating			Unit	Applicable terminal
			MIN	TYP	MAX		
Linearity	LE	Note	-1.5	--	1.5	%	
Insulation resistance	RI	DC 25V	20	--	--	MΩ	XR,XL-YU,YD
Terminal resistance		X	200	--	900	Ω	XR,XL
		Y	200	--	900		YU,YD
Rated voltage		DC	--	5.0	7.0	V	XR,XL,YU,YD
on/off chattering		R0.8mm Polyacetal pen.	--	--	10	ms	

Note: -Linearity Measurement:Refer to the APPENDIX of "Reference Method for Measuring Optical Characteristics".
Load:2.45N

Mechanical Characteristics

Item	Rating			Unit	Remark
	MIN	TYP	MAX		
Detectable activation force	0.05	--	0.80	N	R0.8mm Polyacetal pen or finger. Resistance between X and Y axis must be equal or lower than 2kΩ.
Keystroke durability	1,000,000	--	--	times	key the same part by silicon rubber. (Touch panel Active area only) -Rubber tip part: R8mm -Load: 2.45N -speed: 2times/second

7.2 AC Characteristics

(Unless otherwise noted, $T_a=25^{\circ}\text{C}$, $V_{CI}=2.7\text{V}$, $\text{IOVCC}=2.7\text{V}$, $V_{SS}=0\text{V}$)

Item	Symbol	Condition	Rating		Unit
			MIN	MAX	
Address setup time	t_{AST}	RS	0	-	ns
Address hold time	t_{AHT}	RS	10	-	ns
CSB "High" level pulse width	t_{CHW}	CSB	0	-	ns
CSB setup time	t_{CS}	CSB-WRB	15	-	ns
	t_{RCSFM}	CSB-RDB	355	-	ns
CSB wait time	t_{CSF}	CSB	10	-	ns
CSB hold time	t_{CSH}	CSB	10	-	ns
WRB bus cycle time	t_{WC}	WRB	66	-	ns
WRB "High" level pulse width	t_{WRH}	WRB	15	-	ns
WRB "Low" level pulse width	t_{WRL}	WRB	15	-	ns
RDB bus cycle time	t_{RCFM}	RDB	450	-	ns
RDB "High" level pulse width	t_{RDHFM}	RDB	90	-	ns
RDB "Low" level pulse width	t_{RDLFM}	RDB	355	-	ns
WRB data setup time	t_{DST}	D17-D0	10	-	ns
WRB data hold time	t_{DHT}	D17-D0	10	-	ns
RDB data delay time	t_{RATFM}	D17-D0	-	340	ns
RDB output disable time	t_{DDH}	D17-D0	20	80	ns
Input signal rise time	t_r		-	15	ns
Input signal fall time	t_f		-	15	ns

All timing is defined as the reference to the 30-70% of IOVCC.

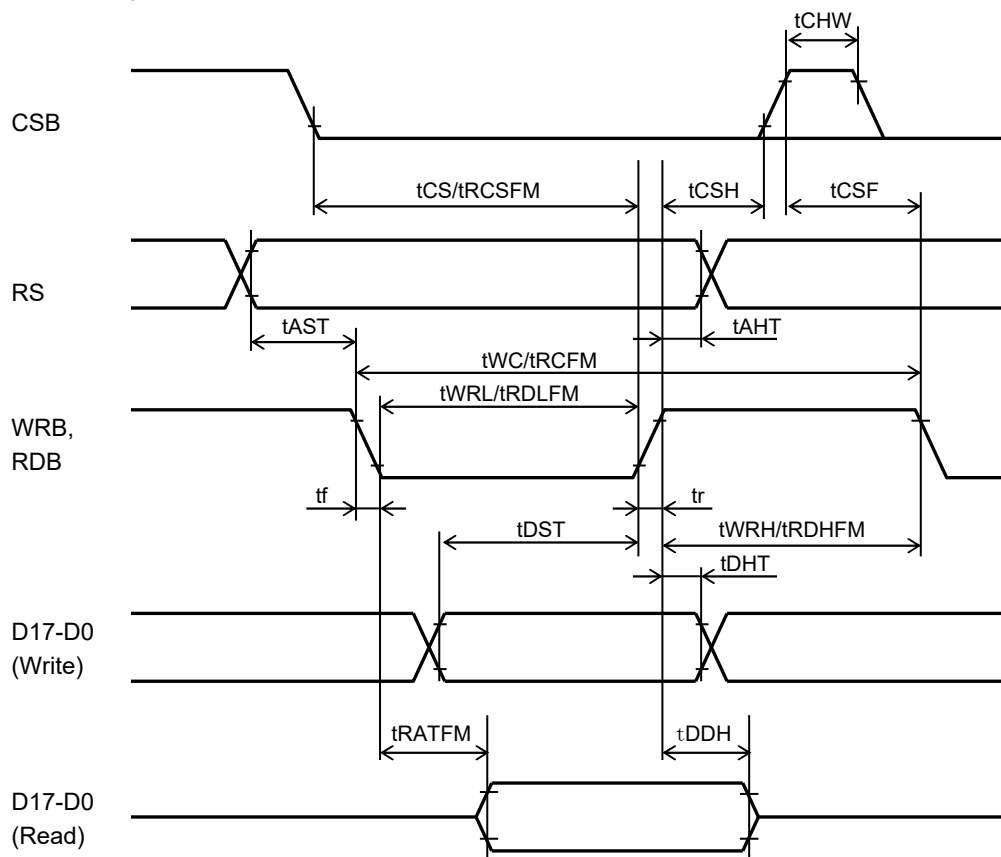

8. Interface

 8.1 Interface

Data width		Command /Parameter writing		Display RAM writing				
Transfer method				CPU				
1 pixel data				18bit	16bit	8bit		
BS1	*			18	16	6+6+6		
BS0	*			18	16	18		
R3Ah (Pixel Format)				H	L	H		
RB0h (RAM control Para2)				L	L	H		
				06h	05h	06h		
				E0h	E0h	E1h		
D17	*	R5						
D16	*	R4						
D15	*	R3	R5					
D14	*	R2	R4					
D13	*	R1	R3					
D12	*	R0	R2					
D11	*	G5	R1					
D10	*	G4	G5					
D9	*	G3	G4					
D8	*	G2	G3					
D7	ID7	G1	G2	R5	G5	B5		
D6	ID6	G0	G1	R4	G4	B4		
D5	ID5	B5	G0	R3	G3	B3		
D4	ID4	B4	B5	R2	G2	B2		
D3	ID3	B3	B4	R1	G1	B1		
D2	ID2	B2	B3	R0	G0	B0		
D1	ID1	B1	B2					
D0	ID0	B0	B1					

- note - When swiching the interface, it is necessary to change the BS PIN and register settings.
 - Unused terminal "D0~D17" should be connected to VSS.



8.2 Command transfer

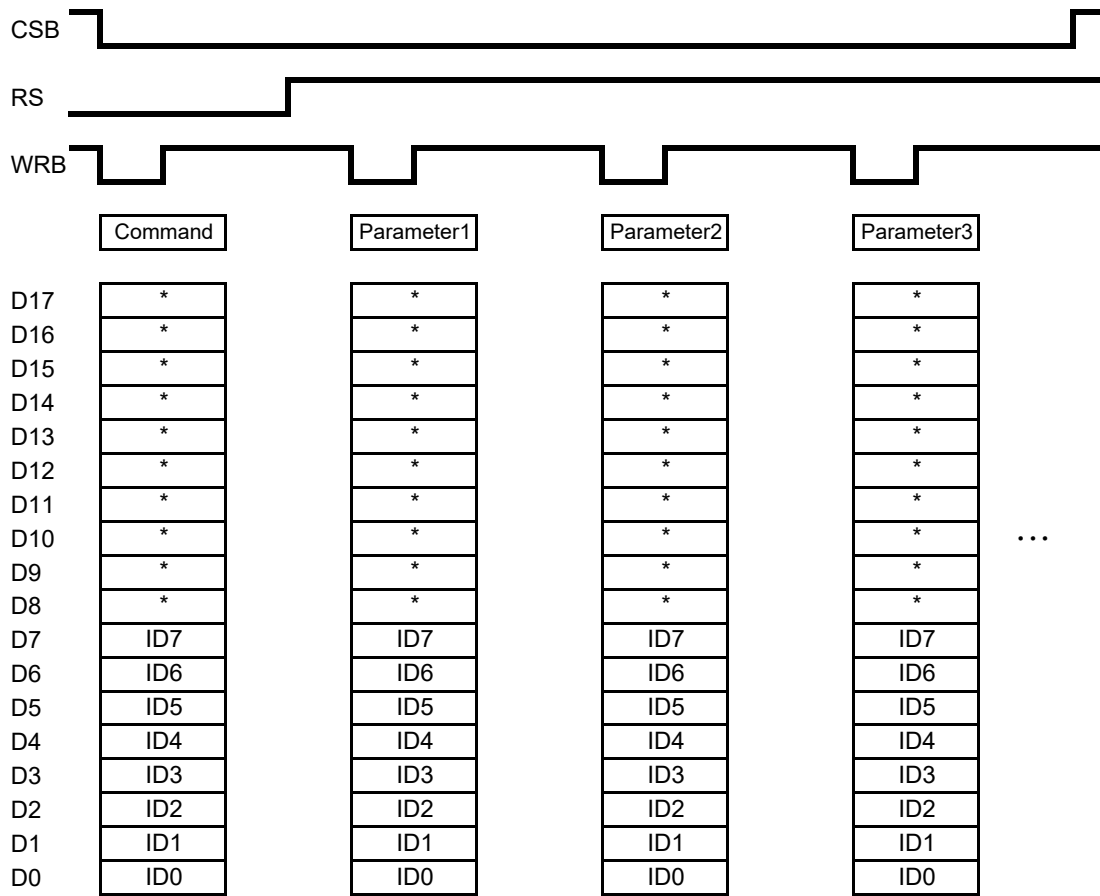

A 8.3 Data transfer

8.3.1 262k Display (18bpp) (R3Ah = 06h, RB0h para2 = E0h)

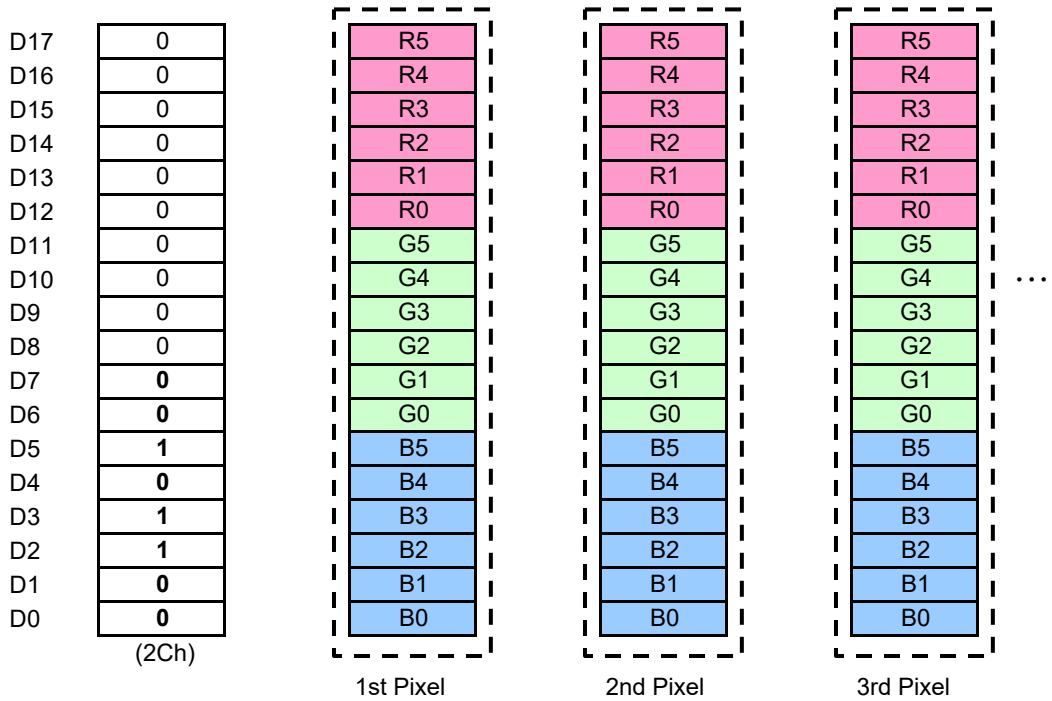
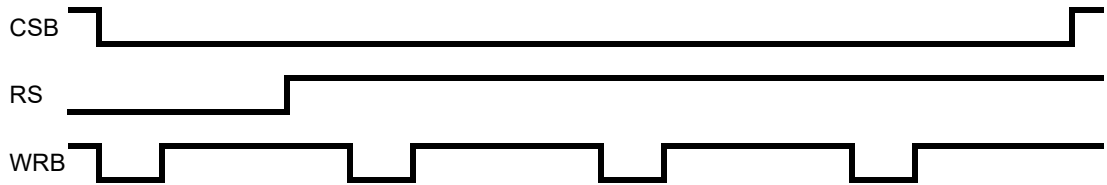



8.3.2 65k Display (16bpp) (R3Ah = 05h, RB0h para2 = E0h)

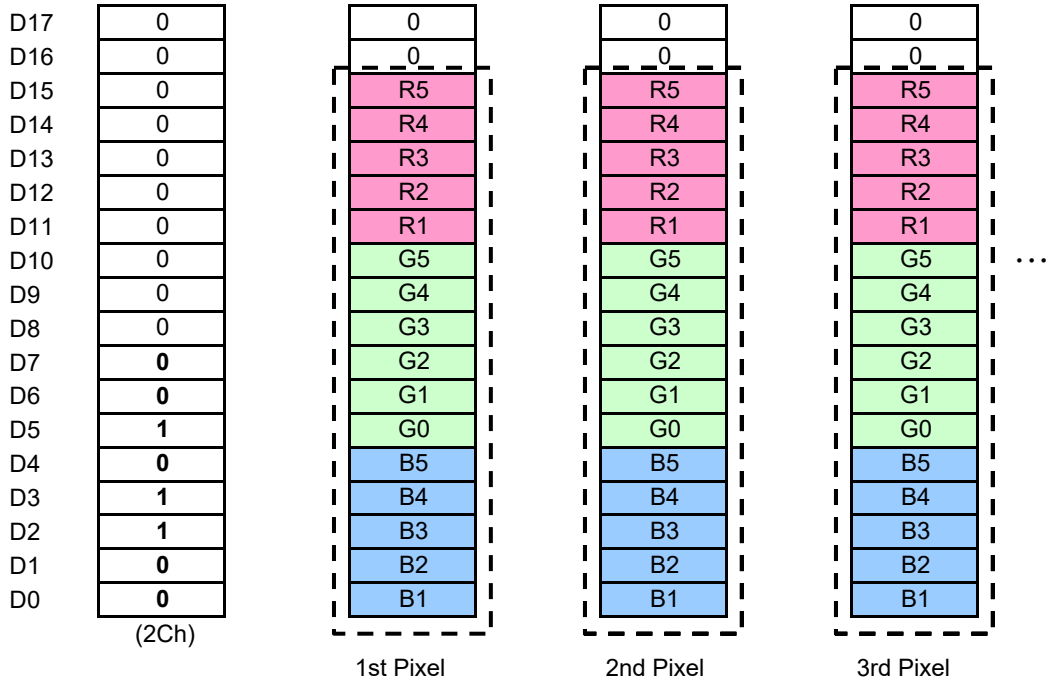
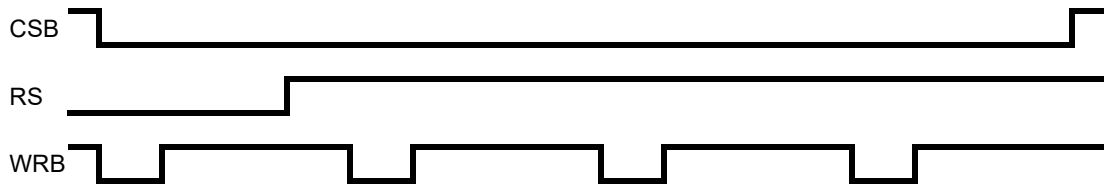



8.3.3 262k Display (18bpp) (R3Ah = 06h, RB0h para2 = E1h))

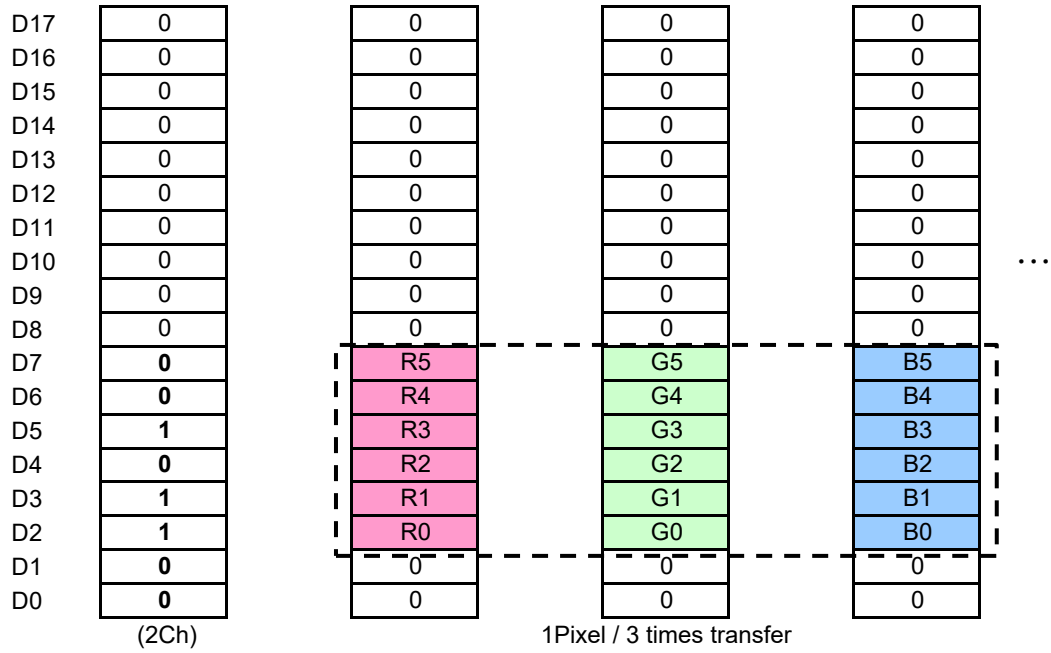
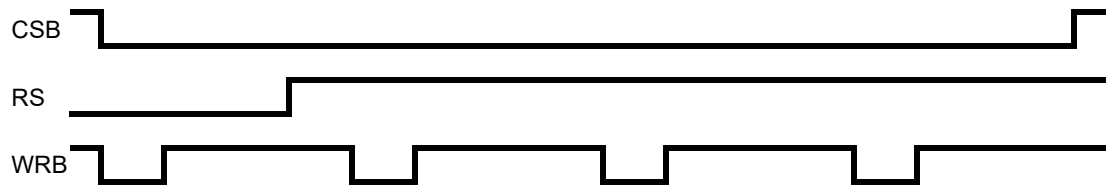

9. Sequence



9.1 Power ON Sequence

(1/2)

No.		RS	ID[7:0]	Remarks
	VCI/IOVCC ON			
	RESETB High	RESETB Low		RESETB High can be omitted
	RESETB High → Low			
	Wait 10 usec or more			
	RESETB Low → High			
	Wait 120 msec or more			
1	Sleep Out	0	11 h	
	Wait 120 msec or more			
2	Memory access control	0	36 h	
	para 1	1	00 h	MX=MY=0
3	LCM Control	0	C0 h	
	para 1	1	3C h	XINV=XMV=XXM=XBGR=1
4	Pixel format	0	3A h	
	para 1	1	05 h	05h:65k,06h:262k
5	CMD2EN	0	DF h	
	para 1	1	5A h	
	para 2	1	69 h	
	para 3	1	02 h	
	para 4	1	01 h	Command2 enable
6	GATECTRL 1	0	E4 h	
	para 1	1	27 h	NL=320
	para 2	1	00 h	SCN=G0
	para 3	1	10 h	TMG=1,SM=GS=0
7	GATECTRL 2	0	B7 h	
	para 1	1	75 h	VGH=14.9,VGL=-10.4
8	VCOMS setting	0	BB h	
	para 1	1	20 h	$\Delta v=0.9\text{typ}$
9	VAP/VAN signal	0	D2 h	
	para 1	1	4C h	
10	VRH set	0	C3 h	
	para 1	1	17 h	VAP=4.7+
11	Frame rate	0	C6 h	
	para 1	1	EF h	Column inversion,60Hz
12	Power control 1	0	D0 h	
	para 1	1	A4 h	
	para 2	1	A1 h	
13	Positive gamma	0	E0 h	
	para 1	1	F0 h	
	para 2	1	04 h	
	para 3	1	0B h	
	para 4	1	11 h	
	para 5	1	10 h	
	para 6	1	1B h	
	para 7	1	2F h	
	para 8	1	33 h	
	para 9	1	40 h	
	para 10	1	27 h	
	para 11	1	17 h	
	para 12	1	14 h	
	para 13	1	19 h	
	para 14	1	23 h	
	Wait 10 msec or more			



(2/2)

No.		RS	ID[7:0]	Remarks
14	Negative gamma	0	E1 h	
	para 1	1	F0 h	
	para 2	1	04 h	
	para 3	1	0B h	
	para 4	1	11 h	
	para 5	1	10 h	
	para 6	1	1B h	
	para 7	1	2F h	
	para 8	1	33 h	
	para 9	1	40 h	
	para 10	1	27 h	
	para 11	1	17 h	
	para 12	1	14 h	
	para 13	1	19 h	
	para 14	1	23 h	
	Wait 10 msec or more			
15	Equalize control	0	E9 h	
	para 1	1	08 h	
	para 2	1	08 h	
	para 3	1	00 h	
16	RGB interface control	0	B1 h	
	para 1	1	00 h	
	para 2	1	04 h	
	para 3	1	14 h	
17	RAM Control	0	B0 h	
	para 1	1	00 h	RM=0,DM=00:CPU interface
	para 2	1	E0 h / E1 h	When Data with 8bit, set "E1h".
18	CA SET	0	2A h	
	para 1	1	00 h	XS[15:8]
	para 2	1	00 h	XS[7:0]
	para 3	1	00 h	XE[15:8]
	para 4	1	EF h	XE[7:0]
19	RA SET	0	2B h	
	para 1	1	00 h	YS[15:8]
	para 2	1	00 h	YS[7:0]
	para 3	1	01 h	YE[15:8]
	para 4	1	3F h	YE[7:0]
20	GT ADJ	0	B8 h	
	para 1	1	2A h	
	para 2	1	2B h	
	para 3	1	14 h	
	para 4	1	F5 h	
21	Tearing Effect On	0	35 h	
	para 1	1	00 h	TEM = 0
22	RAMWR	0	2C h	
	data 1	1	**** h	write data
	data 2	1	**** h	write data
 h	
	data n	1	**** h	write data
	wait 10 msec or more			
23	Display ON	0	29 h	
	wait 10 msec or more			
24	Backlight ON			

△ 9.2 Sleep IN Sequence

No.		RS	ID[7:0]	Remarks
1	Backlight OFF			
2	Display OFF	0	28 h	
	Wait 10 msec or more			
3	Sleep In	0	10 h	

△ 9.3 Sleep OUT Sequence

No.		RS	ID[7:0]	Remarks
1	Sleep Out	0	11 h	
	Wait 120 msec or more			
2	Display ON	0	29 h	
	Wait 50 msec or more			
3	Backlight ON			

△ 9.4 Power OFF Sequence

No.		RS	ID[7:0]	Remarks
1	Backlight OFF			
2	Display OFF	0	28 h	
	Wait 10 msec or more			
3	Sleep In	0	10 h	
	Wait 120 msec or more			
4	RESETB High → Low			
5	VCI/IOVCC OFF			



9.5 Refresh Sequence

(1/2)

No.		RS	ID[7:0]	Remarks
1	Sleep Out	0	11 h	
	Wait 120 msec or more			
2	Memory access control	0	36 h	
	para 1	1	00 h	MX=MY=0
3	LCM Control	0	C0 h	
	para 1	1	3C h	XINV=XMV=XXM=XBGR=1
4	Pixel format	0	3A h	
	para 1	1	05 h	05h:65k,06h:262k
5	CMD2EN	0	DF h	
	para 1	1	5A h	
	para 2	1	69 h	
	para 3	1	02 h	
	para 4	1	01 h	Command2 enable
6	GATECTRL 1	0	E4 h	
	para 1	1	27 h	NL=320
	para 2	1	00 h	SCN=G0
	para 3	1	10 h	TMG=1,SM=GS=0
7	GATECTRL 2	0	B7 h	
	para 1	1	75 h	VGH=14.9,VGL=-10.4
8	VCOMS setting	0	BB h	
	para 1	1	20 h	$\Delta v=0.9\text{typ}$
9	VAP/VAN signal	0	D2 h	
	para 1	1	4C h	
10	VRH set	0	C3 h	
	para 1	1	17 h	VAP=4.7+
11	Frame rate	0	C6 h	
	para 1	1	EF h	Column inversion,60Hz
12	Power control 1	0	D0 h	
	para 1	1	A4 h	
	para 2	1	A1 h	
13	Positive gamma	0	E0 h	
	para 1	1	F0 h	
	para 2	1	04 h	
	para 3	1	0B h	
	para 4	1	11 h	
	para 5	1	10 h	
	para 6	1	1B h	
	para 7	1	2F h	
	para 8	1	33 h	
	para 9	1	40 h	
	para 10	1	27 h	
	para 11	1	17 h	
	para 12	1	14 h	
	para 13	1	19 h	
	para 14	1	23 h	
	Wait 10 msec or more			



(2/2)

No.		RS	ID[7:0]	Remarks
14	Negative gamma	0	E1 h	
	para 1	1	F0 h	
	para 2	1	04 h	
	para 3	1	0B h	
	para 4	1	11 h	
	para 5	1	10 h	
	para 6	1	1B h	
	para 7	1	2F h	
	para 8	1	33 h	
	para 9	1	40 h	
	para 10	1	27 h	
	para 11	1	17 h	
	para 12	1	14 h	
	para 13	1	19 h	
	para 14	1	23 h	
	Wait 10 msec or more			
15	Equalize control	0	E9 h	
	para 1	1	08 h	
	para 2	1	08 h	
	para 3	1	00 h	
16	RGB interface control	0	B1 h	
	para 1	1	00 h	
	para 2	1	04 h	
	para 3	1	14 h	
17	RAM Control	0	B0 h	
	para 1	1	00 h	RM=0,DM=00:CPU interface
	para 2	1	E0 h / E1 h	When Data with 8bit, set "E1h".
18	CA SET	0	2A h	
	para 1	1	00 h	XS[15:8]
	para 2	1	00 h	XS[7:0]
	para 3	1	00 h	XE[15:8]
	para 4	1	EF h	XE[7:0]
19	RA SET	0	2B h	
	para 1	1	00 h	YS[15:8]
	para 2	1	00 h	YS[7:0]
	para 3	1	01 h	YE[15:8]
	para 4	1	3F h	YE[7:0]
20	GT ADJ	0	B8 h	
	para 1	1	2A h	
	para 2	1	2B h	
	para 3	1	14 h	
	para 4	1	F5 h	
21	Tearing Effect On	0	35 h	
	para 1	1	00 h	TEM = 0
22	RAMWR	0	2C h	
	data 1	1	**** h	write data
	data 2	1	**** h	write data
 h	
	data n	1	**** h	write data
	wait 10 msec or more			
23	Display ON	0	29 h	
	wait 10 msec or more			

9.6 Power ON/OFF timing



Power Supply ON Sequence

We recommend that you supplied at the same time VCI and IOVCC.
However, there is no problem even if the supply IOVCC later than VCI.
Please release the reset from at least 10us after each power supply.

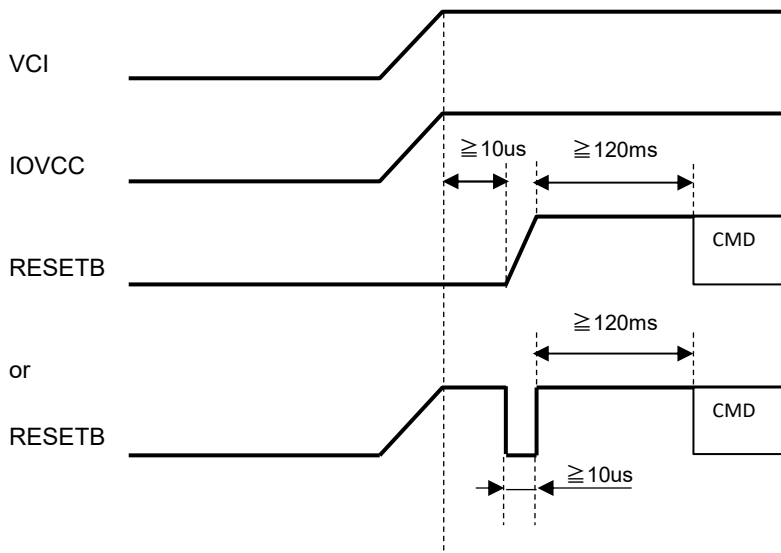

Power Supply OFF Sequence

We recommend that you removed at the same time VCI and IOVCC.
However, there is no problem even if IOVCC OFF faster than VCI .

10. LED Circuit

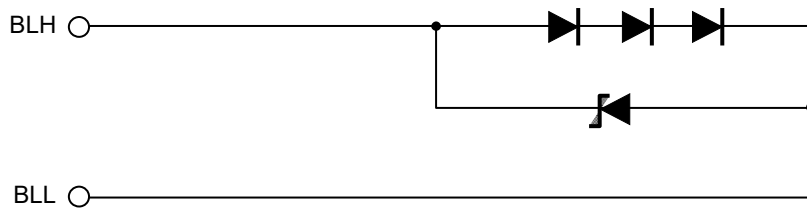

11. Touch Panel Circuit

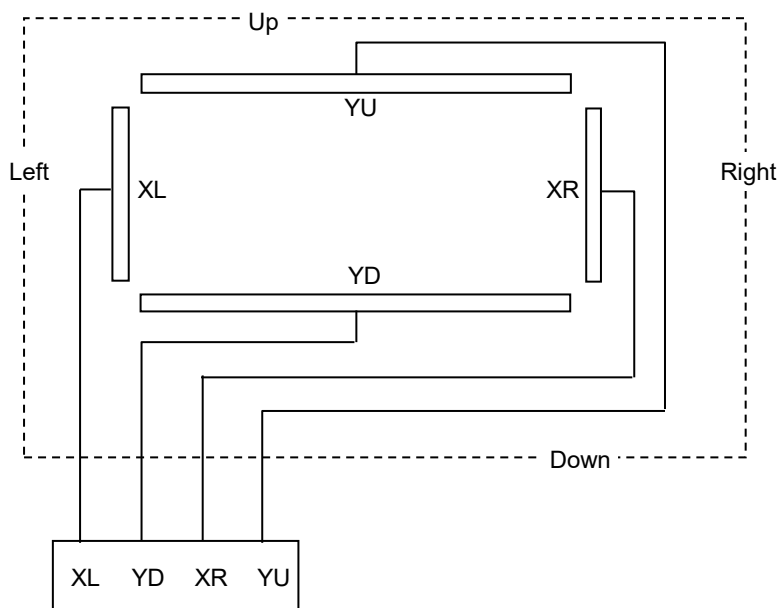

12. Characteristics

12.1 Optical Characteristics

(Measurement Condition)

Measuring instruments: CS2000 (KONICA MINOLTA), LCD7200 (OTSUKA ELECTRONICS), EZcontrastXL88 (ELDIM)

Driving condition: VCI=IOVCC=2.7V, VSS=0V, Optimized VCOMDC

Backlight: IL= 7.0 mA

Measured temperature: Ta = 25°C

Item		Symbol	Condition	MIN	TYP	MAX	Unit	Note №	Remark
Response time	Rise time	TON	[Data]= 00h ← → 3Fh	-	-	100	ms	1	
	+ Fall time	TOFF							
Contrast ratio	Backlight ON	CR	[Data]= 3Fh / 00h	400	800	-		2	
	Backlight OFF			-	2.0	-			
Viewing angle	Left	θL	[Data]= 3Fh / 00h CR ≥ 10	80	-	-	deg	3	
	Right	θR		80	-	-	deg		
	Up	φU		80	-	-	deg		
	Down	φD		80	-	-	deg		
White Chromaticity		x y	[Data]= 3Fh	White chromaticity range				4	
Center Brightness			[Data]= 3Fh	200	280	-	cd/m ²	5	
Brightness distribution			[Data]= 3Fh	70	-	-	%	6	
Burn-in				No noticeable burn-in image shall be observed after 2 hours of window pattern display.				7	

* Note number 1 to 7: Refer to the APPENDIX of "Reference Method for Measuring Optical Characteristics and Performance".

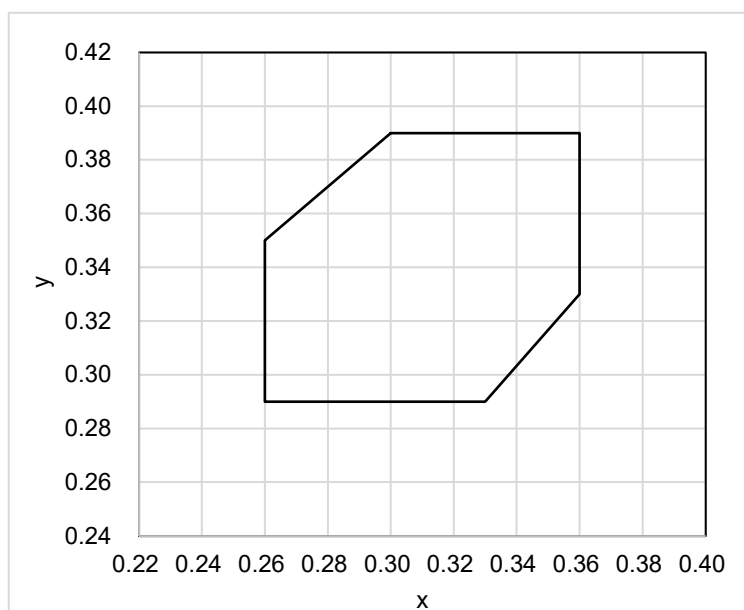

White Chromaticity Range

(White Chromaticity Range)

x	y
0.30	0.39
0.26	0.35
0.26	0.29
0.33	0.29
0.36	0.33
0.36	0.39

12.2 Temperature Characteristics

(Measurement Condition)

Measuring instruments: CS2000 (KONICA MINOLTA), LCD7200 (OTSUKA ELECTRONICS)

Driving condition: VCI=IOVCC=2.7V, VSS=0V, Optimized VCOMDC

Backlight: IL= 7.0 mA

Item		Symbol	Specification		Remark
			Ta = -20 °C	Ta = 70 °C	
Response time	Rise time + Fall time	TON + TOFF	1000 msec or less	80 msec or less	
Contrast ratio		CR	200 or more	200 or more	Backlight ON
Display Quality			No noticeable display defect or ununiformity should be observed.		

13. Criteria of Judgment

13.1 Defective Display and Screen Quality

Test Condition: Observed TFT-LCD monitor from front during operation with the following conditions

Driving Signal: Raster Patter (RGB, white, black)

Signal condition: [Data]:00h, 28h, 3Fh (3steps)

Observation distance: 30 cm

Illuminance: 200 to 350 lx

Backlight: IL=7.0mA

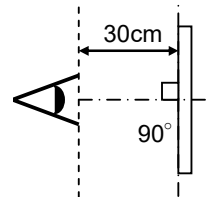

Defect item	Defect content	Criteria			
Display Quality	Line defect	Black, white or color line, 3 or more neighboring defective dots	Not exists		
	Dot defect	Uneven brightness on dot-by-dot base due to defective TFT or CF, or dust is counted as dot defect (brighter dot, darker dot)	Refer to table 1		
		High bright dot: Visible through 2% ND filter at [Data]=00h			
		Low bright dot: Visible through 5% ND filter at [Data]=00h			
	Dark dot: Appear dark through white display at [Data]=28h				
	Invisible through 5% ND filter at [Data]=00h	Acceptable			
Screen Quality	Stain	Uneven brightness (white stain, black stain etc)	Invisible through 5% ND filter at Black screen. Invisible through 1% ND filter at other screen.		
	Foreign particle	Point-like	$0.25\text{mm} < \phi$	N=0	
			$0.20\text{mm} < \phi \leq 0.25\text{mm}$	$N \leq 2$	
			$\phi \leq 0.20\text{mm}$	Acceptable	
	Liner	Liner	$3.0\text{mm} < \text{length and } 0.08\text{mm} < \text{width}$	N=0	
			$\text{length} \leq 3.0\text{mm}$ or $\text{width} \leq 0.08\text{mm}$	Acceptable	
	Flaw	Flaw on the surface of Touch Panel	$0.05\text{mm} < W$	Conform to the criteria of point-like foreign particles.	
			$0.03 < W \leq 0.05\text{mm}$	$2 < L \leq 5\text{mm}$	$N \leq 5$
				$L \leq 2\text{mm}$	Acceptable
			$W \leq 0.03\text{mm}$	Acceptable	
Others		Use boundary sample for judgment when necessary			

ϕ (mm): Average diameter = (major axis + minor axis)/2
Permissible number: N

Table1

Area	High bright dot	Low bright dot	Dark dot	Total	Criteria
A	0	2	2	3	Permissible distance between same color bright dots (includes neighboring dots): 3 mm or more Permissible distance between same color high bright dots (includes neighboring dots): 5 mm or more
B	2	4	4	5	
Total	2	4	4	5	

<Portrait model>

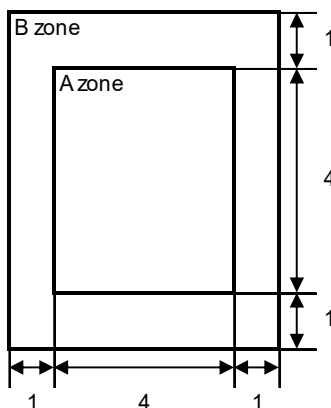

Division of A and B areas

B area: Active area

Dimensional ratio between A and B areas: 1: 4: 1
(Refer to the left figure)

A 13.2 Screen and Other Appearance

Testing conditions

Observation distance : 30 cm

Illuminance : 1200 ~ 2000 lx

Item	Criteria	Remark
Polarizer Flaw Stain Dirt Bubble Dust Dent	Ignore invisible defect when the backlight is on.	Applicable area: Active area only (Refer to the section 3.2 Outward Form)
S case	No functional defect occurs	
FPC	No functional defect occurs	

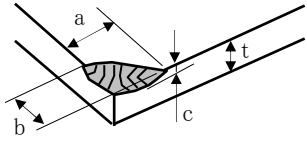
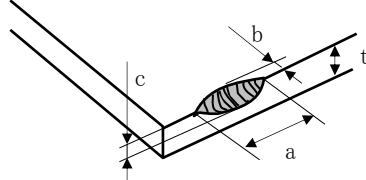
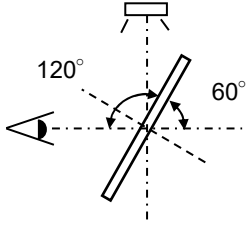
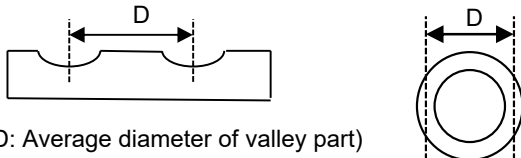
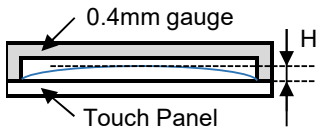
Item	Appearance	Criteria
Glass chipping	Corner area 	Unit: mm $a \leq 3$ $b \leq 3$ $c \leq t$ (t: glass thickness) $a, b \leq 0.5$ is acceptable $n \leq 2$
	Others 	Unit: mm $a \leq 5$ $b \leq 1$ $c \leq t$ (t: glass thickness) $a, b \leq 0.5$ is acceptable Maximum permissible number of chipping off on a side is 5.
	Progressive crack	None
Interference fringe	Concentric interference fringe (Test method) Observe the Panel surface from 60 degrees angle to the surface under white fluorescent lamp (Triple band fluorescent lamp) 	Average diameter : $D \leq 8\text{mm}$ is acceptable. Darkness: comply with the boundary sample
	Fisheye Film surface  (D: Average diameter of valley part)	$\Phi 0.6 \text{ mm} < D$ Ignored $\Phi 0.2 \text{ mm} < D \leq \Phi 0.6 \text{ mm}$ $N \leq 2$ $D \leq \Phi 0.2 \text{ mm}$ $N=0$
Puffiness	 0.4mm gauge Touch Panel H	$H \leq 0.4\text{mm}$ is acceptable.



14. Reliability Test

Test item		Test condition	number of failures / number of examinations
Durability test	High temperature storage	Ta = 80°C 240hrs	0 / 3
	Low temperature storage	Ta = -30°C 240hrs	0 / 3
	High temperature & high humidity storage	Ta = 60°C, RH = 90%, non condensing ※	0 / 3
	High temperature operation	Tp = 70°C 240hrs	0 / 3
	Low temperature operation	Tp = -20°C 240hrs	0 / 3
	High temperature & high humidity operation	Tp = 40°C, RH = 90%, non condensing ※	0 / 3
	Thermal shock storage	-30°C ↔ 80°C (30min / 30min) 100cycles	0 / 3
Mechanical environmental test	Electrostatic discharge test (Non operation)	Confirms to EIAJ ED-4701/300, C=200pF,R=0Ω,V=±200V Each 3 times of discharge on and power supply and other terminals.	0 / 3
	Surface discharge test (Non operation)	C=250pF, R=100Ω, V=±12kV Each 5 times of discharge in both polarities on the center of screen with the case grounded.	0 / 3
	Vibration test	Total amplitude 1.5mm, f=10~55Hz, X,Y,Z directions for each 2 hours	0 / 3
	Impact test	Use TOPPAN original jig (see next page) and make an impact with peak acceleration of 1000m/s ² for 6 msec with half sine-curve at 3 times to each X, Y, Z directions in conformance with JIS C 60068-2-27-2011.	0 / 3
Packing test	Packing vibration-proof test	Acceleration of 19.6m/s ² with frequency of 10→55→10Hz, X,Y, Zdirection for each 30 minutes.	0 / 1 packing
	Packing drop test	Drop from 75cm high. 1 time to each 6 surfaces, 3 edges, 1 corner	0 / 1 packing

Note: Ta=ambient temperature Tp=Panel temperature

※ The profile of high temperature/humidity storage and High Temperature/humidity operation (Pure water of over 10MΩ·cm shall be used.)

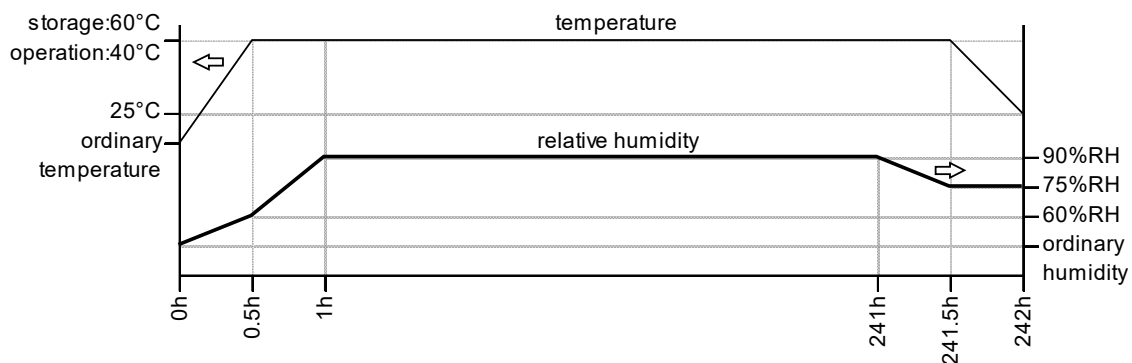
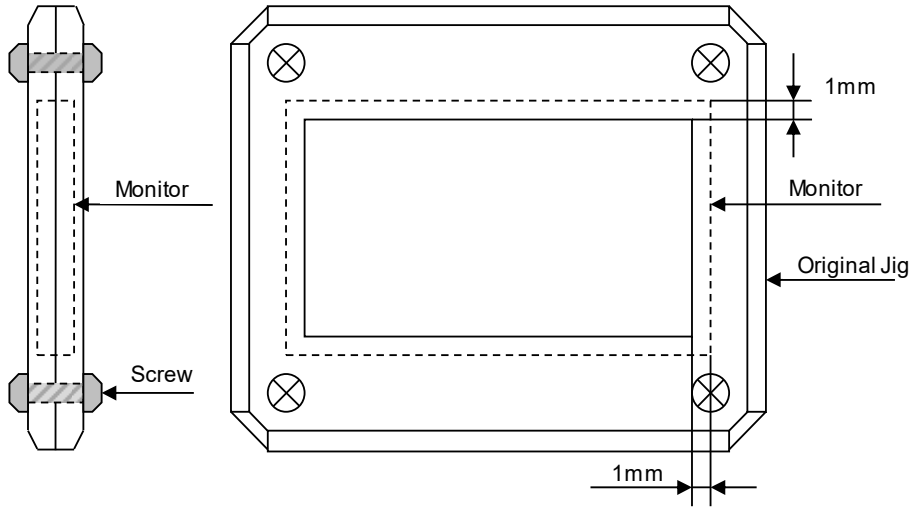

Table2. Reliability Criteria

The parameters should be measured after leaving the monitor at the ordinary temperature for 24 hours or more after the test completion.

Item	Standard	Remark
Display quality	No visible abnormality shall be seen. (Except for unevenness by PoI deterioration.)	
Contrast ratio	200 or more	Backlight ON

TOPPAN Original Jig



15. Packing Specifications

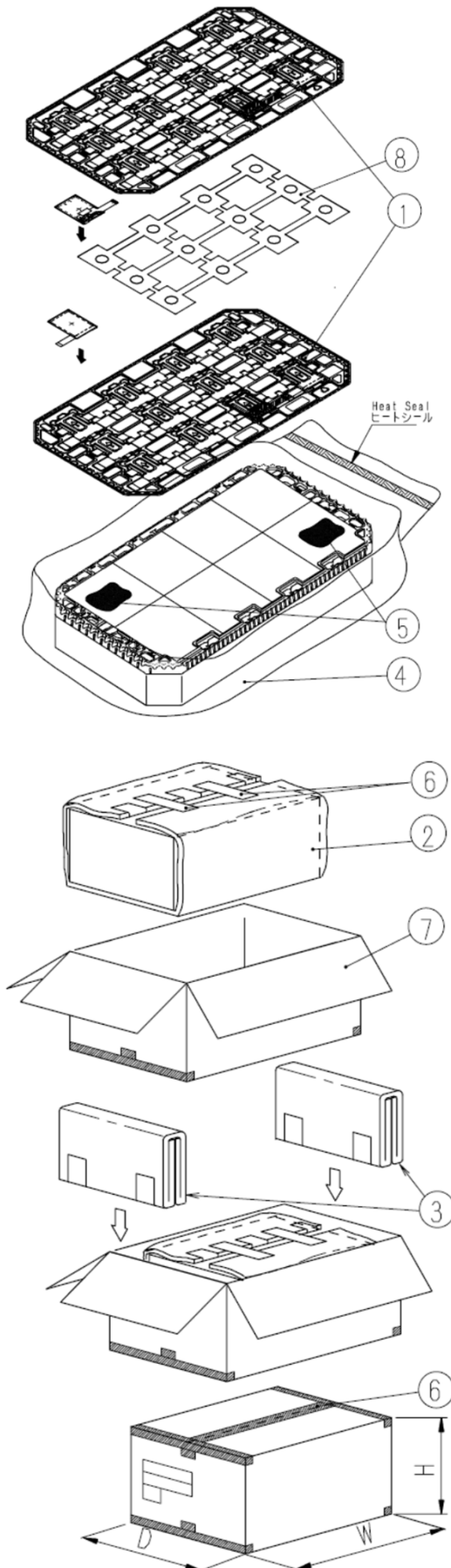

- Step 1. Each product is to be placed in one of the cut-outs of the tray with the display surface facing upward.
Foam sheet A are to be placed on the products in the tray.
Each product is to be placed in one of the cut-outs of the tray with the display surface facing downward.(24products per tray)
- Step 2. Each tray is to be piled up in same orientation and the trays be in a stack of 6.
One empty tray is to be put on the top of stack of 6 trays.
- Step 3. 2 packs of moisture absorbers are to be placed on the top tray as shown in the drawing.
Put piled trays into a sealing bag.
- Step 4. Vacuum and seal the sealing bag with the vacuum sealing machine.
- Step 5. The stack of trays in the plastic back is to be wrapped with B SHEET A.
- Step 6. The wrapped trays are placed in the carton.
- Step 7. B SHEET B are to be inserted into a outer carton with same orientation.
The outer carton is to be sealed in H-shape with packing tape as shown in the drawing.
- Step 8. The model number, quantity of products, and shipping date are to be printed on the outer carton.
If necessary, shipping labels or impression markings are to be put on the outer carton.

Remark: The return of packing materials is not required.

Packing item name		Specs., Material
①	Tray	A-PET
②	B SHEET A	Anti-static air bubble sheet
③	B SHEET B	Anti-static air bubble sheet
④	Sealing bag	
⑤	Drier	Moisture absorber
⑥	Packing tape	
⑦	Outer carton	Corrugated cardboard
⑧	FOAM SHEET A	Anti-static polyethylene

Dimension of outer carton	
D : Approx.	(337mm)
W : Approx.	(618mm)
H : Approx.	(179mm)
Quantity of products packed in one carton:	144
Gross weight : Approx.	6.0 kg

16. Handling Instruction

16.1 Cautions for Handling LCD panels

**Caution**

- (1) Do not make an impact on the LCD panel glass because it may break and you may get injured from it.
- (2) If the glass breaks, do not touch it with bare hands.
(Fragment of broken glass may stick you or you cut yourself on it.)
- (3) If you get injured, receive adequate first aid and consult a medial doctor.
- (4) Do not let liquid crystal get into your mouth.
(If the LCD panel glass breaks, try not let liquid crystal get into your mouth even toxic property of liquid crystal has not been confirmed.)
- (5) If liquid crystal adheres, rinse it out thoroughly.
(If liquid crystal adheres to your cloth or skin, wipe it off with rubbing alcohol or wash it thoroughly with soap. If liquid crystal gets into eyes, rinse it with clean water for at least 15 minutes and consult an eye doctor.)
- (6) If you scrap this products, follow a disposal standard of industrial waste that is legally valid in the community, country or territory where you reside.
- (7) Do not connect or disconnect this product while its application products is powered on.
- (8) Do not attempt to disassemble or modify this product as it is precision component.
- (9) If a part of soldering part has been exposed, and avoid contact (short-circuit) with a metallic part of the case etc. about FPC of this model, please.
Please insulate it with the insulating tape etc. if necessary.
The defective operation is caused, and there is a possibility to generation of heat and the ignition.
- (10) Since excess current protection circuit is not built in this TFT module, there is the possibility that LCD module or peripheral circuit become feverish and burned in case abnormal operation is generated.
We recommend you to add excess current protection circuit to power supply.
- (11) The end part of glass and film of touch panel has conductivity, and avoid contact (short-circuit) with electroconductive case etc.. There is a possibility of setting up a defective touch panel, and insulate it for the case suppression (cushion etc.) if necessary, please.
- (12) It may cause electrical corrosion if liquid material penetrates the edge of the touch panel, so handle with care so that no liquid adheres to the touch panel.
- (13) The devices on the FPC are damageable to electrostatic discharge, because the terminals of the devices are exposed.
Wear grounded wrist-straps and use electrostatic neutralization blowers to prevent static charge and discharge when handling the TFT monitors.
Designate an appropriate operating area, and set equipment, tools, and machines properly when handling this product.

Caution

This mark is used to indicate a precaution or an instruction which, if not correctly observed, may result in bodily injury, or material damages alone.

16.2 Precautions for Handling

- 1) Wear finger tips at incoming inspection and for handling the TFT monitors to keep display quality and keep the working area clean.
Do not touch the surface of the monitor as it is easily scratched.
- 2) Wear grounded wrist-straps and use electrostatic neutralization blowers to prevent static charge and discharge when handling the TFT monitors as the LED in this TFT monitors is damageable to electrostatic discharge.
Designate an appropriate operating area, and set equipment, tools, and machines properly when handling this product.
- 3) Avoid strong mechanical shock including knocking, hitting or dropping to the TFT monitors for protecting their glass parts.
Do not use the TFT monitors that have been experienced dropping or strong mechanical shock.
- 4) Do not use or storage the TFT monitors at high temperature and high humidity environment.
Particularly, never use or storage the TFT monitors at a location where condensation builds up.
- 5) Avoid using and storing TFT monitors at a location where they are exposed to direct sunlight or ultraviolet rays to prevent the LCD panels from deterioration by ultraviolet rays.
- 6) Do not stain or damage the contacts of the FPC cable .
FPC cable needs to be inserted until it can reach to the end of connector slot.
During insertion, make sure to keep the cable in a horizontal position to avoid an oblique insertion.
Otherwise, it may cause poor contact or deteriorate reliability of the FPC cable.
- 7) The FPC cable is a design very weak to the bend and the pull as it is fixed with the tape.
Do not bend or pull the FPC cable or carry the TFT monitor by holding the FPC cable.
- 8) Peel off the protective film on the TFT monitors during mounting process.
Refer to the section 16.5 on how to peel off the protective film.
We are not responsible for electrostatic discharge failures or other defects occur when peeling off the protective film.

16.3 Precautions for Operation

- 1) Since this TFT monitors are not equipped with light shielding for the driver IC,
do not expose the driver IC to strong lights during operation as it may cause functional failures.
- 2) In case of powering up or powering off this LCD module,
be sure to comply the sequence as instructed in this specification.
- 3) Do not plug in or out the FPC cable while power supply is switch on.
Plug the FPC cable in and out while power supply is switched off.
- 4) Do not operate the TFT monitors in the strong magnetic field. It may break the TFT monitors.
- 5) Do not display a fixed image on the screen for a long time.
Use a screen-saver or other measures to avoid a fixed image displayed on the screen for a long time.
Otherwise, it may cause burn-in image on the screen due the characteristics of liquid crystal.

16.4 Storage Condition for Shipping Cartons

(Storage environment)

- Temperature 0 to 40° C
- Humidity 60%RH or less
No-condensing occurs under low temperature with high humidity condition.
- Atmosphere No poisonous gas that can erode electronic components and/or wiring materials should be detected.
- Time period 1 year
- Unpacking To prevent damages caused by static electricity, anti-static precautionary measures (e.g. earthing, anti-static mat) should be implemented.
After unpack, keep product in the appropriate condition, otherwise bubble seal of Protective film may be printed on Polarizer.
- Maximum piling up 8 cartons (excluding the bottom)

*Conditions to storage after unpacking

(Storage environment)

- Temperature 0 to 40° C
- Humidity 60%RH or less
No-condensing occurs under low temperature with high humidity condition.
- Atmosphere No poisonous gas that can erode electronic components and/or wiring materials should be detected.
- Time period 1 year (Shelf life)
- Others Keep/ store away from direct sunlight
Storage goods on original tray made by TOPPAN.

16.5 Precautions for Peeling off the Protective film

The followings work environment and work method are recommended to prevent the TFT monitors from static damage or adhesion of dust when peeling off the protective films.

A) Work Environment

- a) Humidity: 50 to 70 %RH, Temperature 15 to 27 ° C
- b) Operators should wear conductive shoes, conductive clothes, conductive finger tips and grounded wrist-straps.
Use an electrostatic neutralization blower.
- c) Anti-static treatment should be implemented to work area's floor.
Use a room shielded against outside dust with sticky floor mat laid at the entrance to eliminate dirt.

B) Work Method

The following procedures should taken to prevent the driver ICs from charging and discharging.

- a) Use an electrostatic neutralization blower to blow air on the TFT monitors to its lower right FPC is placed at the left.
Optimize direction of the blowing air and the distance between the TFT monitors and the electrostatic neutralization blower.
- b) Peel off the tab slowly (spending more than 2 secs to complete)
by pulling it to opposite direction.

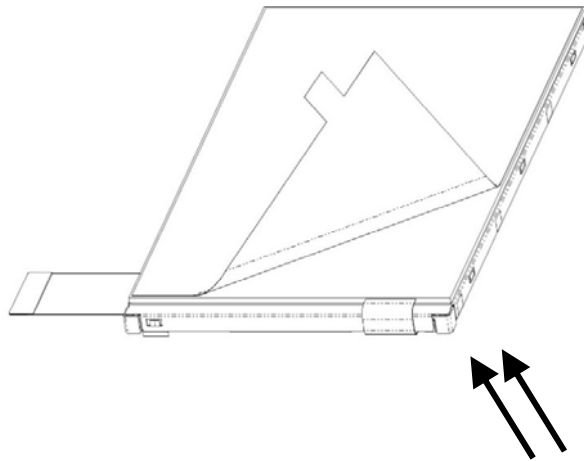

Blower wind direction
(Set an ion blower with its adequate conditions.)

16.6 Warranty

TOPPAN is only liable to defective goods which is stored and used under the condition complying with this specifications and returned within 1 (one) year.

Warranty caused by manufacturing defect shall be conducted by replacement of goods or refundment at unit price.

APPENDIX

Reference Method for Measuring Optical Characteristics and Performance

1. Measurement Condition (Backlight ON)

Measuring instruments: CS2000 (KONICA MINOLTA), LCD7200 (OTSUKA ELECTRONICS), EZcontrastXL88 (ELDIM)

Driving condition: Refer to the section "Optical Characteristics"

Measured temperature: 25°C unless specified

Measurement system: See the chart below. The luminance meter is placed on the normal line of measurement system.

Measurement point: At the center of the screen unless otherwise specified

Dark box at constant temperature

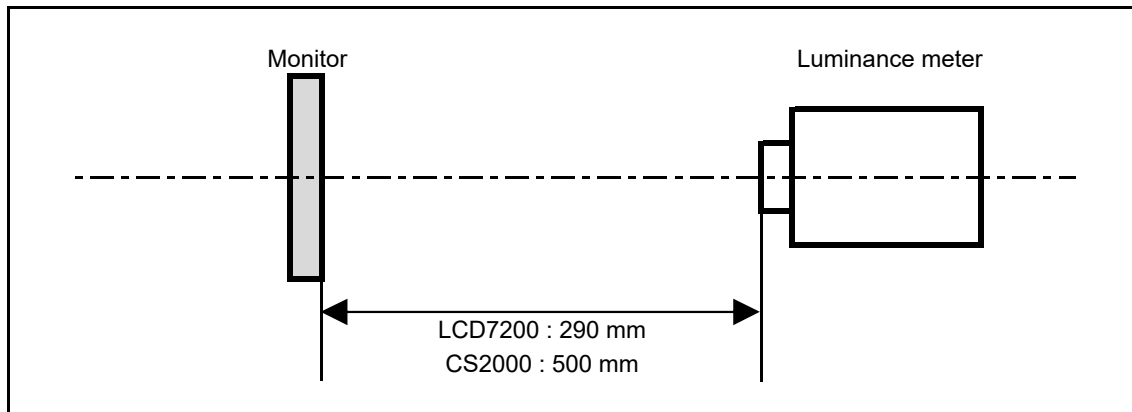

*Measurement is made after 30 minutes of lighting of the backlight.

Measurement point: At the center point of the screen

Brightness distribution: 9 points shown in the following drawing.

<Portrait model>

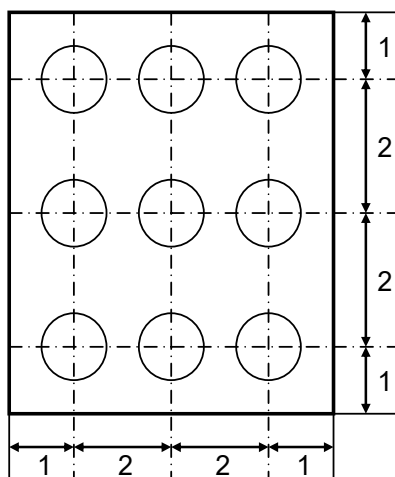

Dimensional ratio of active area

Backlight IL=7.0mA

Measurement Condition (Contrast ratio Backlight OFF only)

Measuring instruments: LCD7200(OTSUKA ELECTRONICS) , Ring Light (40,000 lx, $\phi 58$)

Driving condition: Refer to the section "Optical Characteristics"

Measured temperature: 25°C unless specified

Measurement system: See the chart below.

Measurement point: At the center of the screen unless otherwise specified

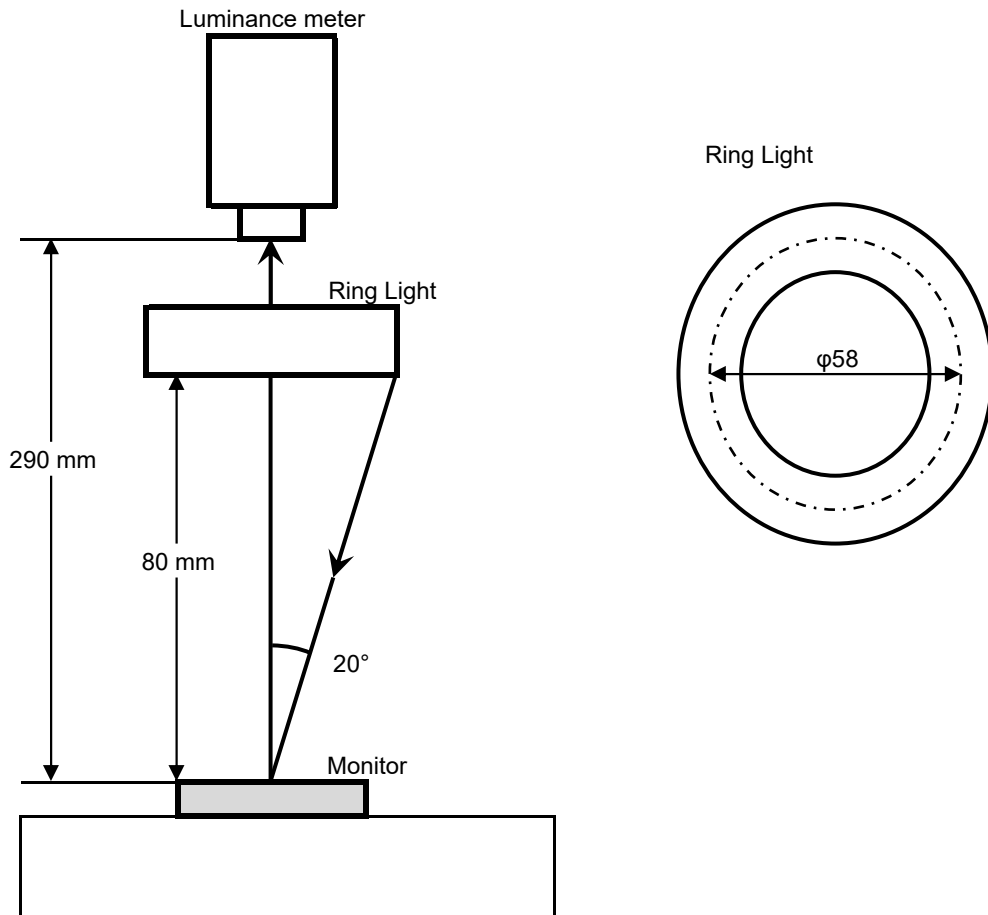

2. Test Method

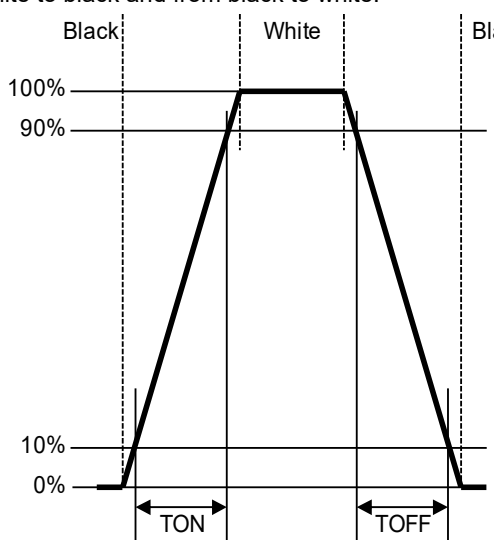
Notice	Item	Test method	Measuring instrument	Remark
1	Response time	<p>Measure output signal waveform by the luminance meter when raster of window pattern is changed from white to black and from black to white.</p> 	LCD7200	Black display [Data]=00h White display [Data]=3Fh TON Rise time TOFF Fall time
2	Contrast ratio	<p>Measure maximum luminance Y1([Data]=3Fh) and minimum luminance Y2([Data]=00h) at the center of the screen by displaying raster or window pattern. Then calculate the ratio between these two values.</p> <p>Contrast ratio = $Y1/Y2$</p> <p>Diameter of measuring point: 7.8mmφ(CS2000) Diameter of measuring point: 3mmφ(LCD7200)</p>	CS2000 LCD7200	Backlight ON Backlight OFF
3	Viewing angle Horizontalθ Verticalφ	Move the luminance meter from right to left and up and down and determine the angles where contrast ratio is 10.	EZcontrastXL88	
4	White chromaticity	<p>Measure chromaticity coordinates x and y of CIE1931 colorimetric system at [Data] = 3Fh</p> <p>Color matching function: 2°view measurement angle: 1°</p>	CS2000	
5	Center brightness	Measure the brightness at the center of the screen.	CS2000	
6	Brightness distribution	<p>(Brightness distribution) = $100 \times B/A \%$</p> <p>A : max. brightness of the 9 points B : min. brightness of the 9 points</p>	CS2000	
7	Burn-in	Visually check burn-in image on the screen after 2 hours of "window display" ([Data]=00h/3Fh).		At optimized VCOMDC

* Linearity Measurement of Touch Panel

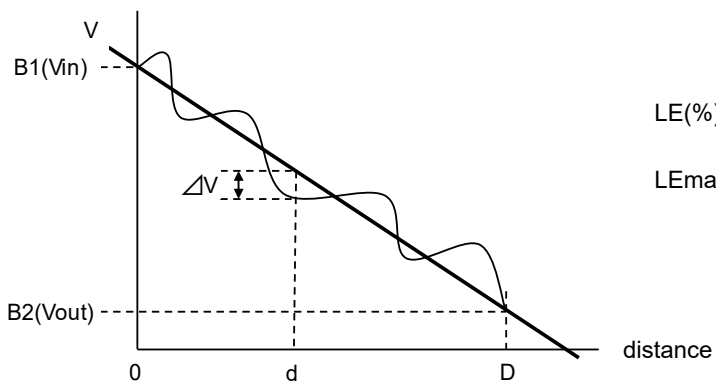

$$LE(\%) = \frac{\Delta V}{(V_{in} - V_{out})} \times 100$$

$$LE_{max}(\%) = \frac{\Delta V_{max}}{(V_{in} - V_{out})} \times 100$$

■ Cautionary instruction to handle a Touch-panel

• Cushion (between Touch Panel Chassis) Design

- 1) A cushion is required to be placed between Touch Panel and customer's chassis and there is a designated area to attach it. Attachment at area inside Input Prohibition Area must be forbidden.
If cushion was located inside Input Prohibition Area, Upper Electrode may be push constantly and which may cause the electrode breakage at the position falling on the edge of adhesive; it eventually results in Touch Panel malfunction in the future. (Please see "NG-1")
- 2) Be attention to the cushion material you use. In the case that too soft cushion was used, the cushion may protrude into Prohibition Area by being push strongly; which may result in the electrode breakage. Eventually there is a chance that the electrode breakage leads to the malfunction of Touch Panel in the future. (Please see "NG-2")
- 3) Cushion is required to be attached at the side of Customer's chassis.
Attaching a cushion at the side of Upper Electrode Film has a chance to deform the film and lead to the malfunction of Touch Panel in the future.

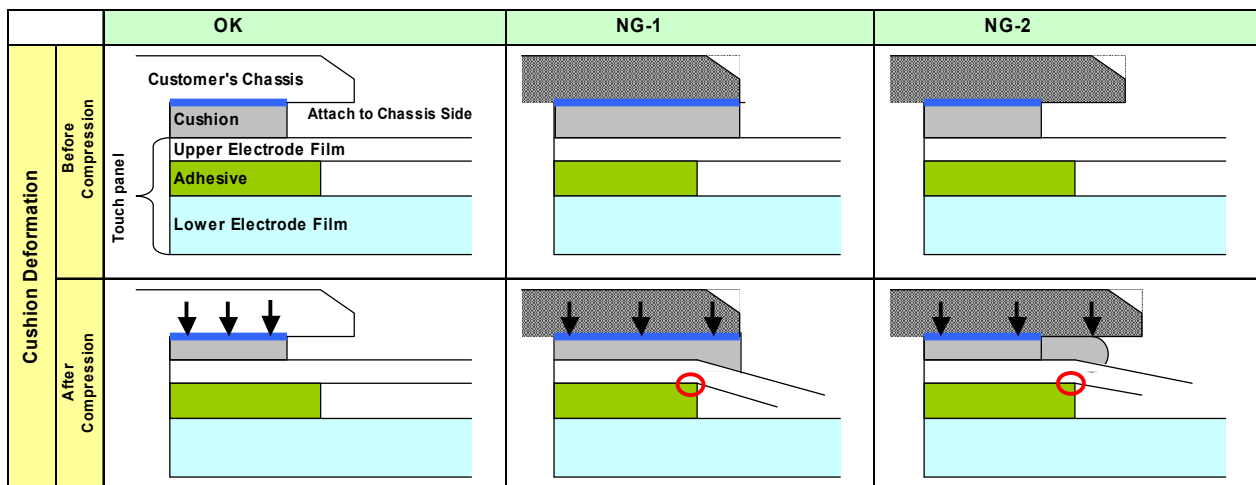

• Design Guidance of Chassis (Front Part)

- 4) Be attention to stay Input Prohibition Area away from touching and/or drawing by a stylus pens in order to avoid the electrode breakage and potential malfunction of Touch Panel. (Please see "NG-3")
We recommend customers to design chassis (front case) being able to protect Input Prohibition Area.
- 5) Clearance between customer's chassis and Touch Panel surface is certainly required in order to avoid erroneous input caused by a collision of the edge of chassis. (Please see "NG-4")
A clearance of 0.3 to 0.7mm is recommended.

• Design Guidance of Chassis (Side Part)

- 6) Upper Electrode and Lower Electrode fall on the edge of Touch Panel outline.
Redundant design having enough clearance to avoid electric short with chassis is highly recommended. (Please see "NG-5")

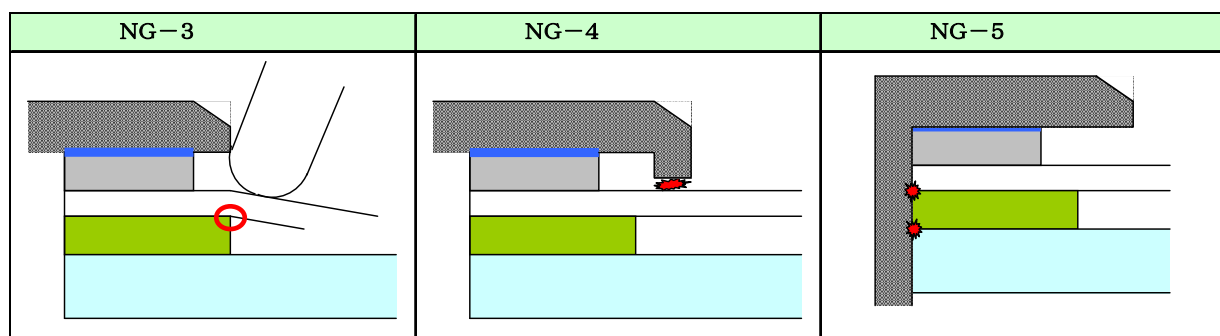

• Example of Recommended Chassis Design

Refer to "3.2 Outward Form".

- As a terminal resistance has individual specificity, calibration to align the displaying and the sensing position one each is mandatory before use.