

RECOMMENDED
PANEL CUT OUT

RoHS

IP66~68

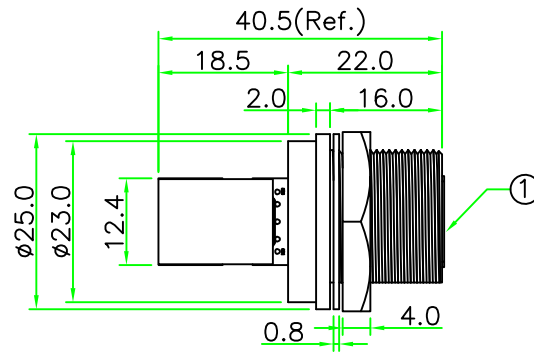

REV.	DESCRIPTION	DATE
A	ISSUE	Nov/15/2019

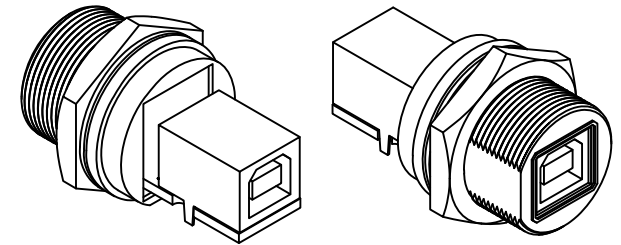

NOTES:

1. Current Rating: 1A
2. Connector Temperature Range: -25°C to 85°C
3. Contact Resistance: ≤30mΩ
4. Insulation Resistance: ≥100MΩ
5. Breakdown Voltage: ≥AC 500V/1 Minute
6. Panel Thickness Max. 6.0 mm

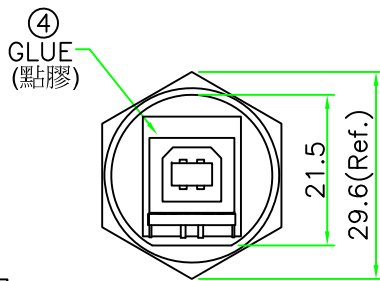

REAR VIEW
(後視圖)

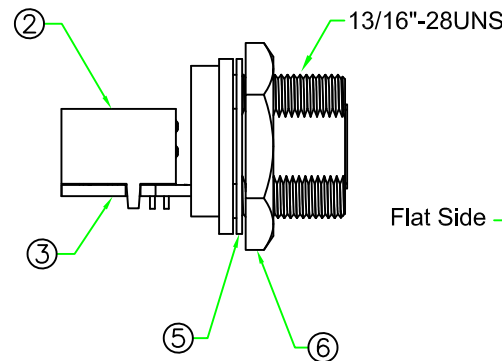

Flat Side

FRONT VIEW
(前視圖)

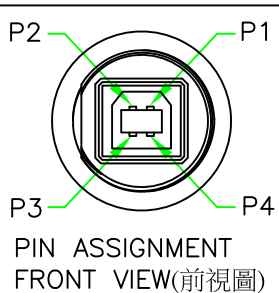

PIN ASSIGNMENT
FRONT VIEW(前視圖)

6	HEX NUT	NYLON+GF.	BLACK	1	
5	GASKET	EPDM.	BLACK	1	
4	GLUE	EPOXY.	BLACK	1	
3	PCB	FR4. Double Size, 1.6mm Thickness		1	
2	CONNECTOR	USB 2.0 B Type Female Connector.	WHITE	2	
1	BODY	USB B Type Female Connector Body. NYLON+GF.	BLACK	1	
No.	PART NAME	DESCRIPTION	COLOR	Q'TY	REMARKS

HOLIN® HTP ASIA TECHNOLOGY CO., LTD.
禾凌科技股份有限公司

	UNIT: mm	TITLE :	USB 2.0 B Type Female C Size Screw Type Circular Flange Panel With Right Angle USB 2.0 B Type Female
SCALE	1:1	P/N:	USB2BC-P3CSJ
UNLESS OTHERWISE SPECIFIED TOLERANCES: .x ±1.0 .xx ± 0.5 .xxx± 0.25 ANGLE ± 1°		DWG.NO:	USB2BC-P3CSJ
REV.	SHEET		
A	1/1		