

Specifications for
Blanview TFT-LCD Monitor
(3.5" QVGA 320 x 240 x RGB Landscape)

Version 1.0

(Please be sure to check the specifications latest version.)

MODEL COM35H3R16ULC

Customer's Approval

Signature :

Name :

Section :

Title :

Date :

ORTUSTECH



TOPPAN INC.
Electronics Division
Technological Development Department III

Approved by

S. Epuchi

Checked by

J. Matsuzaki

Prepared by

M. Tojo

Version History

Ver.	Date	Page	Description
0.0	Oct.13,2022	-	- Tentative issue
0.1 △ x5	Dec.13,2022	P.3	Contents
		Add	9.1 Driving Circuit Example
		P.10	4. Pin Assignment
		Delete	Function
		P.20-22	9. Circuit
		Add	9.1 Driving Circuit Example
		Correct	Contents number (9.2. LED Circuit)
0.2 △ x1	Apr.28,2023	P.8	3.2 Outward Form
		Change	FPC shape
1.0 △ x18	Sep.12,2023	-	- First issue
		P.1	Cover
		Change	Department name
		P.5	2.2 Display Method
		Add	NTSC ratio
		P.7	3.1 Dimensions
		Add	Surface hardness of the polarizer / Weight
		P.11	4. Pin Assignment
		Delete	Error delete
		P.12	5. Absolute Maximum Rating
		Add	Rating
		Delete	Condition
		Add	6. Recommended Operating Conditions
		Add	Note 2
		P.13	7.1.1 Display Module
		Add	Rating
		Add	7.1.2 Backlight
		Add	BL current / Rating
		P.19	8.2 Standby / Power Off Sequence
		Correct	STBY signal
		P.23	10.1 Optical Characteristics
		Add	BL current / Rating / White Chromaticity Range
		P.24	10.2 Temperature Characteristics
		Add	BL current / Specification
		P.25	11.1 Defective Display and Screen Quality
		Add	Signal condition / BL current
		Correct	Note
P.27	12. Reliability Test		
Add	number of failures /number of examinations		
Add	Applied voltage (Surface discharge test)		
P.29	13. Packing Specifications		
Add	Packing Specifications		
P.32	14.4 Storage Condition for Shipping Cartons		
Add	Maximum piling up		
P.33	14.5 Precautions for Peeling off the Protective film		
Add	Work Method		
P.34	APPENDIX (1. Measurement Condition (Backlight ON))		
Add	BL current		
P.35	APPENDIX (Measurement Condition (Contrast ratio Backlight OFF only))		
Add	Measurement Condition		

Contents

1. Application	4
2. Outline Specifications		
2.1 Features of the Product	5
2.2 Display Method	5
3. Dimensions and Shape		
3.1 Dimensions	7
3.2 Outward Form	8
3.3 Serial № print (S-print)	9
4. Pin Assignment	10
5. Absolute Maximum Rating	12
6. Recommended Operating Conditions	12
7. Electrical Characteristics		
7.1 DC Characteristics	13
7.2 AC Characteristics	14
7.3 Input Timing Characteristics	16
7.4 Driving Timing Chart	17
7.5 Example of Driving Timing Chart	18
8. Description of Operation		
8.1 Power On Sequence	19
8.2 Standby / Power Off Sequence	19
9. Circuit		
9.1 Driving Circuit Example	20
9.2 LED Circuit	22
10. Characteristics		
10.1 Optical Characteristics	23
10.2 Temperature Characteristics	24
11. Criteria of Judgment		
11.1 Defective Display and Screen Quality	25
11.2 Screen and Other Appearance	26
12. Reliability Test	27
13. Packing Specifications	29
14. Handling Instruction		
14.1 Cautions for Handling LCD panels	30
14.2 Precautions for Handling	31
14.3 Precautions for Operation	31
14.4 Storage Condition for Shipping Cartons	32
14.5 Precautions for Peeling off the Protective film	33
14.6 Warranty	33
APPENDIX	34

1. Application

This Specification is applicable to 87.9 mm (3.5 inch) Blanview TFT-LCD monitor for non-military use.

- ◎ TOPPAN makes no warranty or assume no liability that use of this Product and/or any information including drawings in this Specification by Purchaser is not infringing any patent or other intellectual property rights owned by third parties, and TOPPAN shall not grant to Purchaser any right to use any patent or other intellectual property rights owned by third parties. Since this Specification contains TOPPAN's confidential information and copy right, Purchaser shall use them with high degree of care to prevent any unauthorized use, disclosure, duplication, publication or dissemination of TOPPAN's confidential information and copy right.
- ◎ If Purchaser intends to use this Products for an application which requires higher level of reliability and/or safety in functionality and/or accuracy such as transport equipment (aircraft, train, automobile, etc.), disaster-prevention/security equipment or various safety equipment, Purchaser shall consult TOPPAN on such use in advance.
- ◎ This Product shall not be used for application which requires extremely higher level of reliability and/or safety such as aerospace equipment, telecommunication equipment for trunk lines, control equipment for nuclear facilities or life-support medical equipment.
- ◎ It must be noted as an mechanical design manner, especial attention in housing design to prevent arcuation/flexure caused by stress to the LCD module shall be considered.
- ◎ TOPPAN assumes no liability for any damage resulting from misuse, abuse, and/or miss-operation of the Product deviating from the operating conditions and precautions described in the Specification.
- ◎ It shall be mutually conferred if nonconforming defect which result from unspecified cause in this specification arises.
- ◎ If any issue arises as to information provided in this Specification or any other information, TOPPAN and Purchaser shall discuss them in good faith and seek solution.
- ◎ TOPPAN assumes no liability for defects such as electrostatic discharge failure occurred during peeling off the protective film or Purchaser's assembly process.
- ◎ This Product is compatible for RoHS(2.0) directive.

Object substance	Maximum content [ppm]
Cadmium and its compound	100
Hexavalent Chromium Compound	1000
Lead & Lead compound	1000
Mercury & Mercury compound	1000
Polybrominated biphenyl series (PBB series)	1000
Polybrominated biphenyl ether series (PBDE series)	1000
Bis(2-ethylhexyl)phthalate series(DEHP series)	1000
Butyl benzyl phthalate series(BBP series)	1000
Dibutyl phthalate series(DBP series)	1000
Diisobutyl phthalate series(DIBP series)	1000

2. Outline Specifications

2.1 Features of the Product

- 3.5 inch diagonal display, 320 [H] x 240RGB [V] dots.
- 8-bit 16,777,216 color display capability.
- 3.0V voltage single power source.
- Timing generator [TG], Counter-electrode driving circuitry, Built-in power supply circuit.
- Power save (Standby) mode capable.
- Long life & High bright white LED back-light.
- Blanview TFT-LCD, improved outdoor readability.

	Indoor		Outdoor	
	Readability	Power Efficiency (Battery Life)	Readability	Power Efficiency (Battery Life)
Transmissive	Good	Good	Fair	Poor
Transflective	Fair	Poor	Good	Good
Blanview	Good	Good	Good	Good

△ 2.2 Display Method

Items	Specifications	Remarks
Display type	VA type 16,777,216 colors. Blanview, Normally black.	
Driving method	a-Si TFT Active matrix. Line-scanning, Non-interlace.	
Dot arrangement	RGB horizontal stripe arrangement.	Refer to "Dot arrangement"
Signal input method	8-bit RGB, parallel input.	
NTSC ratio	50%	
Backlight type	Long life & High bright white LED.	

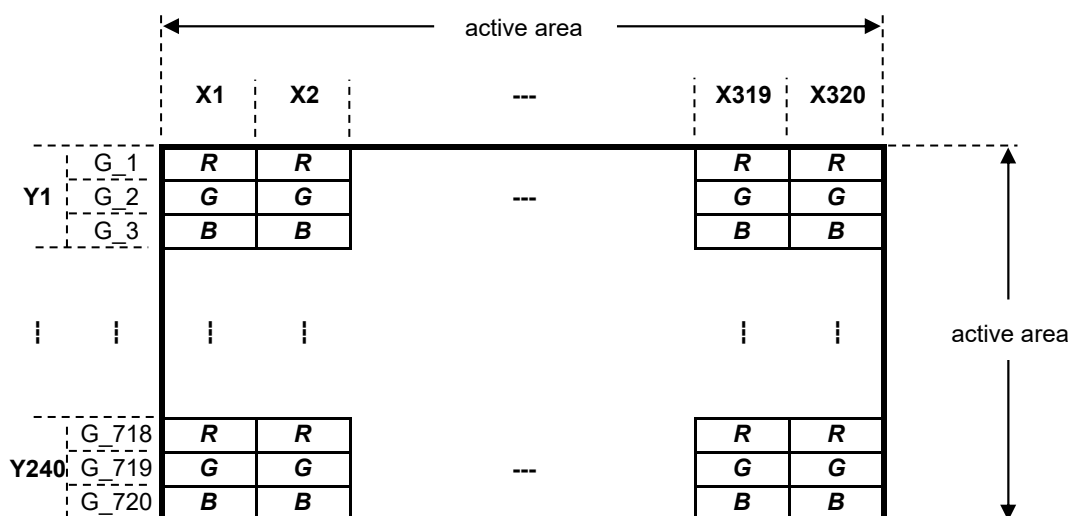

Dot arrangement (FPC cable placed downside)

<Features of Blanview>

- Backlight power consumption required to assure visibility.

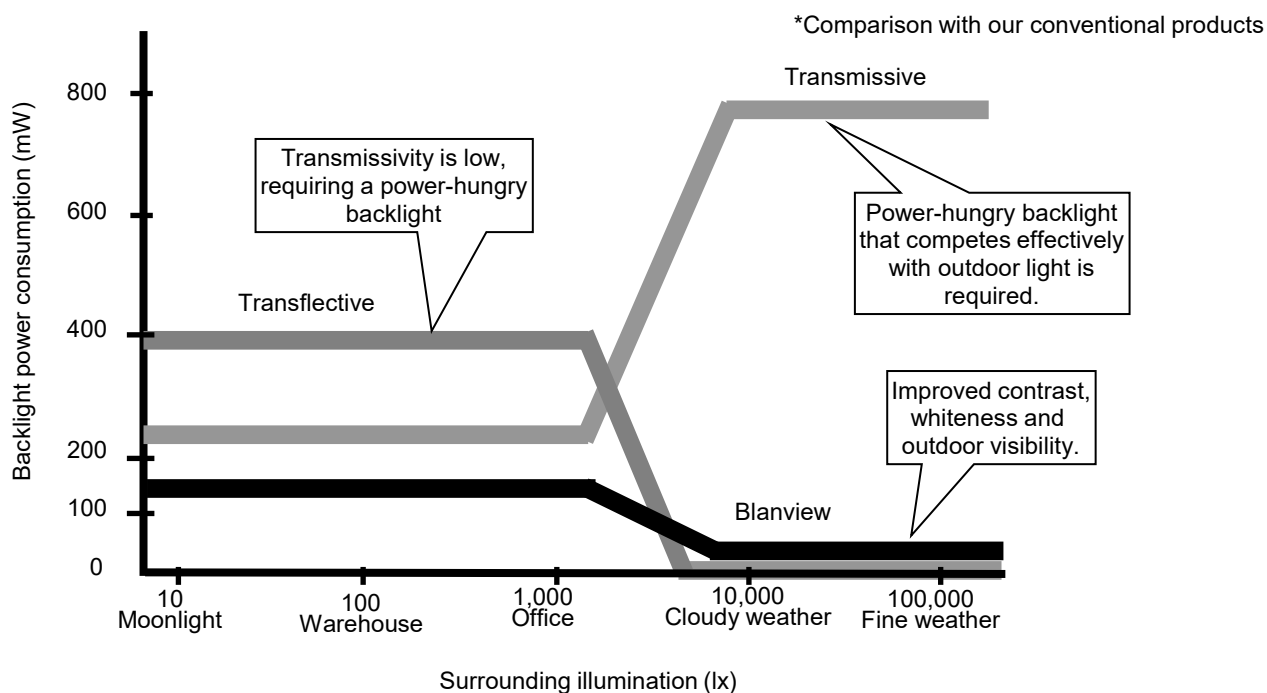

- Contrast characteristics under 100,000lx. (same condition as direct sunlight.)

With better contrast (higher contrast ratio), Blanview TFT-LCD has the best outdoor readability in three different types of TFT-LCD.

Below chart shows contrast value against panel surface brightness. (Horizontal: Panel surface brightness/ Vertical: Contrast value) LCD panel has enough outdoor readability above our Standard line. (TOPPAN criteria)

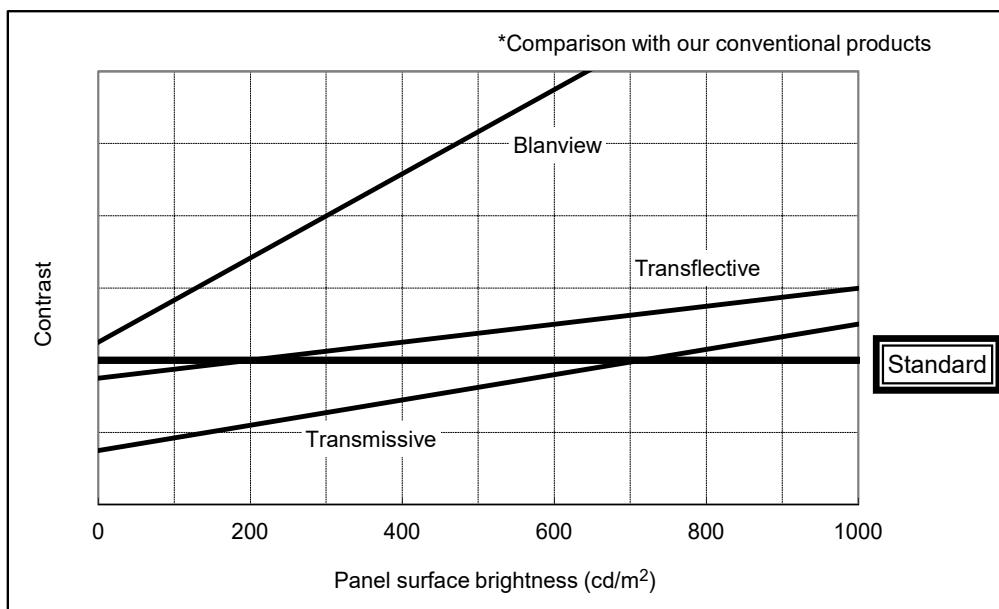

3. Dimensions and Shape

 3.1 Dimensions

Items	Specifications	Unit	Remarks
Outline dimensions	76.90[H] × 63.90[V] × 3.13[D]	mm	Exclude FPC cable
Active area	70.32[H] × 52.74[V]	mm	87.9mm diagonal
Number of dots	320[H] × 720[V]	dot	
Dot pitch	219.75[H] × 73.25[V]	um	
Surface hardness of the polarizer	2	H	Load: 4.90N
Weight	32	g	Include FPC cable

3.2 Outward Form

EC No.	REV. No.	REVISE	DATE (Y:M:D)	APPROVED	CHECKED	PREPARED
	A x 1	FPC形状変更	23:04:19	木下	加藤	前田

(8/36)
22TLM077
Issue: Sep. 12, 2023

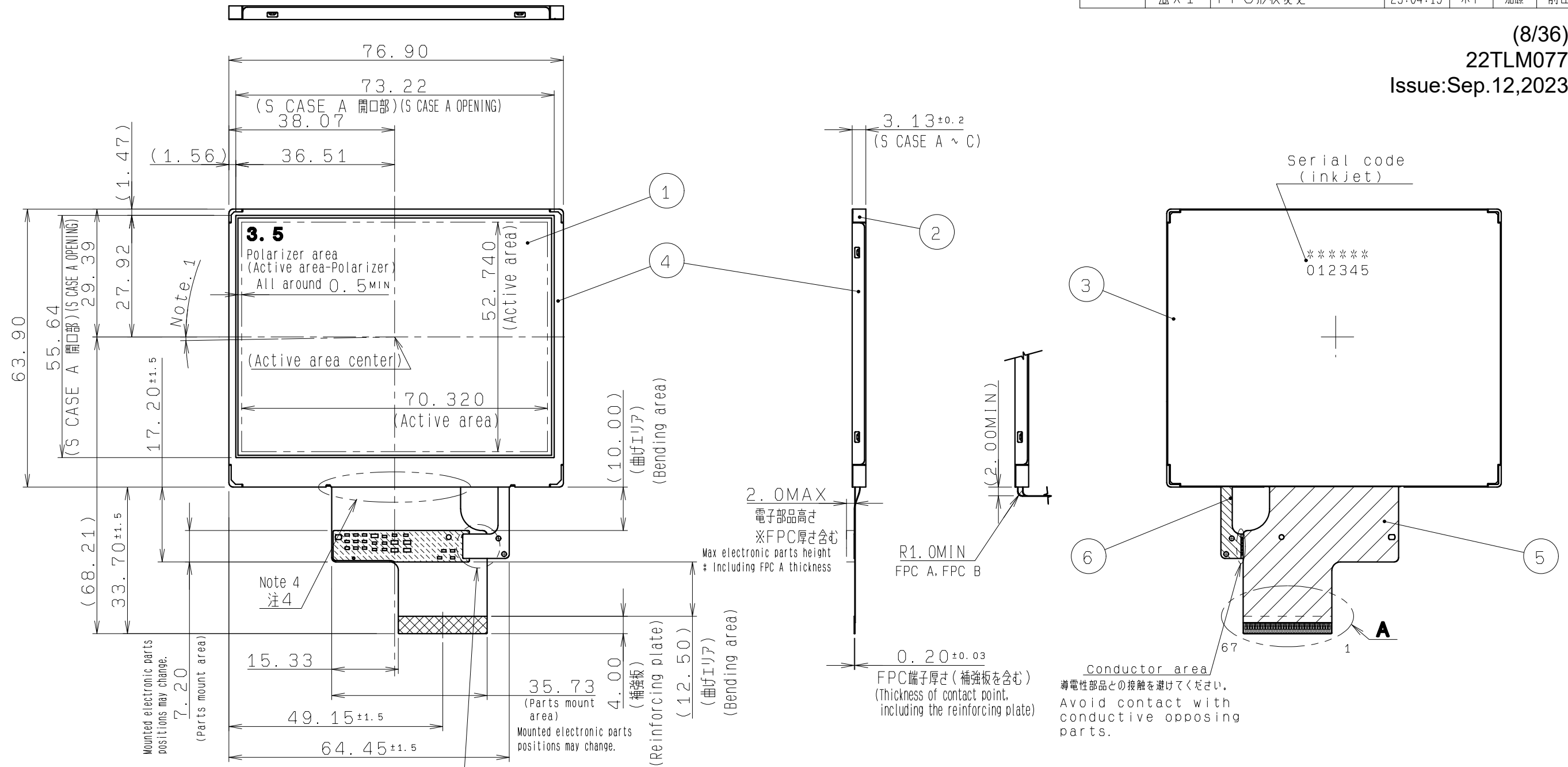

※LED FPCとLCD FPCの接合部を強く押さないでください。
強く押すと表示に不具合が生じる可能性があります。
※Please don't push LED FPC&LCD FPC bonding area strongly.
There is a possibility that trouble occurs in display when strongly pushing.

- Note 1. Angular deviation of LCD cell from the TFT-LCD monitor's reference axis shall be less than $[\pm 40']$.
注1. TFT PANELの角度 α は、モニター基準軸に対し $[\pm 40']$ 以下とする。
- Note 2. Recommended FPC connectors
HIROSE, part number : FH26G-67S-0.3SHBW(05) (Lower contact)
2. FPCの推奨コネクタの規格を下記に示す。
ヒロセ電機 : FH26G-67S-0.3SHBW(05) (下接点)
- Note 3. Protective film is affixed on front surface of the screen.
Location tolerance of the protective film shall be ± 1.5 mm to the polarizing film.
3. 保護膜が表面側に貼られます。
表面側保護膜貼付け位置は偏光板に対して $[\pm 1.5]$ とする。
- Note 4. Exercise care not to apply any forces to the FPC holder of the S case A.
4. S CASE AのFPC押さえ部先端には負荷の掛からないよう注意願います。

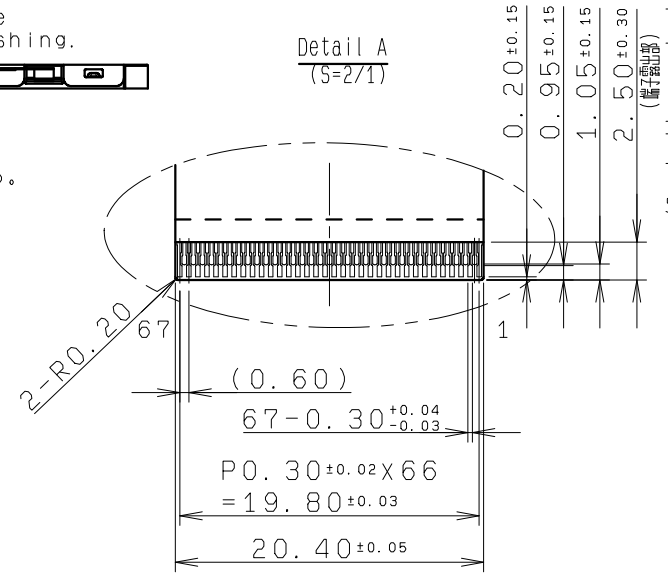

LED FPC	6			
LCD FPC	5			
S CASE A	4		SUS(t=0.15)	
S CASE C	3		SUS(t=0.2)	
Frame	2		PC	
TFT-LCD PANEL	1		Glass substrate thickness=0.5t	
PART NAME	ITEM	PART CODE	MODEL NUMBER	REMARK

APPROVED 木下	GENERAL TOLERANCE ± 0.5	SCALE 1/1(2/1)	UNIT mm	TOPPAN TOPPAN INC. DO NOT DUPLICATE, CONFIDENTIAL AND PROPRIETARY	
CHECKED 加藤	ISSUE (Y:M:D) 23:04:18	MODEL COM35H3R16U**			
CHECKED	NAME	OUTLINE-D3R16		DRAWING No. RJD603957D301	
DESIGN 前田創				REV. /	SHEET /
DRAW 前田創				ASS'Y	

3.3 Serial № print (S-print)

3.3.1 Display Items

S-print indicates the least significant digit of manufacture year (1digit), manufacture month with below alphabet (1letter), model code (5characters), serial number (6digits).

* Contents of Display

*	*	*****	*****
-	-	-----	-----
a	b	c	d

Contents of display				
a	The least significant digit of manufacture year			
b	Manufacture month	Jan-A Feb-B Mar-C Apr-D	May-E Jun-F Jul-G Aug-H	Sep-I Oct-J Nov-K Dec-L
c	Model code	35RZC (Made in Japan) 35SAC (Made in Malaysia)		
d	Serial number			

* Example of indication of Serial № print (S-print)

- Made in Japan

2L35RZC000125

means "manufactured in December 2022, 3.5" RZ type, C specifications, serial number 000125"

- Made in Malaysia

2L35SAC000125

means "manufactured in December 2022, 3.5" SA type, C specifications, serial number 000125"

3.3.2 Location of Serial № print (S-print)

Refer to 3.2 "Outward Form".

3.3.3 Others

Please note that it is likely to disappear with an organic solvent about the Serial print.

4. Pin Assignment

No.	Symbol	Function
1	NC	OPEN.
2	D27	Display data(B). 00h: Black D20:LSB D27:MSB
3	D26	
4	D25	
5	D24	
6	D23	
7	D22	
8	D21	
9	D20	
10	D17	
11	D16	
12	D15	
13	D14	
14	D13	
15	D12	
16	D11	
17	D10	
18	D07	Display data(R). 00h: Black D00:LSB D07:MSB
19	D06	
20	D05	
21	D04	
22	D03	
23	D02	
24	D01	
25	D00	
26	NC	OPEN.
27	STBY	STBY:Standby signal. (Lo:Normal operation, Hi:Standby operation)
28	DE	DE:Input data effective signal. (Hi: active)
29	REV	REV:Right/Left & Up/Down Display reverse. (Lo:Normal Display,Hi:Reverse Display)
30	VSYNC	Vertical sync signal input.(negative polarity)
31	HSYNC	Horizontal sync signal input.(negative polarity)
32	CLK	Clock input for display. (Latching data at the falling edge)
33	VSS	GND.
34	MODE	Connect to VDD or GND.
35	POCB	Power on clear. (Lo: active)
36	NC	OPEN.
37	NC	OPEN.
38	NC	OPEN.
39	NC	OPEN.
40	NC	OPEN.
41	NC	OPEN.
42	NC	OPEN.
43	NC	OPEN.
44	NC	OPEN.
45	VDD	Power supply input.

No.	Symbol	Function
46	NC	OPEN.
47	NC	OPEN.
48	VSS	GND.
49	VSS	GND.
50	VSS	GND.
51	NC	OPEN.
52	NC	OPEN.
53	NC	OPEN.
54	NC	OPEN.
55	NC	OPEN.
56	NC	OPEN.
57	NC	OPEN.
58	NC	OPEN.
59	NC	OPEN.
60	NC	OPEN.
61	NC	OPEN.
62	BLL2	LED drive power source 2. (Cathode side)
63	BLH2	LED drive power source 2. (Anode side)
64	NC	OPEN.
65	NC	OPEN.
66	BLH1	LED drive power source 1. (Anode side)
67	BLL1	LED drive power source 1. (Cathode side)



- Recommended connector : HIROSE ELECTRIC CO.,LTD. FH26 series [FH26G-67S-0.3SHBW(05)]
- Please refer to the section "3.2 Outward Form" for terminal order.
- Since FPC cable has gold plated terminals, gilt finish contact shoe connector is recommended.



5. Absolute Maximum Rating

VSS=0V

Item	Symbol	Condition	Rating		Unit	Applicable terminal
			MIN	MAX		
Supply voltage	VDD		-0.3	5.0	V	VDD
Input voltage for logic	VI		-0.3	VDD+0.3	V	POCB,CLK,VSYNC,HSYNC, D[27:20],D[17:10],D[07:00], MODE,DE,STBY,REV
LED forward current	IL	Ta = 25 °C	--	35	mA	BLH1 - BLL1
		Ta = 70 °C	--	15		BLH2 - BLL2
Storage temperature range	Tstg		-30	80	°C	
Storage humidity range	Hstg	Non condensing in an environmental moisture at or less than 40 °C90%RH.				

Note: Please set "Power-on" and "Power-off" sequences in accordance with the "Power On Sequence" described later.



6. Recommended Operating Conditions

VSS=0V

Item	Symbol	Condition	Rating			Unit	Applicable terminal
			MIN	TYP	MAX		
Supply voltage	VDD		2.7	3.0	3.6	V	VDD
Input voltage for logic	VI	VDD=2.7~3.6V	0	--	VDD	V	POCB,CLK,VSYNC, HSYNC,D[27:20], D[17:10],D[07:00], MODE,STBY,DE,REV
Operational temperature range	Top	Note1,2	-20	25	70	°C	Panel surface temperature
Operating humidity range	Hop	Ta ≤ 40 °C	20	--	85	%	
		Ta > 40 °C	Non condensing in an environmental moisture at or less than 40 °C85%RH.				

Note 1: This monitor is operatable in this temperature range. With regard to optical characteristics, refer to Item 10."Characteristics".

Note 2: Acceptable Forward Current to LED is up to 15mA, when Ta=+70 °C.

Do not exceed Allowable Forward Current shown on the chart below.

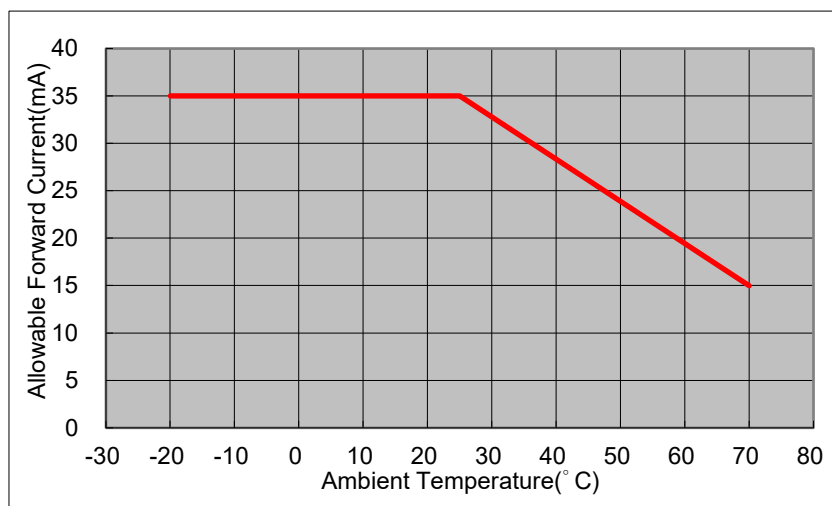

7. Electrical Characteristics

7.1 DC Characteristics

 7.1.1 Display Module

(Unless otherwise noted, Ta=25°C, VDD=3.0V, VSS=0V)

Item	Symbol	Condition	Rating			Unit	Applicable terminal
			MIN	TYP	MAX		
Input voltage for logic	VIH	VDD=2.7 to 3.6V	0.7×VDD	--	VDD	V	CLK, VSYNC, HSYNC, DE, D[27:20], D[17:10], D[07:00], POCB, STBY, REV
	VIL		0	--	0.3×VDD	V	
Pull up resister value	Rpu		29	30	31	kΩ	POCB Note
Operating Current	IDD	Input Timing = TYP Color bar display	--	20	40	mA	VDD
Standby Current	IDDs	Other input with constant voltage.	--	100	155	uA	VDD

Note: Even if the POCB terminal is not directly controlled, it operates as the Power-on-clear by connecting a 1uF external capacitor.

 7.1.2 Backlight

Item	Symbol	Condition	Rating			Unit	Applicable terminal
			MIN	TYP	MAX		
Forward current	IL25	Ta=25°C	--	8.1	35.0	mA	BLH1 – BLL1 BLH2 – BLL2
	IL70	Ta=70°C	--	--	15.0	mA	
Forward voltage	VL	Ta=25°C, IL=8.1mA	--	8.0	8.3	V	
Estimated Life of LED	LL	Ta=25°C, IL=8.1mA Note	--	50,000	--	hrs	

Note: - The lifetime of the LED is defined as a period till the brightness of the LED decreases to the half of its initial value.
 - This figure is given as a reference purpose only, and not as a guarantee.
 - This figure is estimated for an LED operating alone.
 As the performance of an LED may differ when assembled as a monitor.
 - Estimated lifetime could vary on a different temperature and usually higher temperature could reduce the life significantly.

7.2 AC Characteristics

(Unless otherwise noted, $T_a=25^\circ\text{C}$, $V_{DD}=3.0\text{V}$, $V_{SS}=0\text{V}$)

Item	Symbol	Condition	Rating			Unit	Applicable terminal
			MIN	TYP	MAX		
CLK Low period	tw1L	0.3×VDD or less	26.4	--	--	ns	CLK
CLK High period	tw1H	0.7×VDD or more	26.4	--	--	ns	
Setup time	tsp		10	--	--	ns	CLK, HSYNC, VSYNC, D[27:20], D[17:10], D[07:00], DE
Hold time	thd		16	--	--	ns	
CLK rising time	tr		--	--	10	ns	CLK
CLK falling time	tf		--	--	10	ns	
CLK frequency	fCLK		--	6.75	9.0	MHz	

Switching Waveform Characteristics

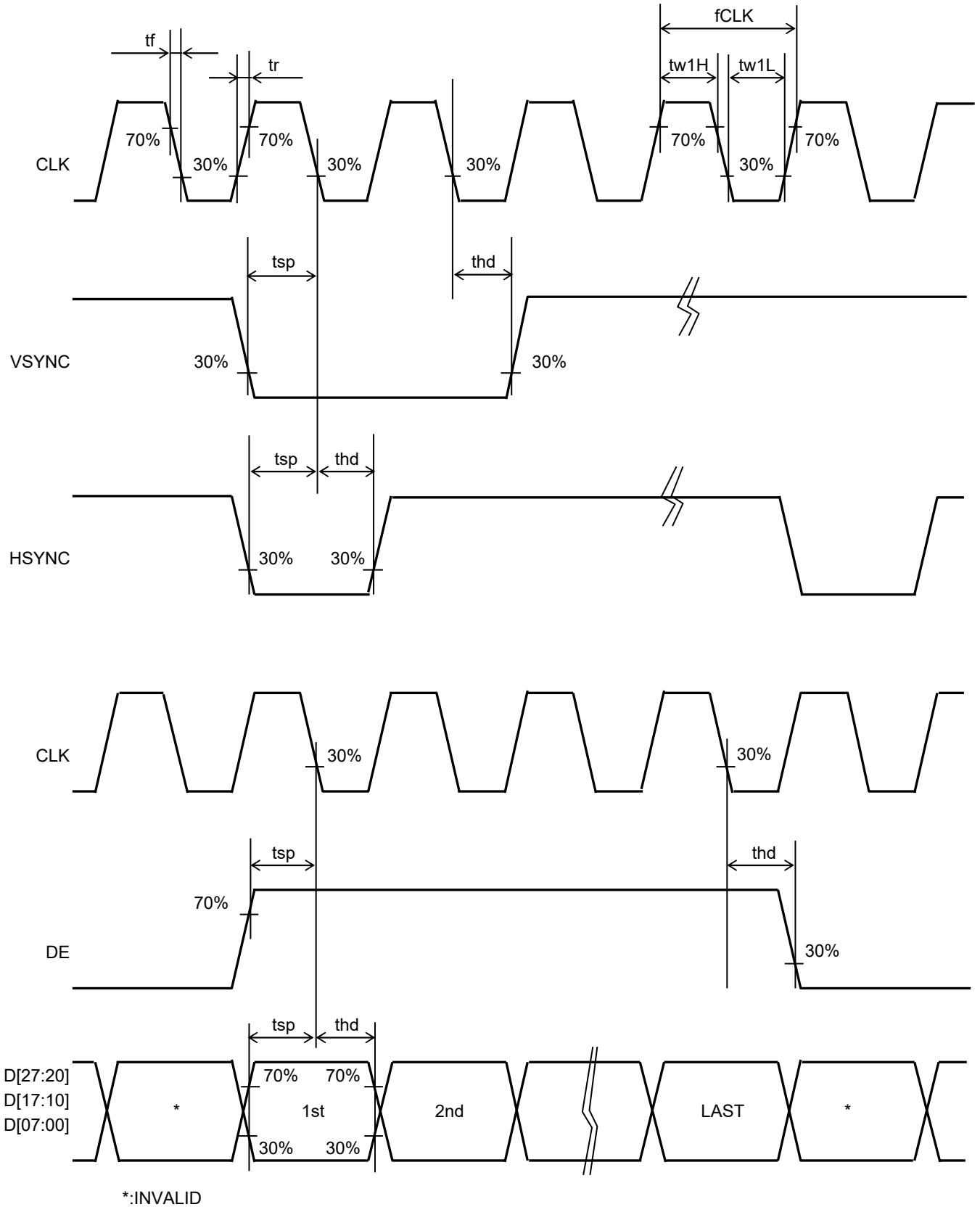

7.3 Input Timing Characteristics

(Unless otherwise noted, Ta=25 °C, VDD=3.0V, VSS=0V)

Item	Symbol	Rating			Unit	Applicable terminal
		MIN	TYP	MAX		
CLK frequency	fCLK	--	6.75	9.0	MHz	CLK
VSYNC frequency	Note fVSYNC	54	60	66	Hz	VSYNC
VSYNC signal cycle time	tv	245	262	291	H	VSYNC,HSYNC
VSYNC pulse width	tw2H	1	3	--	H	
Vertical back porch	tvb	tw2H + 2	6	21	H	
Vertical front porch	tvf	2	16	30	H	
Vertical display period	tvdp	240			H	
HSYNC frequency	fHSYNC	15.73			kHz	HSYNC
HSYNC signal cycle time	th	390	429	574	CLK	HSYNC,CLK
HSYNC pulse width	tw3H	1	--	--	CLK	HSYNC,DE,CLK
Horizontal back porch	thb	tw3H + 1	42	127	CLK	
Horizontal front porch	thf	1	67	127	CLK	
Horizontal display period	thdp	320			CLK	DE,D[27:20],D[17:10],D[07:00], CLK
DE pulse width	tw4H	320			CLK	DE,CLK

Note: This is recommended spec to get high quality picture on display. It is customer's risk to use out of this frequency.

7.4 Driving Timing Chart

-Vertical Timing

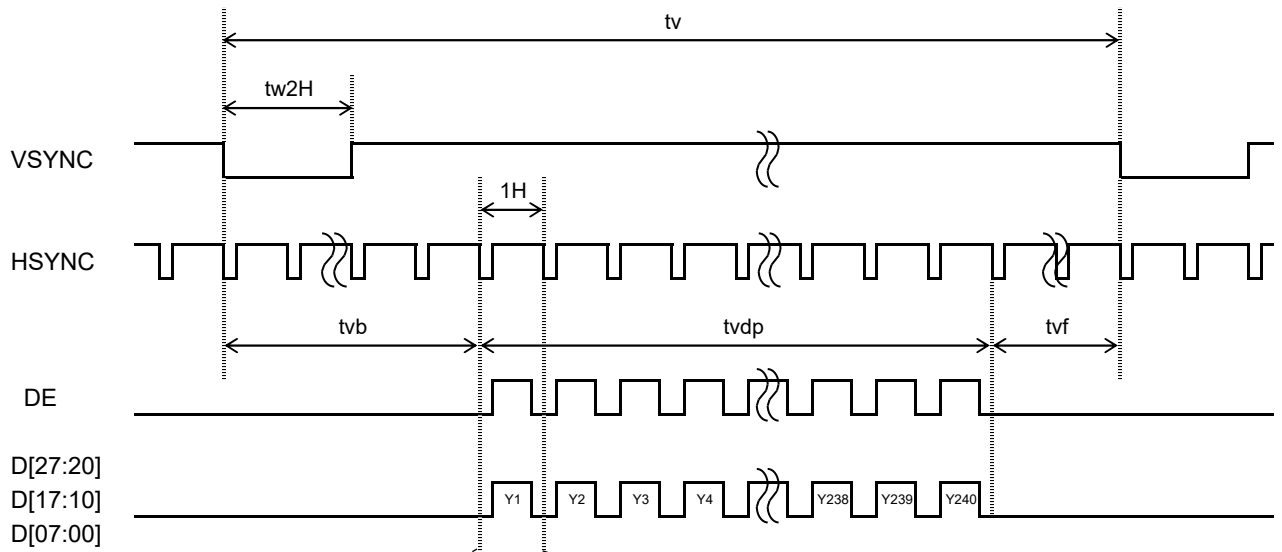

-Horizontal Timing

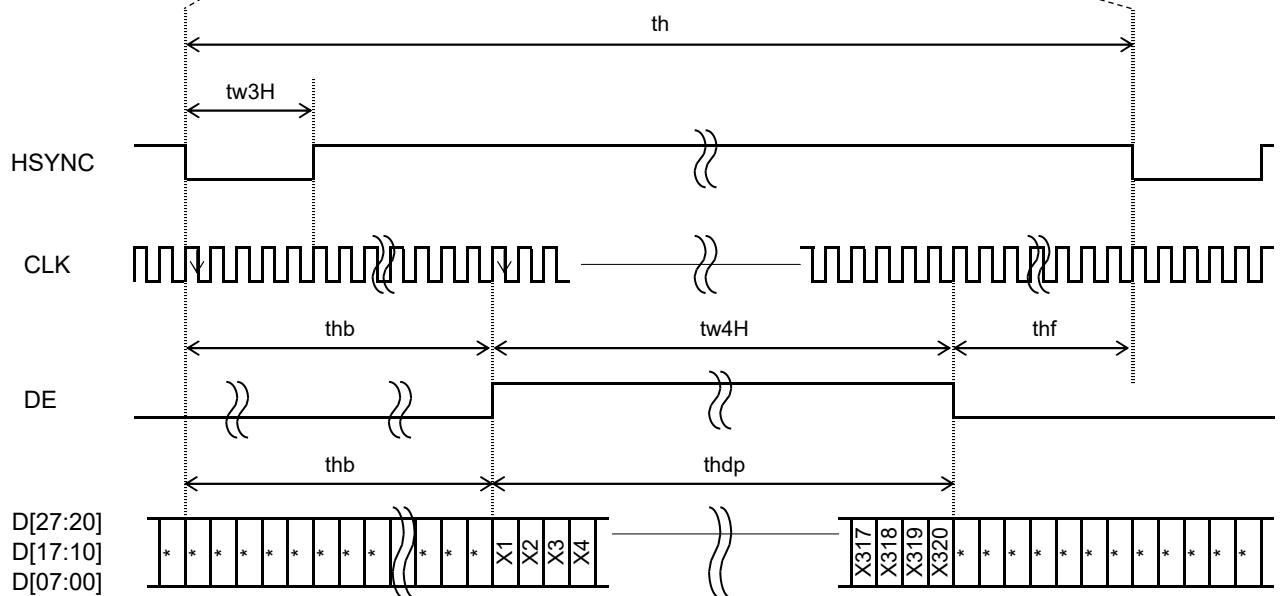

7.5 Example of Driving Timing Chart (fCLK=6.75MHz)

-Vertical Timing

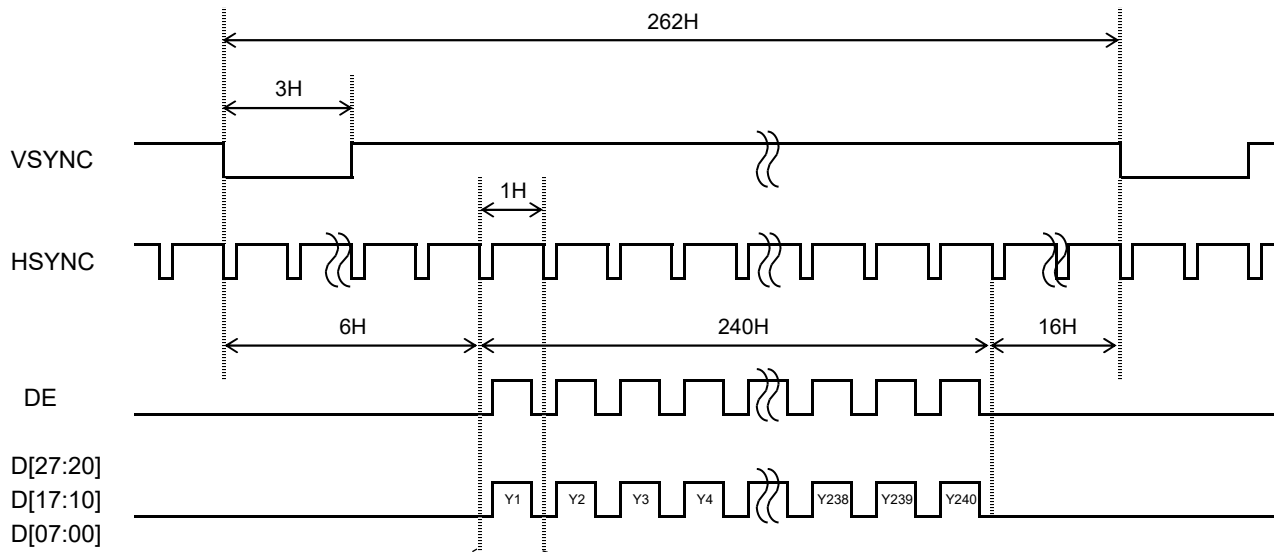

-Horizontal Timing

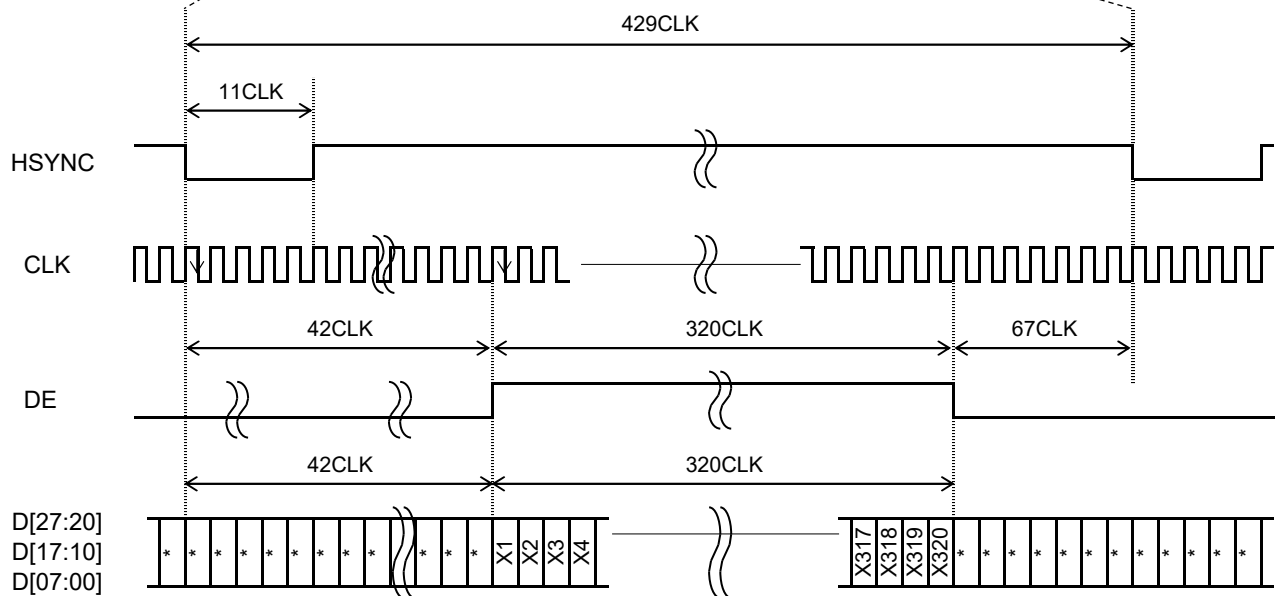

8. Description of Operation

8.1 Power On Sequence

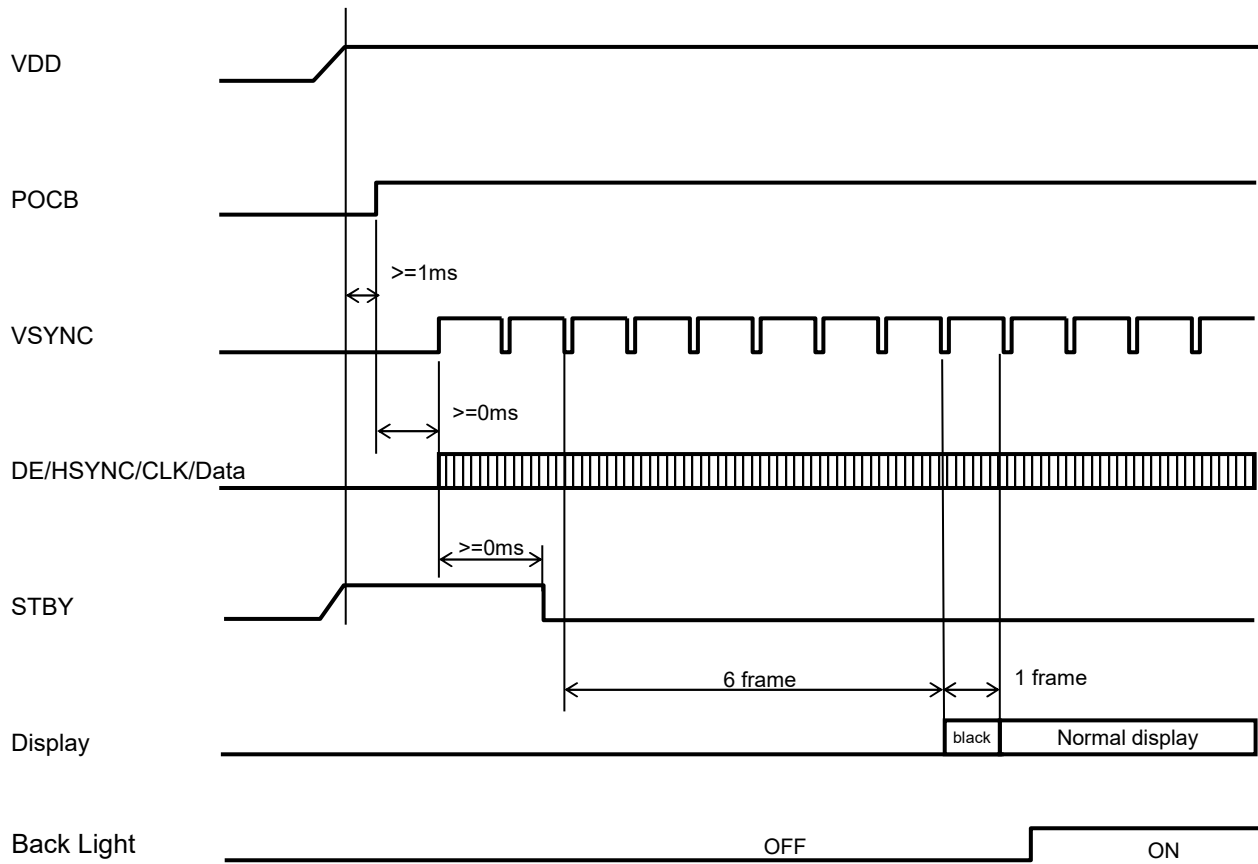

8.2 Standby / Power Off Sequence

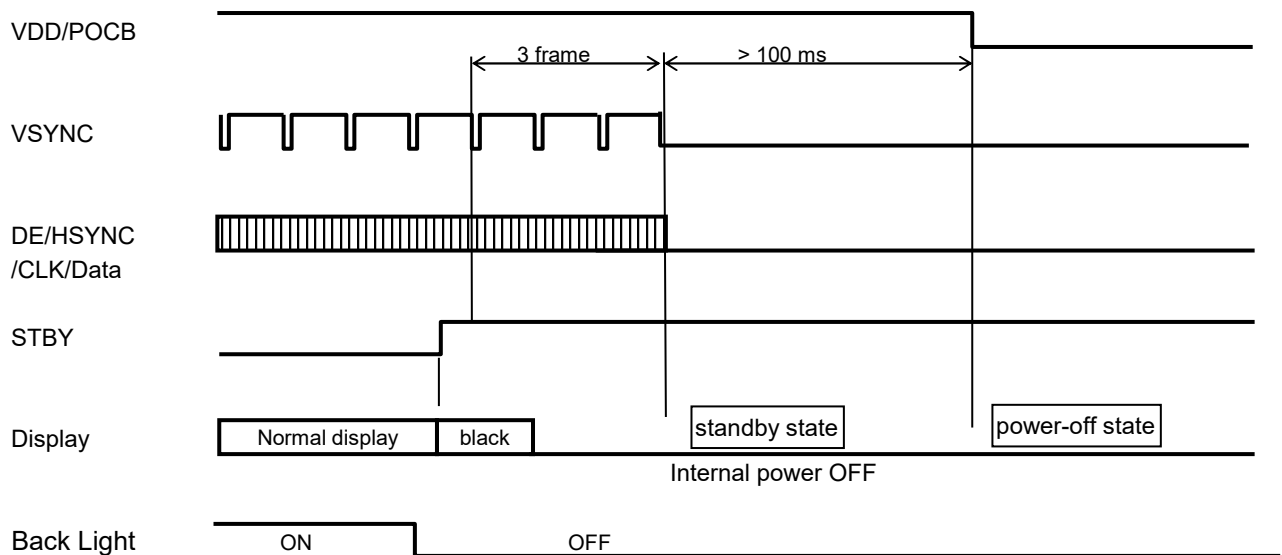

If CLK and VSYNC signals are stopped or the power supply is turned off to a regulated frame or less, the afterimage might remain.

9. Circuit

9.1 Driving Circuit Example
RGB888 (24bit)

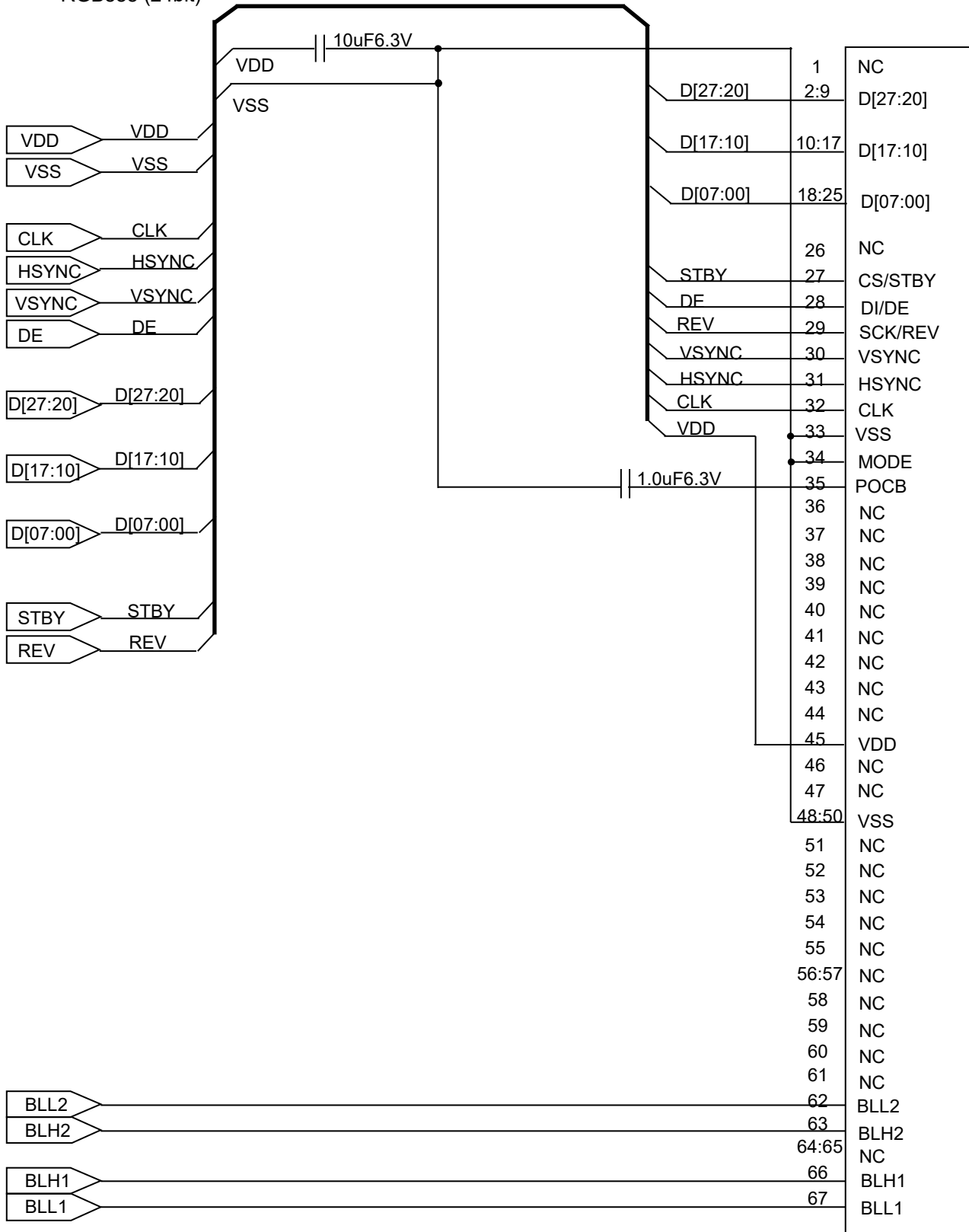

TFT LCD MODULE REFERENCE CIRCUIT

This circuit is solely for reference purpose and optimum circuit and components values may be different. User's due consideration and evaluation must be given to this circuit design and component values prior to their intended use.

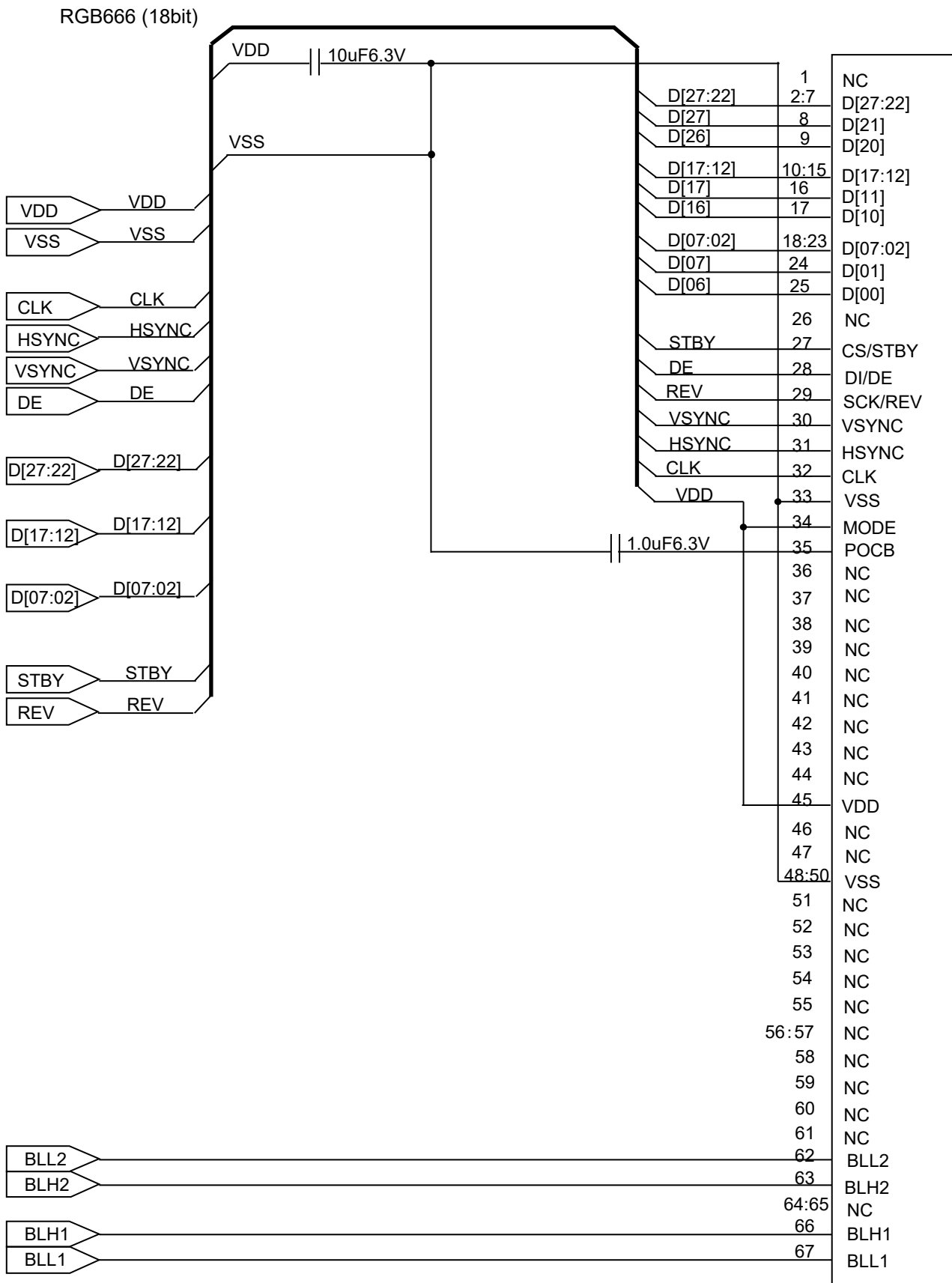

TFT LCD MODULE REFERENCE CIRCUIT

This circuit is solely for reference purpose and optimum circuit and components values may be different. User's due consideration and evaluation must be given to this circuit design and component values prior to their intended use.

9.2. LED Circuit

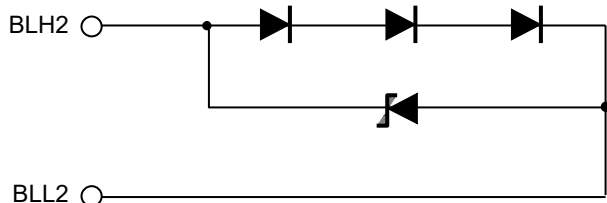
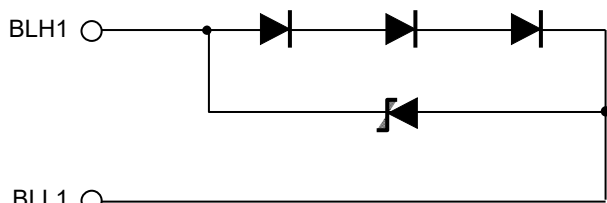

10. Characteristics

 10.1 Optical Characteristics

(Measurement Condition)

Measuring instruments: CS2000 (KONICA MINOLTA), LCD7200 (OTSUKA ELECTRONICS), EZcontrastXL88 (ELDIM)

Driving condition: VDD=3.0V, VSS=0V, Optimized VCOMDC

Backlight: IL= 8.1 mA

Measured temperature: Ta = 25°C

Item		Symbol	Condition	MIN	TYP	MAX	Unit	Note №	Remark
Response time	Rise time	TON	[Data]= 00h← → FFh	-	-	100	ms	1	
	+ Fall time	TOFF							
Contrast ratio	Backlight ON	CR	[Data]= FFh / 00h	400	800	-		2	
	Backlight OFF			-	4.5	-			
Viewing angle	Left	θL	[Data]= FFh / 00h CR \geq 10	80	-	-	deg	3	
	Right	θR		80	-	-	deg		
	Up	φU		80	-	-	deg		
	Down	φD		80	-	-	deg		
White Chromaticity		x y	[Data]= FFh	White chromaticity range				4	
Center Brightness			[Data]= FFh	420	600	-	cd/m ²	5	
Brightness distribution			[Data]= FFh	70	-	-	%	6	
Burn-in				No noticeable burn-in image shall be observed after 2 hours of window pattern display.				7	

* Note number 1 to 7: Refer to the APPENDIX of "Reference Method for Measuring Optical Characteristics and Performance".



White Chromaticity Range

(White Chromaticity Range)

x	y
0.26	0.35
0.26	0.28
0.34	0.28
0.35	0.29
0.35	0.37
0.34	0.38
0.27	0.38

 10.2 Temperature Characteristics

(Measurement Condition)

Measuring instruments: CS2000 (KONICA MINOLTA), LCD7200 (OTSUKA ELECTRONICS)

Driving condition: VDD=3.0V, VSS=0V, Optimized VCOMDC

Backlight: IL= 8.1 mA

Item		Symbol	Specification		Remark
			Ta = -20 °C	Ta = 70 °C	
Response time	Rise time + Fall time	TON + TOFF	500 msec or less	30 msec or less	
Contrast ratio		CR	200 or more	200 or more	Backlight ON
Display Quality			No noticeable display defect or ununiformity should be observed.		

11. Criteria of Judgment

 11.1 Defective Display and Screen Quality

Test Condition: Observed TFT-LCD monitor from front during operation with the following conditions

Driving Signal: Raster Patter (RGB, white, black)

Signal condition: [Data]:00h, A0h, FFh (3steps)

Observation distance: 30 cm

Illuminance: 200 to 350 lx

Backlight: IL=8.1mA

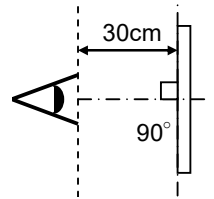

Defect item	Defect content	Criteria		
Display Quality	Line defect	Black, white or color line, 3 or more neighboring defective dots	Not exists	
	Dot defect	Uneven brightness on dot-by-dot base due to defective TFT or CF, or dust is counted as dot defect (brighter dot, darker dot)	Refer to table 1	
		High bright dot: Visible through 2% ND filter at [Data]=00h	Acceptable	
		Low bright dot: Visible through 5% ND filter at [Data]=00h Dark dot: Appear dark through white display at [Data]=A0h Invisible through 5% ND filter at [Data]=00h		
Stain	Uneven brightness (white stain, black stain etc)	Invisible through 5% ND filter at Black screen. Invisible through 1% ND filter at other screen.		
Screen Quality	Foreign particle	Point-like	$0.25\text{mm} < \phi$	N=0
			$0.20\text{mm} < \phi \leq 0.25\text{mm}$	$N \leq 2$
			$\phi \leq 0.20\text{mm}$	Acceptable
	Liner		$3.0\text{mm} < L \text{ and } 0.08\text{mm} < W$	N=0
			$L \leq 3.0\text{mm} \text{ or } W \leq 0.08\text{mm}$	Acceptable
Others		Use boundary sample for judgment when necessary		

* ϕ (mm): Average diameter = (major axis + minor axis) / 2, W (mm): Width, L (mm): Length, N: Permissible number

Table1

Area	High bright dot	Low bright dot	Dark dot	Total	Criteria
A	0	2	2	3	Permissible distance between same color bright dots (includes neighboring dots): 3 mm or more Permissible distance between same color high bright dots (includes neighboring dots): 5 mm or more
B	2	4	4	6	
Total	2	4	4	7	

<Landscape model>

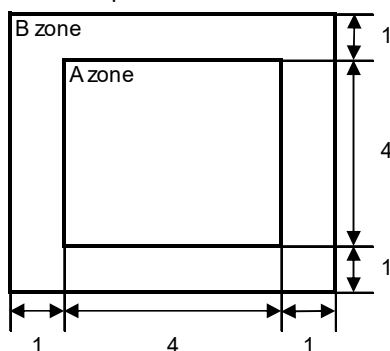

Division of A and B areas

B area: Active area

Dimensional ratio between A and B areas: 1: 4: 1

(Refer to the left figure)

11.2 Screen and Other Appearance

Testing conditions

Observation distance: 30 cm

Illuminance: 1200 ~ 2000 lx

Item		Criteria	Remark
Polarizer	Flaw	Ignore invisible defect when the backlight is on.	Applicable area: Active area only (Refer to the section 3.2 Outward Form)
	Stain		
	Dirt		
	Bubble		
	Dust		
	Dent		
S case		No functional defect occurs	
FPC		No functional defect occurs	



12. Reliability Test

Test item		Test condition	number of failures / number of examinations
Durability test	High temperature storage	Ta = 80°C 240hrs	0 / 3
	Low temperature storage	Ta = -30°C 240hrs	0 / 3
	High temperature & high humidity storage	Ta = 60°C, RH = 90%, non condensing ※	0 / 3
	High temperature operation	Tp = 70°C 240hrs	0 / 3
	Low temperature operation	Tp = -20°C 240hrs	0 / 3
	High temperature & high humidity operation	Tp = 40°C, RH = 90%, non condensing ※	0 / 3
	Thermal shock storage	-30°C ↔ 80°C (30min / 30min) 100cycles	0 / 3
Mechanical environmental test	Electrostatic discharge test (Non operation)	Confirms to EIAJ ED-4701/300, C=200pF, R=0Ω, V=±200V Each 3 times of discharge on and power supply and other terminals.	0 / 3
	Surface discharge test (Non operation)	C=250pF, R=100Ω, V=±12kV Each 5 times of discharge in both polarities on the center of screen with the case grounded.	0 / 3
	FPC tension test	Pull the FPC with the force of 3N for 10 sec. in the direction - 90-degree to its original direction.	0 / 3
	FPC bend test	Pull the FPC with the force of 3N for 10 sec. in the direction -180-degree to its original direction. Reciprocate it 3 times.	0 / 3
	Vibration test	Total amplitude 1.5mm, f=10~55Hz, X,Y,Z directions for each 2 hours	0 / 3
	Impact test	Use TOPPAN original jig (see next page) and make an impact with peak acceleration of 1000m/s ² for 6 msec with half sine-curve at 3 times to each X, Y, Z directions in conformance with JIS C 60068-2-27-2011.	0 / 3
Packing test	Packing vibration-proof test	Acceleration of 19.6m/s ² with frequency of 10→55→10Hz, X,Y, Zdirection for each 30 minutes.	0 / 1 packing
	Packing drop test	Drop from 75cm high. 1 time to each 6 surfaces, 3 edges, 1 corner	0 / 1 packing

Note: Ta=ambient temperature Tp=Panel temperature

※ The profile of high temperature/humidity storage and High Temperature/humidity operation (Pure water of over 10MΩ·cm shall be used.)

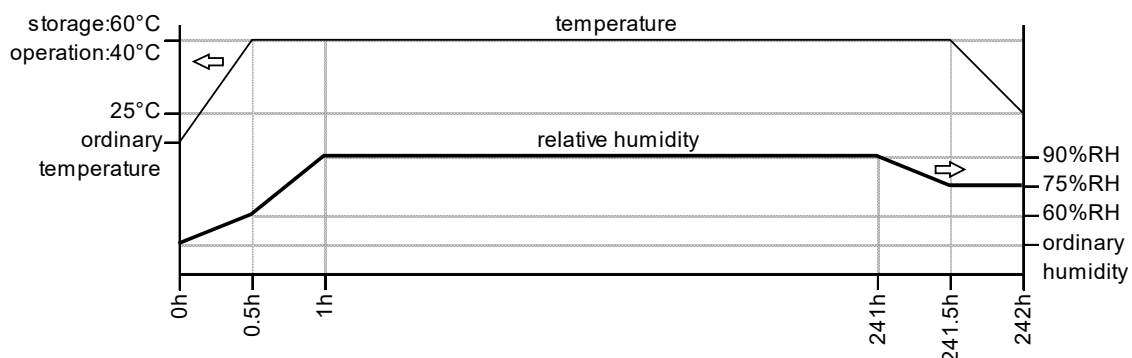
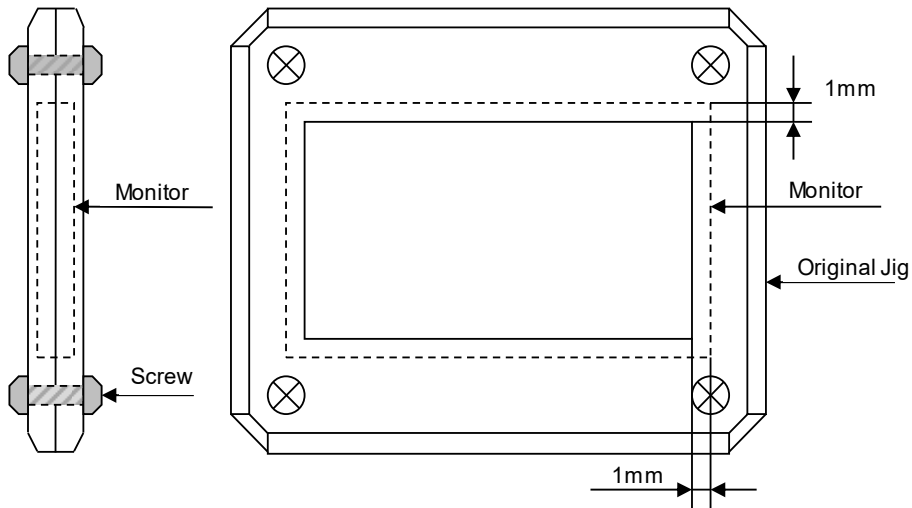

Table2. Reliability Criteria

The parameters should be measured after leaving the monitor at the ordinary temperature for 24 hours or more after the test completion.

Item	Standard	Remark
Display quality	No visible abnormality shall be seen. (Except for unevenness by PoI deterioration.)	
Contrast ratio	200 or more	Backlight ON

TOPPAN Original Jig



FPC tension test

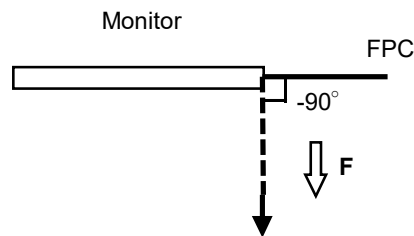

FPC bend test

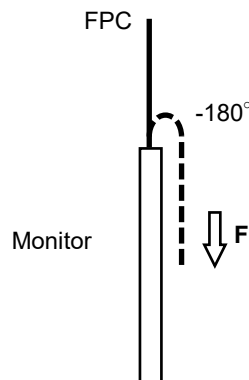



13. Packing Specifications

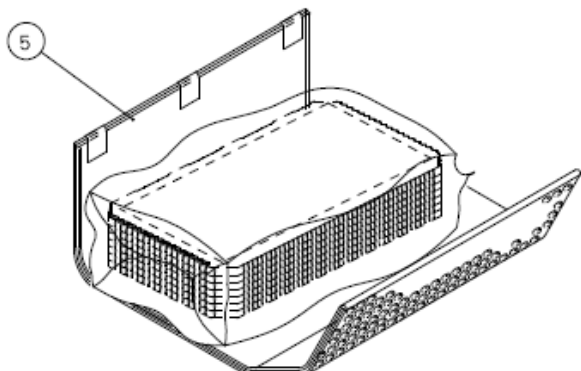
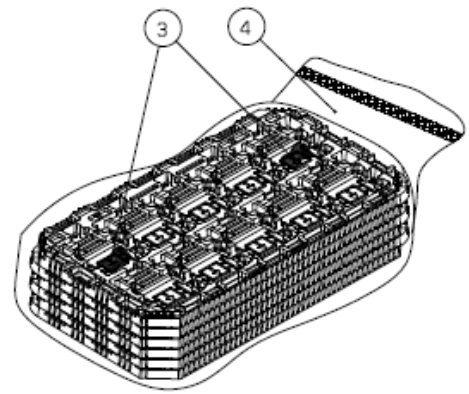
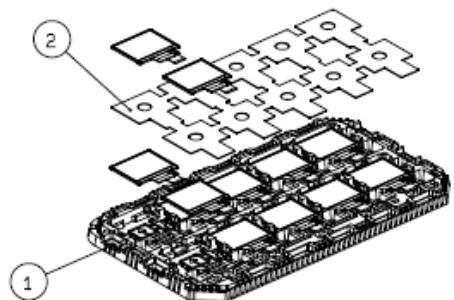

- Step1. Arrange a product with display side up according to the shape of the convex part of the tray, and insert the foam sheet on the products.
(10 Module per the first stage)
Arrange a product with display side up.
(10 Module per the second stage)
- Step2. The trays be in a stack of 5. (Rotate 180 degrees for each step)
One empty tray is to be put on the top of stack of 5 trays.
- Step3. 2 packs of moisture absorbers are to be placed on the top tray as shown in the drawing. Put piled trays into a sealing bag.
- Step4. Vacuum and seal the sealing bag with the vacuum sealing machine.
- Step5. The stack of trays in the sealing bag is to be wrapped with a B SHEET A.
- Step6. The wrapped trays are placed in the outer carton.
- Step7. B SHEET B are to be inserted into the outer carton with same orientation. The outer carton is to be sealed in H-shape with packing tape as shown in the drawing.
- Step8. The model number, quantity of products, and shipping date are to be printed on the outer carton.
If necessary, shipping labels or impression markings are to be put on the outer carton.

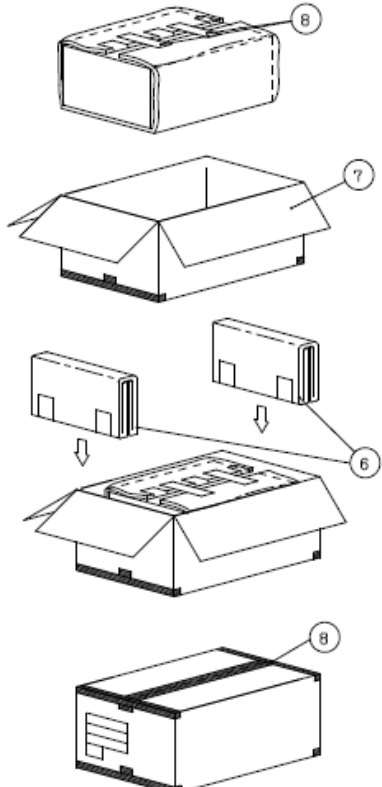

Remark: The return of packing materials is not required.

	Packing item name	Specs., Material
①	Tray	A-PET
②	Foam sheet	Anti-static polyethylene
③	Drier	Moisture absorber
④	Sealing bag	
⑤	B SHEET A	Antistatic air bubble sheet
⑥	B SHEET B	Antistatic air bubble sheet
⑦	Outer carton	Corrugated cardboard
⑧	Packing tape	

Dimension of outer carton	
D : Approx.	(356mm)
W : Approx.	(664mm)
H : Approx.	(182mm)
Quantity of products packed in one cart	100
Gross weight : Approx.	5.4kg

14. Handling Instruction

14.1 Cautions for Handling LCD panels



Caution

- (1) Do not make an impact on the LCD panel glass because it may break and you may get injured from it.
- (2) If the glass breaks, do not touch it with bare hands.
(Fragment of broken glass may stick you or you cut yourself on it.)
- (3) If you get injured, receive adequate first aid and consult a medial doctor.
- (4) Do not let liquid crystal get into your mouth.
(If the LCD panel glass breaks, try not let liquid crystal get into your mouth even toxic property of liquid crystal has not been confirmed.)
- (5) If liquid crystal adheres, rinse it out thoroughly.
(If liquid crystal adheres to your cloth or skin, wipe it off with rubbing alcohol or wash it thoroughly with soap. If liquid crystal gets into eyes, rinse it with clean water for at least 15 minutes and consult an eye doctor.)
- (6) If you scrap this products, follow a disposal standard of industrial waste that is legally valid in the community, country or territory where you reside.
- (7) Do not connect or disconnect this product while its application products is powered on.
- (8) Do not attempt to disassemble or modify this product as it is precision component.
- (9) If a part of soldering part has been exposed, and avoid contact (short-circuit) with a metallic part of the case etc. about FPC of this model, please.
Please insulate it with the insulating tape etc. if necessary.
The defective operation is caused, and there is a possibility to generation of heat and the ignition.
- (10) Since excess current protection circuit is not built in this TFT module, there is the possibility that LCD module or peripheral circuit become feverish and burned in case abnormal operation is generated.
We recommend you to add excess current protection circuit to power supply.
- (11) The devices on the FPC are damageable to electrostatic discharge, because the terminals of the devices are exposed.
Wear grounded wrist-straps and use electrostatic neutralization blowers to prevent static charge and discharge when handling the TFT monitors.
Designate an appropriate operating area, and set equipment, tools, and machines properly when handling this product.

Caution



This mark is used to indicate a precaution or an instruction which, if not correctly observed, may result in bodily injury, or material damages alone.

14.2 Precautions for Handling

- 1) Wear finger tips at incoming inspection and for handling the TFT monitors to keep display quality and keep the working area clean.
Do not touch the surface of the monitor as it is easily scratched.
- 2) Wear grounded wrist-straps and use electrostatic neutralization blowers to prevent static charge and discharge when handling the TFT monitors as the LED in this TFT monitors is damageable to electrostatic discharge.
Designate an appropriate operating area, and set equipment, tools, and machines properly when handling this product.
- 3) Avoid strong mechanical shock including knocking, hitting or dropping to the TFT monitors for protecting their glass parts.
Do not use the TFT monitors that have been experienced dropping or strong mechanical shock.
- 4) Do not use or storage the TFT monitors at high temperature and high humidity environment.
Particularly, never use or storage the TFT monitors at a location where condensation builds up.
- 5) Avoid using and storing TFT monitors at a location where they are exposed to direct sunlight or ultraviolet rays to prevent the LCD panels from deterioration by ultraviolet rays.
- 6) Do not stain or damage the contacts of the FPC cable .
FPC cable needs to be inserted until it can reach to the end of connector slot.
During insertion, make sure to keep the cable in a horizontal position to avoid an oblique insertion.
Otherwise, it may cause poor contact or deteriorate reliability of the FPC cable.
- 7) Do not bend or pull the FPC cable or carry the TFT monitor by holding the FPC cable.
Especially, it will cause mechanical damage or critical defect if FPC is pull up or bent up to short of display.

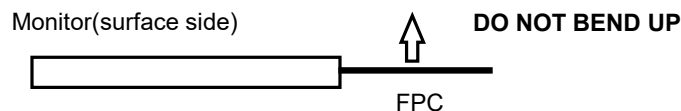

- 8) Peel off the protective film on the TFT monitors during mounting process.
Refer to the section 14.5 on how to peel off the protective film.
We are not responsible for electrostatic discharge failures or other defects occur when peeling off the protective film.

14.3 Precautions for Operation

- 1) Since this TFT monitors are not equipped with light shielding for the driver IC,
do not expose the driver IC to strong lights during operation as it may cause functional failures.
- 2) In case of powering up or powering off this LCD module,
be sure to comply the sequence as instructed in this specification.
- 3) Do not plug in or out the FPC cable while power supply is switch on.
Plug the FPC cable in and out while power supply is switched off.
- 4) Do not operate the TFT monitors in the strong magnetic field. It may break the TFT monitors.
- 5) Do not display a fixed image on the screen for a long time.
Use a screen-saver or other measures to avoid a fixed image displayed on the screen for a long time.
Otherwise, it may cause burn-in image on the screen due the characteristics of liquid crystal.



14.4 Storage Condition for Shipping Cartons

(Storage environment)

- Temperature 0 to 40° C
- Humidity 60%RH or less
No-condensing occurs under low temperature with high humidity condition.
- Atmosphere No poisonous gas that can erode electronic components and/or wiring materials should be detected.
- Time period 1 year
- Unpacking To prevent damages caused by static electricity, anti-static precautionary measures (e.g. earthing, anti-static mat) should be implemented.
After unpack, keep product in the appropriate condition, otherwise bubble seal of Protective film may be printed on Polarizer.
- Maximum piling up 8 cartons (excluding the bottom)

*Conditions to storage after unpacking

(Storage environment)

- Temperature 0 to 40° C
- Humidity 60%RH or less
No-condensing occurs under low temperature with high humidity condition.
- Atmosphere No poisonous gas that can erode electronic components and/or wiring materials should be detected.
- Time period 1 year (Shelf life)
- Others Keep/ store away from direct sunlight
Storage goods on original tray made by TOPPAN.



14.5 Precautions for Peeling off the Protective film

The followings work environment and work method are recommended to prevent the TFT monitors from static damage or adhesion of dust when peeling off the protective films.

A) Work Environment

- a) Humidity: 50 to 70 %RH, Temperature 15 to 27° C
- b) Operators should wear conductive shoes, conductive clothes, conductive finger tips and grounded wrist-straps.
Use an electrostatic neutralization blower.
- c) Anti-static treatment should be implemented to work area's floor.
Use a room shielded against outside dust with sticky floor mat laid at the entrance to eliminate dirt.

B) Work Method

The following procedures should taken to prevent the driver ICs from charging and discharging.

- a) Use an electrostatic neutralization blower to blow air on the TFT monitors to its lower left when FPC is placed at the bottom.
Optimize direction of the blowing air and the distance between the TFT monitors and the electrostatic neutralization blower.
- b) Put an adhesive tape (Scotch tape, etc) at the lower left corner area of the protective film to prevent scratch on surface of TFT monitors.
- c) Peel off the adhesive tape slowly (spending more than 2 secs to complete) by pulling it to opposite direction.

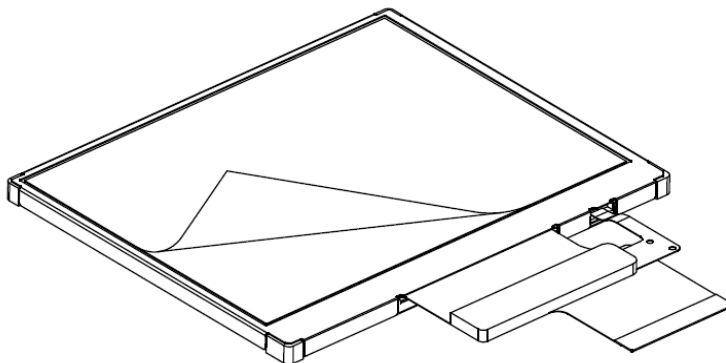

Blower wind direction
(Set an ion blower with its adequate conditions.)

14.6 Warranty

TOPPAN is only liable to defective goods which is stored and used under the condition complying with this specifications and returned within 1 (one) year.

Warranty caused by manufacturing defect shall be conducted by replacement of goods or refundment at unit price.

APPENDIX

Reference Method for Measuring Optical Characteristics and Performance

1. Measurement Condition (Backlight ON)

Measuring instruments: CS2000 (KONICA MINOLTA), LCD7200 (OTSUKA ELECTRONICS), EZcontrastXL88 (ELDIM)

Driving condition: Refer to the section "Optical Characteristics"

Measured temperature: 25°C unless specified

Measurement system: See the chart below. The luminance meter is placed on the normal line of measurement system.

Measurement point: At the center of the screen unless otherwise specified

Dark box at constant temperature

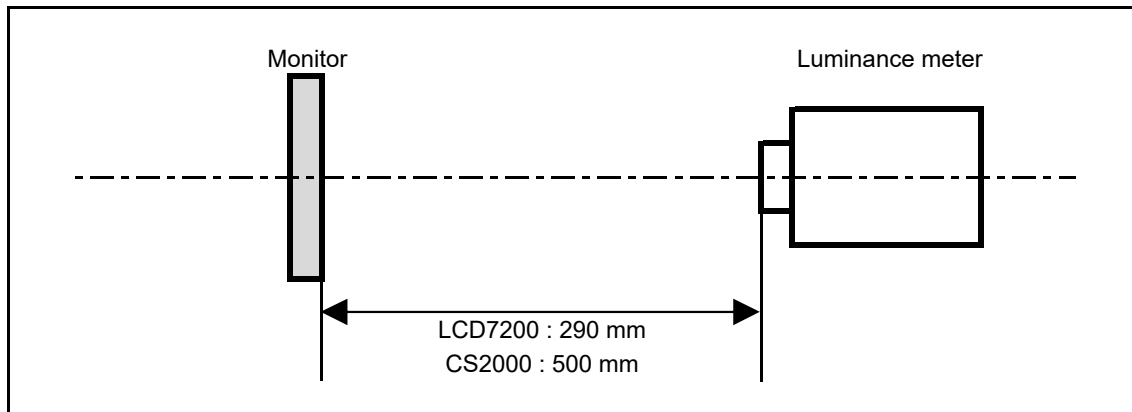

*Measurement is made after 30 minutes of lighting of the backlight.

Measurement point: At the center point of the screen

Brightness distribution: 9 points shown in the following drawing.

<Landscape model>

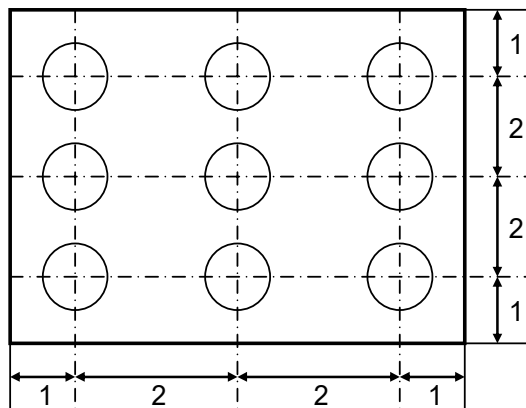

Dimensional ratio of active area

Backlight IL= 8.1mA



Measurement Condition (Contrast ratio Backlight OFF only)

Measuring instruments: LCD7200(OTSUKA ELECTRONICS) , Ring Light (40,000 lx, $\phi 58$)

Driving condition: Refer to the section "Optical Characteristics"

Measured temperature: 25°C unless specified

Measurement system: See the chart below.

Measurement point: At the center of the screen unless otherwise specified

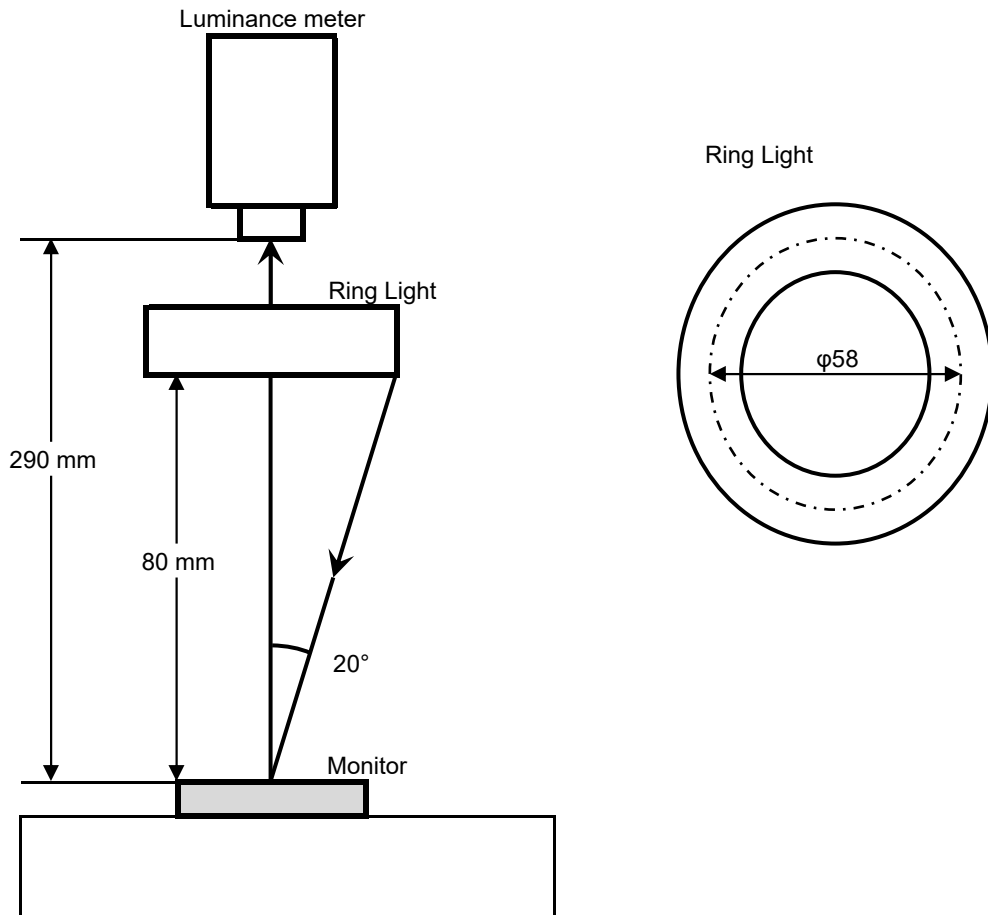

2. Test Method

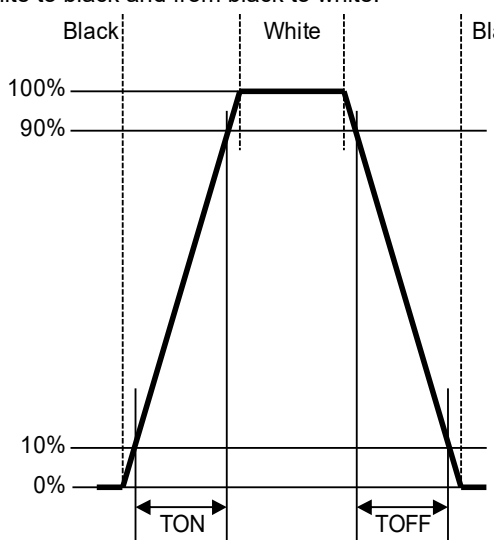
Notice	Item	Test method	Measuring instrument	Remark
1	Response time	Measure output signal waveform by the luminance meter when raster of window pattern is changed from white to black and from black to white. 	LCD7200	Black display [Data]=00h White display [Data]=FFh TON Rise time TOFF Fall time
2	Contrast ratio	Measure maximum luminance Y1([Data]=FFh) and minimum luminance Y2([Data]=00h) at the center of the screen by displaying raster or window pattern. Then calculate the ratio between these two values. $\text{Contrast ratio} = Y1/Y2$ Diameter of measuring point: 7.8mmφ(CS2000) Diameter of measuring point: 3mmφ(LCD7200)	CS2000 LCD7200	Backlight ON Backlight OFF
3	Viewing angle Horizontalθ Verticalφ	Move the luminance meter from right to left and up and down and determine the angles where contrast ratio is 10.	EZcontrastXL88	
4	White chromaticity	Measure chromaticity coordinates x and y of CIE1931 colorimetric system at [Data] = FFh Color matching function: 2°view measurement angle: 1°	CS2000	
5	Center brightness	Measure the brightness at the center of the screen.	CS2000	
6	Brightness distribution	$(\text{Brightness distribution}) = 100 \times B/A \%$ A : max. brightness of the 9 points B : min. brightness of the 9 points	CS2000	
7	Burn-in	Visually check burn-in image on the screen after 2 hours of "window display" ([Data]=00h/FFh).		At optimized VCOMDC