



镇江全诚电气科技有限公司



0511-86212086



丹阳市前艾众创工业园B6

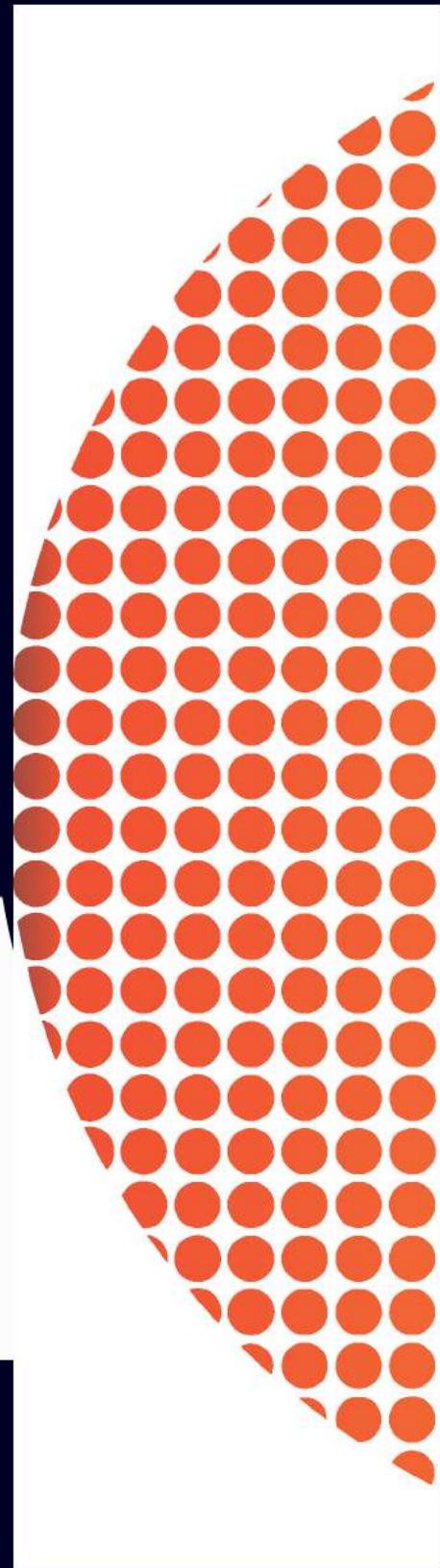

ALL

ALL ELECTRICAL TECHNOLOGY

全诚电气科技

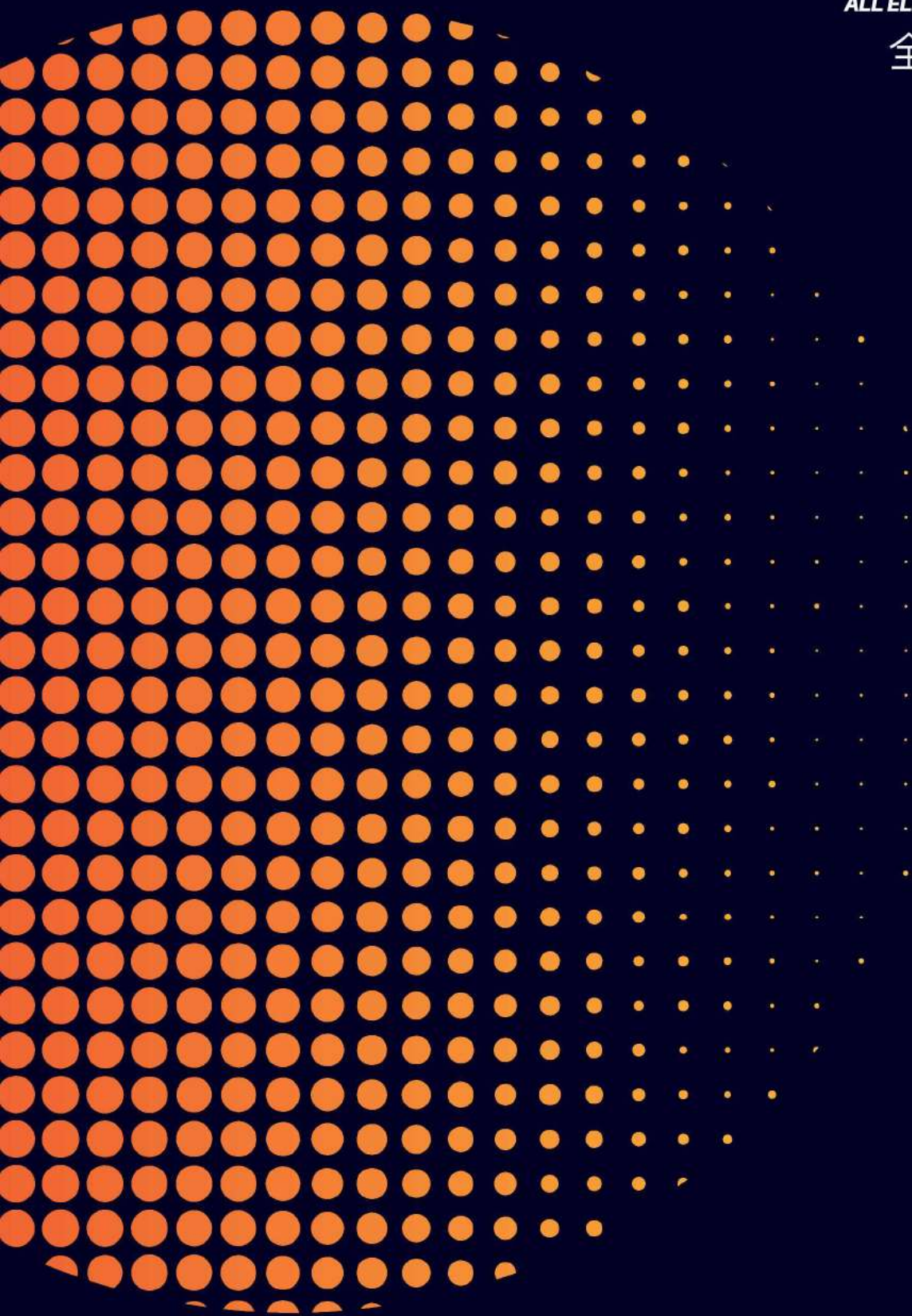

镇江全诚电气科技有限公司

ABOUT ALL

镇江全诚电气科技有限公司崛起于长江三角洲经济强档板块区域,专业从事半导体功率器件的研究,设计,开发,制造与销售。

国企改制后的全诚电气具有近40年电力半导体元器件制造经验和长期从事半导体器件设计和制造的专业人才。注重质量与研发的全诚电气是一家已拥有20余项专利的国家级高新技术企业。

公司研发制造与销售的主要产品有功率半导体芯片, KP晶闸管, ZP整流管, KS双向管, KK快速管。各类全控, 半控, 整流模块。温度控制器, 固态继电器, SCR调功器/调压器。成套电加热柜, 调速电源, 整流电源柜, 中频电源。焊机专用三相全控, 半控, 整流, 六相半波, 共阴共阳, 美国林肯, 米勒型可控硅。以及自主研发生产的RF, RM, 高倍齿, 可控硅专用散热器。产品应用于: 电力机车, 工业加热, 发配电, 电焊机, 电解电镀, 轧钢, 变频器, 软启动, 电机调速, 无功补偿, 电动汽车充电桩产品, 家用电器和UPS领域。

历年来, 全诚电气始终坚持以品质赢得信赖的发展理念, 通过了ISO9001、ISO20000质量体系认证。公司技术力量雄厚, 生产手段先进, 制造工艺精湛, 选用材料优质, 检测设备精良, 质量稳定可靠, 得到了行业机构和客户的一致认可, 品牌认知度、美誉度和影响力均稳步提升, 产品行销全国, 并部分出口配套外销。

真诚携手, 共赢同享, 镇江全诚电气科技有限公司愿与您携手共进, 开创未来。

Zhenjiang quancheng electric technology co., LTD., founded in the Yangtze river delta, is specialized in the research, design, development, manufacture and sales of semiconductor power devices.

After the restructuring of state-owned enterprises, quancheng electric has nearly 40 years of experience in the manufacture of power semiconductor components and has been engaged in the design and manufacture of semiconductor devices for a long time. Quancheng electric, which focuses on quality and research and development, is a state-level high-tech enterprise with more than 20 patents.

The main products of the company include power semiconductor chip, KP thyristor, ZP rectifier, KS bidirectional tube and KK rapid tube. All kinds of full control, half control, rectifier modules. Temperature controller, solid state relay, SCR regulator/regulator. Complete set of electric heating cabinet, speed regulating power supply, rectifying power supply cabinet, intermediate frequency power supply. Dedicated three - phase full control, half control, rectifier, six - phase half wave, total Yin and total Yang, Lincoln, miller type SCR. And the RF, RM, high - power tooth, silicon - controlled radiator. Products are used in: electric locomotive, industrial heating, power generation and distribution, welding machine, electroplating, steel rolling, frequency converter, soft start, motor speed regulation, reactive power compensation, electric vehicle charging pile products, household appliances and UPS field.

Over the years, quancheng electric has always adhered to the development concept of winning trust by quality, and passed the ISO9001 and ISO20000 quality system certification. The company has strong technical force, advanced production means, exquisite manufacturing process, high quality selected materials, sophisticated testing equipment, stable and reliable quality, which has been unanimously recognized by industry institutions and customers. The brand awareness, reputation and influence have been steadily improved, and the products have been sold throughout the country, and some of them have been exported for export.

Zhenjiang quancheng electric technology co., ltd. is willing to join hands with you to create the future.

参数文字符号一览表 | Symbolic Meaning

产品类型	参数符号 Parameter symbol	参数名称	Parameter Name
整流管	V_{RRM}	反向重复峰值电压	Repetitive peak reverse voltage
	V_{FM}	正向峰值电压	Peak forward voltage
	$V_{F(AV)}$	正向平均电压	Mean forward voltage
	V_{FO}	门槛电压	Threshold voltage
	$I_{F(RSM)}$	正向方均根电流	Rms forward current
	$I_{F(AV)}$	正向平均电流	Mean forward current
	I_{FMS}	浪涌电流	Surge forward current
	I_{RRM}	反向重复峰值电流	Repetitive peak reverse current
	$I_{RR(AV)}$	反向重复平均电流	Repetitive mean reverse current
	I^2t	I^2t	I squared t
	T_j	工作结温	Operating junction temperature
	T_{stg}	贮存温度	Storage temperature
	Q_{rr}	恢复电荷	Recovery time
	t_{rr}	反向恢复时间	Reverse recovery time
	R_{jc}	结壳热阻	Thermal resistance junction-case
	r_{FO}	正向斜率电阻	Forward slope resistance
晶闸管	I_{RRM}	反向重复峰值电流	Repetitive peak reverse current
	$I_{RR(AV)}$	反向重复平均电流	Repetitive mean reverse current
	I_{GT}	门极触发电流	Gate trigger current
	I_H	维持电流	Holding current
	I_{GM}	门极峰值电流	Peak gate current
	I^2t	I^2t	I squared t
	P_{GM}	门极峰值功率	Peak gate power
	$P_{G(AV)}$	门极平均功率	Mean gate power
	T_j	工作结温	Operating junction temperature
	t_{gt}	门极控制开通时间	Gate-controlled turn-on time
	t_q	电路换向关断时间	Circuit-committed turn-off time
	dv/dt	断态电压临界上升率	Critical rate of rise of off-state voltage
	r_{TO}	通态斜率电阻	On-state slope resistance
	T_{stg}	贮存温度	Storage temperature
	V_{RRM}	反向重复峰值电压	Repetitive peak reverse voltage
	V_{DRM}	断态重复峰值电压	Repetitive peak off-state voltage
	V_{RGM}	门极反向峰值电压	Peak reverse gate voltage
	V_{TM}	通态峰值电压	Peak on-state voltage
	$V_{T(AV)}$	通态平均电压	Mean on-stage voltage
	V_{GT}	门极触发电压	Gate trigger voltage
	V_{GD}	门极不触发电压	Gate non-trigger voltage
	V_{TO}	通态门槛电压	On-state threshold voltage
	V_{GM}	门极峰值电压	Peak gate voltage
	$V_{T(RMS)}$	通态方均根电压	R.M.S on-state voltage
	$I_{T(AV)}$	通态平均电流	Mean on-state current
	$I_{T(RMS)}$	通态方均根电流	R.M.S on-state current
	I_{FGM}	门极正向峰值电流	Forward gate current
	I_{DRM}	断态重复峰值电流	Repetitive peak off-state current
	$I_{DR(AV)}$	断态重复平均电	Repetitive mean off-state current
	I_{TSM}	浪涌电流	Surge on-state current

全诚产品型号命名规则 | Runau nomenclature

KP 1000 - **

两个字母代表器件的种类

The type of the devices

ZP 普通整流管 General Purpose Rectifiers

KP 普通晶闸管 Phase Control Thyristors

ZK 快速整流管 Fast Recovery Rectifiers

KK 快速晶闸管 Fast Switching Thyristors

KS 双向晶闸管 Triacs

ZW 焊接整流管 Welding Diodes

额定电压级数

Rated Voltage Class ($** \times 100 = V_{DRM} / V_{RRM}$)

额定电流

Rated Current $I_{T(AV)} / I_{F(AV)}$

TT 200 - **

器件类别 Device Type

TT: 双晶闸管 Dual Thyristors

TD: 晶闸管 / 整流管 Thyristor with Diode

DT: 整流管 / 晶闸管 Diode with Thyristor

DD: 双整流管 Dual Diodes

TZ: 单晶闸管 Single Thyristor

DZ: 单整流管 Single Diode

额定电压级数

Rated Voltage Class ($** \times 100 = V_{DRM} / V_{RRM}$)

额定电流

Rated Current $I_{T(AV)} / I_{F(AV)}$

M T C 90 - **

模块

Module

器件类别 Device Type

D: 普通整流管 General Purpose Rectifiers

T: 普通晶闸管 Phase Control Thyristors

Z: 快速整流管 Fast Recovery Rectifiers

K: 快速晶闸管 Fast Switching Thyristors

F: D&T

H: Z&K

额定电压级数

Rated Voltage Class ($** \times 100 = V_{DRM} / V_{RRM}$)

额定电流

Rated Current $I_{T(AV)} / I_{F(AV)}$

电路形式 Circuit Form

C: 串联 Series

K: 共阴极 Common Cathode

A: 共阳极 Common Anode

Y: 三相共阴极 Three Phase Common Cathode

G: 三相共阳极 Three Phase Common Anode

X: 反并联 Aniparalle

Q: 单相桥 Single Phase Bridge

S: 三相桥 Three Phase Bridge

目录

TABLE OF CONTENTS

1

功率半导体芯片 Power Semiconductor Chips

晶闸管芯片 Thyristor Chips

整流管芯片 Diodes Chips

2

平板式器件 Capsule Type Device

普通晶闸管 Phase Control Thyristor

快速晶闸管 Fast Switching Thyristor

普通整流管 Rectifier Diode

整流管外形图 Outline of Capsule Type Diode

晶闸管外形图 Outline of Capsule Type Thyristor

焊接二极管 Welding Diode

3

功率半导体模块 Power Module

晶闸管模块 Thyristor Module

整流管模块 Diode Module

晶闸管/整流管混合模块 Thyristor/Diode Module

模块外形图 Outline of Power Module

4

三相电力调整器 SCR Power Regulator

5

电力调整温度控制柜 Electric adjustment temperature control cabinet

6

散热器 Radiator

7

组件系列 Module

8

资质和证书 Qualifications and certificates

1

功率半导体芯片 Power Semiconductor Chips

晶闸管芯片 Thyristor Chips

整流管芯片 Diodes Chips



标准

- 每片芯片全部在 T_{JM} 下测试, 严格禁止抽检
- 产品参数一致性极佳

Standard:

- Every chips are tested at T_{JM}, random inspections are strictly prohibited.
- Excellent consistency of the chips' parameters

特点

- 通态压降低
- 具有很强的抗热疲劳能力
- 阴极铝层厚度 4 微米以上
- 台面双层保护

Features:

- Low forward voltage
- Strong thermal fatigue resistance
- The thickness of cathode aluminum layer is above 4 μm
- Double layer protections on mesa



芯片直径	芯片厚度	电压范围	门极直径	阴极内径	阴极外径	结温
Diameter	Thickness	Voltage	Gate Dia.	Cathode Inner Dia.	Cathode Out Dia.	T _{JM}
mm	mm	V	mm	mm	mm	°C
17	1.5±0.1	≤2600	1.8	3.8	12.5	125
24	1.5±0.1	≤2000	2.5	5.6	20.3	125
26	1.6-1.8	≤3500	2.6	5.6	15.9	125
30	2±0.1	≤3500	3.3	7.7	24.5	125
32	2±0.1	≤2000	3.3	7.7	26.1	125
35	2±0.1	≤3500	3.8	7.6	29.1	125
36	2.1-2.4	≤2000	3.8	7.6	24.9	125
40	2±0.1	≤2000	3.3	7.7	33.9	125
	2.1-2.4	2200-4200	3.5	8.1	30.7	125
45	2.3±0.1	≤2000	3.6	8.8	37.9	125
50	2.5±0.1	≤2000	3.6	8.8	43.3	125
	2.6-2.9	2200-4200	3.8	8.6	41.5	125
	2.6-2.8	2600-3500	3.3	7	41.5	125
55	2.5±0.1	≤2000	3.3	8.8	47.3	125
	2.5-2.9	≤4200	3.8	8.6	45.7	125
60	2.6-3.0	≤4200	3.8	8.6	49.8	125
65	2.7-3.1	≤4200	3.8	8.6	53.4	125
70	3.0-3.4	≤4200	5.2	10.1	59.9	125
76.2	3.5-4.1	≤4800	5.2	10.1	65.1	125

标准

- 每片芯片全部在 TJM 下测试, 严格禁止抽检
- 产品参数一致性极佳

Standard:

- Every chips are tested at TJM, random inspections are strictly prohibited.
- Excellent consistency of the chips' parameters

特点

- 通态压降低
- 具有很强的抗热疲劳能力
- 阴极铝层厚度 4 微米以上
- 台面双层保护

Features:

- Low forward voltage
- Strong thermal fatigue resistance
- The thickness of cathode aluminum layer is above 4 μm
- Double layer protections on mesa

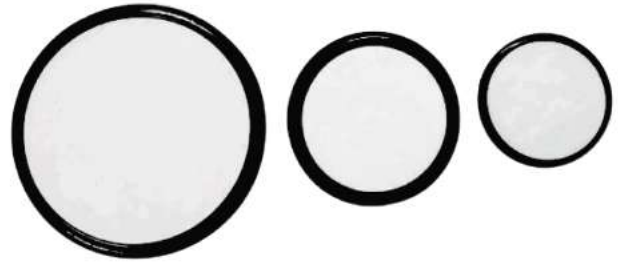

芯片直径	芯片厚度	电压范围	阴极外径	结温
Diameter	Thickness	Voltage	Cathode Out Dia.	T_{J}
mm	mm	V	mm	$^{\circ}\text{C}$
17	1.5±0.1	≤2600	12.5	150
24	1.5±0.1	≤2600	18.5	150
26	1.4-1.7	≤3500	19.5	150
30	1.95±0.1	≤2600	25	150
	1.9-2.3	2800-5500	23	150
32	1.9±0.1	≤2200	27.5	150
	2±0.1	2400-2600	26.3	150
35	1.8-2.1	≤3500	29	150
	2.2±0.1	3600-5000	27.5	150
36	2.1±0.1	≤2200	31	150
40	1.9-2.2	≤3500	33.5	150
	2.2-2.5	3600-6500	31.5	150
45	2.3±0.1	≤3000	39.5	150
	2.5±0.1	3600-4500	37.5	150
50	2.4-2.7	≤4000	43.5	150
	2.8±0.1	4200-5000	41.5	150
55	2.4-2.8	≤4500	47.7	150
	2.8-3.1	5200-6500	44.5	150
60	2.6-3.0	≤4500	49.8	150
65	3.0-3.3	5200-6500	53.4	150
70	2.9-3.1	≤3200	63.5	150
	3.2±0.1	3400-4500	62	150
76.2	3.4-3.8	≤4500	68.1	150

2

平板式器件 Capsule Type Device

普通晶闸管 Phase Control Thyristor

快速晶闸管 Fast Switching Thyristor

普通整流管 Rectifier Diode

整流管外形图 Outline of Capsule Type Diode

晶闸管外形图 Outline of Capsule Type Thyristor

焊接二极管 Welding Diode



特点

- 全扩散结构
- 分布门极设计
- dv/dt 能力高
- 低通态压降
- 开关损耗小

Features:

- All Diffused Structure
- Distributed gate design
- High dv/dt capability
- Low on-state voltage
- Low switching loss

应用领域

- 机车牵引与传动
- 高压直流输电
- 高压无功功率因素补偿
- 大电流电源、电机软启动
- 电机励磁、感应加热

Applications:

- Traction and transmission
- HVDC, SVC
- High current power supply
- Soft-starter, Motor excitation
- Induction heating



型号	$I_{T(AV)}$	TC	V_{DRM}/V_{RRM}	$I_{TSM} @ T_{VJM}$ & 10ms	I^2t	V_{TM} @ I_T & $T_J = 25^\circ C$		T_{JM}	R_{jc}	R_{cs}	F	m	外形
TYPE	A	$^\circ C$	V	A	A^2s	V	A	$^\circ C$	$^\circ C/W$	$^\circ C/W$	KN	Kg	Outline
电压至 1800V(Up to 1800V)													
KP100-**	320	70	1200~1800	3840	7.4×10^4	1.60	600	125	0.08	0.02	4	0.060	Th-1A
KP200-**	320	70	1200~1800	3840	7.4×10^4	1.60	600	125	0.08	0.02	4	0.060	Th-1A
KP300-**	320	70	1200~1800	3840	7.4×10^4	1.60	600	125	0.08	0.02	4	0.060	Th-1A
KP320-**	320	70	1200~1800	3840	7.4×10^4	1.60	600	125	0.08	0.02	4	0.060	Th-1A
KP400-**	400	70	1200~1800	4800	1.1×10^5	1.60	1200	125	0.045	0.01	13	0.200	Th-3C
KP600-**	600	65	1200~1800	7200	2.6×10^5	1.65	1500	125	0.04	0.008	15	0.260	Th-5C
KP800-**	800	70	1200~1800	9600	4.6×10^5	1.60	1500	125	0.039	0.008	15	0.260	Th-5C
KP1000-**	1000	70	1200~1800	12000	7.2×10^5	1.45	1500	125	0.03	0.006	20	0.330	Th-7C
KP1200-**	1200	70	1200~1800	14400	10.0×10^5	1.60	3000	125	0.022	0.005	25	0.460	Th-8C
KP1500-**	1500	70	1200~1800	18000	1.6×10^6	1.55	3000	125	0.018	0.005	27	0.593	Th-9C
KP1800-**	1800	70	1200~1800	21600	2.3×10^6	1.50	3000	125	0.015	0.0045	30	0.720	Th-10C
KP2500-**	2500	70	1200~1800	30000	4.5×10^6	1.45	3000	125	0.0125	0.004	33	0.850	Th-11C
KP3000-**	3000	70	1200~1800	36000	6.5×10^6	1.40	3000	125	0.01	0.003	35	1.100	Th-13C
KP4000-**	4000	65	1200~1800	48000	11.5×10^6	1.35	3000	125	0.008	0.002	60	1.400	Th-15C
KP6000-**	6000	65	1200~1800	72000	26.0×10^6	1.30	5000	125	0.006	0.0015	80	1.900	Th-16C
电压至 2400V(Up to 2400V)													
KP100-**	500	70	2000~2400	7000	2.5×10^5	1.80	1500	125	0.039	0.008	15	0.260	Th-5C
KP200-**	500	70	2000~2400	7000	2.5×10^5	1.80	1500	125	0.039	0.008	15	0.260	Th-5C
KP300-**	500	70	2000~2400	7000	2.5×10^5	1.80	1500	125	0.039	0.008	15	0.260	Th-5C
KP500-**	500	70	2000~2400	7000	2.5×10^5	1.80	1500	125	0.039	0.008	15	0.260	Th-5C
KP800-**	800	70	2000~2400	11200	6.3×10^5	1.80	2400	125	0.03	0.006	20	0.330	Th-7C
KP1000-**	1000	70	2000~2400	14000	7.2×10^5	1.80	3000	125	0.022	0.005	25	0.460	Th-8C
KP1200-**	1200	70	2000~2400	14400	10.0×10^5	1.80	3000	125	0.02	0.005	27	0.500	Th-8C
KP1500-**	1500	70	2000~2400	18000	1.6×10^6	1.70	3000	125	0.015	0.0045	30	0.720	Th-10C
KP2100-**	2100	70	2000~2400	24000	2.9×10^6	1.60	3000	125	0.0125	0.004	33	0.850	Th-11C
KP3000-**	3000	65	2000~2400	36000	6.5×10^6	1.45	3000	125	0.01	0.003	35	1.100	Th-13C
KP5700-**	5700	65	2000~2400	68400	23.0×10^6	1.30	5000	125	0.006	0.0015	80	1.900	Th-16C

型号 TYPE	I _{T(AV)} A	TC °C	V _{DRM} /V _{RRM} V	I _{TSM} @T _{VJM} & 10ms A	I ² t A ² s	V _{TM} @I _T &T _J =25°C		T _{JM} °C	R _{jc} °C/W	R _{cs} °C/W	F KN	m Kg	外形 Outline
						V	A						
KP100-**	500	70	2600~3200	7000	2.5x10 ⁵	2.15	1500	125	0.039	0.008	15	0.260	Th-5C
KP200-**	500	70	2600~3200	7000	2.5x10 ⁵	2.15	1500	125	0.039	0.008	15	0.260	Th-5C
KP300-**	500	70	2600~3200	7000	2.5x10 ⁵	2.15	1500	125	0.039	0.008	15	0.260	Th-5C
KP500-**	500	70	2600~3200	7000	2.5x10 ⁵	2.15	1500	125	0.039	0.008	15	0.260	Th-5C
KP1000-**	1000	70	2600~3200	12000	7.2x10 ⁵	2.10	2500	125	0.022	0.005	25	0.460	Th-8C
KP1200-**	1200	70	2600~3200	14400	1.0x10 ⁶	2.00	3000	125	0.018	0.005	27	0.593	Th-9C
KP1700-**	1700	70	2600~3200	20400	2.1x10 ⁶	1.95	3000	125	0.015	0.0045	30	0.720	Th-10C
KP2000-**	2000	70	2600~3200	24000	2.9x10 ⁶	1.85	3000	125	0.0125	0.004	33	0.850	Th-11C
KP2500-**	2500	70	2600~3200	25200	3.2x10 ⁶	1.75	3000	125	0.011	0.003	35	1.500	Th-13D
KP3700-**	3700	65	2600~3200	44400	9.9x10 ⁶	1.65	3000	125	0.008	0.002	60	1.990	Th-15D
KP4500-**	4500	65	2600~3200	54000	1.5x10 ⁷	1.65	5000	125	0.006	0.0015	80	1.900	Th-16C
KP100-**	480	70	3600~4200	5760	1.7x10 ⁵	2.40	1200	125	0.039	0.008	15	0.260	Th-5C
KP200-**	480	70	3600~4200	5760	1.7x10 ⁵	2.40	1200	125	0.039	0.008	15	0.260	Th-5C
KP300-**	480	70	3600~4200	5760	1.7x10 ⁵	2.40	1200	125	0.039	0.008	15	0.260	Th-5C
KP480-**	480	70	3600~4200	5760	1.7x10 ⁵	2.40	1200	125	0.039	0.008	15	0.260	Th-5C
KP1000-**	1000	70	3600~4200	12000	7.2x10 ⁵	2.45	2500	125	0.022	0.005	25	0.460	Th-8C
KP1200-**	1200	70	3600~4200	14400	1.0x10 ⁶	2.40	3000	125	0.016	0.005	28	0.650	Th-9C
KP1500-**	1500	70	3600~4200	18000	1.6x10 ⁶	2.50	3000	125	0.015	0.0045	30	0.720	Th-10C
KP1900-**	1900	70	3600~4200	22800	2.6x10 ⁶	2.30	3000	125	0.0125	0.004	33	0.850	Th-11C
KP2100-**	2100	65	3600~4200	24000	2.9x10 ⁶	2.20	3000	125	0.011	0.003	35	1.500	Th-13D
KP3000-**	3000	70	3600~4200	36000	6.5x10 ⁶	1.70	3000	125	0.008	0.002	60	1.990	Th-15D
KP3800-**	3800	70	3600~4200	45600	1.0x10 ⁷	1.90	5000	125	0.006	0.0015	80	1.900	Th-16C



【备注：YC 系列执行美系工艺标准，为较高要求用户设计，具有更加卓越的性能】

【Remark: YC series is designed for customers with higher requirements, and has better performances.】

型号	$I_{T(AV)}$	TC	V_{DRM}/V_{RRM}	$I_{TSM} @T_{VJIM} \& 10ms$	I^2t	$V_{TM} @I_r \& T_j = 25^\circ C$			T_{jm}	R_{jc}	R_{cs}	F	m	外形
TYPE	A	$^\circ C$	V	A	A^2s	V	A	$^\circ C$	$^\circ C$	$^\circ C/W$	$^\circ C/W$	KN	Kg	Outline
电压至 1600V(Up to 1600V)														
YC380	250	70	500~1600	3500	5.0×10^4	2.85	1500	25	125	0.080	0.020	4	0.06	Th-1A
YC430	680	65	500~1600	8000	2.65×10^5	2.20	2000	25	125	0.054	0.010	10	0.08	Th-2A
YC440	900	65	500~1600	12000	7.0×10^5	1.65	3000	25	125	0.039	0.008	15	0.26	Th-5C
YC450	1640	65	500~1600	26000	3.4×10^6	1.40	3000	25	125	0.022	0.005	25	0.46	Th-8C
电压至 2200V(Up to 2200V)														
YC501	550	70	1000~1700	8000	2.65×10^5	1.53	1000	25	125	0.045	0.010	13	0.20	Th-3C
YC431	600	70	1000~2000	8000	2.65×10^5	2.30	2000	25	125	0.054	0.010	10	0.08	Th-2A
YC441	750	70	1400~2200	11000	5.0×10^5	2.00	3000	25	125	0.039	0.008	15	0.26	Th-5C
YC451	1500	65	1400~2000	21000	2.2×10^6	1.65	3000	25	125	0.022	0.005	25	0.46	Th-8C
YC701	1300	70	1400~2000	20000	2.0×10^6	1.75	3000	25	125	0.022	0.005	25	0.46	Th-8C
YC781	2500	65	1400~2100	41500	8.6×10^6	1.20	2000	25	125	0.011	0.003	35	1.50	Th-13D
电压至 3200V(Up to 3200V)														
YC602	600	70	1700~2600	10000	5.0×10^5	1.90	1000	125	125	0.039	0.008	15	0.26	Th-5C
YC702	1000	70	2400~3200	15000	1.1×10^6	2.26	3000	25	125	0.022	0.005	25	0.46	Th-8C
YC782	2300	70	2400~3000	32000	5.0×10^6	1.35	2000	25	125	0.011	0.003	35	1.50	Th-13D
电压至 4500V(Up to 4500V)														
YC604	400	70	3800~4500	5100	1.3×10^5	2.10	500	125	125	0.039	0.008	15	0.26	Th-5C
STD122	950	70	3500~4400	14700	1.08×10^6	1.60	1000	125	125	0.022	0.005	25	0.46	Th-8C
YC784	1650	70	3600~4400	24000	2.88×10^6	1.85	2000	25	125	0.011	0.003	35	1.50	Th-13D

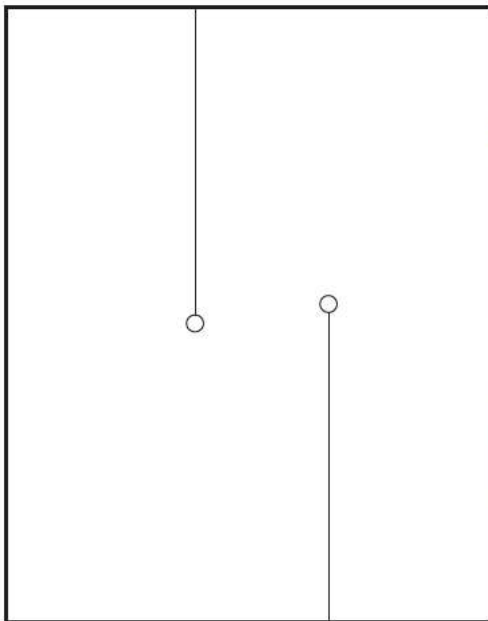

特点

- 全扩散结构
- 分布门极设计
- 优良的动态特性
- 快速开关性能
- 开关损耗

Features:

- All Diffused Structure
- Distributed gate design
- Excellent dynamic performance
- Fast switching performance
- Low switching loss

应用领域

- 逆变器
- 斩波器
- 感应加热
- 各种类型的强迫换流器

Applications:

- Inverter
- Chopper
- Induction heating
- All kinds of forced converter



型号	I _{T(AV)}	T _C	V _{DRM} /V _{RRM}	I _{TSM} @T _{VJM} & 10ms	I ² t	V _{TM} @I _T &T _J =25°C			T _{JM}	R _{jc}	R _{cs}	F	m	外形
						V	A	°C						
TYPE	A	°C	V	A	A ² s	V	A	°C	°C	°C/W	°C/W	KN	Kg	Outline
电压至 1400V(Up to 1400V)														
KK200-**	200	55	1200~1400	2800	3.9x10 ⁴	2.20	640	20	125	0.0600	0.0100	10	0.08	Th-2A
KK500-**	500	55	1200~1400	7500	2.8x10 ⁵	2.00	1570	20	125	0.0390	0.0080	15	0.26	Th-5C
KK800-**	800	55	1200~1400	12000	7.2x10 ⁵	2.00	2400	20	125	0.0300	0.0060	20	0.33	Th-7C
KK1000-**	1000	55	1200~1400	15000	1.1x10 ⁶	2.00	3000	20	125	0.0220	0.0050	25	0.46	Th-8C
KK1200-**	1200	55	1200~1400	18000	1.6x10 ⁶	2.00	3000	20	125	0.0200	0.0050	27	0.5	Th-8C
KK1500-**	1500	55	1200~1400	22500	2.5x10 ⁶	1.90	3000	20	125	0.0160	0.0045	28	0.65	Th-10C
KK1800-**	1800	55	1200~1400	25200	3.2x10 ⁶	1.90	3000	20	125	0.0150	0.0045	30	0.72	Th-11C
KK2400-**	2400	55	1200~1400	33600	5.6x10 ⁶	1.70	3000	22	125	0.0120	0.0040	33	0.72	Th-11C
KK3000-**	3000	55	1200~1400	42000	8.8x10 ⁶	1.60	3000	22	125	0.0100	0.0030	35	0.72	Th-13C
电压至 2000V(Up to 2000V)														
KK500-**	500	55	1600~2000	7000	2.5x10 ⁵	2.50	1570	30	125	0.0390	0.0080	15	0.26	Th-5C
KK800-**	800	55	1600~2000	11200	6.3x10 ⁵	2.60	2400	30	125	0.0300	0.0060	20	0.33	Th-7C
KK1000-**	1000	55	1600~2000	14000	9.8x10 ⁵	2.40	3000	30	125	0.0220	0.0050	25	0.46	Th-8C
KK1200-**	1200	55	1600~2000	16800	1.4x10 ⁶	2.30	3000	30	125	0.0200	0.0050	27	0.5	Th-8C
KK1500-**	1500	55	1600~2000	21000	2.2x10 ⁶	2.20	3000	30	125	0.0160	0.0050	28	0.65	Th-9C
KK1800-**	1800	55	1600~2000	25200	3.2x10 ⁶	2.10	3000	35	125	0.0150	0.0045	30	0.72	Th-11C
KK2000-**	2000	55	1600~2000	28000	3.9x10 ⁶	2.00	3000	35	125	0.0125	0.0040	33	0.85	Th-11C
KK2700-**	2700	55	1600~2000	37800	7.1x10 ⁶	1.90	3000	40	125	0.0100	0.0030	35	1.1	Th-13C
KK3600-**	3600	55	1600~2000	50400	12.5x10 ⁶	1.40	3000	40	125	0.0080	0.0020	60	1.3	T14C
电压至 3000V(Up to 3000V)														
KK1000-**	1000	55	2500~3000	12000	7.2x10 ⁵	2.90	3000	55	125	0.0220	0.0050	25	0.46	Th-8C
KK1200-**	1200	55	2500~3000	14400	1.0x10 ⁶	2.80	3000	55	125	0.0200	0.0050	27	0.5	Th-8C
KK1500-**	1500	55	2500~3000	18500	1.7x10 ⁶	2.70	3000	60	125	0.0160	0.0050	28	0.65	Th-9C
KK1800-**	1800	55	2500~3000	21600	2.3x10 ⁶	2.60	3000	60	125	0.0150	0.0045	30	0.72	Th-11C
KK2000-**	2000	55	2500~3000	24000	2.9x10 ⁶	2.40	3000	60	125	0.0125	0.0040	33	0.85	Th-11C
KK2500-**	2500	55	2500~3000	30000	4.5x10 ⁶	2.20	3000	60	125	0.0100	0.0030	35	1.1	Th-13C
KK3000-**	3000	55	2500~3000	36000	6.5x10 ⁶	1.90	3000	60	125	0.0080	0.0020	60	1.4	Th-15C
KK4000-**	4000	55	2500~3000	48000	1.2x10 ⁷	1.80	3000	60	125	0.0060	0.0015	80	1.9	Th-16D
电压至 3500V(Up to 3500V)														
KK1800-**	1800	55	3200~3500	21600	2.3x10 ⁶	2.90	3000	80	125	0.0100	0.0030	35	1.1	Th-13C
KK2500-**	2500	55	3200~3500	30000	4.5x10 ⁶	2.50	3000	80	125	0.0080	0.0020	60	1.4	Th-15C
电压至 4500V(Up to 4500V)														
KK3708-**	3708	55	4500	50000	1.3x10 ⁷	2.10	4000	250	125	0.0060	0.0015	80	1.9	Th-16D

【备注：YC 系列执行美系工艺标准，为较高要求用户设计，具有更加卓越的性能】

【Remark: YC series is designed for customers with higher requirements, and has better performances.】

型号	$I_{T(AV)}$	TC	V_{DRM}/V_{RRM}	$I_{TSM} @ T_{VJIM} & 10ms$	I^2t	$V_{TM} @ I_T & T_J = 25^\circ C$		t_q	T_{jm}	R_{jc}	R_{cs}	F	m	外形
TYPE	A	$^\circ C$	V	A	A^2s	V	A	μs	$^\circ C$	$^\circ C/W$	$^\circ C/W$	KN	Kg	Outline
电压至 1600V(Up to 1600V)														
YC476	380	55	1200~1600	5320	1.4×10^5	2.90	1500	30	125	0.054	0.010	10	0.08	Th-2A
YC448	700	55	1200~1600	8400	3.5×10^5	2.90	2000	35	125	0.039	0.008	15	0.26	Th-5C
电压至 2000V(Up to 2000V)														
YC712	1000	55	1600~2000	14000	9.8×10^5	2.20	3000	55	125	0.022	0.005	25	0.46	Th-8C
YC770	2619	55	1600~2000	31400	4.9×10^6	1.55	2000	70	125	0.011	0.003	35	1.5	Th-13D

» 高频晶闸管 | High Frequency Thyristo

特点

- 全扩散结构
- 分布门极设计
- 优良的动态特性
- 快速开关性能
- 开关损耗小

Features:

- All Diffused Structure
- Distributed gate design
- Excellent dynamic performance
- Fast switching performance
- Low switching loss

应用领域

- 机车牵引与传动
- 高压直流输电
- 高压无功功率因素补偿
- 大电流电

Applications:

- Traction and transmission
- HVDC
- SVC
- High current power suppl



型号	$I_{T(AV)}$	TC	V_{DRM}/V_{RRM}	$I_{TSM} @ T_{VJIM} & 10ms$	I^2t	$V_{TM} @ I_T & T_J = 25^\circ C$		t_q	T_{jm}	R_{jc}	R_{cs}	F	m	外形
TYPE	A	$^\circ C$	V	A	A^2s	V	A	μs	$^\circ C$	$^\circ C/W$	$^\circ C/W$	KN	Kg	Outline
电压至 1600V(Up to 1600V)														
YC476	380	55	1200~1600	5320	1.4×10^5	2.90	1500	30	125	0.054	0.010	10	0.08	Th-2A
YC448	700	55	1200~1600	8400	3.5×10^5	2.90	2000	35	125	0.039	0.008	15	0.26	Th-5C
电压至 2000V(Up to 2000V)														
YC712	1000	55	1600~2000	14000	9.8×10^5	2.20	3000	55	125	0.022	0.005	25	0.46	Th-8C
YC770	2619	55	1600~2000	31400	4.9×10^6	1.55	2000	70	125	0.011	0.003	35	1.5	Th-13D

特点

- 扩散结
- 平板型陶瓷管壳封装
- 双面冷却, 通态压降

Features:

- Diffused junction
- Capsule type ceramic package
- Double side cooling, low forward voltage

应用领域

- 机车牵引与传动
- 高压直流输电
- 高压无功功率因素补偿
- 大电流电源、电机软启动
- 电机励磁、感应加热

Applications:

- Traction and transmission
- HVDC, SVC
- High current power supply
- Soft-starter, Motor excitation
- Induction heating



型号	$I_{F(AV)}$	T_c	V_{RRM}	$I_{FSM} @T_{vjM}$ & $10ms$	I^2t	V_{FM} @ I_F & $T_J=25^\circ C$		T_{jm}	R_{jc}	R_{cs}	F	m	外形
TYPE	A	$^\circ C$	V	A	A^2s	V	A	$^\circ C$	$^\circ C/W$	$^\circ C/W$	KN	Kg	Outline
电压至 1600V(Up to 1600V)													
ZP400-**	400	100	600~1600	4400	9.7×10^4	1.35	900	175	0.0800	0.0200	4	0.06	D1A
ZP800-**	800	100	600~1600	8800	38.0×10^4	1.30	1500	175	0.0540	0.0100	10	0.08	D2A
ZP1300-**	1300	100	600~1600	14300	1.0×10^6	1.25	1500	175	0.0390	0.0080	15	0.26	D5C
ZP2500-**	2500	100	600~1600	27500	3.8×10^6	1.35	3000	175	0.0220	0.0050	25	0.46	D8C
ZP3200-**	3200	100	600~1600	35200	6.2×10^6	1.30	3000	175	0.0150	0.0045	30	0.72	D10C
ZP4600-**	4600	90	600~1600	50600	13.0×10^6	1.15	3000	175	0.0125	0.0040	33	0.85	D11C
ZP6000-**	6000	90	600~1600	66000	21.0×10^6	1.15	3000	175	0.0100	0.0030	35	1.10	D13C
电压至 2400V(Up to 2400V)													
ZP300-**	300	100	1800~2400	3600	6.5×10^4	1.40	900	175	0.0800	0.0200	4	0.06	D1A
ZP600-**	600	100	1800~2400	7200	26.0×10^4	1.40	1500	175	0.0540	0.0100	10	0.08	D2A
ZP1100-**	1100	100	1800~2400	13200	87.0×10^4	1.30	1500	175	0.0390	0.0080	15	0.26	D5C
ZP2000-**	2000	100	1800~2400	24000	2.9×10^6	1.45	3000	175	0.0220	0.0050	25	0.46	D8C
ZP2500-**	2500	100	1800~2400	30000	4.5×10^6	1.40	3000	175	0.0150	0.0045	30	0.72	D10C
ZP3400-**	3400	100	1800~2400	40800	8.3×10^6	1.25	3000	175	0.0125	0.0040	33	0.85	D11C
ZP4400-**	4400	100	1800~2400	52800	14.0×10^6	1.20	3000	175	0.0100	0.0030	35	1.10	D13C
ZP6500-**	6500	90	1800~2400	78000	3.0×10^7	1.25	5000	175	0.0080	0.0020	60	1.40	D15C
ZP7500-**	7500	100	1800~2400	90000	4.0×10^7	1.15	5000	175	0.0060	0.0015	80	1.90	D16C
电压至 3500V(Up to 3500V)													
ZP200-**	200	100	2500~3500	2800	4.0×10^4	1.55	600	150	0.0800	0.0200	4	0.06	D1A
ZP700-**	700	100	2500~3500	9800	48.0×10^4	1.95	1500	175	0.0540	0.0100	10	0.08	D2A
ZP800-**	800	90	2500~3500	11200	62.0×10^4	1.70	1500	150	0.0390	0.0080	15	0.26	D5C
ZP1350-**	1350	90	2500~3500	18900	1.7×10^6	1.60	3000	150	0.0220	0.0050	25	0.46	D8C
ZP2000-**	2000	90	2500~3500	28000	4.0×10^6	1.55	3000	150	0.0150	0.0045	30	0.72	D10C
ZP2900-**	2900	90	2500~3500	40600	8.0×10^6	1.50	3000	160	0.0125	0.0040	33	0.85	D11C
ZP3500-**	3500	90	2500~3500	49000	12.0×10^6	1.35	3000	160	0.0100	0.0030	35	1.10	D13C
ZP5000-**	5000	100	2500~3500	70000	2.4×10^7	1.35	5000	175	0.0080	0.0020	60	1.40	D15C
ZP5800-**	5800	90	2500~3500	81200	3.3×10^7	1.20	5000	160	0.0060	0.0015	80	1.90	D16C

型号 TYPE	I _{F(AV)} A	T _c °C	V _{RRM} V	I _{FSM} @T _{VJIM} & 10ms A	I ² t A ² s	V _{FM} @I _F &T _J =25°C			T _{jm} °C	R _{jc} °C/W	R _{cs} °C/W	F KN	m Kg	外形 Outline
						V	A	°C						
电压至 4500V(Up to 4500V)														
ZP500-**	500	100	3600~4500	7500	28.0×10 ⁴	2.10	1500	150	0.0540	0.0100	10	0.08	D2A	
ZP640-**	640	100	3600~4500	9600	46.0×10 ⁴	1.90	1500	150	0.0390	0.0080	15	0.26	D5C	
ZP1200-**	1200	100	3600~4500	18000	1.6×10 ⁶	2.00	3000	150	0.0220	0.0050	25	0.46	D8C	
ZP1350-**	1350	100	3600~4500	20250	2.0×10 ⁶	1.80	3000	150	0.0150	0.0045	30	0.72	D10C	
ZP1900-**	1900	100	3600~4500	28500	4.0×10 ⁶	1.70	3000	150	0.0125	0.0040	33	0.85	D11C	
ZP2500-**	2500	100	3600~4500	37500	7.0×10 ⁶	1.60	3000	150	0.0100	0.0030	35	1.10	D13C	
ZP4000-**	4000	100	3600~4500	60000	1.8×10 ⁷	1.45	5000	160	0.0080	0.0020	60	1.40	D15C	
ZP5200-**	5200	90	3600~4500	78000	3.0×10 ⁷	1.35	5000	150	0.0060	0.0015	80	1.90	D16C	
电压至 5200V(Up to 5200V)														
ZP2100-**	2100	100	4600~5200	31500	5.0×10 ⁶	1.50	3000	150	0.0100	0.0030	35	1.10	D13C	
ZP3400-**	3400	90	4600~5200	51000	1.3×10 ⁷	1.35	5000	150	0.0080	0.0020	60	1.40	D15C	
电压至 6500V(Up to 6500V)														
ZP2400-**	2400	100	5400~6500	36000	6.5×10 ⁶	1.50	5000	150	0.0080	0.0020	60	1.40	D15C	
ZP3500-**	3500	100	5400~6500	52500	1.4×10 ⁷	1.45	5000	150	0.0060	0.0015	80	1.90	D16C	
电压至 7200V(Up to 7200V)														
ZP500-**	500	100	6600~7200	7500	28×10 ⁴	2.00	1500	150	0.0390	0.0080	15	0.26	D5C	
ZP960-**	960	100	6600~7200	14400	1.0×10 ⁶	1.75	1500	150	0.0220	0.0050	25	0.46	D8C	

» YA系列高结温标准二极管 | YA Series Standard Diode With High Junction Temperature

【备注: YC 系列执行美系工艺标准, 为较高要求用户设计, 具有更加卓越的性能】

【Remark: YC series is designed for customers with higher requirements, and has better performances.】

型号 TYPE	I _{F(AV)} A	T _c °C	V _{RRM} V	I _{FSM} @T _{VJIM} & 10ms A	I ² t A ² s	V _{FM} @I _F &T _J =25°C			T _{jm} °C	R _{jc} °C/W	R _{cs} °C/W	F KN	m Kg	外形 Outline
						V	A	°C						
电压至 2200V(Up to 2200V)														
YA640	1500	95	1200~2200	15000	1.12×10 ⁶	1.090	1000	160	185	0.039	0.008	15	0.26	D5C
YA740	2400	100	1400~2000	30000	4.5×10 ⁶	0.860	1000	160	185	0.022	0.005	25	0.46	D8C
电压至 2600V(Up to 2600V)														
YA540	1000	100	2000~2400	11500	6.6×10 ⁵	1.080	1000	160	185	0.045	0.010	13	0.2	D3C
YA641	1500	90	1800~2600	15000	1.12×10 ⁶	0.990	1000	160	185	0.039	0.008	15	0.26	D5C
YA800	4400	90	1800~2600	55000	1.5×10 ⁷	0.865	2000	160	185	0.010	0.003	35	1.1	D13C
电压至 3200V(Up to 3200V)														
YA750	1800	100	2500~3200	22000	2.4×10 ⁶	0.960	1000	160	175	0.022	0.005	25	0.46	D8C
YA801	3900	90	2800~3200	57000	1.6×10 ⁷	1.050	2000	150	175	0.010	0.003	35	1.1	D13C
电压至 4600V(Up to 4600V)														
YA643	1000	85	3500~4400	10000	5×10 ⁵	1.400	1000	160	170	0.039	0.008	15	0.26	D5C
YA780	1500	100	3500~4600	18000	1.6×10 ⁶	1.150	1000	160	170	0.022	0.005	25	0.46	D8C
YA880	2900	100	3800~4500	36000	6.5×10 ⁶	1.150	2000	160	170	0.010	0.003	35	1.1	D13C

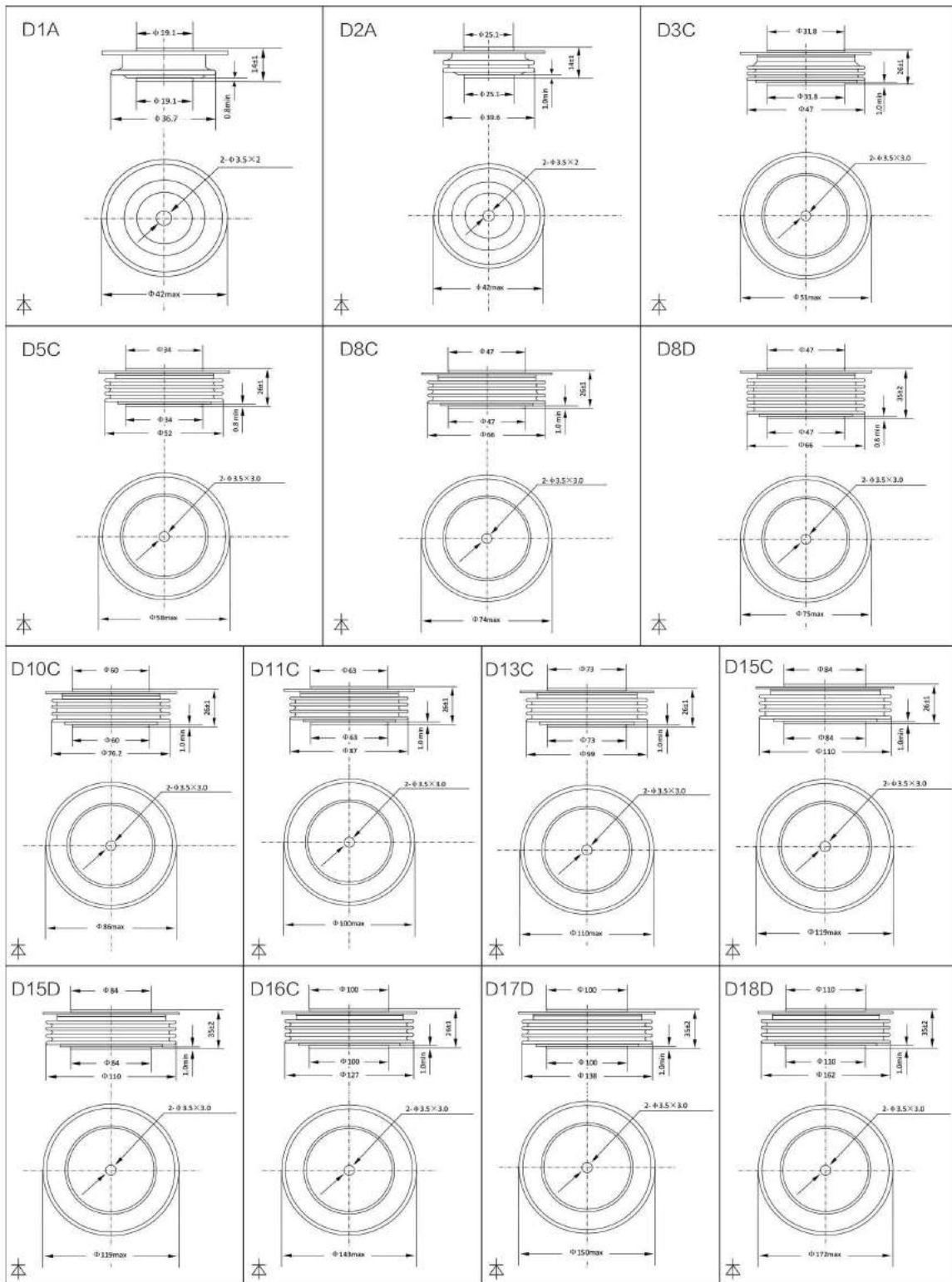

注：未标注数量单位的统一为毫米

Remark: All dimensions shown in mm unless stated otherwise

Th-1A

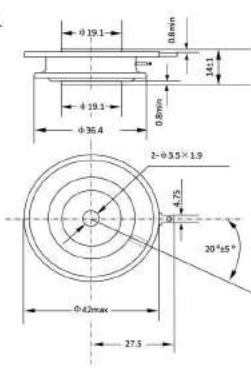

本

Th-2A

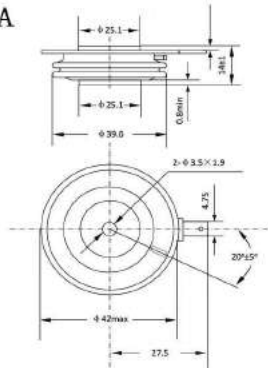

本

Th-3C

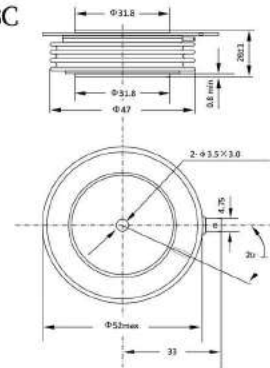

本

Th-5C

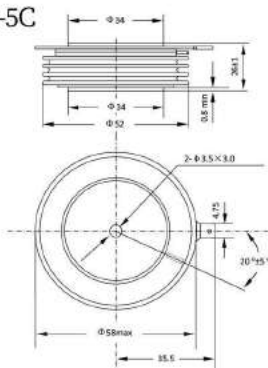

本

Th-5D

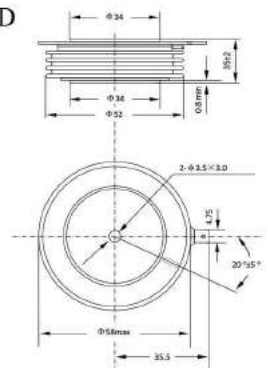

本

Th-7C

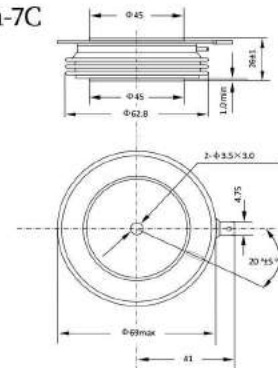

本

Th-8C

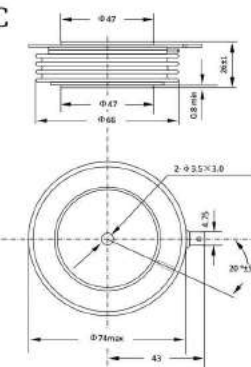

本

Th-8D

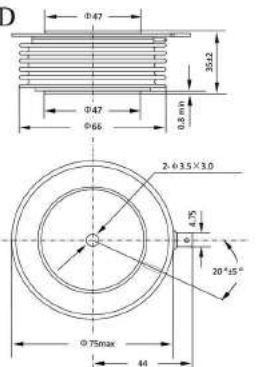

本

Th-9C

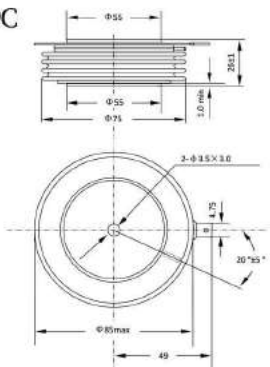

本

Th-10C

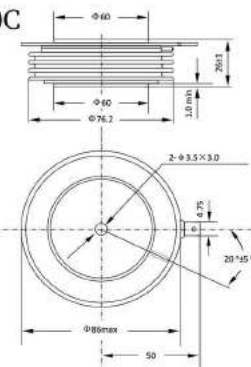

本

Th-11C

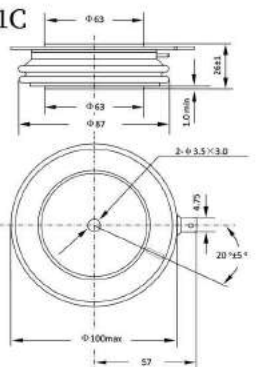

本

Th-13C

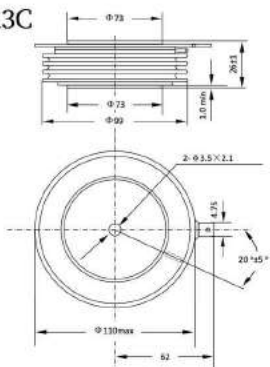

本

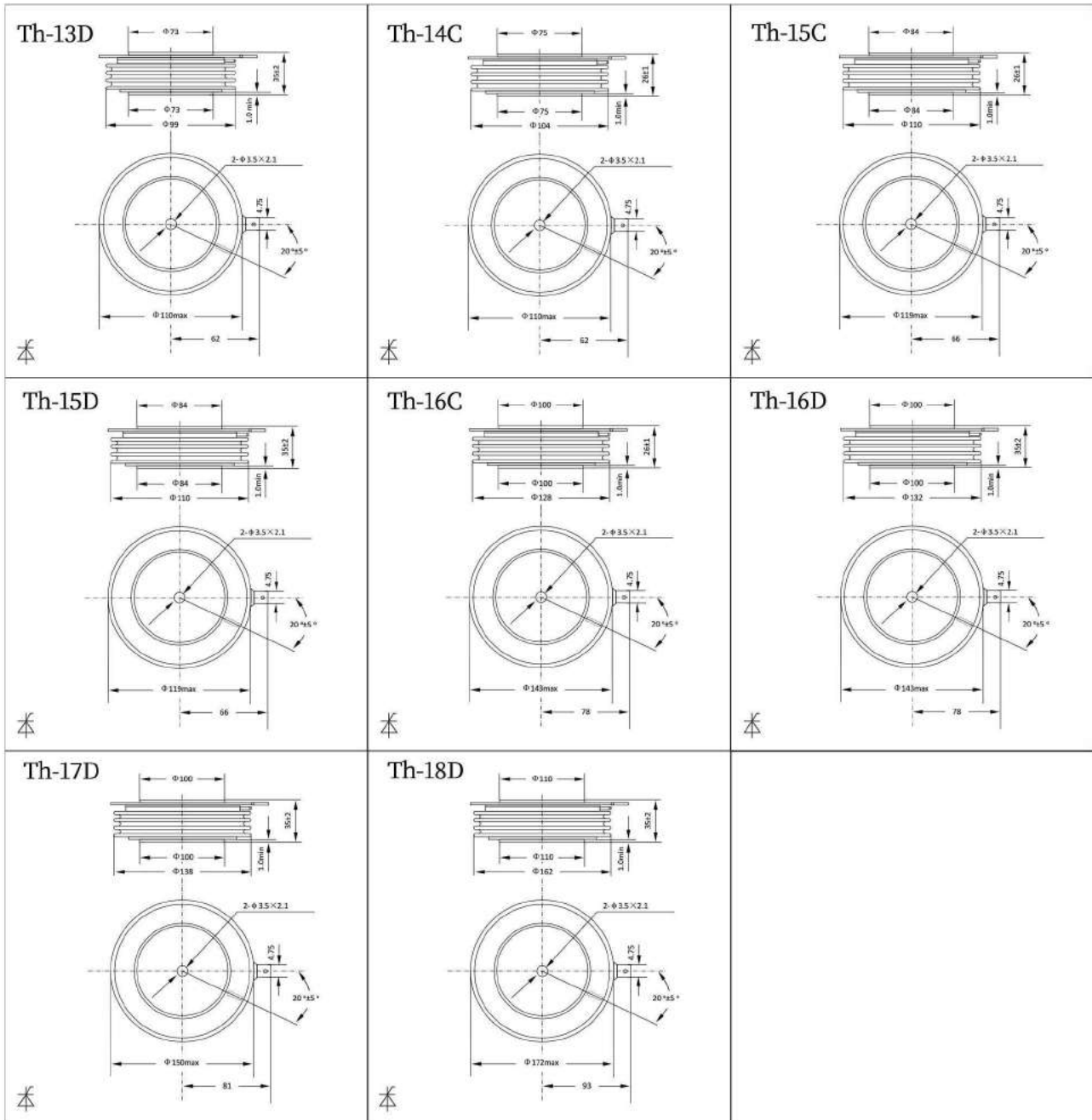

注：· 门极阴极引线长 400mm · 未标注数量单位的统一为毫米

Remark: · The standard length of gate and cathode leads is 400mm · All dimensions shown in mm unless stated otherwise

特点

- 超大电流能力
- 极低的通态电压
- 非常低的热电阻
- 高可靠性
- 适用于中频或高频小

Features:

- High forward current capability
- Low forward voltage
- Minimum thermal resistance
- High operational reliability
- Uitable for intermediate or high frequency



应用领域

- 逆变型电阻焊整流装

Applications:

- Inverter resistance welding rectifying device

型号	$I_{F(AV)}$	T_C	V_{RRM}	I_{FSM} @ T_{VJM} & 10ms	I^2t	V_{FM} @ I_F & $T_J=25^\circ C$		T_{jm}	R_{jc}	F	m	外形
TYPE	A	$^\circ C$	V	A	A^2s	V	A	$^\circ C$	$^\circ C/W$	KN	Kg	Outline
电压至 400V(Up to 400V)												
ZW7100-**	7100	85	200~400	55000	1.5×10^7	1.05	5000	170	0.0100	24	0.140	ZW1
ZW10500-**	10500	85	200~400	70000	2.4×10^7	1.01	5000	180	0.0050	32	0.460	ZW2
ZW12000-**	12000	85	200~400	85000	3.6×10^7	0.99	5000	170	0.0060	35	0.205	ZW3
ZW13500-**	13500	85	200~400	85000	3.6×10^7	0.97	5000	180	0.0039	35	0.140	ZW4
ZW16000-**	16000	85	200~400	120000	7.2×10^7	0.92	5000	170	0.0040	37	0.570	ZW5
ZW18000-**	18000	85	200~400	135000	9.1×10^7	0.90	5000	170	0.0040	40	0.580	ZW5

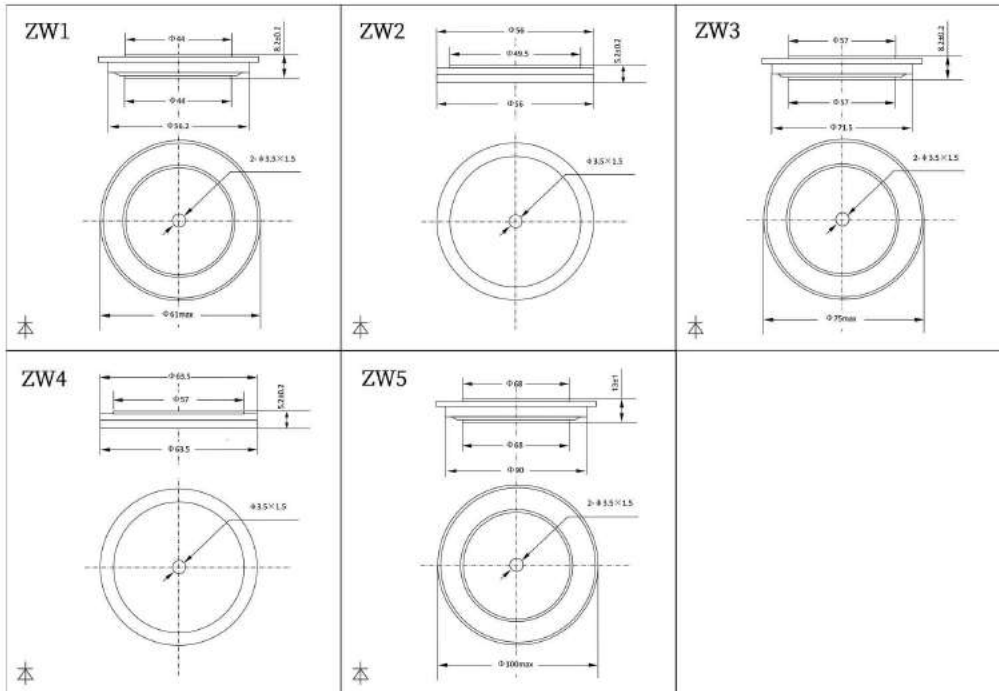
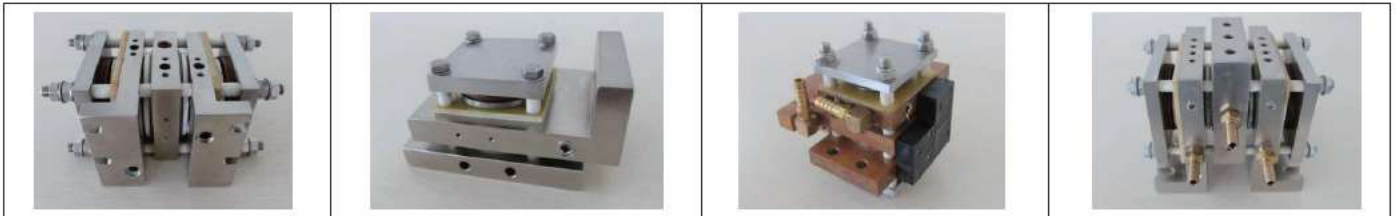

特点

- 芯片与底板电气绝缘
- 国际标准封装
- 全压接结构
- 优良的温度特性和功率循环能力
- 安装简单,使用维修方便·体积小,重量

Features:

- Electric insulation between chips and baseplate
- International standard packaging
- Compress structure
- Excellent power cycling capacity
- Easy to install and maintain ·Small size, less weight

应用领域

- 交直流电机控制
- 各种整流电源
- 工业加热控制
- 调光、无触点开关
- 电机软起动
- 静止无功补偿
- 电焊机、变频器
- UPS 电源、电池充放电

Applications:

- AC/DC motor control
- Various rectifier power supply
- Industrial heating control
- Light-dimmer, Contactless switch
- Motor soft start, SVC
- Welding machine
- Frequency converter
- UPS, Battery charge

型号	I _{T(AV)}	V _{DEM/V_{RRM}}	I _{DRM/I_{RRM}}		V _{TM}		I _{GT}	V _{GT}	I _H	dV/dt	V _{ISO}	外形
			V=V _{DRM/V_{RRM}}		25°C							
TYPE	@85°C	V	125°C	25°C	25°C		mA	V	mA	Min	Min	Outline
	A		V	V	V	A						
MTC/MTK/MTA/MTX 1200-2000V 风冷(Air cooling)												
MT*90-**	90	1200-2000	15	1.45	270	30-100	0.8-2.2	20-120	1000	2500	Mo2-20	
MT*110-**	110	1200-2000	15	1.45	330	30-100	0.8-2.2	20-120	1000	2500	Mo2-34	
MT*135-**	135	1200-2000	20	1.45	400	30-100	0.8-2.2	20-120	1000	2500		
MT*160-**	160	1200-2000	20	1.45	480	30-100	0.8-2.2	20-120	1000	2500	Mo2-36	
MT*185-**	185	1200-2000	20	1.45	560	30-100	0.8-2.2	20-120	1000	2500		
MT*200-**	200	1200-2000	20	1.45	600	30-100	0.8-2.2	20-120	1000	2500	Mo4-53	
MT*200-**	200	1200-2000	20	1.45	600	30-100	0.8-2.2	20-120	1000	2500		
MT*250-**	250	1200-2000	20	1.45	750	30-100	0.8-2.2	20-120	1000	2500		
MT*300-**	300	1200-2000	20	1.45	900	30-100	0.8-2.2	20-120	1000	2500	Mo4-63	
MT*350-**	350	1200-2000	35	1.45	1050	30-100	0.8-2.2	20-120	1000	2500		
MT*400-**	400	1200-2000	45	1.45	1200	30-100	0.8-2.2	20-120	1000	2500	Mo4-66	
MT*500-**	500	1200-2000	45	1.45	1500	30-100	0.8-2.2	20-120	1000	2500		
MT*600-**	600	1200-2000	55	1.45	1800	30-100	0.8-2.2	20-120	1000	2500	Mo4-76	
MT*800-**	800	1200-2000	65	1.60	2400	30-100	0.8-2.2	20-120	1000	2500	Mo4-77	
MT*1000-**	1000	1200-2000	65	1.60	3000	30-100	0.8-2.2	20-120	1000	2500	Mo4-77	
MTC/MTK/MTA/MTX 2200-3500V 风冷(Air cooling)												
MT*160-**	160	2200-3500	30	2.20	480	30-100	0.8-2.2	20-120	1000	2500-4000	Mo2-34	
MT*200-**	200	2200-3500	35	1.80	600	30-100	0.8-2.2	20-120	1000	2500-4000	Mo4-53	
MT*250-**	250	2200-3500	35	1.90	750	30-100	0.8-2.2	20-120	1000	2500-4000		
MT*300-**	300	2200-3500	35	1.90	900	30-100	0.8-2.2	20-120	1000	2500-4000		
MT*350-**	350	2200-3500	50	2.00	1050	30-100	0.8-2.2	20-120	1000	2500-4000	Mo4-63	
MT*400-**	400	2200-3500	50	2.10	1200	30-100	0.8-2.2	20-120	1000	2500-4000		
MT*500-**	500	2200-3500	50	2.10	1500	30-100	0.8-2.2	20-120	1000	2500-4000	Mo4-66	
MT*600-**	600	2200-3500	60	2.00	1800	30-100	0.8-2.2	20-120	1000	2500-4000		
MT*800-**	800	2200-3500	70	2.15	2400	30-100	0.8-2.2	20-120	1000	2500-4000	Mo4-76	
MT*1000-**	1000	2200-3500	80	2.20	3000	30-100	0.8-2.2	20-120	1000	2500-4000	M4-77	

备注: *代表连接方式 **代表模块电压

型号	$I_{T(AV)}$	V_{DRM}/V_{RRM}	I_{DRM}/I_{RRM}	V_{TM}			I_{GT}	V_{GT}	I_H	dV/dt	V_{ISO}	外形
			$V=V_{DRM}/V_{RRM}$	25°C			VD=12V			$V_D=2/3V_{DRM}$	50HZ, RMS	
											125°C	
TYPE	@85°C		MAX	MAX	I_{TM}	25°C			Min	Min		
	A	V	V	V	A	mA	V	mA	V/ μ s	V	Outline	
MTC/MTK/MTA/MTX 3600-4500V 风冷(Air cooling)												
MT*160-**	160	≤4500	30	2.40	480	30-100	0.8-2.2	20-120	1000	4000-5000	Mo2-34	
MT*200-**	200	≤4500	35	2.00	600	30-120	0.8-2.2	20-120	1000	4000-5000	Mo4-53	
MT*250-**	250	≤4500	35	2.10	750	30-120	0.8-2.2	20-120	1000	4000-5000		
MT*300-**	300	≤4500	35	2.20	900	30-120	0.8-2.2	20-120	1000	4000-5000		
MT*350-**	350	≤4500	35	2.20	1050	30-120	0.8-2.2	20-120	1000	4000-5000		
MT*400-**	400	≤4500	70	2.50	1200	30-120	0.8-2.2	20-120	1000	4000-5000	Mo4-63	
MT*500-**	500	≤4500	70	2.60	1500	30-120	0.8-2.2	20-120	1000	4000-5000		
MT*600-**	600	≤4500	70	2.50	1800	30-120	0.8-2.2	20-120	1000	4000-5000	Mo4-66	
MT*800-**	800	≤4500	80	2.40	2400	30-120	0.8-2.2	20-120	1000	4000-5000	Mo4-76	
MT*1000-**	1000	≤4500	80	2.50	3000	30-120	0.8-2.2	20-120	1000	4000-5000	Mo4-77	
MTC/MTK/MTA/MTX 1200-2000V 水冷(Water cooling)												
MT*200-**	200	≤4500	35	2.00	600	30-120	0.8-2.2	20-120	1000	4000-5000	Mo4-53-S	
MT*250-**	250	≤4500	35	2.10	750	30-120	0.8-2.2	20-120	1000	4000-5000	Mo4-53-S	
MT*300-**	300	≤4500	35	2.20	900	30-120	0.8-2.2	20-120	1000	4000-5000	Mo4-53-S	
MT*400-**	400	1200-2000	35	1.50	1200	30-100	0.8-2.2	20-120	1000	2500	Mo4-53-S	
MT*500-**	500	1200-2000	45	1.60	1500	30-100	0.8-2.2	20-120	1000	2500	Mo4-63-S	
MT*600-**	600	1200-2000	55	1.50	1800	30-100	0.8-2.2	20-120	1000	2500	Mo4-66-S	
MT*800-**	800	1200-2000	65	1.60	2400	30-100	0.8-2.2	20-120	1000	2500	Mo4-76-S	

备注: *代表连接方式 **代表模块电压



型号 TYPE	$I_{T(AV)}$ @85°C	V_{RRM} V	I_{RRM}	V_{FM}		V_{ISO}	外形 Outline
			$V=V_{REM}$	25°C		50HZ, RMS 2mA, 1min	
			150°C	M_{sx}	I_{FM}	25°C	
A	V	V	V	A	V		
MDC/MDK/MDA 1200-2000V 风冷(Air cooling)							
MD*90-**	90	1200-2000	5	1.30	270	2500	Mo2-20
MD*110-**	110	1200-2000	5	1.30	330	2500	
MD*160-**	160	1200-2000	5	1.30	480	2500	Mo2-34
MD*200-**	200	1200-2000	5	1.30	600	2500	
MD*250-**	250	1200-2000	5	1.30	750	2500	Mo4-53
MD*300-**	300	1200-2000	5	1.30	900	2500	
MD*350-**	350	1200-2000	5	1.30	1050	2500	
MD*400-**	400	1200-2000	10	1.30	1200	2500	Mo4-63
MD*500-**	500	1200-2000	10	1.30	1500	2500	
MD*600-**	600	1200-2000	10	1.30	1800	2500	Mo4-66
MD*800-**	800	1200-2000	10	1.45	2400	2500	Mo4-76
MD*1000-**	1000	1200-2000	10	1.45	3000	2500	
MD*1200-**	1200	1200-2000	10	1.45	3000	2500	Mo4-77
MD*160-**	160	2200-3500	5	1.60	480	2500-4000	Mo2-34
MD*200-**	200	2200-3500	5	1.60	600	2500-4000	Mo4-53
MD*250-**	250	2200-3500	5	1.60	750	2500-4000	
MD*300-**	300	2200-3500	5	1.60	900	2500-4000	
MD*350-**	350	2200-3500	5	1.60	1050	2500-4000	Mo4-63
MD*400-**	400	2200-3500	10	1.65	1200	2500-4000	
MD*500-**	500	2200-3500	10	1.70	1500	2500-4000	Mo4-66
MD*600-**	600	2200-3500	10	1.70	1800	2500-4000	Mo4-76
MD*800-**	800	2200-3500	15	1.70	2400	2500-4000	
MD*1000-**	1000	2200-3500	15	1.75	3000	2500-4000	Mo4-77
MD*1200-**	1200	2200-3500	15	1.75	3000	2500-4000	
MD*160-**	160	3600-4500	10	1.80	480	4000-5000	Mo2-34
MD*200-**	200	3600-4500	10	1.80	600	4000-5000	Mo4-53
MD*250-**	250	3600-4500	15	1.80	750	4000-5000	
MD*300-**	300	3600-4500	15	1.80	900	4000-5000	
MD*350-**	350	3600-4500	15	1.80	1050	4000-5000	Mo4-63
MD*400-**	400	3600-4500	25	1.85	1200	4000-5000	
MD*500-**	500	3600-4500	25	1.90	1500	4000-5000	Mo4-66
MD*600-**	600	3600-4500	35	1.90	1800	4000-5000	Mo4-76
MD*800-**	800	3600-4500	35	1.95	2400	4000-5000	
MD*1000-**	1000	3600-4500	35	2.00	3000	4000-5000	Mo4-77

备注: *代表连接方式 **代表模块电压

型号	$I_{T(AV)}$	V_{RRM}	I_{RFM}	V_{FM}		V_{ISO}	外形
			$V=V_{RRM}$	25°C		50HZ, RMS 2mA, 1min	
TYPE	@85°C	V	150°C	25°C		25°C	Outline
	A		M_{ax}	M_{ax}	I_{FM}	Min	
V							
MDC/MDK/MDA 1200-2000V 水冷(Water cooling)							
MD*400-**	400	1200-2000	10	1.35	1200	2500	Mo4-53-S
MD*500-**	500	1200-2000	10	1.35	1500	2500	Mo4-63-S
MD*600-**	600	1200-2000	10	1.35	1800	2500	Mo4-66-S
MD*800-**	800	1200-2000	10	1.50	2400	2500	Mo4-76-S
MD*1000-**	1000	1200-2000	10	1.50	3000	2500	Mo4-76-S
MD*1200-**	1200	1200-2000	10	1.50	3000	2500	Mo4-77-S

备注: *代表连接方式 **代表模块电压



3

功率半导体模块 Power Module
晶闸管模块 Thyristor Module
整流管模块 Diode Module
晶闸管/整流管混合模块 Thyristor/Diode Module
模块外形图 Outline of Power Module

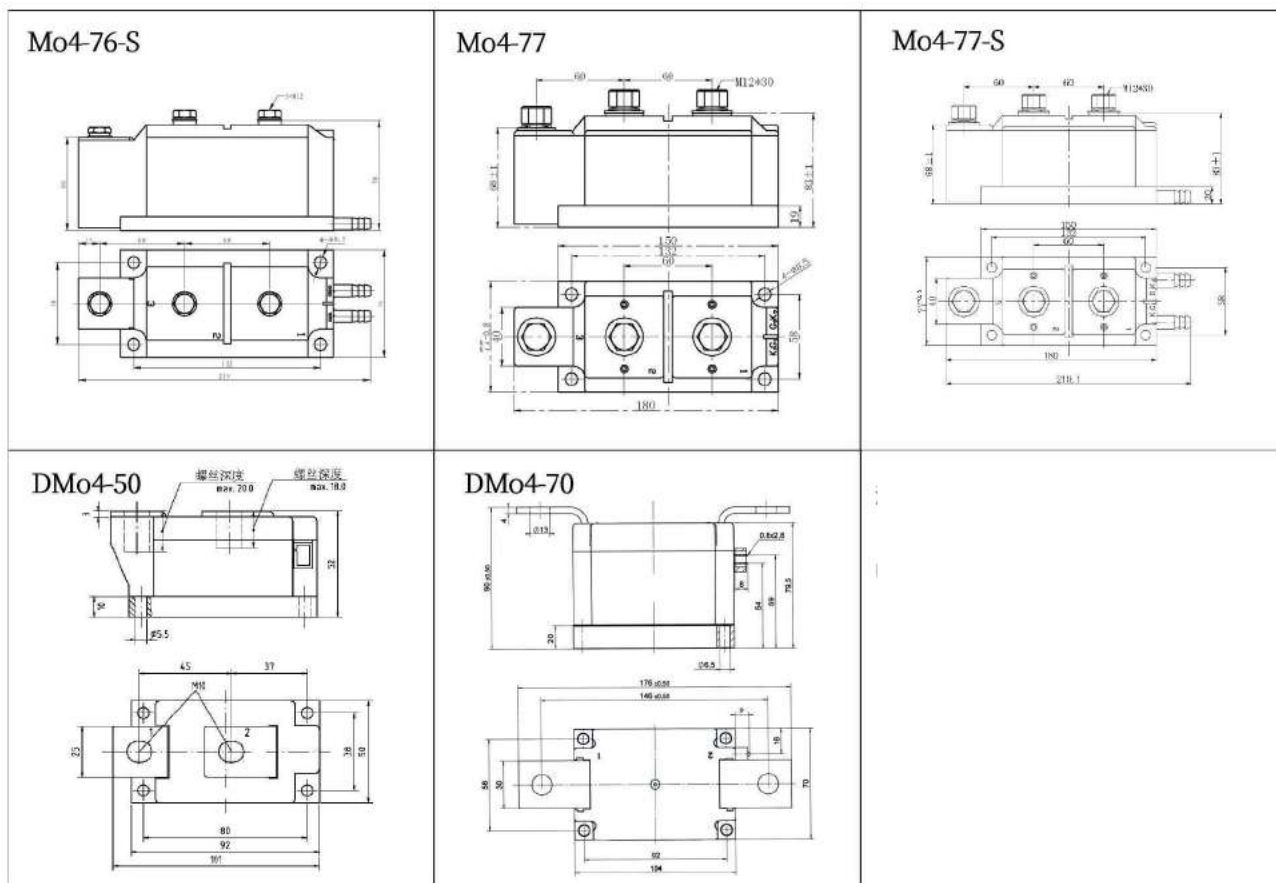

型号	I _{T(AV)}	V _{DRM} /V _{RRM}	I _{DRM} /I _{RRM}		V _{TM}		I _{GT}	V _{GT}	I _H	dV/dt	V _{ISO}	外形			
			V=V _{DRM} /V _{RRM}										VD=12V	V _D =2/3V _{DRM}	50HZ, RMS 2mA, 1min
			125°C		25°C										
TYPE	@85°C		M _{AX}	M _{AX}	I _{TM}	25°C			Min	Min	Outline				
	A	V	V	V	A	mA	V	mA	V/μs	V					
MFC/MFK/MFA/MFX 1200-2000V 风冷(Air cooling)															
MF*90-**	90	1200-2000	15	1.45/1.30	270	30-100	0.8-2.2	20-120	1000	2500	Mo2-20				
MF*110-**	110	1200-2000	15	1.45/1.30	330	30-100	0.8-2.2	20-120	1000	2500					
MF*135-**	135	1200-2000	25	1.45/1.30	400	30-100	0.8-2.2	20-120	1000	2500	Mo2-34				
MF*160-**	160	1200-2000	25	1.45/1.30	480	30-100	0.8-2.2	20-120	1000	2500					
MF*185-**	185	1200-2000	35	1.45/1.30	560	30-100	0.8-2.2	20-120	1000	2500	Mo2-36				
MT*200-**	200	1200-2000	20	1.45/1.30	600	30-100	0.8-2.2	20-120	1000	2500					
MF*200-**	200	1200-2000	20	1.45/1.30	600	30-100	0.8-2.2	20-120	1000	2500	Mo4-53				
MF*250-**	250	1200-2000	20	1.45/1.30	750	30-100	0.8-2.2	20-120	1000	2500					
MF*300-**	300	1200-2000	20	1.45/1.30	900	30-100	0.8-2.2	20-120	1000	2500					
MF*350-**	350	1200-2000	35	1.45/1.30	1050	30-100	0.8-2.2	20-120	1000	2500	Mo4-63				
MF*400-**	400	1200-2000	45	1.45/1.30	1200	30-100	0.8-2.2	20-120	1000	2500					
MF*500-**	500	1200-2000	45	1.45/1.30	1500	30-100	0.8-2.2	20-120	1000	2500	Mo4-66				
MF*600-**	600	1200-2000	55	1.45/1.30	1800	30-100	0.8-2.2	20-120	1000	2500					
MF*800-**	800	1200-2000	65	1.60/1.30	2400	30-100	0.8-2.2	20-120	1000	2500	Mo4-76				
MF*1000-**	1000	1200-2000	65	1.60/1.30	3000	30-100	0.8-2.2	20-120	1000	2500	Mo4-77				
MFC/MFK/MFA/MFX 2200-3500V 风冷(Air cooling)															
MF*160-**	160	2200-3500	30	2.20/2.00	480	30-100	0.8-2.2	20-120	1000	2500-4000	Mo2-34				
MF*200-**	200	2200-3500	35	1.80/1.60	600	30-100	0.8-2.2	20-120	1000	2500-4000	Mo4-53				
MF*250-**	250	2200-3500	35	1.90/1.70	750	30-100	0.8-2.2	20-120	1000	2500-4000					
MF*300-**	300	2200-3500	35	1.90/1.70	900	30-100	0.8-2.2	20-120	1000	2500-4000					
MF*350-**	350	2200-3500	50	2.00/1.80	1050	30-100	0.8-2.2	20-120	1000	2500-4000	Mo4-63				
MF*400-**	400	2200-3500	50	2.10/1.90	1200	30-100	0.8-2.2	20-120	1000	2500-4000					
MF*500-**	500	2200-3500	50	2.10/1.90	1500	30-100	0.8-2.2	20-120	1000	2500-4000	Mo4-66				
MF*600-**	600	2200-3500	60	2.00/1.80	1800	30-100	0.8-2.2	20-120	1000	2500-4000					
MF*800-**	800	2200-3500	70	2.15/1.95	2400	30-100	0.8-2.2	20-120	1000	2500-4000	Mo4-76				
MF*1000-**	1000	2200-3500	80	2.20/2.00	3000	30-100	0.8-2.2	20-120	1000	2500-4000	Mo4-77				
MFC/MFK/MFA/MFX 3600-4500V 风冷(Air cooling)															
MF*160-**	160	3600-4500	30	2.40/2.20	480	30-100	0.8-2.2	20-120	1000	4000-5000	Mo2-34				
MF*200-**	200	3600-4500	35	2.00/1.80	600	30-120	0.8-2.2	20-120	1000	4000-5000	Mo4-53				
MF*250-**	250	3600-4500	35	2.10/1.90	750	30-120	0.8-2.2	20-120	1000	4000-5000					
MF*300-**	300	3600-4500	35	2.20/2.00	900	30-120	0.8-2.2	20-120	1000	4000-5000					
MF*350-**	350	3600-4500	35	2.20/2.00	1050	30-120	0.8-2.2	20-120	1000	4000-5000	Mo4-63				
MF*400-**	400	3600-4500	70	2.50/2.30	1200	30-120	0.8-2.2	20-120	1000	4000-5000					
MF*500-**	500	3600-4500	70	2.60/2.40	1500	30-120	0.8-2.2	20-120	1000	4000-5000	Mo4-66				
MF*600-**	600	3600-4500	70	2.50/2.30	1800	30-120	0.8-2.2	20-120	1000	4000-5000					
MF*800-**	800	3600-4500	80	2.40/2.20	2400	30-120	0.8-2.2	20-120	1000	4000-5000	Mo4-76				
MF*1000-**	1000	3600-4500	80	2.50/2.30	3000	30-120	0.8-2.2	20-120	1000	4000-5000	Mo4-77				

备注:*代表连接方式 **代表模块电压

型号	$I_{T(AV)}$	V_{DRM}/V_{RRM}	I_{DRM}/I_{RRM}	V_{TM}		I_{GT}	V_{GT}	I_H	dV/dt	V_{ISO}	外形
			$V=V_{DRM}/V_{RRM}$	25°C					$V_D=2/3V_{DRM}$	50HZ, RMS 2mA, 1min	
			125°C	MAX	I_{TM}					125°C	
TYPE	@85°C		MAX	MAX	A	25°C		Min	Min	Outline	
	A	V	V	V	A	mA	V	mA	V/ μ S	V	
MFC/MFK/MFA/MFX 1200-2000V 风冷(Air cooling)											
MF*400-**	400	1200-2000	35	1.5/1.30	1200	30-100	0.8-2.2	20-120	1000	2500	Mo4-53-S
MF*500-**	500	1200-2000	45	1.5/1.30	1500	30-100	0.8-2.2	20-120	1000	2500	Mo4-63-S
MF*600-**	600	1200-2000	55	1.5/1.30	1800	30-100	0.8-2.2	20-120	1000	2500	Mo4-66-S
MF*800-**	800	1200-2000	65	1.5/1.30	2400	30-100	0.8-2.2	20-120	1000	2500	Mo4-76-S
备注: *代表连接方式 **代表模块电压											



Mo2-20

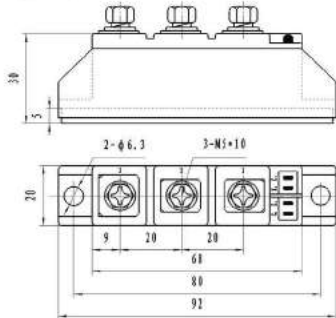

Mo2-34

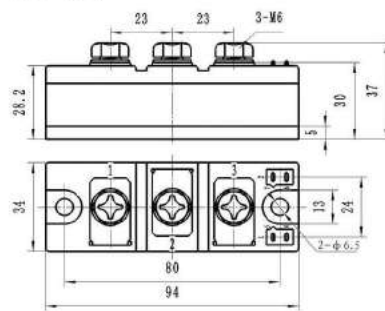

Mo2-36

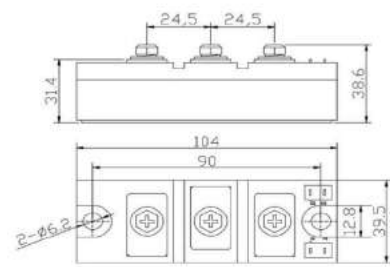

Mo4-50

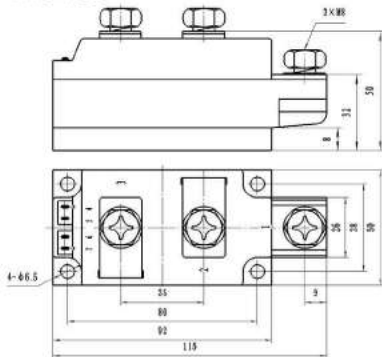

Mo4-53

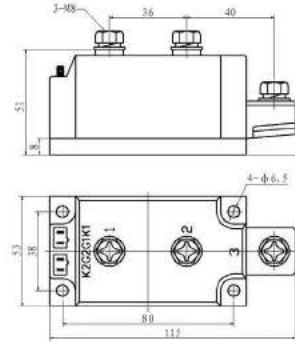

Mo4-53-S

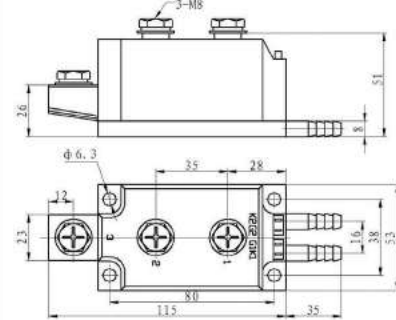

Mo4-60

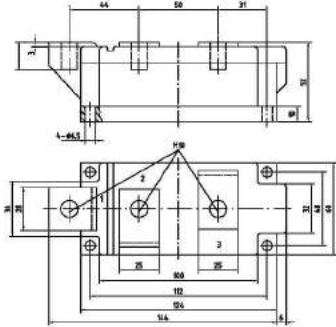

Mo4-63

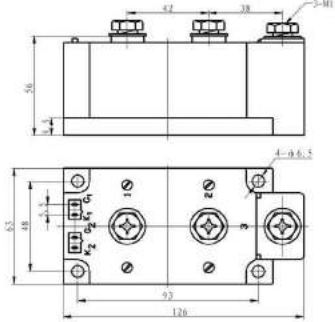

Mo4-63-S

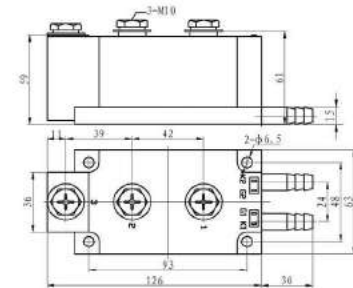

Mo4-66

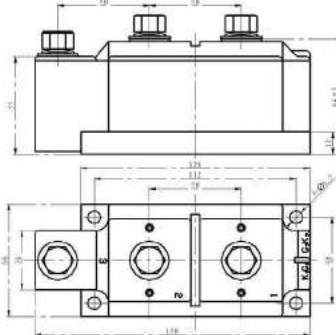

Mo4-66-S

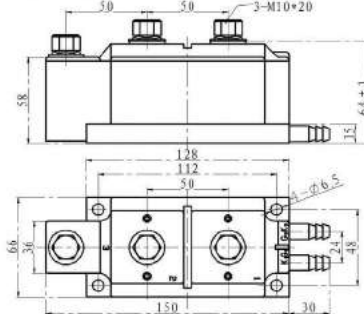

Mo4-76

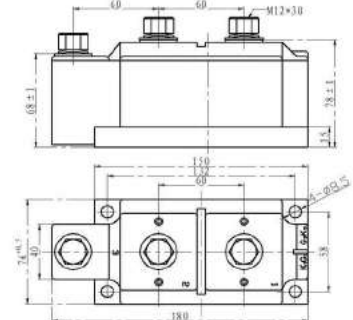

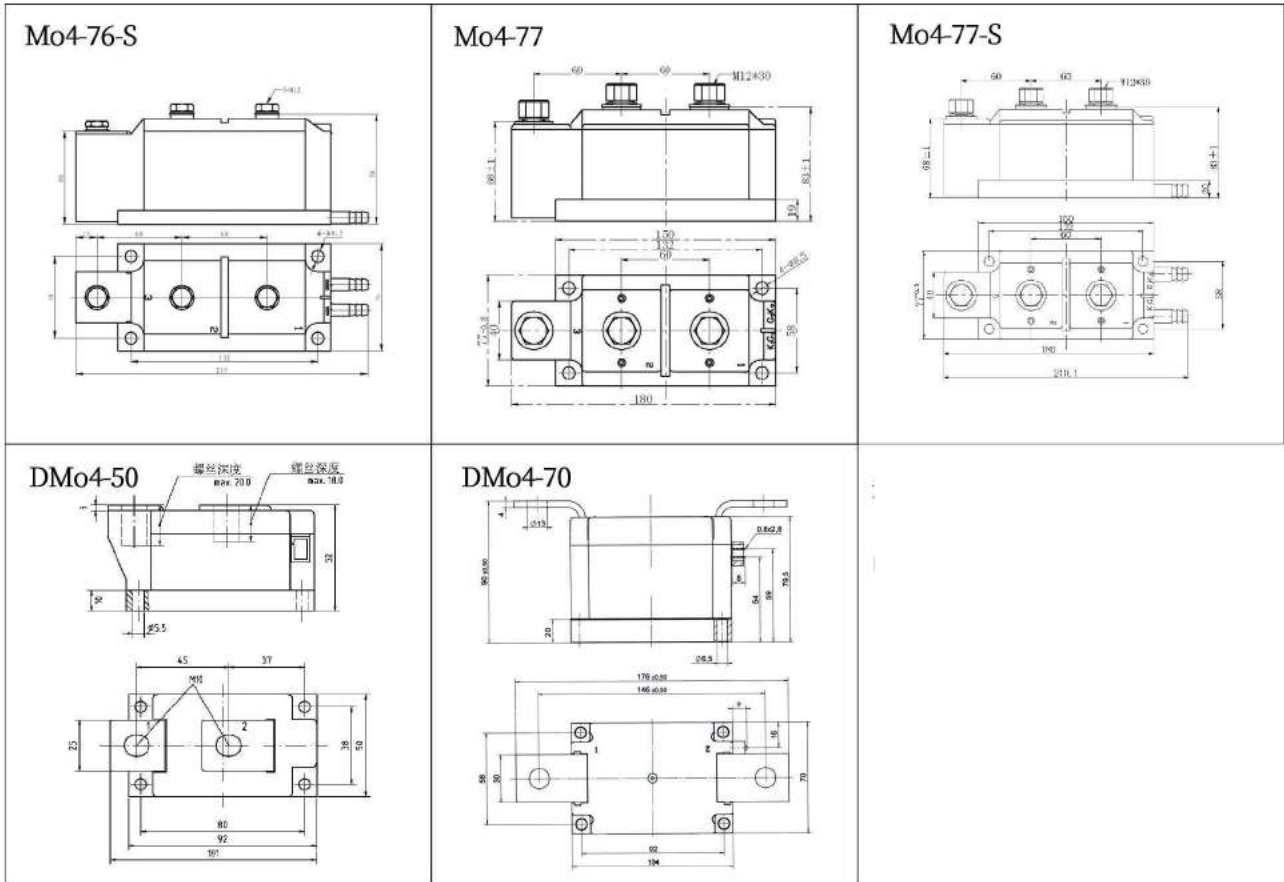

注：· 门极阴极引线长 300mm · 未标注数量单位的统一为毫米

Remark: · The standard length of gate and cathode leads is 300mm · All dimensions shown in mm unless stated otherwise

» 典型电路电联结方式 | Typical Electrical Connection Mod

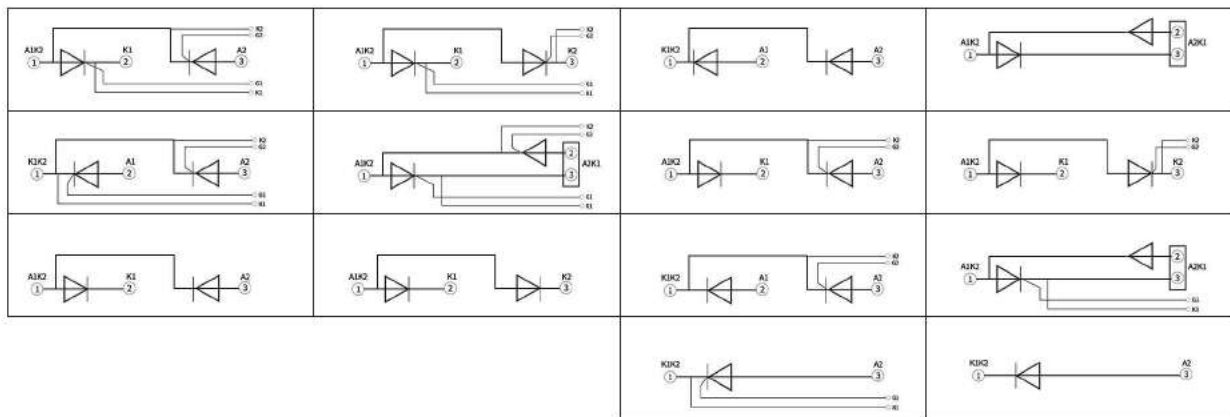

4

三相电力调整器
SCR Power Regulator



特点

- 结构新颖, 高品质
- 自体具有超温保护功能
- 最大输出量、最小输出量可调节

Features:

- Novel structure, high quality
- With over temperature protective function
- Adjustable for maximum and minimum output

规格

型号 Type		ALLSCR				
额定电流 Rated Current		30A	55A	90A	110A	160A
外型尺寸 Dimension (mm)	图	F1				
	W	215				
	L	155				
	H	185				
安装尺寸(mm) Installation Dimension	图	F2				
	W					
	L					



性能

- 额定电压: 三相380VAC(三相三线)
- 额定电流: 30A, 55A, 90A, 110A, 160A
- 使用频率: 50Hz/60Hz
- 输出方式: 相位输出
- 控制信号: 4-20mA, 0-5VDC, 0-10VDC
- 保护功能: 自体超温保护
- 使用环境: 温度45°C以下, 湿度90%CRH以下

Features:

- Rated voltage: Three-phase 380VAC (three-phase three-wire)
- Rated Current: 30A, 55A, 90A, 110A, 160A
- Operation Frequency: 50Hz/60Hz
- Output mode: phase output
- Control signal: 4-20mA, 0-5VDC, 0-10VDC
- Protective function: Auto-protection for over temperature
- Ambient temperature: Less than 45, humidity less than 90%RH

注意事项

- 主电路中采用三相三线输入, 无相序要求
- SCR为大电流产品, 请务必锁紧(R.S.T)及(U.V.W)端子, 否则会造成端子发热而导致SCR烧坏
- 负载Y型接法时中心点不能接零线, 否则会造成SCR失去控制
- 当散热器温度超过75°C时, 模块会自动保护停止工作, 此时只有电源指示LED灯亮

Warning:

- The main circuit adopts three-phase three-wire input without requirement for phase sequence.
- SCR is a product with big current, please keep in mind that terminals (R.S.T) and (U.V.W) shall not be locked tightly, or SCR burned by terminal heating.
- When Y connection is used for three-phase load, the center of Y should be connected with zero line, if not so, relative equilibrium of the three-phase is required.
- When the temperature of radiator exceeds 75°C:, the module will stop working automatically, and only the power indicating light is bright on the moment.

特点

- 结构新颖, 高品质
- 自体具有超温保护功能
- 线性移相控制电路, 稳定性好
- 精度高, 控温准确

Features:

- Novel structure, high quality
- With over temperature protective function
- Linear phase-shift control circuit, with good stability performance.
- High precision, Correct Temperature Contro.

规格

型号 Type		DXSCR
额定电流Rated Current		200A/300A/400A/500A/600A/800A
外型尺寸 Dimension (mm)	图	F1
	W	365
	L	250
	H	245
安装尺寸(mm) Installation Dimension	图	F2
	W	
	L	



性能

- 额定电压: 三相380VAC(三相三线)
- 额定电流: 300A, 400A, 500A, 600A
- 使用频率: 50Hz/60Hz
- 输出方式: 相位输出
- 控制信号: 4-20mA, 0-5VDC, 0-10VDC
- 保护功能: 快速熔断器
- 使用环境: 温度45°C以下, 湿度90%CRH以下

Features:

- Rated voltage: Three-phase 380VAC (three-phase three-wire)
- Rated Current: 300A, 400A, 500A, 600A
- Operation Frequency: 50Hz/60Hz
- Output mode: phase output
- Control signal: 4-20mA, 0-5VDC, 0-10VDC
- Protective function: Fast fuse
- Ambient temperature: Less than 45, humidity less than 90%RH

注意事项

- 主电路中采用三相三线输入, 无相序要求
- SCR为大电流产品, 请务必锁紧(R.S.T)及(U.V.W)端子, 否则会造成端子发热而导致SCR烧坏
- 模块保护: 负载过流保护请使用半导体快速熔断器
- 负载Y型接法时中心点不能接零线, 否则会造成SCR失去控制

Warning:

- The main circuit adopts three-phase three-wire input without requirement for phase sequence.
- SCR is a product with big current, please keep in mind that terminals (R.S.T) and (U.V.W) shall not be locked tightly, or SCR burned by terminal heating.
- Module protection: Please use semi-conductive fast fuse for load over current.
- When Y connection is used for three-phase load, the center of Y should be connected with zero line, if not so, relative rium of the three-phase is required.

特点

- 结构新颖, 高品质
- 自体具有超温保护功能
- 线性移相控制电路, 稳定性好
- 精度高, 控温准确

Features:

- Novel structure, high quality
- With over temperature protective function
- Linear phase-shift control circuit, with good stability performance.
- High precision, Correct Temperature Contro.

规格

型号 Type		DXSCR
额定电流Rated Current		200A/300A/400A/500A/600A/800A
外型尺寸 Dimension (mm)	图	F1
	W	365
	L	250
	H	245
安装尺寸(mm) Installation Dimension	图	F2
	W	
	L	



性能

- 额定电压: 三相380VAC(三相三线)
- 额定电流: 300A, 400A, 500A, 600A
- 使用频率: 50Hz/60Hz
- 输出方式: 相位输出
- 控制信号: 4-20mA, 0-5VDC, 0-10VDC
- 保护功能: 快速熔断器
- 使用环境: 温度45°C以下, 湿度90%CRH以下

Features:

- Rated voltage: Three-phase 380VAC (three-phase three-wire)
- Rated Current: 300A, 400A, 500A, 600A
- Operation Frequency: 50Hz/60Hz
- Output mode: phase output
- Control signal: 4-20mA, 0-5VDC, 0-10VDC
- Protective function: Fast fuse
- Ambient temperature: Less than 45, humidity less than 90%RH

注意事项

- 主电路中采用三相三线输入, 无相序要求
- SCR为大电流产品, 请务必锁紧(R.S.T)及(U.V.W)端子, 否则会造成端子发热而导致SCR烧坏
- 模块保护: 负载过流保护请使用半导体快速熔断器
- 负载Y型接法时中心点不能接零线, 否则会造成SCR失去控制

Warning:

- The main circuit adopts three-phase three-wire input without requirement for phase sequence.
- SCR is a product with big current, please keep in mind that terminals (R.S.T) and (U.V.W) shall not be locked tightly, or SCR burned by terminal heating.
- Module protection: Please use semi-conductive fast fuse for load over current.
- When Y connection is used for three-phase load, the center of Y should be connected with zero line, if not so, relative rium of the three-phase is required.

电力调整温度控制柜

Electric adjustment temperature control cabinet



特点

- 结构新颖, 高品质
- 自体具有超温保护功能
- 线性移相控制电路, 稳定性好
- 精度高, 控温准确

Features:

- Novel structure, high quality
- With over temperature protective function
- Linear phase-shift control circuit, with good stability performance.
- High precision, Correct Temperature Contro.

规格

规格Specifications	数据Data
额定电流Rated Current	300A/400A/500A/600A
工作频率Operation Frequency	50Hz/60Hz
输出模块Output Module:	移相输出shift phase output
控制信号The signals of control	4-20mA,0-5VDC,0-10VDC
温度Temperature	<45°C below 45°C
湿度 Humidity	<90RH below 90%RH
外形尺寸Boundary dimension	



性能

- 额定电压: 三相380VAC(三相三线)
- 额定电流: 300A, 400A, 500A, 600A
- 使用频率: 50Hz/60Hz
- 输出方式: 移相输出
- 控制信号: 4-20mA, 0-5VDC, 0-10VDC
- 保护功能: 快速熔断器
- 使用环境: 温度45°C以下, 湿度90%CRH以下

Features:

- Rated voltage: Three-phase 380VAC (three-phase three-wire)
- Rated Current: 300A, 400A, 500A, 600A
- Operation Frequency: 50Hz/60Hz
- Output mode: shift phase output
- Control signal: 4-20mA, 0-5VDC, 0-10VDC
- Protective function: Fast fuse
- Ambient temperature: Less than 45, humidity less than 90%RH

注意事项

- 主电路中采用三相三线输入, 无相序要求
- SCR为大电流产品, 请务必锁紧(R.S.T)及(U.V.W)端子, 否则会造成端子发热而导致SCR烧坏
- 模块保护: 负载过流保护请使用半导体快速熔断器
- 负载Y型接法时中心点不能接零线, 否则会造成SCR失去控制

Warning:

- The main circuit adopts three-phase three-wire input without requirement for phase sequence.
- SCR is a product with big current, please keep in mind that terminals (R.S.T) and (U.V.W) shall not be locked tightly, or SCR burned by terminal heating.
- Module protection: Please use semi-conductive fast fuse for load over current.
- When Y connection is used for three-phase load, the center of Y should be connected with zero line, if not so, relative rium of the three-phase is required.

6

散热器
Radiator



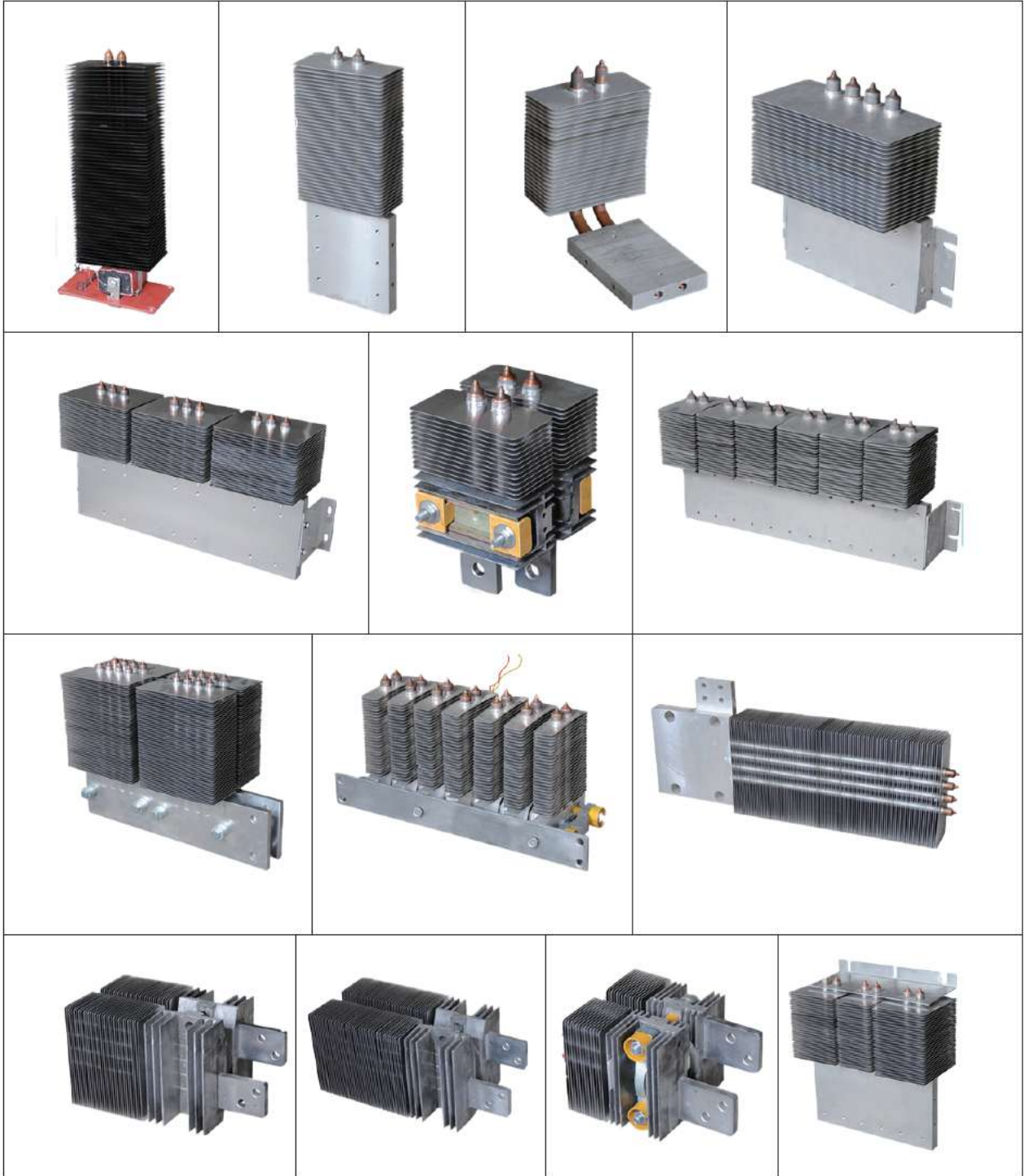

组件系列

Module Power Regulator

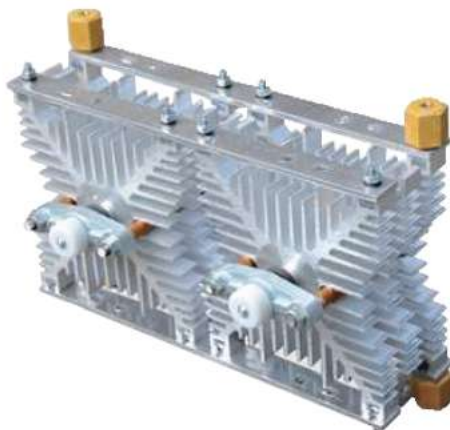



直接采用功率组件进行设备设计和制造,具有选型简单、可靠性高、综合成本低、安装使用方便、外形美观、开发速度快等一系列优点。目前在国际上较通用、并且已形成标准化的,以晶闸管和二极管为核心的组件品种有:

双反星形组件系列;

单相整流桥系列:包括单相全控、半控和整流桥;

三相全桥系列:包括三相全控整流、三相半控整流、三相整流桥;

六相桥系列:包括六相可控和不可控整流桥;

交流开关系列:包括单相和三相交流开关;

以及其他特殊电联结形式的产品。

从组件的冷却方式上看,有铝型材及热管的强迫风冷、自然冷却、水冷等不同的形式。从组件的功能上分,有具备基本电联结形式的功率组件;有在此基础上进一步配置阻容吸收、温度保护、通用或特殊控制功能的组件。我们公司可提供各种类型的晶闸管、二极管及其模块产品的功率组件,可广泛应用于整流、逆变、开关、控制等各种领域中。

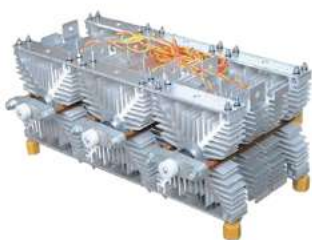

UTG630-1250A双反星形组件
长X宽X高:495X290X220



UTG630-1250A双反星形组件
长X宽X高:495X175X415

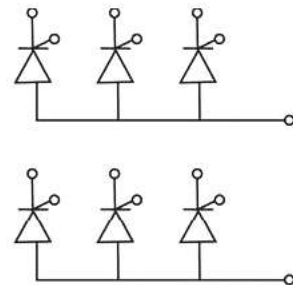

UTG630-1250A双反星形组件
长X宽X高:495X210X235



UTG630-1600A双反星形组件
长X宽X高:500X170X320

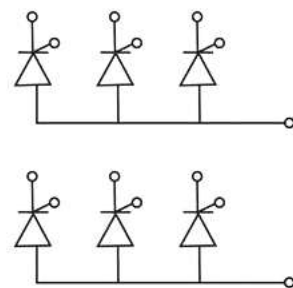



UTS300-1250A三相全控桥
长X宽X高: 495X175X220



UTS300-1500A三相全控桥
长X宽X高: 495X240X235

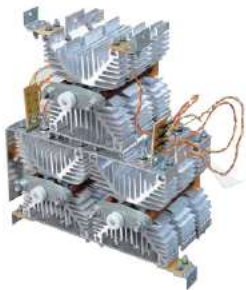
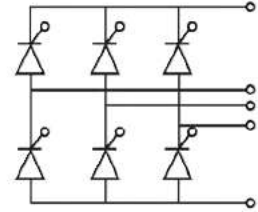

UTS630A-1250A三相全控桥
长X宽X高: 385X210X455



UTG630A-1250A三相全控桥
长X宽X高: 365X150X230

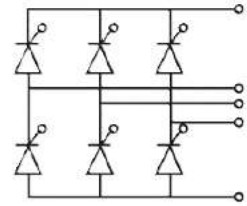

UFS630-1600A三相半控组件
长X宽X高: 430X300X150



UFS630-1600A三相半控组件
长X宽X高: 555X230X450

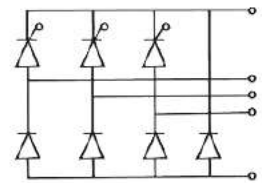

UTN630-1500A六相半波组件
长X宽X高: 465X160X280



UTN630-1500A六相半波组件
长X宽X高: 500X160X160

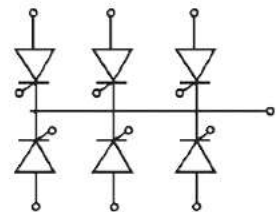

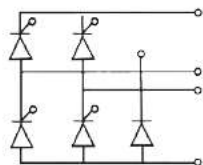

UTQ400-800A单向可控桥
长X宽X高: 410X250X325

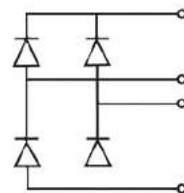

UDQ400-800A单向整流桥
长X宽X高: 325X140X242

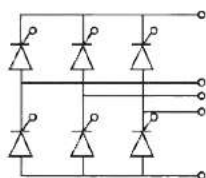
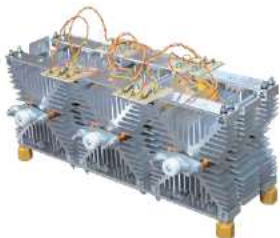

UTS630-1800A三相全控桥
长X宽X高: 495X235X235

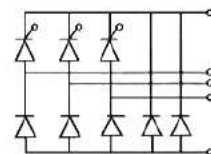

UFS630A-2000A三相半控组件
长X宽X高: 495X370X320



8

资质和证书

Qualifications and certificates





一种便于拆装的KP普通晶闸管



一种便于固定安装的模块组合



一种便于固定安装的桥臂模块



一种便于散热机构的整流管



一种便于调节的大功率水冷装置



一种便于线路连接的桥臂模块



一种多转接头的KP普通晶闸管



一种方便更换的快速晶闸管



一种防水型连接芯片



一种便于散热的双反星型组件



一种三相全控桥线路连接结构



一种循环散热的模块组合



一种组合模块间便捷卡锁合装置



高新技术企业