



STK8327

Digital Output 3-axis MEMS Accelerometer

Preliminary Datasheet

Version – 0.9.1

2020/12/01

Hazardous Substance Free

RoHS / REACH Compliant

Sensortek Technology Corporation

1. OVERVIEW

Description

The STK8327 is a $\pm 2g/\pm 4g/\pm 8g/\pm 16g$, 3-axis linear accelerometer, with digital output (I²C and SPI). It is a low-profile capacitive MEMS sensor featuring, compensation for 0g offset and gain errors, and conversion to 16-bit digital values at user configurable samples per second. The device can be arranged for sensor data changes through the interrupt pins. The STK8327 is available in a small 2.0mm x 2.0mm x 1.0 mm LGA package and it is guaranteed to operate over an extended temperature range from -40 °C to +85 °C.

Feature

- Low Voltage Operation:
 - Supply Internal Domain Voltage: 1.7V~3.6V
 - I/O Voltage Range: 1.62V~3.6V
- $\pm 2g/\pm 4g/\pm 8g/\pm 16g$ dynamically selectable full-scale
- I²C digital output interface
- 3-wire and 4-wire SPI digital output
- 2 physical interrupts
- Low noise
- 16-bit data output
- 10000 g high shock survivability
- 2.0mm x 2.0mm x 1.0 mm LGA Package
- Configurable Samples from 14 to 2000 samples per second
- Sleep Feature for Low Power Consumption
- On-chip interrupt controller, motion-triggered interrupt-signal generation for
 - New data
 - Any-motion (slope) detection
 - Significant motion
- On-chip FIFO, integrated 32 frames FIFO buffer
- RoHS Compliant
- Halogen Free
- Environmentally Preferred Product
- Moisture Sensitivity Level 3

Applications

- Display orientation
- Gaming and virtual reality input devices
- Impact recognition and logging
- Vibration monitoring and compensation
- Pedometer
- Activity trackers for fitness apps
- Smart power management for mobile devices

2. PIN DESCRIPTION

Pin#	Name	Dir.	Function
1	SA0/SDO	I	I ² C slave address selection pin, '1' for 0x1F and '0' for 0x0F. Serial Data Output (SPI 4-Wire)/ NC (SPI 3-Wire).
2	SDA/SDI/SDIO	B	Serial Data (I ² C, Open-Drain). Serial Data Input (SPI 4-Wire). Serial Data Input and Output (SPI 3-Wire).
3	VDDIO	PWR	Digital Interface Supply Voltage.
4	Reserved	I	Recommended tie to GND.
5	INT1	O	Interrupt 1 Output.
6	INT2	O	Interrupt 2 Output.
7	VS	PWR	Supply Voltage.
8	GNDIO	GND	Must be connected to ground.
9	GND	GND	Must be connected to ground.
10	/CS	I	'0' for SPI mode. '1' or floating for I ² C mode. SPI mode Chip Select.
11	NC	NC	Not Internally Connected.
12	SCL/SCK	I	Serial Communications Clock (I ² C, Open-Drain).

Direction denotation

O	Output	GND	Ground
I	Input	B	Bi-direction
PWR	Power	NC	Not Connected

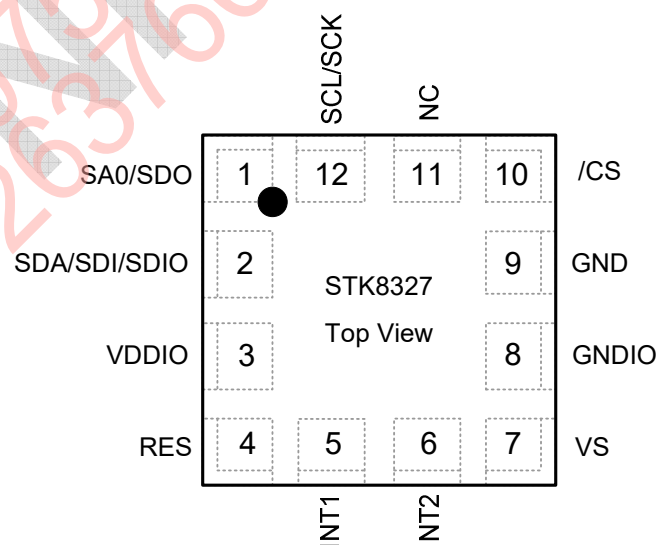

3. FUNCTION BLOCK

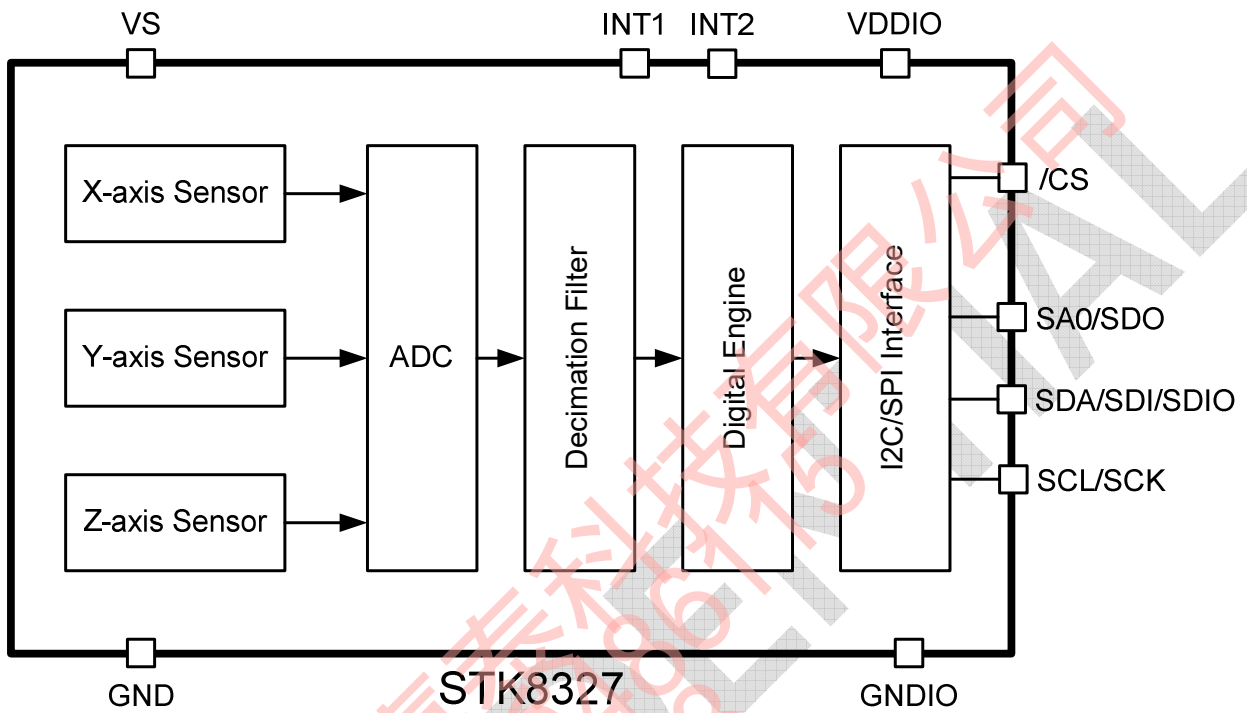

4. ELECTRICAL SPECIFICATIONS

$T_A = 25^\circ\text{C}$, $V_S = 2.6\text{ V}$, $V_{DDIO} = 2.6\text{ V}$, acceleration = 0 g, $C_S = C_{I/O} = 10\ \mu\text{F}$ and $0.1\ \mu\text{F}$

Parameter	Test Conditions	Min	Typ	Max	Unit
POWER SUPPLY					
Operating Voltage Range (VS)		1.7	1.8	3.6	V
Interface Voltage Range (VDDIO)		1.62	1.8	3.6	V
Current consumption in normal mode			110		μA
Current consumption in suspend mode			1		μA
Current consumption in low-power mode	Sleep duration=25 ms Bandwidth=1k Hz		7		μA
Digital high level input voltage (VIH)		0.7 x VDDIO			V
Digital low level input voltage (VIL)				0.3 x VDDIO	V
High level output voltage (VOH) ¹		0.8 x VDDIO			V
Low level output voltage (VOL) ¹				0.2 x VDDIO	V
OUTPUT DATA RATE AND BANDWIDTH		Each axis			
Bandwidth (BW)			7.81		Hz
			15.63		Hz
			31.25		Hz
			62.5		Hz
			125		Hz
			250		Hz
			500		Hz
			1000		Hz
Output data rate (ODR) in normal mode			BW * 2		Hz

1. $I_{OL} = 10\text{mA}$, $I_{OH} = -4\text{mA}$

5. MECHANICAL SPECIFICATIONS

$T_A = 25^\circ\text{C}$, $V_S = 2.6\text{ V}$, $V_{DDIO} = 2.6\text{ V}$, acceleration = 0 g, $C_S = C_{I/O} = 10\ \mu\text{F}$ and $0.1\ \mu\text{F}$

Parameter	Test Conditions	Min	Typical	Max	Unit
SENSOR INPUT	Each axis				
Measurement Range	User selectable		$\pm 2, \pm 4, \pm 8, \pm 16$		g
Non-linearity	Percentage of full scale		± 0.5		%FS
Cross-Axis Sensitivity			1		%
OUTPUT RESOLUTION	Each axis				
$\pm 2\text{ g}$ Range	Full resolution		16		Bits
$\pm 4\text{ g}$ Range	Full resolution		16		Bits
$\pm 8\text{ g}$ Range	Full resolution		16		Bits
$\pm 16\text{ g}$ Range	Full resolution		16		Bits
SENSITIVITY	Each axis				
Sensitivity at XOUT, YOUT, ZOUT	$\pm 2\text{g}$, 16-bit resolution		16384		LSB/g
	$\pm 4\text{g}$, 16-bit resolution		8192		LSB/g
	$\pm 8\text{g}$, 16-bit resolution		4096		LSB/g
	$\pm 16\text{g}$, 16-bit resolution		2048		LSB/g
Sensitivity Change Due to Temperature	X-, Y-, Z-Axes		± 0.02		%/ $^\circ\text{C}$
0 g OFFSET ¹	Each axis				
0 g Output for XOUT, YOUT, ZOUT			± 50		mg
0 g Offset Change Due to Temperature	X-, Y-, Z-Axes		± 1		mg/ $^\circ\text{C}$
NOISE					
X-, Y-, Z-Axes	$\pm 2\text{g}$, 16-bit resolution BW = 62.5 Hz		200		$\mu\text{g}/\sqrt{\text{Hz}}$

1. These parameters are tested in production at final test, and could slightly change after mounting the sensor onto a printed circuit board or exposing it to extensive mechanical stress.

6. ABSOLUTE MAXIMUM RATINGS

Symbol	Ratings	Maximum value	Unit
VS	Supply voltage	-0.3 to 3.6	V
VDDIO	Digital Interface Supply Voltage	-0.3 to 3.6	V
Vin	Input voltage on any control pin	-0.3 to 3.6	V
A _{UNP}	Acceleration (any axis, unpowered)	10000	g
T _{OP}	Operating temperature range	-40 to +85	°C
T _{STG}	Storage temperature range	-40 to +125	°C
ESD	Electrostatic discharge protection	2 (HBM)	kV
		500 (CDM)	V
		200 (MM)	V
		100 (Latch Up)	mA

7. DIGITAL INTERFACE

Both I²C and SPI digital interface are available in STK8327. In both cases, the STK8327 operates as a slave device. /CS (chip select) pin state is used to select the operation interface. The I²C mode is enabled if the /CS pin is tied high to VDDIO. And the SPI mode is enabled when the /CS pin is tied to low.

7.1 I²C

All registers in STK8327 can be accessed via the I²C bus. All operations can be controlled by the related registers. There are two signals associated with the I²C bus: the serial clock line (SCL) and the serial data line (SDA). The latter is a bidirectional signal used for sending and receiving the data to/from the interface. Both signals are pull-up to V_{DD I/O} through an external resistor.

The Slave Address associated to the STK8327 is 0x0F or 0x1F which is modified by the ADDSEL pin. If the ADDSEL pin is connected to the VDDIO, the address is 0x1F, otherwise if the ADDSEL pin is connected to ground, the address is 0x0F. This solution permits to connect and address two different accelerometers to the same I²C lines.

A watchdog timer (WDT) is used to prevent the I²C bus lock-up by STK8327. The I²C bus will be reset and return to normal operation state once the WDT is reached. The WDT can be enabled/disabled by I2C_WDT_EN bit and the timer period can be set by I2C_WDT_SEL bit in register [INTFCFG](#)(0x34)

The STK8327 I²C command format description for reading and writing operation between the host and STK8327 are shown in the following timing chart.

Slave Address

/CS pin	SA0 pin	Slave Address (7-bit)	R/W Command Bit	OPERATION
1 or float	1	0x1F	0	Write Data to STK8327
			1	Read Data form STK8327
	0	0x0F	0	Write Data to STK8327
			1	Read Data form STK8327

Characteristics of the I²C Timing

Symbol	Parameter	Standard Mode		Fast Mode		Unit
		Min.	Max.	Min.	Max.	
f _{SCLK}	SCL clock frequency	10	100	10	400	kHz
t _{HDSTA}	Hold time after (repeated) start condition. After this period, the first clock is generated	4.0	—	0.6	—	μs
t _{LOW}	LOW period of the SCL clock	4.7	—	1.3	—	μs
t _{HIGH}	HIGH period of the SCL clock	4.0	—	0.6	—	μs
t _{SUSTA}	Set-up time for a repeated START condition	4.7	—	0.6	—	μs
t _{HDDAT}	Data hold time	0	—	0	—	ns
t _{SUDAT}	Data set-up time	250	—	100	—	ns
t _r	Rise time of both SDA and SCL signals	—	1000	—	300	ns
t _f	Fall time of both SDA and SCL signals	—	300	—	300	ns
t _{SUSTO}	Set-up time for STOP condition	4.0	—	0.6	—	μs
t _{BUF}	Bus free time between a STOP and START condition	4.7	—	1.3	—	μs

Note: f_{SCLK} is the (t_{SCLK})⁻¹.

Timing Chart of the I²C

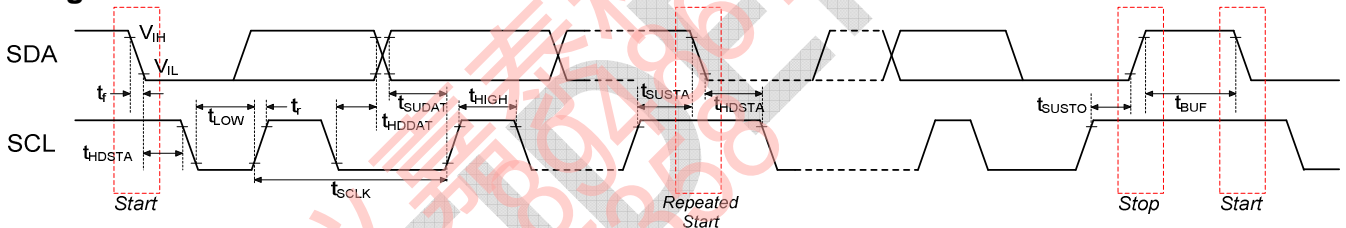

I²C Write Command

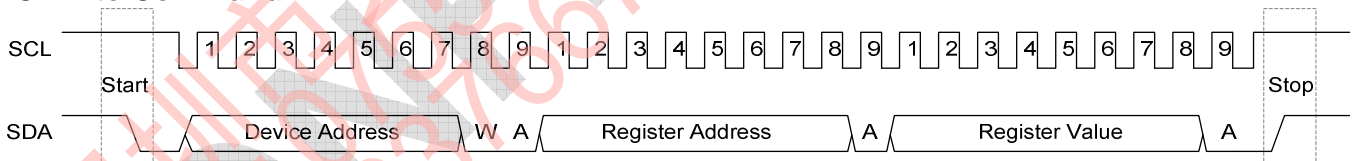

I²C Read Data

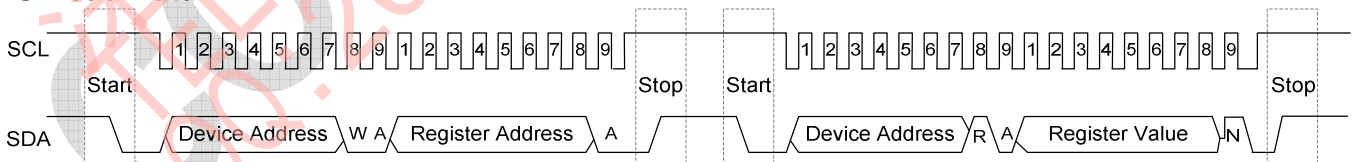

I²C Sequential Read Data

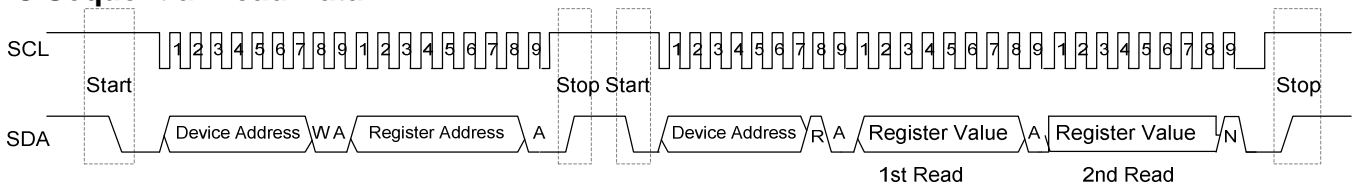

7.2 SPI

For SPI, either 3- or 4-wire configuration is possible. The STK8327 is also compatible with '00' (mode 0) and '11' (mode 3) SPI mode. The automatic selection between '00' [CPOL = 0 and CPHA = 0] and '11' [CPOL = 1 and CPHA = 1] is done based on the SCK value at the falling edge of /CS.

The 3- or 4-wire SPI connection diagram are shown below. The maximum SPI clock speed is 8MHz with 25pF maximum loading. The 3-wire SPI can be selected by setting SPI_3WM bit in [INTFCFG](#) (0x34) to 1. When using 3-wire SPI, it is recommended that the SDO pin either be pulled up to VDDIO or be pulled down to GND via a 10 kΩ resistor.

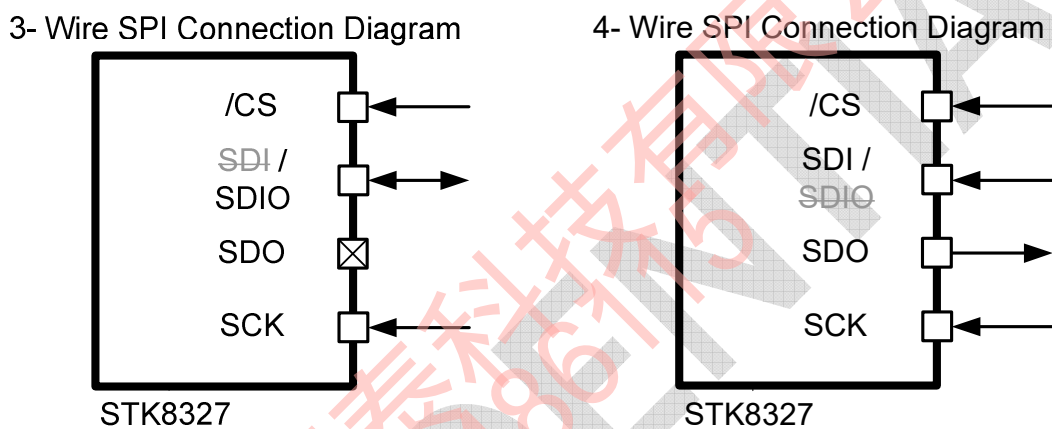

The timing diagram for 3-wire and 4-wire SPI reads or writes is shown in the following figure.

Characteristics of the SPI Timing

Symbol	Parameter	Condition	Min.	Max.	Unit
f _{SCLK}	SPI clock frequency.			8	MHz
t _{SCLK}	1/ f _{SCLK}		12.5	—	ns
t _{HIGH}	SCLK high pulse width.		6.25		ns
t _{LOW}	SCLK low pulse width.		6.25		ns
t _{DELAY}	/CS falling edge to SCLK falling edge.		30	—	ns
t _{QUITE}	SCLK rising edge to /CS rising edge		70	—	ns
t _{SETUP}	Set-up time for SDI		20	—	ns
t _{HOLD}	Hold time for SDI		20	—	ns
t _{SDO}	SDO output delay.	VDDIO > 2.2V	—	30	ns
		VDDIO ≤ 2.2V	—	40	ns
t _{IDLE}	SPI bus idle time between two success bus transactions.		20	—	ns