

LOW VOLTAGE VIDEO AMPLIFIER WITH LPF

■GENERAL DESCRIPTION

The **NJM2561A** is a low voltage single video amplifier with low pass filter.

The **NJM2561A** features low power and small package. It is suitable for any video application.

■PACKAGE OUTLINE



NJM2561AKG1

■FEATURES

- Operating Voltage 2.6 to 5.5V
- 6th Order LPF -33dB at 19MHz typ.
- 6dB Amplifier
- 75Ω Driver Circuit
- Power Save Circuit
- Bipolar Technology
- Package Outline ESON6 (1.6 x 1.6 x 0.4 mm)

■PIN CONFIGURATION

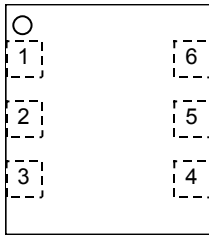

1. Vsag
2. GND
3. Power Save
4. V+
5. Vout
6. Vin

■BLOCK DIAGRAM

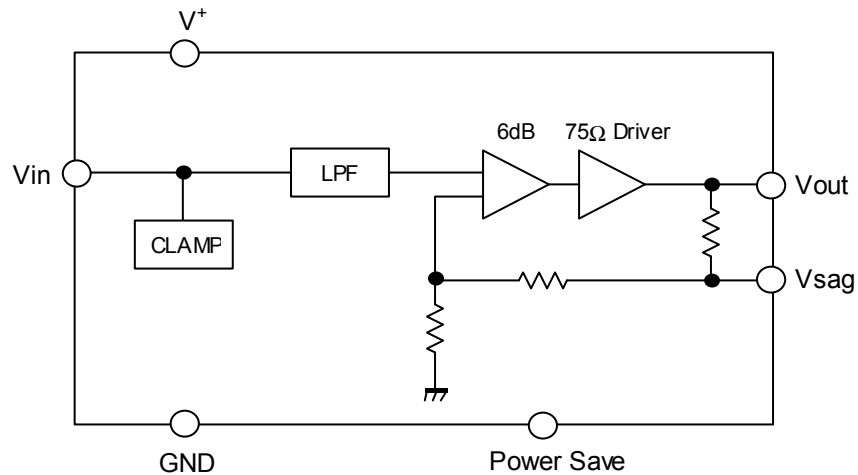

NJM2561A

■ABSOLUTE MAXIMUM RATINGS (Ta=25°C)

PARAMETER	SYMBOL	RATINGS	UNIT
Supply Voltage	V ⁺	7.0	V
Power Dissipation	P _D	260 (Note1) 950(Note2)	mW
Operating Temperature Range	Topr	-40 to +85	°C
Storage Temperature Range	Tstg	-40 to +125	°C

(Note1) Mounted on glass epoxy board based on EIA/JEDEC STANDARD. (101.5×114.5×1.6mm: 2Layers FR-4)

(Note2) Mounted on glass epoxy board based on EIA/JEDEC STANDARD.

(101.5×114.5×1.6mm: 4Layers FR-4, Internal foil area size: 99.5×99.5mm, Applying a thermal via hole to a board based on JEDEC standard JESD51-5)

■ RECOMMENDED OPERATING CONDITION (Ta=25°C)

PARAMETER	SYMBOL	TEST CONDITION	MIN.	TYP.	MAX.	UNIT
Operating Voltage	Vopr		2.6	3.0	5.5	V

■ELECTRICAL CHARACTERISTICS (V⁺=3.0V, R_L=150Ω, Ta=25°C)

PARAMETER	SYMBOL	TEST CONDITION	MIN.	TYP.	MAX.	UNIT
Operating Current	I _{CC}	No Signal	-	8.0	12.0	mA
Operating Current at Power Save	I _{save}	No Signal, Power Save Mode	-	30	50	μA
Maximum Output Voltage Swing	V _{om}	f=100kHz, Sine Signal, THD=1%	2.2	2.5	-	Vp-p
Voltage Gain	G _v	V _{in} =100kHz, 1.0Vp-p, Sine Signal	6.1	6.5	6.9	dB
Low Pass Filter Characteristic	G _{fy} 4.5M	V _{in} =4.5MHz/100kHz, 1.0Vp-p	-0.6	-0.1	0.4	dB
	G _{fy} 19M	V _{in} =19MHz/100kHz, 1.0Vp-p	-	-33	-23	
Differential Gain	DG	V _{in} =1.0Vp-p, 10step Video Signal	-	0.5	-	%
Differential Phase	DP	V _{in} =1.0Vp-p, 10step Video Signal	-	0.5	-	deg
S/N Ratio	SN _v	V _{in} =1.0Vp-p, R _L =75Ω 100% White Video Signal, f= 100kHz to 6MHz	-	65	-	dB
2nd. Distortion	H _v	V _{in} =1.0Vp-p, 3.58MHz, Sine Signal, R _L =75Ω	-	-50	-	dB
SW Change Voltage High Level	V _{thPH}	Active	1.8	-	V ⁺	V
SW Change Voltage Low Level	V _{thPL}	Non-active	0	-	0.3	

■CONTROL TERMINAL

PARAMETER	STATUS	NOTE
Power Save	H	Power Save: OFF(Active)
	L	Power Save: ON (Mute)
	OPEN	Power Save: ON (Mute)

■TEST CIRCUIT

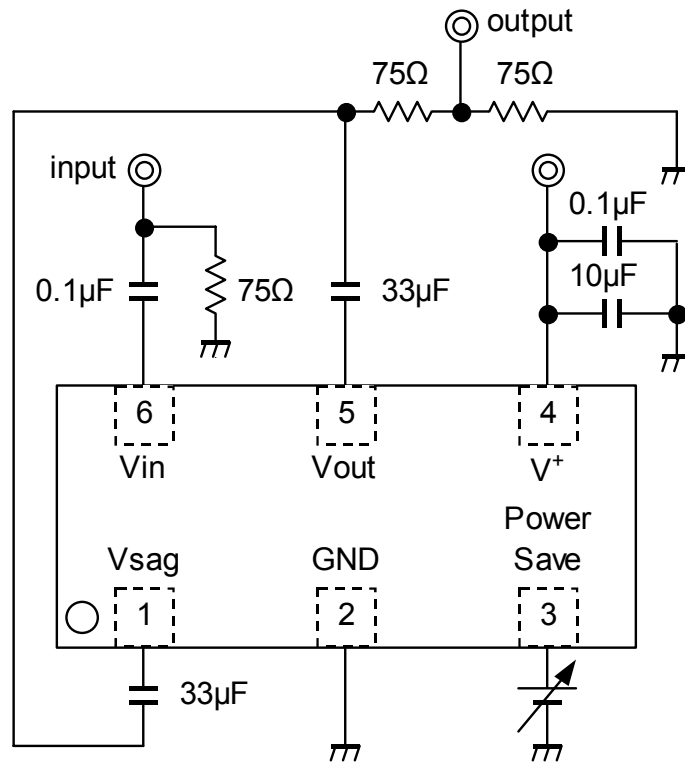

NJM2561A

APPLICATION CIRCUIT

(1) Standard circuit

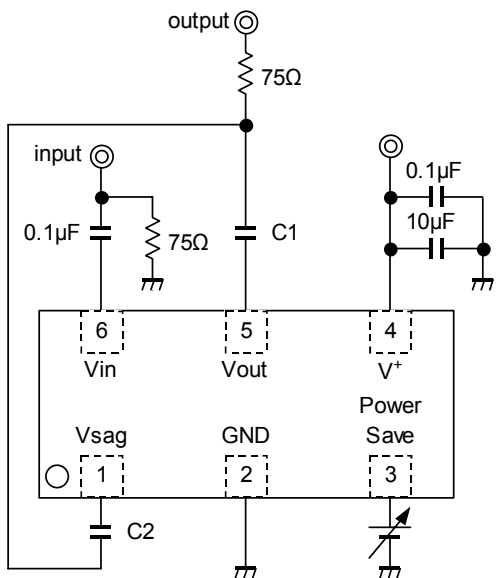

(2) SAG correction unused circuit

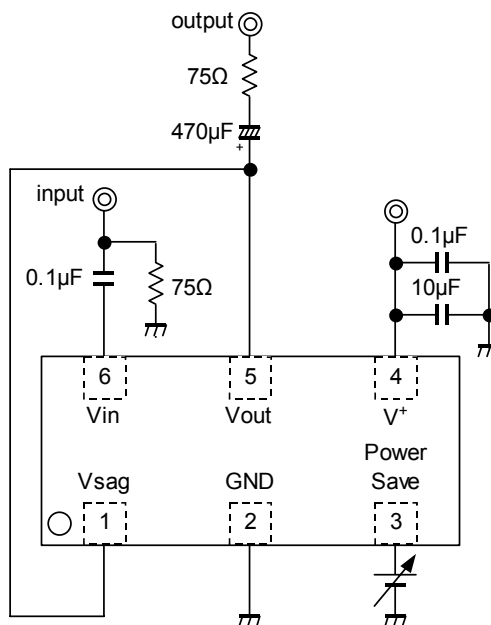

(3) Two-line driving circuit

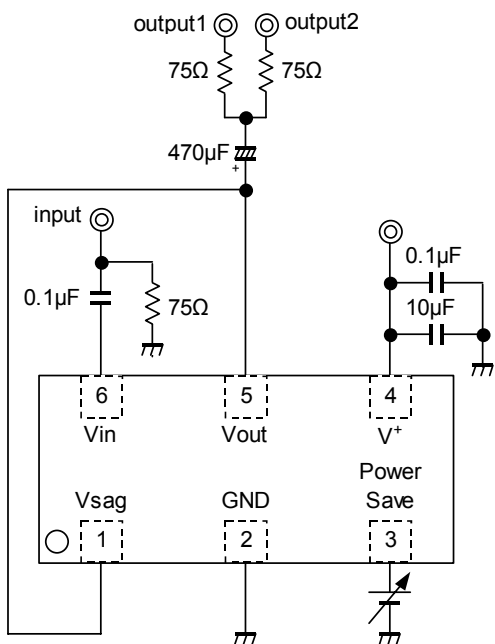

(1) Standard circuit

This circuit is for a portable equipment of small mounting space.

The SAG correction reduces output coupling capacitor values.

However, this circuit may cause to SAG deterioration, and lose synchronization by luminance fluctuation.

Adjust the C1 value, checking the waveform containing a lot of low frequency components like a bounce waveform (Worst condition waveform of SAG). Change the capacitor of C1 into a large value to improve SAG.

(2) SAG correction unused circuit

We recommend this circuit when there is no space limitation.

Connect the coupling capacitor after connecting the Vout pin and Vsag pin. The recommended value is 470µF or more.

(3) Two-line driving circuit

This circuit drives two-line of 150Ω. However, it may cause to lose synchronization by an input signal of large APL change (100% white signals more than 1Vp-p). Confirm the large APL change waveform (100% white signals more than 1Vp-p) and evaluate sufficiently.

INSTRUCTIONS AND DIRECTIONS FOR USE

(1) Standard circuit

The SAG correction circuit reduces output coupling capacitor values. However, this circuit may cause to SAG deterioration, and lose synchronization by luminance fluctuation. Checking the waveform containing a lot of low frequency components like a bounce waveform (Worst condition waveform of SAG). Refer to Figure 1 and Figure 2.

(2) SAG correction unused circuit

To stabilize the synchronized signal, we recommend this circuit. Connect the coupling capacitor after connecting the Vout pin and Vsag pin. The recommended value is 470 μ F or more. Refer to Figure 3 and Figure 4.

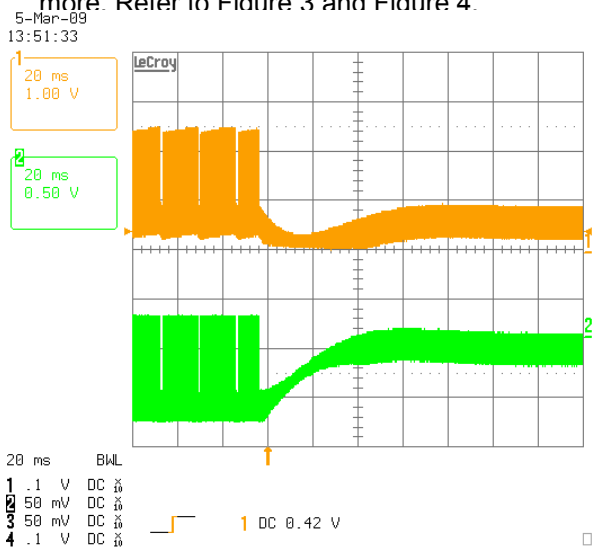

Figure 1

C1: 100 μ F, C2: 22 μ F
 Input Signal: 1Vp-p, White \rightarrow Black Waveform
 Orange: Vout Pin Waveform
 Green: waveform after output capacitor

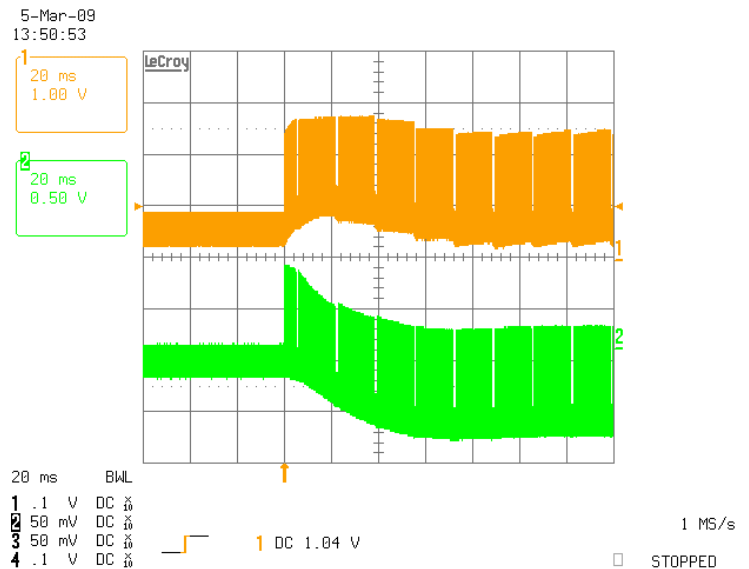

Figure 2

C1: 100 μ F, C2: 22 μ F
 Input Signal: 1Vp-p, Black \rightarrow White Waveform
 Orange: Vout Pin Waveform
 Green: waveform after output capacitor

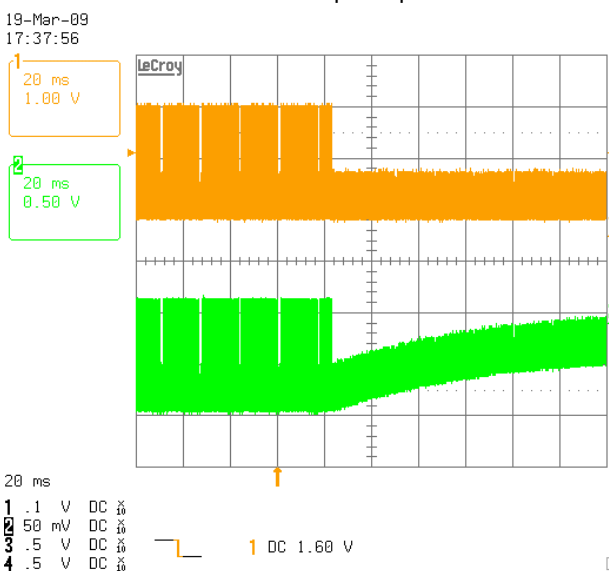

Figure 3

Output coupling capacitor: 470 μ F
 Input Signal: 1Vp-p, White \rightarrow Black Waveform
 Orange: Vout Pin Waveform
 Green: waveform after output capacitor

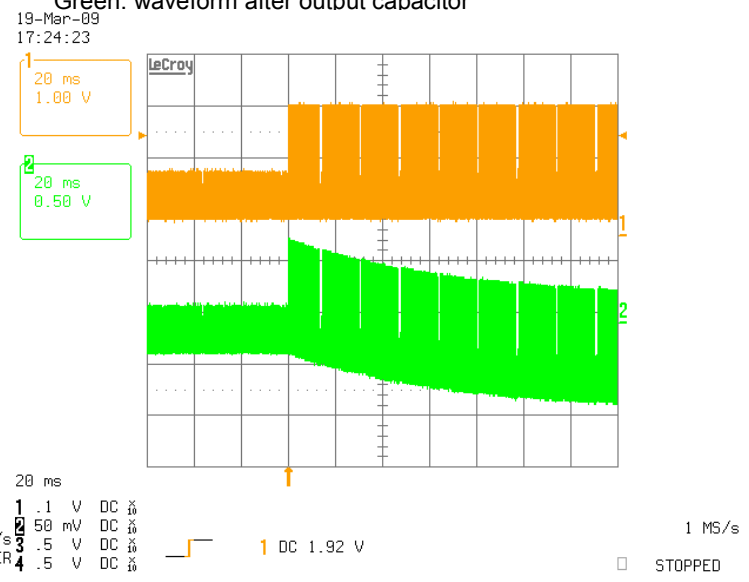

Figure 4

Output coupling capacitor: 470 μ F
 Input Signal: 1Vp-p, Black \rightarrow White Waveform
 Orange: Vout Pin Waveform
 Green: waveform after output capacitor

[CAUTION]

The specifications on this databook are only given for information, without any guarantee as regards either mistakes or omissions. The application circuits in this databook are described only to show representative usages of the product and not intended for the guarantee or permission of any right including the industrial rights.