

Text color(印字顏色) : 59.5x5.0mm區域底色為PANTONG109C(黃色)

U V W 為縷空字

Font(字體) : Arial

Text high(字高) : 4.0mm,字體線條寬度: 0.50mm ▲

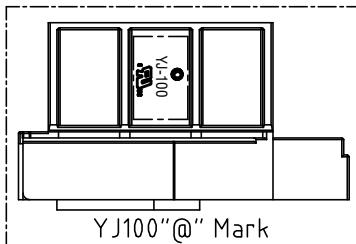
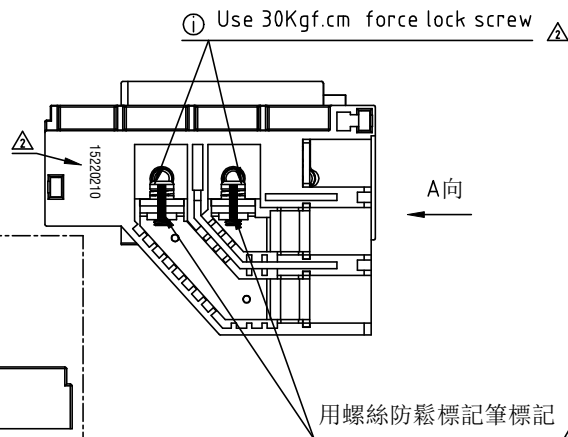
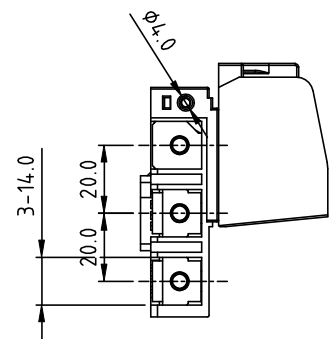
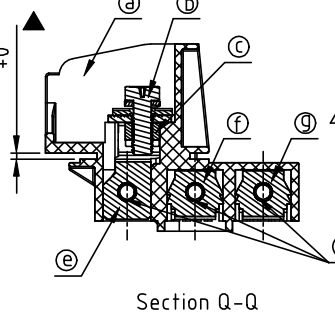
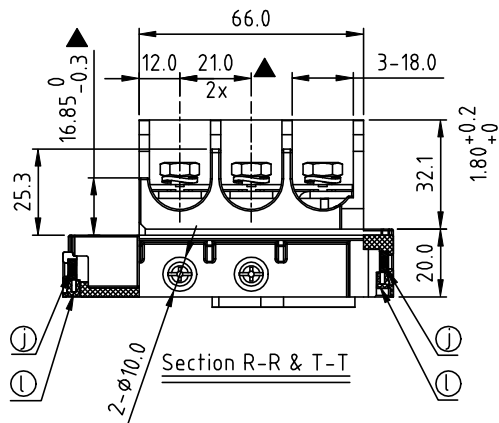
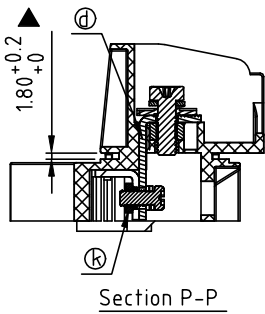
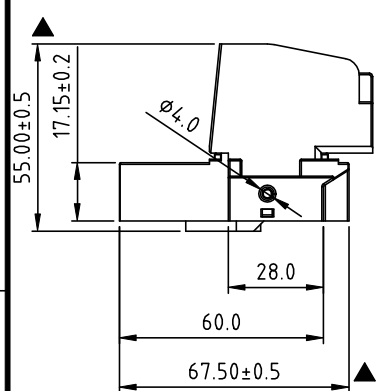
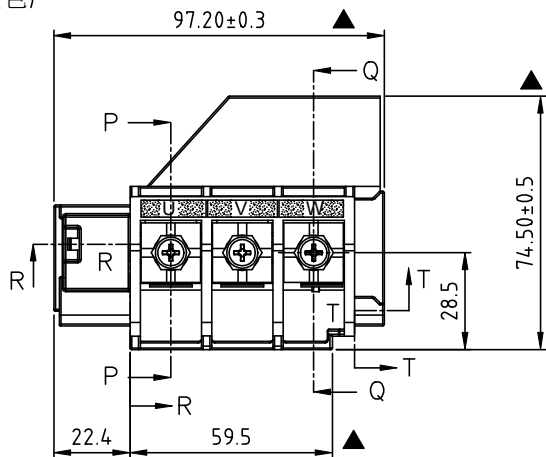
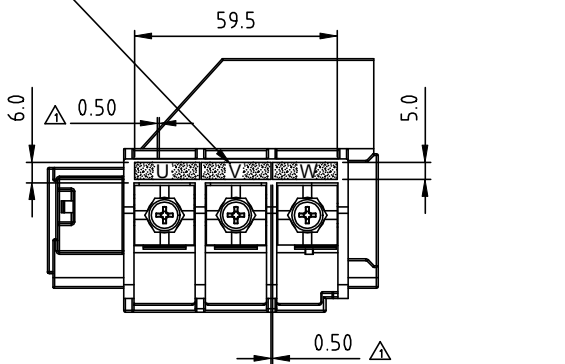

REV	SIGN	DATE	DESCRIPTION	APPROVER
B		03/31`17	Initial release	Chen Bo
C	▲	10/11`17	Change the print and add the note	Chen Bo
	▲	11/23`17	Add the torque force	Chen Bo
D	▲	04/04`18	Change the plating specification	Chen Bo

THIS IS CAD DRAWING, DO NOT REVISE MANUALLY!!!

Material:

- Item ㉑ Terminal housing: PBT (UL94V-0)
- Item ㉒ Terminal screws with washer: Steel, Ni plating, M5.0
- Item ㉓ Terminal nut: Steel, Zinc plating, M5.0
- ▲ Item ㉔ Female contact -01: Brass, Ni plating
- ▲ Item ㉕ Female contact -02: Brass, Ni plating
- ▲ Item ㉖ Female contact -03: Brass, Ni plating
- ▲ Item ㉗ Female contact -04: Brass, Ni plating
- Item ㉘ Terminal nut: Steel, Zinc plating, M5.0
- Item ㉙ Terminal screws with washer: Steel, Ni plating, M5.0
- ▲ Item ㉚ Terminal nut: Steel, Zinc plating, M3.0 12Kgf.cm
- Item ㉛ Terminal nut: Steel, Zinc plating, M5.0
- Item ㉜ Terminal cover: PBT (UL94V-0)

Electrical:

- Voltage rating: 600 V
- Current rating: 74 A
- Screw: M5
- ▲ Item ㉝ Screw Torque : 45Kgf.cm
- Applicable wire(AWG): 8`1/0
- Withstanding Voltage: 2.2 KV
- Operating temperature: -40°C to +115°C
- Safety Approval: cULus
- Critical dimension: ▲

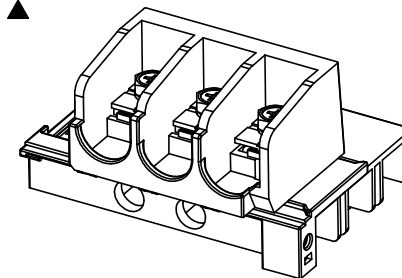

Amphenol
ANYTEK

CUSTOMER COPY

ALL RIGHTS RESERVED. REPRODUCTION OR ISSUE TO THIRD PARTIES IN ANY FORM WHATSOEVER IS NOT PERMITTED WITHOUT WRITTEN AUTHORITY FROM THE PROPRIETOR. PROPERTY OF ANYTEK TECHNOLOGY CO., LTD

TITLE		YJ-100 Power terminal (74A)Print: U V W			DWG NO.		8YJ0001-100		
PART NO.		YJ10003100HCG			APPROVED		CHECKED		
		Chen Bo		Chen Bo				Tolerance	
		04/04-18		02/24`16				X. ±0.50	
								X.X ±0.30	
								X.XX ±0.10	
								X° ±1°	
SHEET: 01/01		UNIT: mm		SCALE: NONE		REV.: D			